

makers
for life

 **Steel-Line**
garage doors



RD800

Roller Door Opener Installation and Operating Instructions



THIS MANUAL CONTAINS IMPORTANT SAFETY INFORMATION
DO NOT PROCEED WITH THE INSTALLATION BEFORE READING THIS MANUAL THOROUGHLY



Contents

User Information.....	1	Safety Reverse Test.....	8
Important Safety Instructions.....	2	Safety Reversal Force Adjustment.....	9
Package Contents.....	3	Reset Opener.....	9
Tools Required.....	3	Warning Labels.....	9
Door Requirements.....	3	Coding Wireless Transmitters.....	10
Testing the Door.....	4	Safety Beam Installation.....	11
Installing the Weight Bar.....	4	Auto-Close Timer.....	11
Installation Instructions.....	4-5	Maintenance Reminder.....	12
Using the Manual Release.....	5	Technical Specifications.....	13
Control Panel.....	6	Troubleshooting.....	14
Setting Direction of Operation.....	7	Warranty.....	15
Setting Travel Limits.....	8		

User Information

Important Safety Notes:

A garage door is the largest automated moving object in most homes. Care needs to be taken when using this system.

Like any other electrical appliance or machine, it is important to familiarise yourself with the safety guidelines which are applicable to automated garage doors. These are contained at the beginning and throughout this booklet.

The following summary highlights some of these safety guidelines:

- ✓ Only operate the garage door when in full view to ensure people, objects and pets remain away from the door whilst it is moving.
- ✓ Keep all controls away from children and do not allow them to play with the door.
- ✓ Regularly check the door and have it maintained and serviced as per the manufacturers' instructions.
- ✓ Safety beams or an equivalent safety device are recommended for any automated door for additional safety.

Standard Operation of the Door:

If the door is OPENING: When the programmed remote control (transmitter) button is pressed, it will stop the door. The next press will start the door moving in the opposite direction.

If the door is CLOSING: When the programmed remote control (transmitter) button is pressed, it will immediately start opening door.

Installation Details:

Installation Date:	
Installed by:	
Telephone Number:	

PLEASE RETAIN YOUR RECEIPT FOR WARRANTY PUPOSES. See page 15 for full Warranty Terms & Conditions.

Important Safety Instructions



FAILURE TO COMPLY WITH THESE SAFETY RECOMMENDATIONS AND LOCAL SAFETY REGULATIONS MAY RESULT IN SERIOUS INJURY, DEATH OR DAMAGE TO PROPERTY.

PLEASE READ CAREFULLY AND ENSURE THAT ALL SAFETY RECOMMENDATIONS AND REGULATIONS ARE CONSIDERED AND ADHERED TO.

Note: It is highly recommended that safety beams are included with all installations. Correctly installed safety beams will prevent the door from closing if a person or object is located within the door area. If the beam is broken during the door's downward travel it will reverse back to the open position.

This accessory must be used for all installations where the closing force is greater than 400N (40kg of force) as measured at the bottom of the door.

- This appliance is not intended for use by children or persons with reduced physical, sensory or mental capabilities, or lack of experience and knowledge, unless they have been given supervision or instruction by a person responsible for their safety.
- Do not wear watches, rings or loose clothing while installing or servicing a garage door opener. Ensure that gloves, safety goggles and suitable protective clothing is worn where appropriate.
- The opener must not be installed in a wet or damp space exposed to weather.
- The opener must not be used on a door with a wicket door (a door within a door).
- Keep garage door balanced. Do not let the opener compensate for a binding or sticking garage door. Binding, sticking or unbalanced doors must be repaired before installing this opener.
- To avoid serious personal injury from entanglement, remove all ropes, chains and locks connected to the garage door before installing the door opener.
- Installation and wiring must be in accordance with your local building and electrical codes.
- Install the wireless remote control (transmitter) in a location where the garage door is visible, at a height of no less than 1.5m and out of reach of children. Do not allow children to operate push buttons or transmitters. Serious personal injury from a closing garage door may result from misuse of the opener.
- Permanently fasten the Warning Labels in prominent places, adjacent to wall controls and on manual release cord as a reminder of safe operating procedures.
- Ensure that the safety reverse system is tested every month. The garage door must reverse on contact with a 40mm high object placed on the floor. Adjust if necessary and repeat test. Failure to adjust properly may result in serious personal injury from a closing garage door.
- Disconnect electric power to the door opener before making repairs.
- If the supply cord is damaged, it must be replaced by the manufacturer, its service agent or similarly qualified persons in order to avoid hazard.
- Frequently examine the door installation paying particular attention to the mountings, guides and curtain for signs of wear, damage or imbalance. Springs and hardware are under extreme tension and a fault can cause serious personal injury. Do not use if repair or adjustment is needed.
- Ensure that the opener is operated only when door is in full view, free of obstructions and the opener is properly adjusted. No one should enter or leave the garage while the door is in motion.
- Do not allow children to play near the door, or with door controls. Keep remotes away from children.
- The door may operate unexpectedly, therefore do not allow anything to stay in the path of the door.
- **SAVE THESE INSTRUCTIONS-** it is important for the safety of persons to follow all instructions.

An emergency key release must be installed if there is no pedestrian door or other access into the garage.

Package Contents

- (1) RD800 opener
- (2) Hand transmitter (2)
- (3) Wall transmitter
- (4) Installation Instructions
- (5) Warning label
- (6) Weight bar
- (7) Anti-coning collar (2)

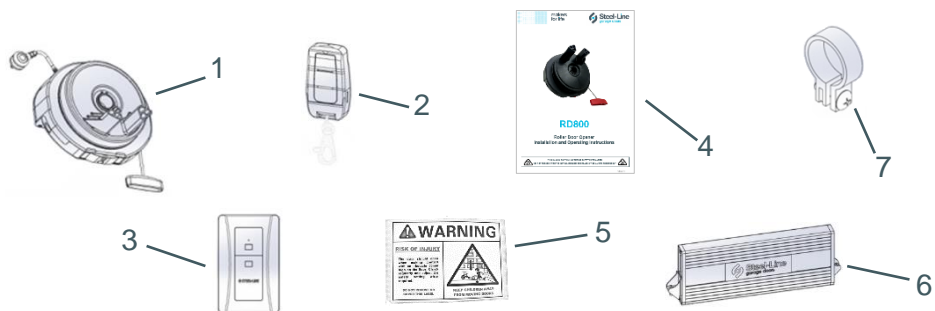

Tools Required

- (1) Ladder
- (2) Socket wrench
- (3) 13mm socket
- (4) Socket extension
- (5) Adjustable wrench
- (6) Phillips head screwdriver
- (7) Driver with phillips bit
- (8) Marker pen

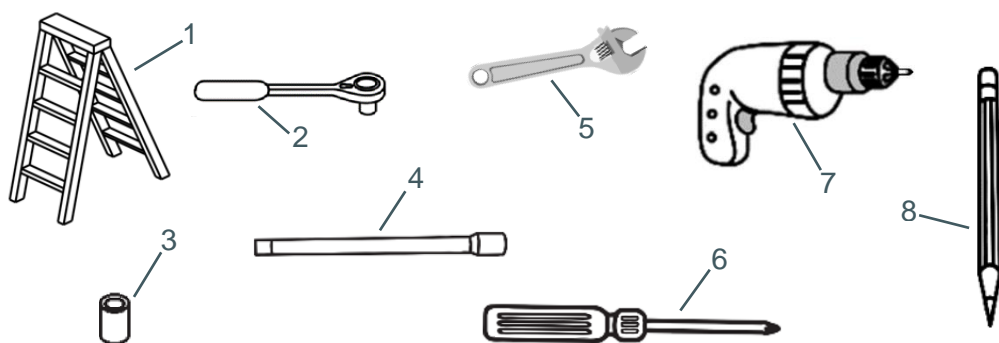

Door Requirements

- **The opener is not suitable for roller doors with wind locks.**
- The opener may be fitted to either the LEFT or RIGHT hand side of the roller door.
- Ensure there is a power point near the opener.
- The maximum allowable door height is 5.5m with a maximum curtain area of 18m². The door must be of continuous corrugated sheet construction and spring balanced. The door axle diameter must not exceed 35mm.

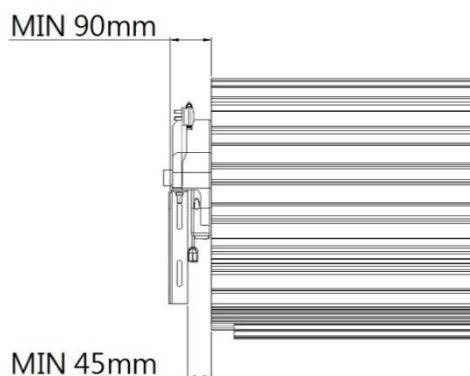

DOOR TYPE	SIDE CLEARANCE
A Series (25mm tracks)	90mm
AA/B Series (50mm tracks)	115mm

Ensure there is a minimum of 45mm from the edge of the curtain to the edge of the bracket. Additional clearance may be required if the roller door drum is on the edge of the curtain or is a smaller diameter. A fork extension kit may be required if the drum is more than 60mm from the edge of the curtain or a smaller diameter.

If the opener is being fitted at the same time as a new door, read these instructions in conjunction with the door installation instructions. If the opener is being fitted to an existing door, make sure the door is properly balanced and operates smoothly.

Testing the Door

The following test must be completed prior to installing the opener to ensure the roller door is well balanced and not sticking or binding:

- All locks must be disabled, and any ropes connected to the door must be removed.
- Lift the door approximately halfway and then release it. The door should remain spring balanced.
- Open and close the door to check for any binding or sticking points (20kgf is the maximum allowable to raise or lower the door in any position).
- Call a qualified door technician if the door does not hold in place or if it binds or sticks.

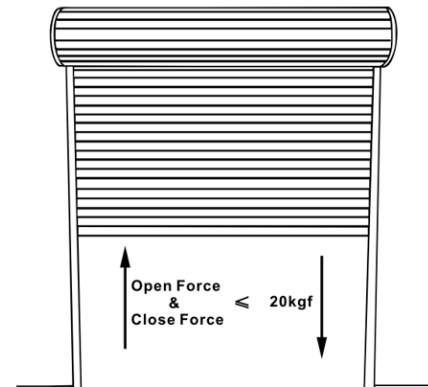

Installing the Weight Bar

A weight bar must be fitted to ensure the door does not balloon during operation.

1. Locate centre of door at the bottom rail and place the weight bar in this position.
2. Using the two self-taping screws fasten the weight bar to the bottom rail securely.

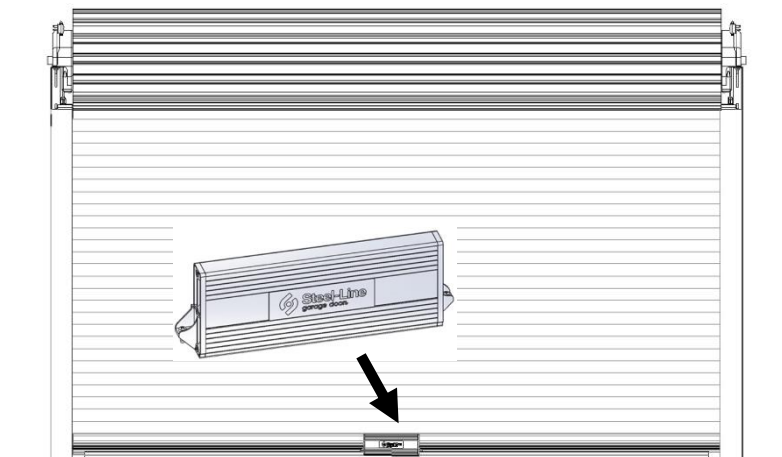

Installation Instructions

Do not allow anyone to walk around or under the door during the installation process as serious injury can occur.

STEP 1.

Fit the anti-coning collar against the drum wheel on the opposite end to where the opener is to be installed as shown in Fig 1. The anti-coning collar should be hard against the drum wheel and tightly secured to the door axle.

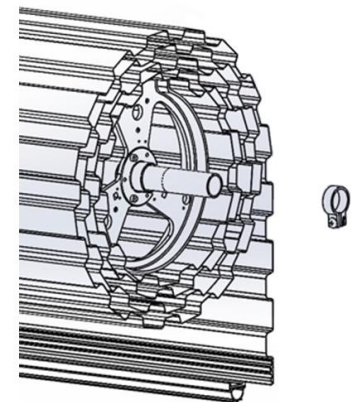

Fig 1.

STEP 2.

The safety reversal response may be delayed due to a ballooning door and can compromise garage security.

To prevent ballooning the curtain must be pinned by securely fixing self-tapping metal screws or rivets through the curtain and into the drum wheel. This must be done at both ends of the door. Fig 2. demonstrates how to determine the correct fastener location, where the curtain leaves the roll.

After determining correct fastener location, lift the door half a turn from closed position to allow access for drilling, see Fig 2.

STEP 3.

1. Ensure opener is in manual release mode, see below.
2. Open the roller door fully and tie a rope around the door for safety. The door should be supported with a door stand or similar device. See Fig 3.
3. Ensure that the door axle U-bolt on the opposite end of the door (to which the opener is to be fitted) is **TIGHTENED** securely. This U-bolt will hold all the spring tension on the door.
4. On the opener side mark the position of the door axle on the door mounting bracket (for reassembly purposes).
5. Remove the door axle U-bolt on the side where the opener will be installed and remove the door mounting bracket from the wall.
6. Slide the opener onto the door axle as shown in Fig 4. Ensure the drive forks engage fully with the narrowest spoke on the drum wheel. A fork extension kit may be necessary.
7. Refit the door mounting bracket to the wall.
8. Clamp the opener on the door axle and door bracket in the marked position using the clamp assembly supplied. Tighten firmly to 25-28Nm.
9. Remove all ropes and door support stand.
10. Check the operation of the door in manual mode by lowering and raising the door fully by hand. It should operate smoothly without sticking or binding.
11. Adjust the manual release cord so that the handle is no more than 1.8m above the floor.

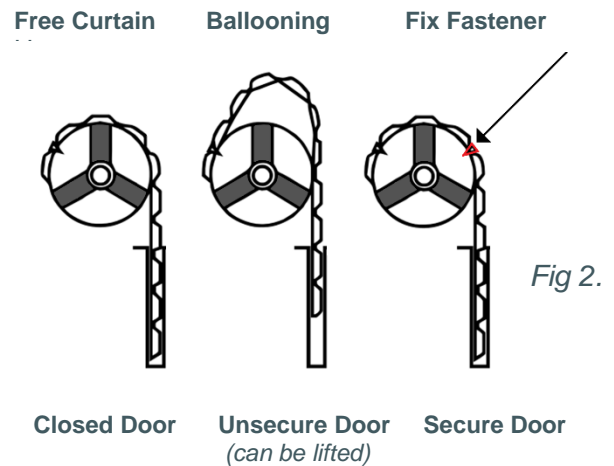

Fig 2.

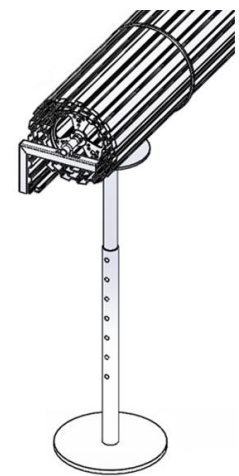

Fig 3.

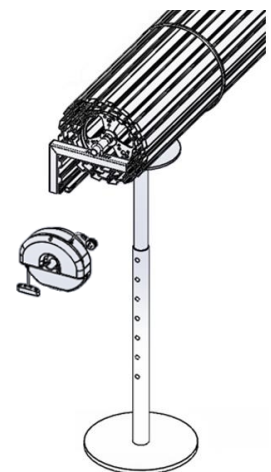

Fig 4.

Using the Manual Release

Care must be taken when operating the manual release. A door may fall rapidly due to broken or unbalanced springs.

To disengage the opener: Pull the release cord down firmly.

To re-engage the opener: Pull the release cord down firmly.

Ensure that all locks and ropes connected to the garage door are removed.

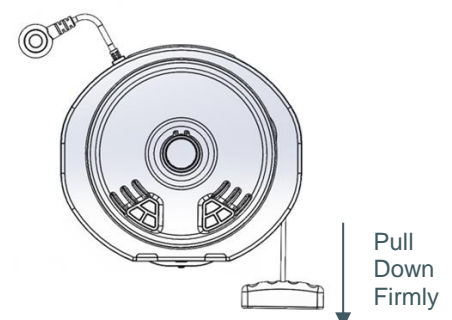

Control Panel

Button Functions



“LIMIT” Button

- Up & Down limit setting
- Open/Close door

“UP” Button (Up/Open)

- Opens the door
- Limit position adjustment (Up)
- Auto close/Force setting adjustment (Increase)

“DOWN” Button (Down/Close)

- Closes the door
- Limit position adjustment (Down)
- Auto close/Force setting adjustment (Decrease)

“LEARN” Button

- Programming/Deleting transmitter

“FORCE” Button

- Overload sensitivity adjustment

LED Indicator Lights

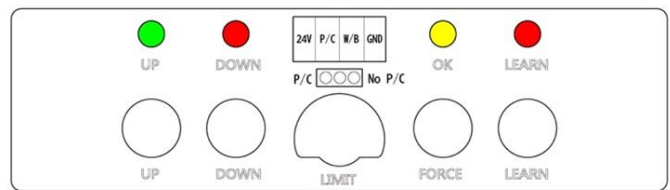

UP Green

- Left handed direction/Open

DOWN Red

- Right handed direction/Close

OK Yellow

- Setting confirmation

LEARN Red

- Programming/Deleting transmitter

Push down RED for right hand Motor
Then set the Limits as below

Notes Early model motors have to have the limits reset to reset the service counter to 2,500

Late Model motors you push limit set and Open together for 6 seconds and a beep is heard then set for 1,000 openings then do again then set for 2,000 then again to set for 2,500 openings as max settings.

Setting Direction of Operation

The direction of operation must be programmed before proceeding to the travel limit setting procedure.

Ensure the power is switched on before proceeding.

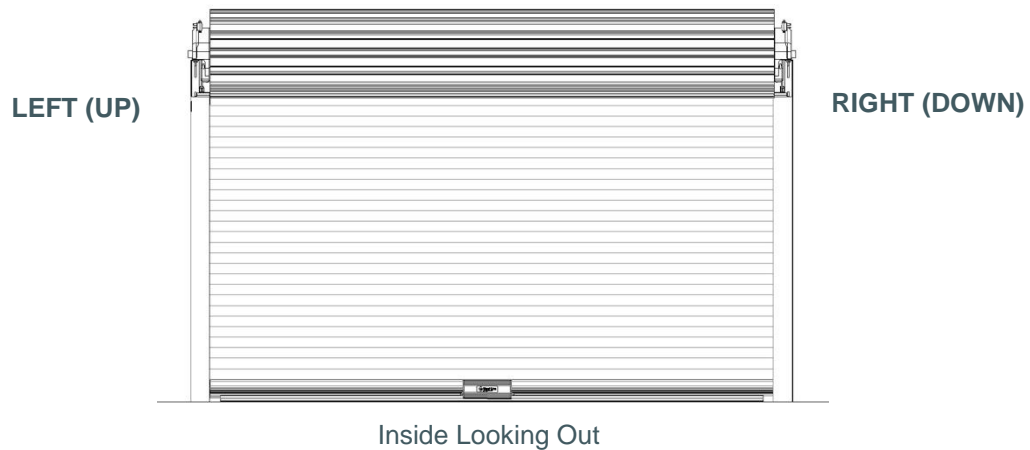

Direction Setting Procedure

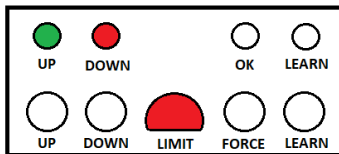

- ❖ Press and hold the “LIMIT” button for 5 seconds (*unit will beep once and UP LED & DOWN LED will turn on*).
- ❖ Press the “UP” or “DOWN” button once to select the direction required.
- ❖ The corresponding LED will turn on to indicate selection.
- ❖ Unit will then beep three times and will automatically enter Limit Setting Mode (*the UP LED will turn on*).
- ❖ Proceed to Setting Travel Limits, page 8.

Setting Travel Limits

CAUTION: Make sure the opener is set for the correct side of installation before proceeding!
See page 7.

The travel limits regulate where the door stops when you operate the door UP and DOWN. Manually position the door at the halfway position and re-engage the opener by following the instructions on Page 5, *Using the Manual Release*.

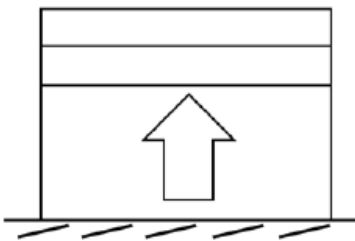
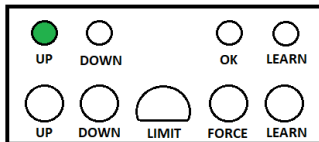

Following on from the Direction Setting Procedure on page 7 the UP LED should now be on.

STEP 1.

- ❖ Press and hold the “UP” button to bring the door to the desired open position.
- ❖ At this point you can make slight adjustments “UP” and “DOWN” until the door is in the desired position.
- ❖ Press the “LIMIT” button once. Unit will beep twice and DOWN LED will flash.

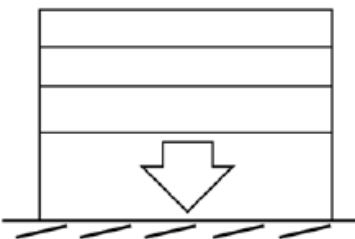
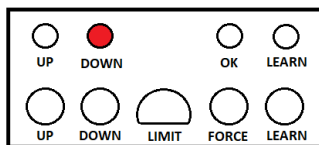

STEP 2.

- ❖ Press and hold the “DOWN” button to bring the door to the desired closed position.
- ❖ At this point you can make slight adjustments “UP” and “DOWN” until the door is in the desired position.
- ❖ Press the “LIMIT” button once. Unit will beep twice. The opener will automatically operate a full cycle to remember the limit positions. Unit will sound one long beep and then it will return to normal operating mode.

Note: Open and close the door 4 times using the “LIMIT” button to ensure the limits are correctly set. After checking the position, it is important to now test the safety reverse feature, see below.

Safety Reverse Test

It is important that a safety reverse system test is carried out. The garage door must reverse on contact with a 40mm object placed flat on the floor. Incorrect force adjustment can result in serious injury.

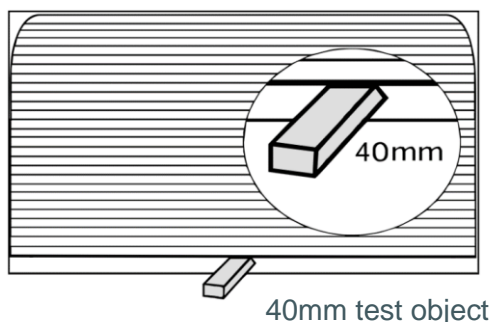

Operate the door to the closed position with the object in place under the door. The door must reverse upon contact with the object. If the door stops, but does not reverse, adjust the safety reversal force, see page 9.

Always repeat safety reverse test after adjusting force.

Safety Reversal Force Adjustment

The force, as measured at the bottom of the door, should not exceed 400N (40kgf). If this force is exceeded safety beams must be installed.

The maximum force is 5 and the minimum force is 1. The default force is set to 2. Force settings are automatically set when cycling the door after the Travel Limit Setting Procedure. Manual adjustment should only be carried out by a suitably qualified technician if required.

ADJUSTING THE OPEN FORCE

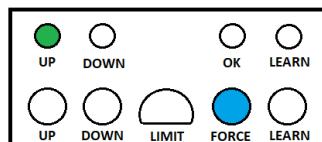

- ❖ Press and hold the “FORCE” button for 2 seconds (*UP LED will turn on*).
- ❖ Press and release the “UP” button to increase the force or the “DOWN” button to decrease the force to the desired setting.
- ❖ Unit will beep once for level 1, twice for level 2 etc. and then it will return to normal operating mode.

ADJUSTING THE CLOSE FORCE

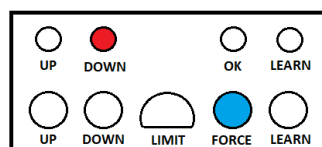

- ❖ Press and hold the “FORCE” button for 2 seconds then release.
- ❖ Press and release the “FORCE” button once (*DOWN LED will turn on*).
- ❖ Press and release the “UP” button to increase the force or the “DOWN” button to decrease the force to the desired setting.
- ❖ Unit will beep once for level 1, twice for level 2 etc. and then it will return to normal operating mode.

Open and close the door once for the unit to remember the force after every force adjustment.

Reset Opener

Follow the below procedure to reset the opener back to factory default settings.

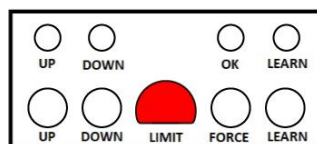

- ❖ Unplug the power cord then hold the “LIMIT” button.
- ❖ Plug the power cord then release the “LIMIT” button.
- ❖ Unit will sound one long beep and two short beeps to complete hard reset.

The opener has been restored to factory default settings and must be reprogrammed again.



IMPORTANT SAFETY NOTICE: After programming opener always conduct a safety check to test safety reversal system. Activate the opener only when door is in full view and free of obstruction. No one should enter or leave the garage while the door is in motion.

Warning Labels

The warning label should be installed in a prominent position near the opener.

The manual release handle should be no higher than 1.8m from the floor. The wall control, or wireless wall button, should be mounted no less than 1.5m from the floor **out of reach of children**.

Read Important Safety Instructions on page 2.

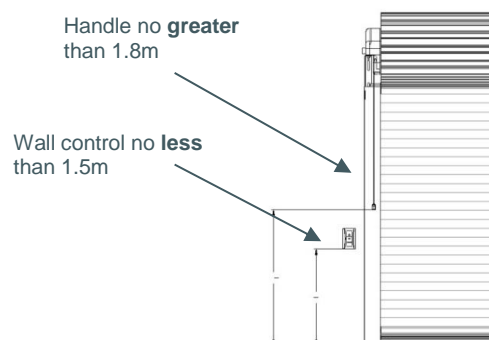

Coding Wireless Transmitters

The two (2) hand transmitters (remotes) and wireless wall switch supplied with your opener are preprogrammed at the factory.

Additional transmitters can be coded as follows:

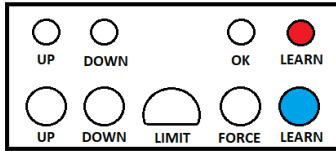

- ❖ Press the “LEARN” button once (*LEARN LED will turn on and unit will beep three times*).
- ❖ Within 10 seconds, press and release the required push button on your remote once.
- ❖ All LED’s will switch off indicating that the transmitter has been successfully programmed.
- ❖ If the transmitter has already been memorized by the opener the unit will beep twice.

If you fail to press the transmitter button whilst in coding mode within 10 seconds, the opener will automatically return to standby mode.

Note: A maximum of 15 codes can be learned by the opener. If you want to program another transmitter and the memory is already full you will need to clear all data and program transmitters again.

Deleting transmitters:

Note: This procedure will clear all programmed remotes, wireless wall buttons and wireless keypads from the opener.

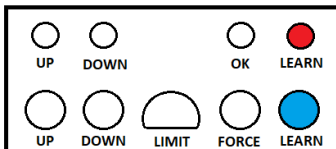

- ❖ Press and hold the LEARN button for seven seconds (*LEARN LED will turn on with three beeps, unit will beep another two times followed by one long beep*).
- ❖ All LED’s will switch off indicating that all codes have been deleted and that the opener is now in normal operating mode.

Follow Procedure 1. above to code new transmitters.



IMPORTANT SAFETY NOTICE: After programming opener always conduct a safety check to test safety reversal system. Activate the opener only when door is in full view and free of obstruction. No one should enter or leave the garage while the door is in motion.

Safety Beam Installation (Optional Accessory)

Note: This accessory must be used for all installations where the closing force is greater than 400N (40kg of force) as measured at the bottom of the door. It is highly recommended that safety beams are included with all installations. Correctly installed safety beams will prevent the door from closing if a person or object is located within the door area. If the beam is broken during the door's downward travel it will reverse back to the open position.

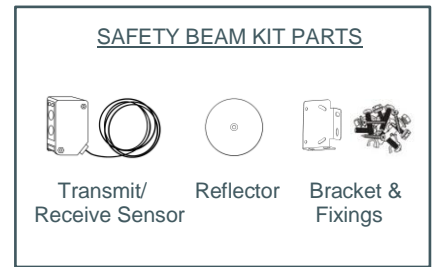

STEP 1.

Mount sensor bracket no higher than 100mm from the floor on side of door below opener, behind the tracks, ensuring it does not obstruct the door movement. Ensure that the reflector is aligned on the opposite side of the door, facing the sensor. Avoid positioning the sensor and reflector in direct sunlight as this could interfere with the operation of the safety beams.

STEP 2.

Note: Ensure power is disconnected from opener before continuing.

Run the wire from both sensors back to the opener ensuring that they are well supported and ensuring they don't interfere with the movement of the door. Connect the wires to the green terminal block as per the diagram and insert the terminal block into the opener. Ensure the mini jumper is placed on the jumper terminal as per the diagram.

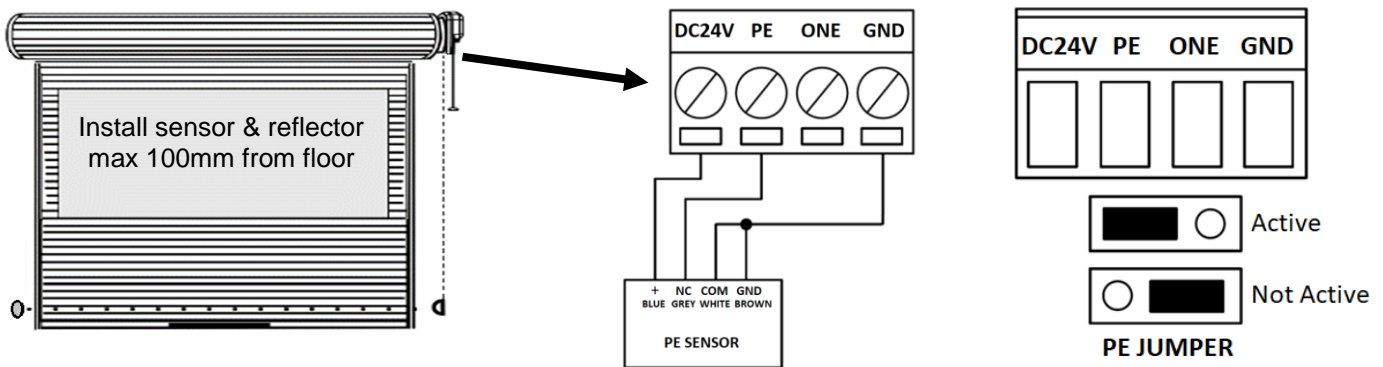

Auto-Close Timer

Safety Beams must be installed to activate this feature.

When the Auto-Close Timer is enabled the door will close automatically after a preset period of time (10 - 40 seconds). During the door open waiting period the LED courtesy lights will remain on. If an obstruction is detected during closing, the door will fully open and the Auto-Close Timer will begin again.

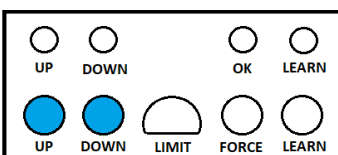
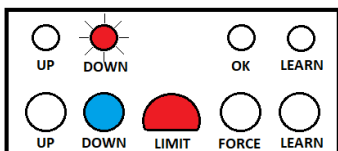

STEP 1.

Press and hold the "LIMIT" and "DOWN" buttons for 3 seconds until the DOWN LED flashes.

STEP 2.

Using the "UP" and "DOWN" buttons increase or decrease the time selection from no auto-close to 40 seconds in sequence.

- ⇒ One beep = no auto-close
- ⇒ Two beeps = 10 seconds
- ⇒ Three beeps = 20 seconds
- ⇒ Four beeps = 30 seconds
- ⇒ Five beeps = 40 seconds

The unit will save the setting and beep once, 3 seconds after selecting the desired time interval.

Maintenance Reminder



A poorly maintained door can cause property damage and result in serious or fatal injury.

Regularly check the following:

- ✓ Spring tension of your door by manually lifting it up and down.
- ✓ All fittings should be secure.
- ✓ Carry out the safety reverse test monthly, see page 8.
- ✓ Tracks should be regularly cleaned with a soft, damp cloth with methylated spirits or mineral turpentine. Never lubricate/grease tracks.

Adjustments to the door should only be carried out by an experienced garage door professional.

Failure to properly maintain your garage door and opener may void your warranty.

Technical Specifications

Electrical Specifications

Electrical Input	220-240V, 50/60Hz
Standby Power	<3W

Motor

Type	24V DC
Max Driving Force	800N
Max Drum Rotations	5.5

Door Details

Max Door Size	18m ²
Max Door Weight	110kg
Max Lift under Spring Tension	20kg
Max Door Height	5500mm
Travel Time	200mm/s

Dimensions

Dimensions	280mm (L) x 190mm (W) x 260mm (H)
Weight	5.7kg

Safety

Personal	Push button stop in UP and DOWN direction. Automatic safety reversal on closing and stop on opening.
Electronic	Automatic force adjustment
Limit Adjustment	Electronic
Feature	Soft start/stop

Courtesy Light

Type	12V LED (4 x ultra bright)
Lighting Time	2 minutes

Transmitter

Frequency	433.92Mhz
Coding Type	Rolling Code
Memory Register	15 handset codes
Operation Range	35m approx.
Battery	6V (CR2016) x 2

Troubleshooting

<p>The opener does not work from either door control or remote hand transmitter.</p>	<ul style="list-style-type: none"> • Does the opener have power? • If there is no light, check the fuse box or circuit breaker. • Check plug and contact an electrician if the power point is faulty.
<p>Opener operates from door control but not from remote hand transmitter.</p>	<ul style="list-style-type: none"> • Opener antenna is loose or not extended. • There may be interference nearby. • Flat battery. If necessary, replace battery in remote. • Follow procedure on page 10 to reprogram your remote.
<p>Remote hand transmitter has short range.</p>	<ul style="list-style-type: none"> • If necessary, replace battery in remote. • Change location of remote control in the car. • A metal garage door, foil insulation or metal side walls will reduce the transmitter range.
<p>The door opens and closes by itself.</p>	<ul style="list-style-type: none"> • Check to ensure that remote push button is not stuck on. • Delete all transmitter codes, see page 10. • Reprogram each remote to the opener, see page 10.
<p>Cannot code new transmitters.</p>	<ul style="list-style-type: none"> • Memory is full. Delete all stored transmitters and recode a maximum of 15 transmitters, see page 10. • New transmitter is not compatible with opener. Replace with genuine transmitters only.
<p>The door automatically reverses to the open position before closing completely.</p>	<ul style="list-style-type: none"> • If door is not correctly balanced call a garage door professional to correct the problem. • Re-set the travel limits, see page 8. • Increase the safety reversal force, see page 9.

Warranty

Product: RD800 Roller Door Opener



This warranty is provided by Steel-Line Garage Doors, hereafter referred to as the manufacturer.

What is covered under this Warranty

1. When installed by a professional garage door technician in a residential/domestic single-family dwelling with a residential garage door, the manufacturer warrants to the original purchaser:
 - a) that the Product's drive unit will be free from defects in components and workmanship for a period of five (5) years, or 10,000 cycles (each opening & closing action of the garage door equals one cycle), whichever occurs first, from the date of purchase;
 - b) that the electronics and mechanics will be free from defects in components and workmanship for a period of two (2) years;
 - c) that all other components and accessories, including remote controlled transmitters included with the Product will be free from defects in components and workmanship for a period of 12 months.

For all Products repaired outside of the warranty period by the manufacturer, a three (3) month warranty will apply to the work that has been carried out.

What is not covered under this Warranty

1. Batteries, fuses, globes, sensitivity and limit switch adjustment, transmitter and receiver range, labour and travel are not covered under this Warranty.
2. No additional warranty will apply for Products repaired during the warranty period.

Warranty Conditions

1. Sales docket or invoice must be retained to verify proof of purchase and date of installation.
2. A return to base warranty applies and does not cover labour for on-site attendance unless the opener has been installed by the manufacturer. Return to base indicates that the opener must be returned to the manufacturer for repairs or replacement in original or suitably secure packaging.
3. The garage door that the Product is used with must be spring balanced in such a way that the user is able to open and close the door by hand with a force no greater than 20kg.
4. The garage door must not weigh more than 110kg.
5. The garage door and the Product must be professionally maintained and serviced regularly, in accordance with the instructions provided with the Product, as a minimum every 12 months or 1,500 cycles.
6. If the garage door is out of balance, sticks or binds, it must not be used until serviced by a professional garage door technician.
7. It is a condition of this Warranty that the Product must be installed and maintained by a professional garage door technician.
8. If the Product is purchased over the internet from an online reseller the manufacturer accepts no responsibility for determining the suitability of the Product and accepts no responsibility for unauthorised installation. For online purchases, the manufacturer will warrant to the original purchaser that all parts of the Product will be free from defects in components and workmanship for a period of 12 months or 1,500 cycles from the date of purchase. All online purchase claims must be directed through the online reseller.

Making a claim

During the warranty period if you suspect the Product may be defective, contact the retailer that you purchased the Product from or contact our technical support team and they will diagnose the issue and arrange for rectification.

Exclusions to this Warranty

If a warranty claim has been made due to a failure or defect arising under or out of any exclusion detailed below, the manufacturer may charge you a fee to repair, replace and/or return the Product to you.

The manufacturer will not cover any Product failure or defect due to:

1. non-conformity with the instructions concerning installation, maintenance, operation and testing of the Product;
2. installation of the Product in commercial or industrial premises or in a dwelling other than a single-family dwelling;
3. modification, adjustment, repairs or relocation of the Product by an unauthorised person;
4. problems relating to garage door hardware including springs, rollers, hinges, door alignment or other issues associated with lack of proper maintenance by a professional garage door technician;
5. normal wear and tear;
6. use of any imitation or copy remote transmitters with the Product;
7. water damage or condensation that causes corrosion or electrical malfunction;
8. corrosion or problems due to installation within 800m of the sea or body of water of equivalent or greater salt concentration;
9. electrical storms, power strikes, power surges, fire, water, flood, rain or other acts of God;
10. problems caused by blown fuses, replacement of batteries or light bulbs;
11. damage caused by insects or pests;
12. radio or electrical interference;
13. misuse, tampering, neglect, abuse, accidents or damage beyond the manufacturer's reasonable control.

Liability

Subject only to the provisions of the Trade Practices Act and any legislation of the state or territory wherein the Products of the company shall have been sold or installed (which may confer certain rights on consumers of goods and those rights by such legislation may be rendered incapable of exclusion) this warranty supersedes and excludes all representations, warranties and conditions whether expressed or implied by law and the company shall have no liability or otherwise that herein provided for any loss and damage (including consequential loss and damage, loss of use or profits) by reasons of delay, defective or faulty materials or workmanship, negligence or any act, matter or thing done permitted or omitted to be done by the company.

Notes

Our goods come with guarantees that cannot be excluded under the Australian Consumer Law. You are entitled to a replacement or refund for a major failure and compensation for any other reasonably foreseeable loss or damage. You are also entitled to have the goods repaired or replaced if the goods fail to be of acceptable quality and the failure does not amount to a major failure.

Steel-Line Garage Doors reserves the right to change our warranty, terms and conditions at any time without notice. We will constantly review our warranty and return policy to improve or update new information. Any changes to the policy will be updated on our website warranty page.

Steel-Line Automation
27 Clinker Street
Darra QLD 4076

Phone: 1300 007 081
Web: steel-lineautomation.com.au
Email: automation@steel-line.com.au