

Smart Lifter

Sectional Door Opener

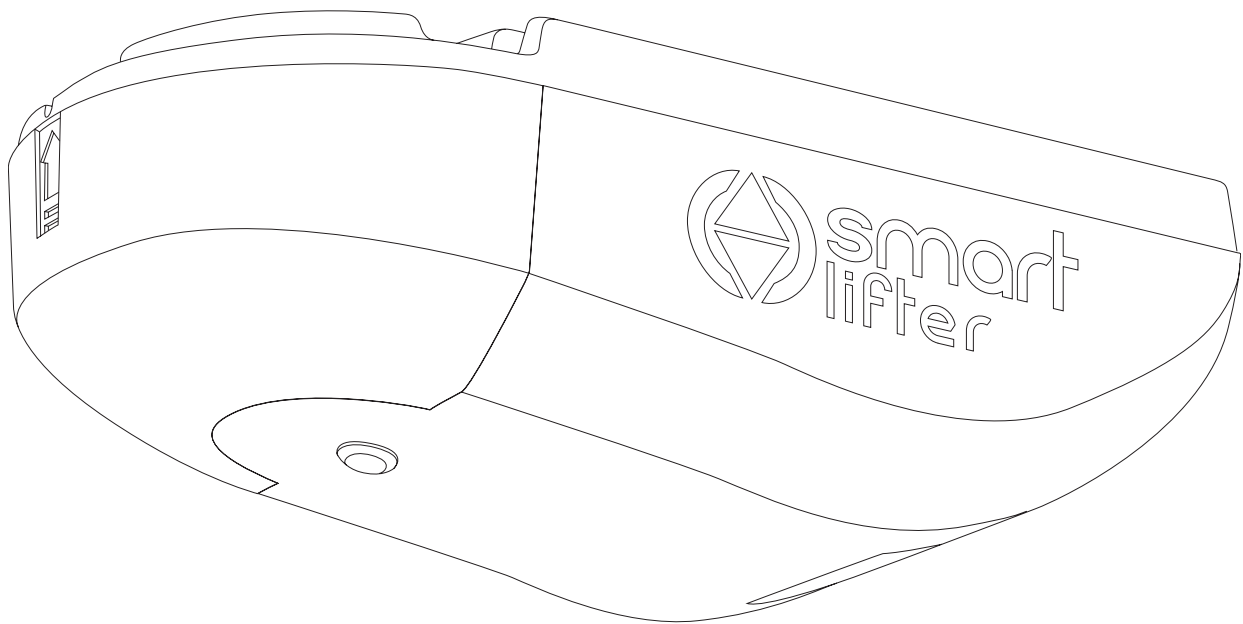

Note: If you ever get one of these opening and closing by itself and it has a hard wired wall button Unplug it as I have found the wire if its telephone wire can trigger the door off for no reason by interference.

WARNING: IT IS VITAL FOR THE SAFETY OF ALL PERSONS INSTALLING AND USING THIS OPENER TO FOLLOW THE INSTALLATION INSTRUCTIONS AND SAFETY WARNINGS. FAILURE TO COMPLY MAY RESULT IN SERIOUS PERSONAL INJURY AND/OR PROPERTY DAMAGE AND FAILURE OF THE OPENER SYSTEM.



INSTALLATION MANUAL

Index

CONTENTS	3
IMPORTANT SAFETY WARNINGS	3
DESCRIPTION	3
OPERATING CONTROLS	4
INSTALLATION INSTRUCTIONS	5
SHORTENING THE TRACK	6
INSTALLING SHUTTLE STOP	8
DESCRIPTION OF THE CONNECTIONS	8
PROGRAMMING THE UNIT	8
SETTING OF OPEN AND CLOSE POSITIONS	9
ADJUSTMENTS	9
FUNCTION MODES	9
PHOTO BEAMS	9
TO SET AUTO-CLOSE ON/OFF	9
TO SET TIME DELAY FOR AUTO-CLOSE	9
SELF-LEARNING TRANSMITTER	10
MAINTENANCE	10
TECHNICAL SPECIFICATIONS	10
FINAL NOTES	10
INFORMATION FOR THE USER	11
WARRANTY	12

To the extent that they may be lawfully excluded, Smart Openers Pty Ltd hereby expressly excludes all conditions and warranties, statutory or otherwise, which may be implied by law as conditions or warranties of purchase of a Smart Openers Pty Ltd Garage Door Opener. Smart Openers Pty Ltd hereby further disclaims and rejects to the maximum extent permitted by law any liability or responsibility whatsoever for any direct, indirect, consequential, incidental or other injury, damage, cost, expense or loss whatsoever incurred or suffered by any person, company, firm or organization as a result of any failure to install the Garage Door Opener in accordance with these installation instructions.



Contents

No	Package	Part			
1	Motor	No	Description	Qty	Remark
		1	Motor	1 Set	
		2	Transmitter	2 Pcs	Transmitter
		3	Remote Wall Switch	1 Pc	
		4	Remote Wall Switch Bracket	1 Pc	
		5	Disengagement Cord	1 Pc	
		6	Clutch	1 Pc	
		7	Bracket	1 Pc	For Track
		8	Bracket	1 Pc	For Door Panel
		9	Strapping	4 Pcs	For Rail
		10	Connector	2 Pcs	For Door Panel
		11	Bolts/Nuts	1 Set	
		12	Installation Manual	1 Pc	
13	Owners Manual	1 Pc			
2	Rail	1	Extrusion	1 Set	

Important Safety Warnings

The Smart Lifter garage door opener described in this manual is designed for the automation of residential sectional overhead doors and one piece overhead tilting doors. Any other use is considered improper and will void the warranty.

WARNING:

You are carrying out operations on machine systems classified in the automatic gates and doors category and as such failure to comply with the relevant safety rules may result in serious personal injury and/or property damage. Reference to the safety rules can be found on pages 2-4 of the owners manual and should be read and understood prior to installation.

Only qualified personnel should install and service the equipment. It is the responsibility of the installer to adhere to all relevant safety standards.

The Smart Lifter opener is designed and manufactured to meet all current Australian standards and it is

essential that the installer also installs the equipment in accordance with all local and Australian regulations.

Unqualified personnel or those who do not know the occupational health and safety standards applicable to automatic gates and doors category must under no circumstances carry out installations or implement systems.

Persons who install or service the equipment without observing all the applicable safety standards will be held responsible for any damage, injury, cost, expense or claim whatsoever suffered by any person as a result whether directly or indirectly from failure to install the system correctly and in accordance with the relevant safety standards and installation manual.

For a more detailed list of the Safety Warnings and safety Issues associated with the installation and use of a Smart Lifter sectional door opener refer to the safety warnings in the OWNERS MANUAL.

Description

The Smart Lifter garage door opener requires a 240VAC 50Hz power input and has a 24V DC 100W motor and can provide 'Hold to Run' control and automatic modes for operation. When the door is in operation, movement can be interrupted by activation of the safety inputs (manual pull cord, transmitter, wall button (if fitted) and photo beams (if fitted).

An encoder sets open and close positions and braking during the end of the travel cycle reducing speed and noise.

A 433.22MHz radio receiver is built into the circuit board and the rolling code is memorised with the self-learning technique. As an alternative to the built-in receiver the unit will accept any of the range of stand alone radio receivers. The unit has been designed to provide maximum reliability, safety and flexibility of use.

IMPORTANT:

Before starting to install the unit read all of the instructions carefully and make sure you are familiar with the safety warnings included in this manual and in the OWNERS MANUAL.

Operating Controls

- 1 (UP button) Limit mode set.
- 2 (DOWN button) Reversing sensitivity set
- 3 (SET Button) Confirm set
- 4 (CODE Button) Transmitter code set

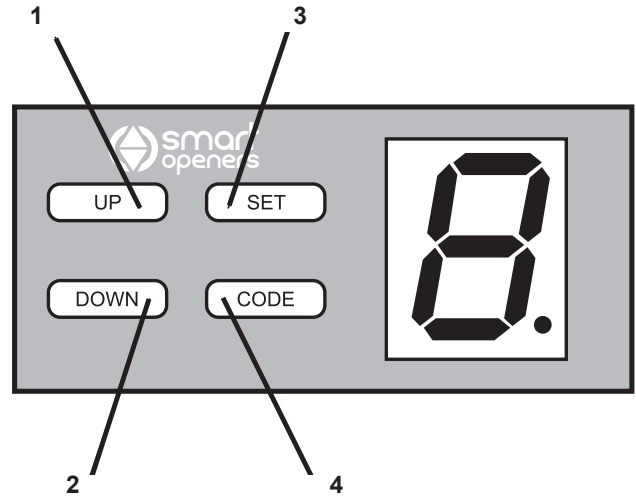

Circuit Board Connectors

- 5 Coupling for connecting the backup battery.
- 6 Coupling for connecting the motor.
- 7 Coupling for the power transformer.
- 8 Terminal for connection of power input, run lamp and transformer.
- 9 Terminal connector to control board.
- 10 Terminal for connection of photo beam or push button.

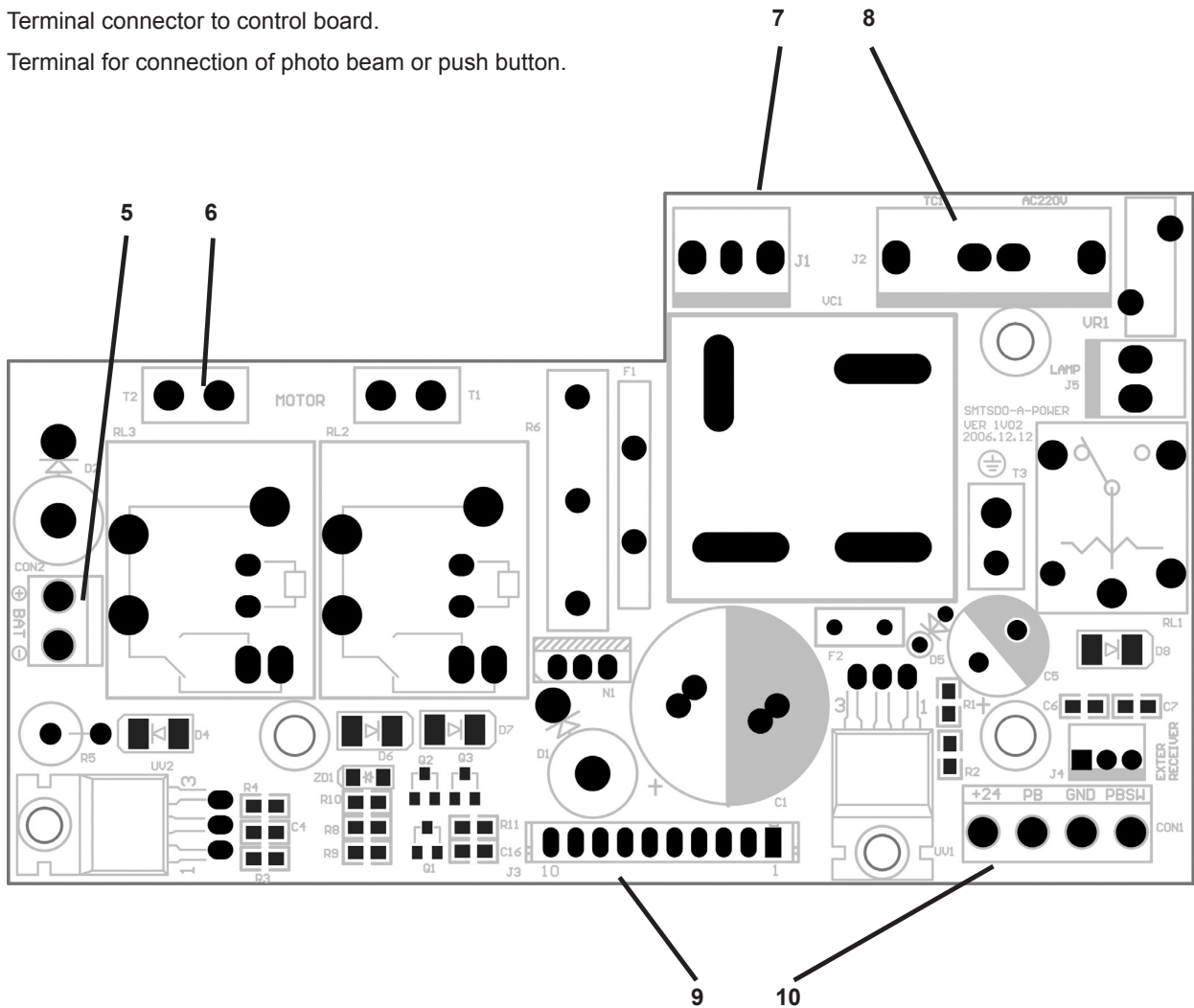

Installation

Remember there are specific standards that have to be strictly followed regarding the safety of electrical installations and automatic gates and doors.

As well as the legal requirements and standards that must be adhered to, please take note of the following points to ensure maximum safety and reliability of your installation.

- 1.1) Prior to installing check the surrounding environment. Carefully evaluate any hazards there could be from physical damage (transiting vehicles, parts of trees falling etc.), possible contact with foreign bodies (insects, leaves, etc.), Flooding hazards or any others exceptional events.
- 1.2) Check that the main voltage is the same as that given on the rating plate and in this manual.
- 1.3) Check there is suitable electrical protection against short circuits/power spikes and proper earthing on the main supply.

Remember the unit has mains voltage running through it (electrocution hazard, fire hazard).

- 1.4) Take care with the control unit; parts may be subject to damage if abused.
- 1.5) Make sure you have all the necessary materials and that they are suitable for this kind of use.

- 1.6) Read all the instructions thoroughly and make sure they are understood before attempting to install the Smart Lifter.
- 1.7) Before starting the installation, carefully analyse all the risks relating to automating the door. Verify that the door to be automated is in a sound condition and that the mechanisms are in good working order; observe the safety margins and minimum distances.
- 1.8) Evaluate with particular care the safety devices to be installed and where to install them; always install an emergency stop device for interruption of power to the opener if required.
- 1.9) Once the risks have been analysed, install the Smart Lifter opener and relative safety devices, emergency stop and/or photoelectric cells.

Important: For additional safety Smart Openers Pty Ltd strongly recommends the fitting of Photo Electric safety beams on all installations.

- 1.10) When installing the Smart Lifter opener, strictly follow all the instructions given in the instruction manual. If some points or procedures in this manual are not very clear do not install the unit until all doubts have been cleared up with our technical department.

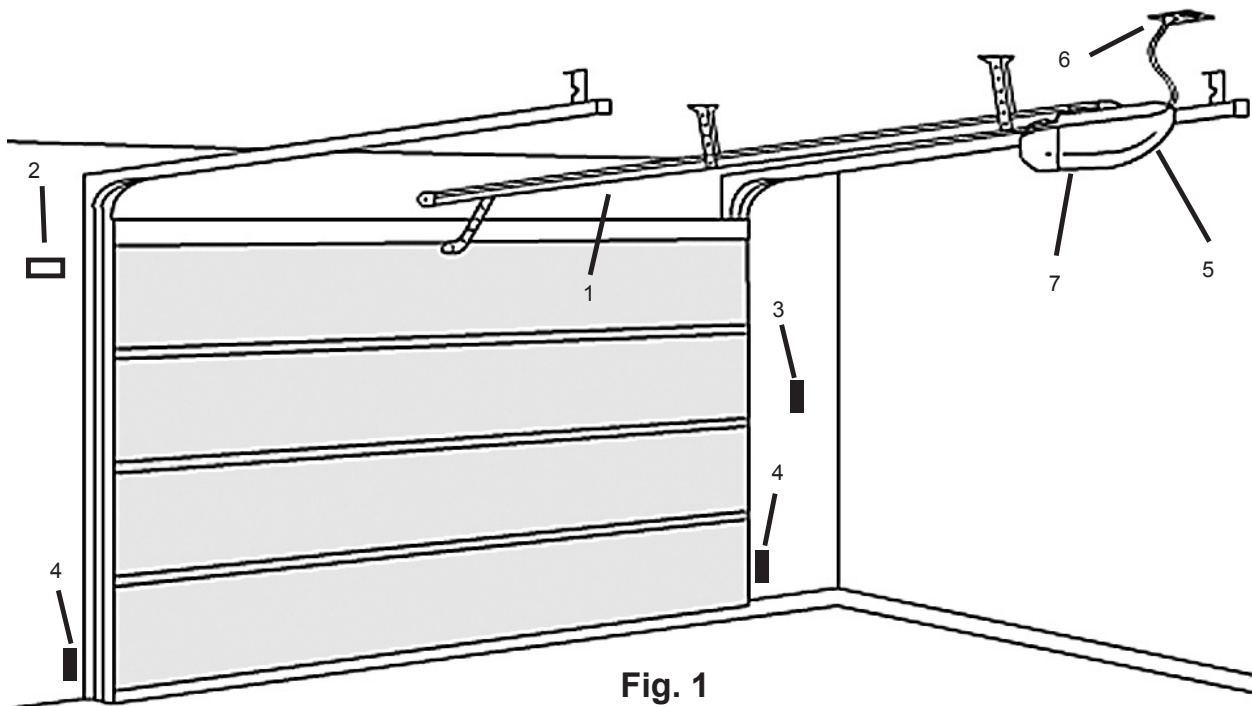

Fig. 1

Refer to above for recommended installation

- | | |
|---|-----------------------------|
| 1) Smart Lifter sectional door opener | 5) Inside push button panel |
| 2) 24V DC flashing light (optional extra) | 6) Power point |
| 3) Key selector switch or digital keypad | 7) Power head |
| 4) Photo beam (RX/TX Type) | |

Installation

- 1) Read the instructions carefully.
- 2) Make sure the door structure is solid and suitable to be motor driven.
- 3) Make sure that when the door is moving there are no friction points.
- 4) The door must be properly balanced and must be easily lowered and raised by hand.
- 5) Install a 240V, adequately protected 3-pin socket near where the Smart Lifter opener is going to be installed

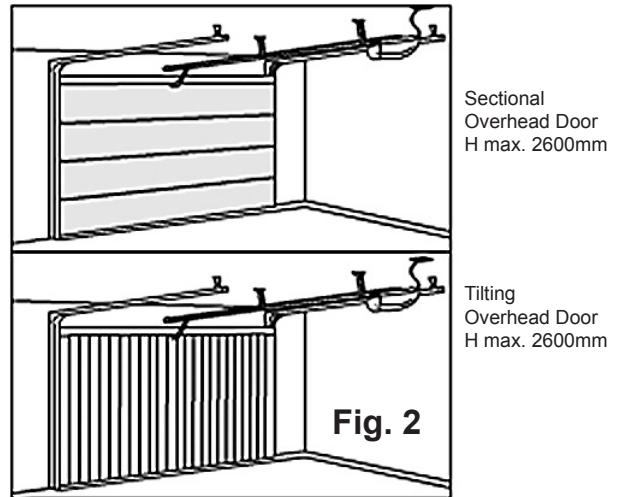

CHAIN SHUTTLE ASSEMBLY

For ease of installation the Smart Lifter is delivered with the chain and chain index already assembled in the track. If you need to assemble it yourself connect the chain index to the chain refer (Fig. 3). Tighten screw (C) (Fig. 4 B) until the chain is reasonably tight. Do not over tighten, but do not leave it too slack.

SHORTENING THE TRACK

The track is designed to be cut to size only if and when required. This should only be done when space is at a premium due to a lintel or some other obstruction. Cut the track down to the desired size from the bracket end only (not from the power head end). Remove the appropriate amount of chain links with a chain breaker. Reinstall chain in track and connect chain index as per (Fig. 3) above. Tighten screw (c) (Fig. 4b) until the chain is reasonably tight. Do not overtighten but do not leave it too slack.

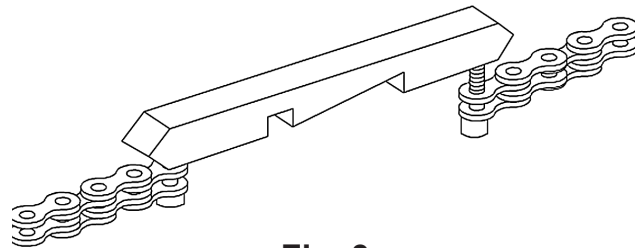

Installation

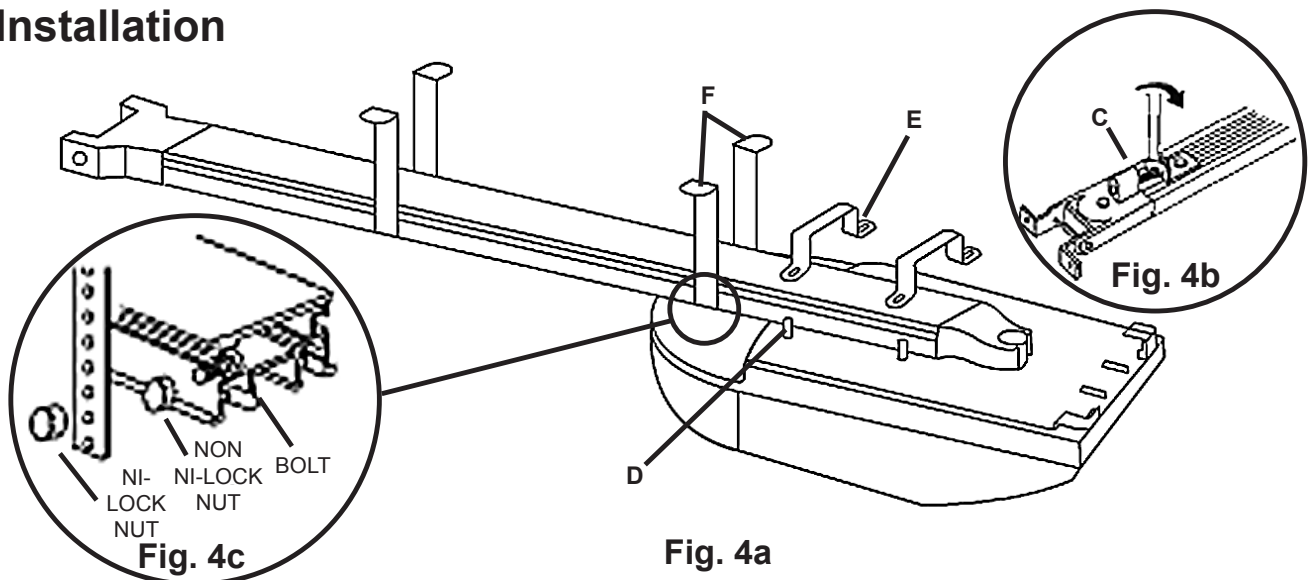

Fig. 4a

- 2.1) Insert shuttle into track by locating the cut out in the bottom of the track at the powerhead end of the track. It is important that the allen key bolt where the arm connects onto the shuttle is facing the door. Do not install it the wrong way round.
- 2.2) Move shuttle to half way along the rail section, grease the chain and sprocket with a lithium type grease or equivalent. Do not use oil based lubricants.
- 2.3) Place track onto powerhead so that the track slides into spline shaft. Position the brackets (E) on the studs and secure in place using ni-lock nuts supplied. Lock the brackets to the rail by tightening the ni-lock nuts. Do not over tighten the nuts.
- 2.4) Remove excess chain slack by tightening the chain tightening screw (C) in (Fig. 4b) in a clockwise direction (when viewed from the power head end of the rail). Do not over tighten the chain, just enough to remove the slack.
- 2.5) Fix the Smart Lifter opener to the lintel or to the ceiling with the correct fixing (Fig. 5), maintaining a minimum gap of 30mm from the top panel's maximum height (Fig. 6). Check measurements before drilling.
- 2.6) Insert the bolts supplied into the cutouts on both sides of track at powerhead end. Slide bolts on track to the correct hanging location to pick up noggins or fixing points. Place non ni-lock nuts onto the bolt (ref Fig. 4c) and tighten. Place bracket (F) onto bolt so that it sits against the nut and secure with ni-lock nut supplied - do not over tighten. Smart Openers recommend the fitting of all four straps on every installation.
- 2.7) Fix the Smart Lifter opener to the ceiling with appropriate fasteners (Fig.7). Cut off any fixing strap excess.

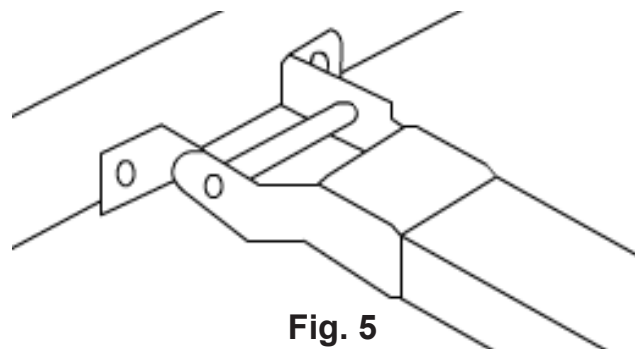

Fig. 5

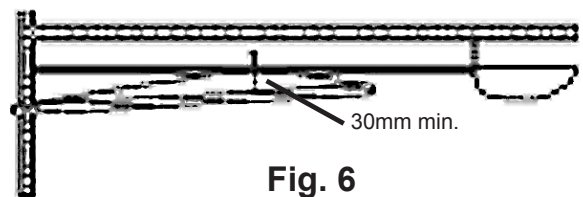

Fig. 6

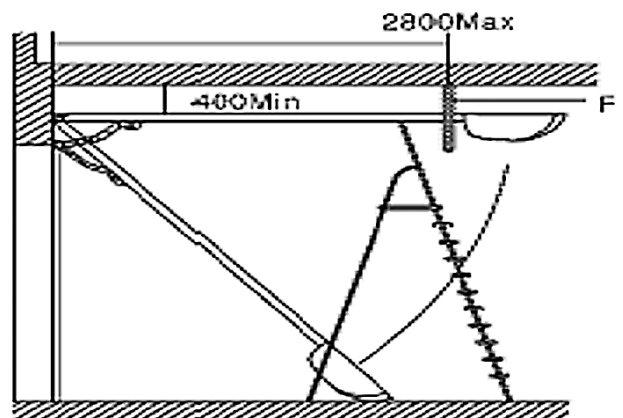

Fig. 7

- 2.8) Assemble straight arm and hockey stick using bolts and nuts provided. Connect arms to door bracket with pin and retainer clip and arms to shuttle on opener with allen head bolt provided in shuttle.

Warning: Make sure the opener is affixed to noggins in ceiling and not just to plasterboard. Failure to have a safe and secure fixing will lead to opener falling causing serious personal and /or property damage.

Note: A set of fixing straps should be located in the centre of the aluminium rail to prevent rail flex that will result in phantom reversing.

Shuttle Stop

- 3.1) Fit the shuttle stop to the track at the power head end by inserting the stop assembly into the track and tightening the bolts. Do not overtighten. (Fig 8)

This will prevent the door from contacting the motor when operated manually. Warranty will be void if motor is damaged due to stop not being fitted.

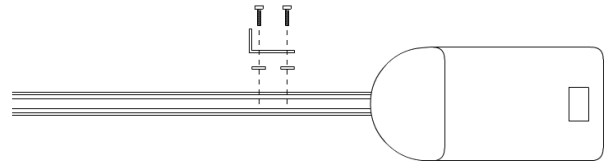
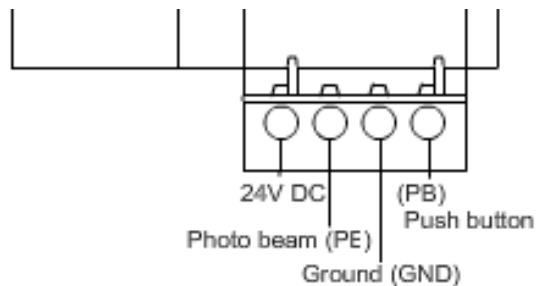

Fig. 8

Terminals and Connections



- 1) GND & PB: Step by step command input (open stop close) same as the step by step button on the transmitter. = **Push Button** terminal
- 2) GND & PE = **Photo Beam** terminal.
- 3) 24V & GND & PB = **Plug in receiver** terminal.

To safeguard the opener and avoid damaging components while wiring disconnect the unit from all power when working on it.

Remember that there are specific, strict standards that must be complied with in regard to both the safety of the electrical systems and automatic doors.



Only qualified, trained personnel may carry out the installation and subsequent maintenance in compliance with Australian standards.

Whoever installs and uses the Smart Lifter sectional door opener will be held responsible for any damage caused.

NOTE: Contact Smart Openers technical department for the wiring diagram for the above connections if uncertain of the correct procedure.

Programming the Unit

The system must be checked and tested when connections are completed.

- 4.1) Check that the chain support is halfway so that movement is problem free both in opening and closing.
Make sure that all the standards relative to the automatic gates and doors category have been observed.
- 4.2) Now carry out a test with the door disconnected from the motor and open and close the door to verify that the mechanical parts are all in good working order and the door does not bind or jamb in its tracks.
- 4.3) Power the unit. As soon as the unit is powered the system displays a 7-segment LED number from 0-9, and the lamp will turn on for 2 seconds.

If the LED display is upside-down, press the SET button once, then the LED will display the number in the correct direction. The system will remember the display direction. It will display correctly next time the power is turned back on.

If this is not the case, switch the power off immediately and check connections carefully.

- 4.4) Check that all the safety devices on the unit are working properly (emergency stop, photo beam, etc.). This is one of the most important checks and must be done with great care; in fact, the active safety of the automatic door depends on the correct functioning of the safety devices. The reversing sensitivity device is of great help in minimising damage but only the correct installation of the safety devices will make it possible to stop the door before it can cause any damage or injury to person and/or property.
- 4.5) It is now time to set the opening and closed position.

Setting Open and Close Positions

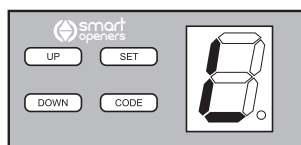

LIMITS SET MODE

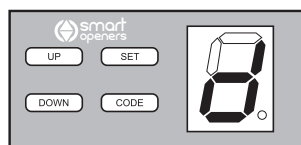

LIMITS SET DOWN

- 5.1) Press and hold UP until the LED displays the letter **L** release UP.
- 5.2) Now press UP again and hold, the door will travel to the open position, release the button when the door has reached the desired position.
- 5.3) If the door has overrun its position, press DOWN to move the door downwards. Adjust and fine tune the position by pressing UP and DOWN.
- 5.4) Press SET to set the open position the LED will display the letter **d** it is now time to set the closed position.
- 5.5) Press and hold DOWN, the door will travel to the close position release DOWN when the door has reach the closed position.
- 5.6) If the door has overrun its position, press the UP to move the door upwards. Adjust and fine tune the position by pressing DOWN and UP.
- 5.7) Press the SET to confirm.

The door will now open and close automatically to map the open and close sensitivity force requirements.

WARNING: Keep all persons and property clear of door during the installation process.

- 5.8) The door is now set for normal operational mode.

IMPORTANT: Safety systems must be checked regularly to ensure that maximum safety is maintained at all times.

Note: If you are not happy with the limits setting. Go back to Step 5.1 to set new limits.

Force Settings

Adjustments

Normally, the force settings are automatically set and adjustment is not necessary. However, the force can be adjusted by an authorized smart opener's installer for special purposes if necessary.

- 6.1) Press DOWN and hold, the LED will display a setting number from 1 to 9, release DOWN, it is now in force adjustment mode.
- 6.2) Press UP to increase the force one-degree and press DOWN to decrease one degree maximum degree is 9 and the minimum is 1.
- 6.3) Press SET to confirm.

Function Modes

The Smart Lifter has two selectable functioning modes: PHOTO BEAM and AUTO-CLOSE. Photo Beam mode should only be activated when a photo beam is connected. The opener will not function correctly if a photo beam is not connected.

Note: For safety Auto-Close should only be activated when a photo beam is installed.

7.1) SET PHOTO BEAM

Make sure the photo beam has been installed correctly before setting the PHOTO BEAM function.

- 7.1.1) Press and hold DOWN and SET until the LED displays **—**.
- 7.1.2) Press DOWN once, the LED displays **H**, the photo beam is now enabled.
- 7.1.3) Press SET to confirm.

To disable photo beam enter function mode set as above. Press DOWN so that the LED displays **||**. Press SET to confirm.

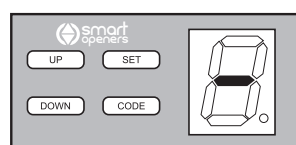

FUNCTION MODE SET

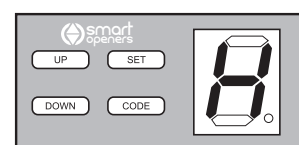

PHOTO BEAM ACTIVE

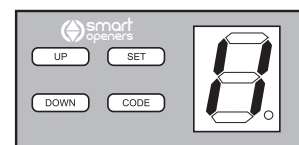
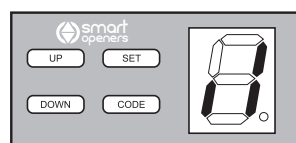

PHOTO BEAM DISABLED

7.2) SET AUTO-CLOSE

- 7.2.1) Press and hold DOWN and SET until the LED displays **—**.
- 7.2.2) Press UP once, a full vertical line on right and half-vertical line on the left will be displayed **||**, auto-close is enabled. See 7.2.3 to set time delay.
- 7.2.3) Press DOWN once, to increase the auto close time by 1-minute increments from 1 – 9, once you get to 9 it will go back to 1.
- 7.2.4) LED displays the current set value.
- 7.3.3) Press SET to confirm.

To disable Auto-Close enter mode set as above. Press UP once, a full vertical line on the left and a half-vertical line on the right will be displayed (**||**), auto-close has been disabled. Press SET to confirm.



AUTO-CLOSE ACTIVE

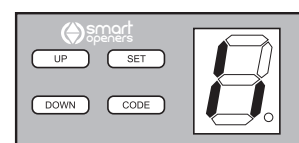

AUTO-CLOSE DISABLED

Coding Transmitters

Note: This Smart Lifter opener is supplied with the transmitters already coded (depending on country). Please test all transmitters to confirm that they are coded prior to starting Step 8.1.

- 8.1) Press CODE until the LED displays (■). Press a button on the transmitter, the LED dot will turn off. Release and press the same button again, the dot will flash to confirm the code.
- 8.2) Repeat step 8.1 to code a maximum of 20 different transmitters and/or buttons.
- 8.3) To delete all stored codes, press and hold CODE for 8 seconds until LED dot turns off, all stored codes have now been deleted.

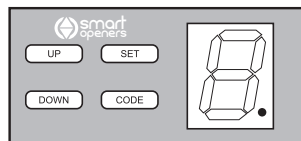

TX CODE ACTIVE

Maintenance

No particular maintenance is required for the logic circuit board.

At least twice a year check that the door is properly balanced and that all working parts are in good working condition.

IMPORTANT: A poorly operating door can effect the life of the automatic opener due to incorrect loads and will void the warranty.

Check the reversing sensitivity at least twice a year and adjust if necessary.

Make sure that the safety devices are working effectively (photo beams, etc.)

Final Notes

This manual is only for use by technical personnel qualified to carry out the installation.

No information given in this manual can be considered of any interest to the end user.

No setting or adjustments contained in this manual should be carried out by the end user.

It is important for the installer to show their clients correct operational use of the Smart Lifter including the use of the manual disengagement cord.

Inform the owner about the need for regular and accurate maintenance, especially regarding a regular check of the safety and reversing devices.

Technical Specifications

Power Input:	240 VAC ±10% 50Hz
Motor:	24V DC 100W
Courtesy light time:	3 mins
Working temperature:	-20° ~ 70°C
Relative Humidity:	<90%
Open and close force:	600N
Reception frequency:	433.22MHz
Sensitivity:	>1V for correct receiver signal (average range 50m, with an aerial)
Decoding:	Rolling code
Transmitter power:	23A 12V Battery
Globe:	24V 21W Automotive type (available from most car accessories stockists)

NOTE: Smart Openers Pty Ltd reserves the right to modify its product and product specifications at any time without prior notice.

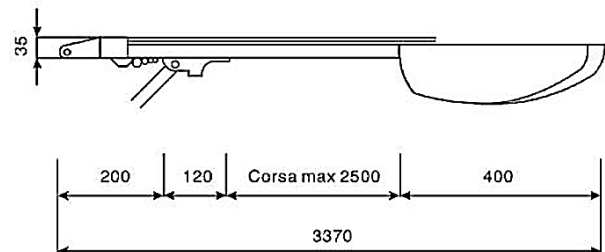

Typical Application

The Smart Lifter (max. 2500mm travel) model can automate sectional overhead doors up to a height of 2600mm and tilting overhead doors up to 2600mm.

Manual Disengagement

The Smart Lifter is equipped with a manual release cord to disengage shuttle and move door by hand while holding the handle down (Fig. 9). To operate pull on the handle to disengage the shuttle. To re-engage the door simply run opener in automatic mode or move door by hand until the trolley engages in the chain shuttle.

For situations where a pedestrian door is not present it is recommended that an external disengagement device is fitted. (Fig. 10).

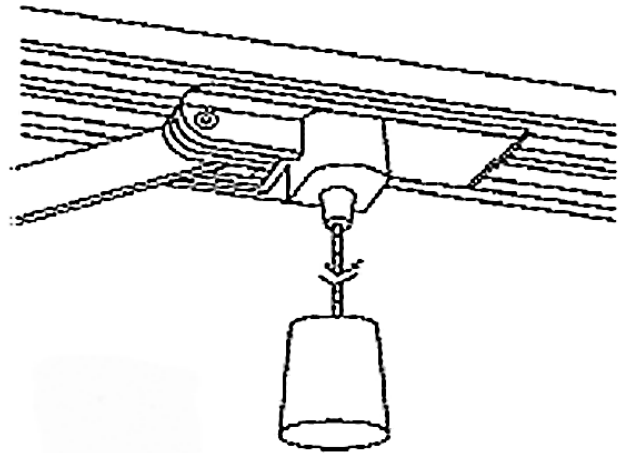

Fig. 9

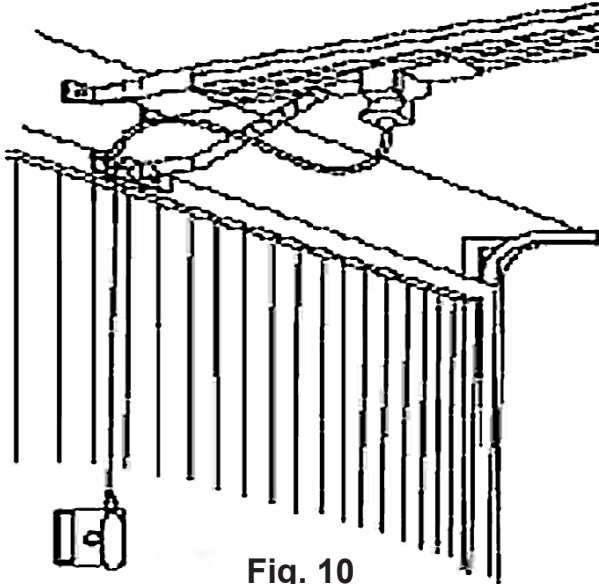

Fig. 10

Important Information for the User

Once the Smart Lifter opener has been installed, the user must be informed about how it works and all the risks that can arise if it is used improperly. The user must avoid placing himself/herself in dangerous situations such as standing within the door's operating range when it is moving.

Do not let children play near the door and keep the remote controls out of their reach.

All servicing, repairs or checks must be carried out by professionally qualified personnel and noted on a maintenance register kept by the user.

Information for the user is found in the USERS/OWNERS MANUAL included with this opener.

IMPORTANT: Please make sure the USERS/OWNERS MANUAL is passed on to the owner prior to leaving the installation.

IMPORTANT: In the case of a malfunction the user must call an authorized smart opener Pty Ltd installer and should not attempt to repair it.

Warranty and Exclusion of Liability

1. This warranty is an addition to any conditions or warranties that are implied by relevant statute, including the Trade Practices Act 1974 (Cth), which cannot be excluded or negated.
2. Subject to all of the matters set out below, **Smart Openers Pty Ltd** ("**Smart Openers**") warrants:
 - (a) swing and sliding gate opener drive units for twelve (12) months
 - (b) roll-up and overhead door opener drive units for twenty four (24) months
 - (c) all components and accessories for twelve (12) months, from the date of purchase (specified in the sales docket receipt) as free of any defects in material and workmanship.
3. This warranty applies only where the purchaser:
 - (a) immediately notifies **Smart Openers** or the retailer of the alleged defect;
 - (b) returns the product to **Smart Openers** or the retailer; and
 - (c) presents the relevant sales docket and this warranty document to the retailer and, if so requires, to **Smart Openers** to confirm the date of purchase.
4. Defects or damage partly or wholly due to any of the following causes are not covered by this warranty:
 - (a) accidental damage to any of the Product or to the Product's components;
 - (b) normal wear and tear to the Product or to the Product's components;
 - (c) flood, rain, water, fire, lightning, storms, any acts of God, contamination or pollution;
 - (d) incorrect, improper, inappropriate or unreasonable maintenance and/or use;
 - (e) installation, adjustment or use which is not in accordance with the instructions set out in installation instructions incorporated in the document;
 - (f) attempted or complete modification or repairs to the Product or tampering with the Product carried out by a person who is not authorised by **Smart Openers** to carry out such modification or repairs;
 - (g) faulty or unsuitable wiring of structure to which the Product is fixed or connected;
 - (h) radio (including citizen band transmission) or any electronic interference;
 - (i) blown fuses or damage caused by electrical surges, power surges or power spikes;
 - (j) damage caused by insects or any infestation;
 - (k) negligence or deliberate damage.
5. Except for this warranty, **Smart Openers** gives no warranties of any kind whatsoever (whether express or implied), in relation to the product, and all warranties of whatsoever kind relating to the product are, to the extent permissible by statute, hereby excluded and negated.
6. To the extent permissible by statute, **Smart Openers** disclaims any liability of whatsoever nature in respect of any claim or demand for loss or damage which arises out of:
 - (a) accidental or deliberate damage to, or normal wear and tear to, the product or to the product's components;
 - (b) any cost relating to damage resulting from wear and tear;
 - (c) blown fuses, loss or damage caused by electrical surges, power surges or power spikes;
 - (d) loss or damage due to theft, fire, flood, rain, water, lightning, storms, any acts of God, contamination or pollution;
 - (e) door or gate not in safe and correct working order and condition;
 - (f) evidence of unauthorised repairs;
 - (g) any cost relating to damage caused deliberately or by misuse, negligence or failure to maintain the equipment in a proper working order, including (without limitation) due to anything described in paragraphs (d) and (e);
 - (h) installation, adjustment or use which is not in accordance with the instructions set out in installation instruction manual and owners manual;
 - (i) attempted or complete modification or repairs to the Product or tampering with the Product carried out by a person who is not authorised or has not been trained by **Smart Openers** to carry out such modification or repairs;
 - (j) faulty or unsuitable wiring of structure to which the Product is fixed or connected;
 - (k) radio (including citizen band transmission) or any electrical interference;
 - (l) damage caused by insects or any infestation;
 - (m) loss or damage to any property whatsoever or any loss, damage or expense whatsoever resulting or arising therefrom;
 - (n) any consequential, indirect, special or incidental loss or damage;
 - (o) any cost or expense arising due to manufacturer recall of any product;
 - (p) any cost or expense due to negligence of the approved service provider;
 - (q) installation of a residential garage door or gate opener in a commercial or industrial situation or a non-single residential dwelling.
7. **Smart Openers** liability under this warranty is limited, at **Smart Openers** absolute option, to replacing or repairing the product which **Smart Openers**, in its unfettered and absolute opinion, considers to be defective either in material and/or workmanship or to credit the dealer with the price at which the product was purchased by the dealer.
8. This warranty does not extend to cover labour for installation.
9. This warranty is limited to Return-to-Base (RTB) repair and does not cover labour for on-site attendance.
10. This warranty is void if the Product is not returned to the manufacturer in original or suitably secure packaging.
11. This warranty is only applicable for repairs to the Product carried out within Australia and for Product in Australia.
12. This warranty does not cover consumable items including globes, batteries and fuses.
13. This warranty is not transferable.
14. Where the Product is retailed by any person other than **Smart Openers**, except for the warranty set out above, such person has no authority from **Smart Openers** to given any warranty or guarantee on **Smart Openers** behalf in addition to the warranty set out above.

Notes:

1. This warranty is to be read in conjunction with the installation manual and owner's manual.

Smart Openers Pty Ltd

PO Box 6666 GCMC, Qld 9726

Tel: 1300 366 547 Fax: 1300 366 972

Email: enquiries@smartopeners.com

Web: www.smartopeners.com

© October 2009 Smart Openers Pty Ltd. All rights reserved. In an ongoing commitment to product quality and innovation smart openers reserves the right to change and alter specifications and model numbers and types without notice

D/N: SLIM141009