

Smart Roller Nano

Roll Up Door Opener

The Nano is like a Merlin set up | Hold the SET button in for a few seconds to start and then follow what it says on the screen

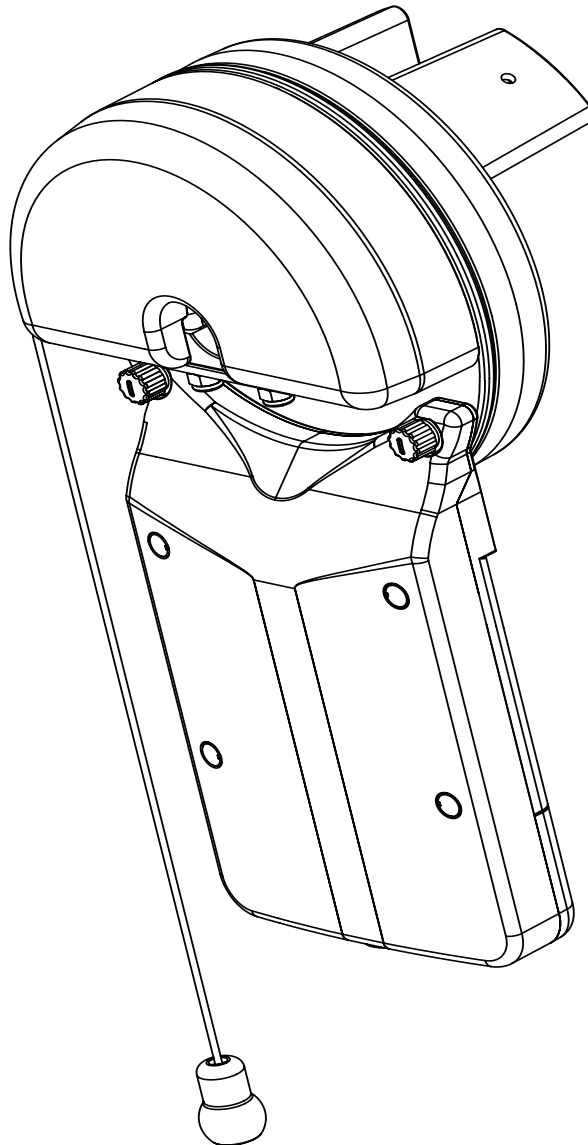

WARNING: IT IS VITAL FOR THE SAFETY OF ALL PERSONS INSTALLING AND USING THIS OPENER TO FOLLOW THE INSTALLATION INSTRUCTIONS AND SAFETY WARNINGS. FAILURE TO COMPLY MAY RESULT IN SERIOUS PERSONAL INJURY AND/OR PROPERTY DAMAGE AND FAILURE OF THE OPENER SYSTEM.

INSTALLATION MANUAL

Index

KIT CONTENTS	3
IMPORTANT SAFETY WARNINGS	3
DESCRIPTION	3
OPERATING CONTROLS	4
BEFORE INSTALLATION	5
SIDE ROOM REQUIREMENTS	6
FIXING WEIGHT BARS	6
FIXING DOOR CURTAIN	6
MANUAL RELEASE	6
MOUNTING DRIVE UNIT	7
TIGHT SIDE ROOM OPTION	8
RISK OF ENTRAPMENT LABEL	8
POWERING UP	8
MENU NAVIGATION	8
CODING TRANSMITTERS	9
DELETING TRANSMITTERS	9
VACATION MODE	9
LIMITS SET UP VIA CONTROLLER	10
LIMITS SET UP VIA TRANSMITTER	11
OBSTRUCTION FORCE MARGIN	12
MOTOR OPEN/CLOSE SPEED	12
PE BEAM MODE	13
AUTO-CLOSE MODE	13
AUTO-CLOSE TIME DELAY	13
PE-CLOSE MODE	13
HANDS FREE LEARNING	14
TRANSMITTER BUTTON ALLOCATION	14
TESTING OBSTRUCTION FORCE MARGIN	14
INFORMATION FOR THE USER	15
MAINTENANCE	15
FINAL NOTES	15
TECHNICAL SPECIFICATIONS	15
WARRANTY	16

To the extent that they may be lawfully excluded, Smart Openers Pty Ltd hereby expressly excludes all conditions and warranties, statutory or otherwise, which may be implied by law as conditions or warranties of purchase of a Smart Openers Pty Ltd Garage Door Opener. Smart Openers Pty Ltd hereby further disclaims and rejects to the maximum extent permitted by law any liability or responsibility whatsoever for any direct, indirect, consequential, incidental or other injury, damage, cost, expense or loss whatsoever incurred or suffered by any person, company, firm or organization as a result of any failure to install the Garage Door Opener in accordance with these installation instructions.

No part of this publication may be reproduced, utilised, transmitted, or distributed in any form by any means including photocopying, recording, mechanical, electronic or otherwise by any party, without the written permission from the publisher Smart Openers Pty Ltd. Copying without authorisation is ILLEGAL.

© February 2009 Smart Openers Pty Ltd. All rights reserved.



Contents

Part		
No	Description	Qty
1	Motor	1 Set
2	Transmitter	2 Pcs
3	Installation Manual	1 Pc
4	Owners manual	1 Pc
5	Quick Start Guide	1 Pc
6	Risk of Entrapment Label	1 Pc
7	Weight Bar (Optional)	1 Pc
8	Coning Collar (Optional)	1 Pc

Important Safety Warnings

The Smart Roller Nano garage door opener described in this manual is designed for the automation of residential roll up doors to a maximum size of 16m² that are properly balanced and operating smoothly. Any other use is considered improper and will void the warranty.

WARNING:

You are carrying out operations on machine systems classified in the automatic gates and doors category and as such failure to comply with the relevant safety rules may result in serious personal injury and/or property damage. Reference to the safety rules can be found on pages 2-4 of the owners manual and should be read and understood prior to installation.

Only qualified personnel should install and service the equipment. It is the responsibility of the installer to adhere to all relevant safety standards.

The Smart Roller Nano opener is designed and manufactured to meet all current Australian standards and it is essential that the installer also installs the

equipment in accordance with all local and Australian regulations.

Unqualified personnel or those who do not know the occupational health and safety standards applicable to the automatic gates and doors category must under no circumstances carry out installations or implement systems.

Persons who install or service the equipment without observing all the applicable safety standards will be held responsible for any damage, injury, cost, expense or claim whatsoever suffered by any person as a result whether directly or indirectly from failure to install the system correctly and in accordance with the relevant safety standards and installation manual.

For a more detailed list of the Safety Warnings and Safety Issues associated with the installation and use of a Smart Roller Nano roll up door opener refer to the safety warnings in the OWNERS MANUAL.

Description

The Smart Roller Nano garage door opener requires a 240VAC 50Hz power input and has a 24V DC motor and can provide remote control and automatic modes for operation. When the door is in operation, movement can be interrupted by activation of the safety inputs: transmitter, wall button (if fitted) and photo beams (if fitted).

Limits set open and close positions and braking during the end of the travel cycle reducing speed and noise.

A 433.22MHz radio receiver is built into the circuit board and the rolling code is memorised via the self-learning technique. As an alternative to the built-in receiver the opener will accept any of the range of stand alone radio receivers. The opener has been designed to provide maximum reliability, safety and flexibility of use.

IMPORTANT:

Before commencing installation please read all of the instructions carefully and make sure you are familiar with the safety warnings included in this manual and in the OWNERS MANUAL.

Operating Controls

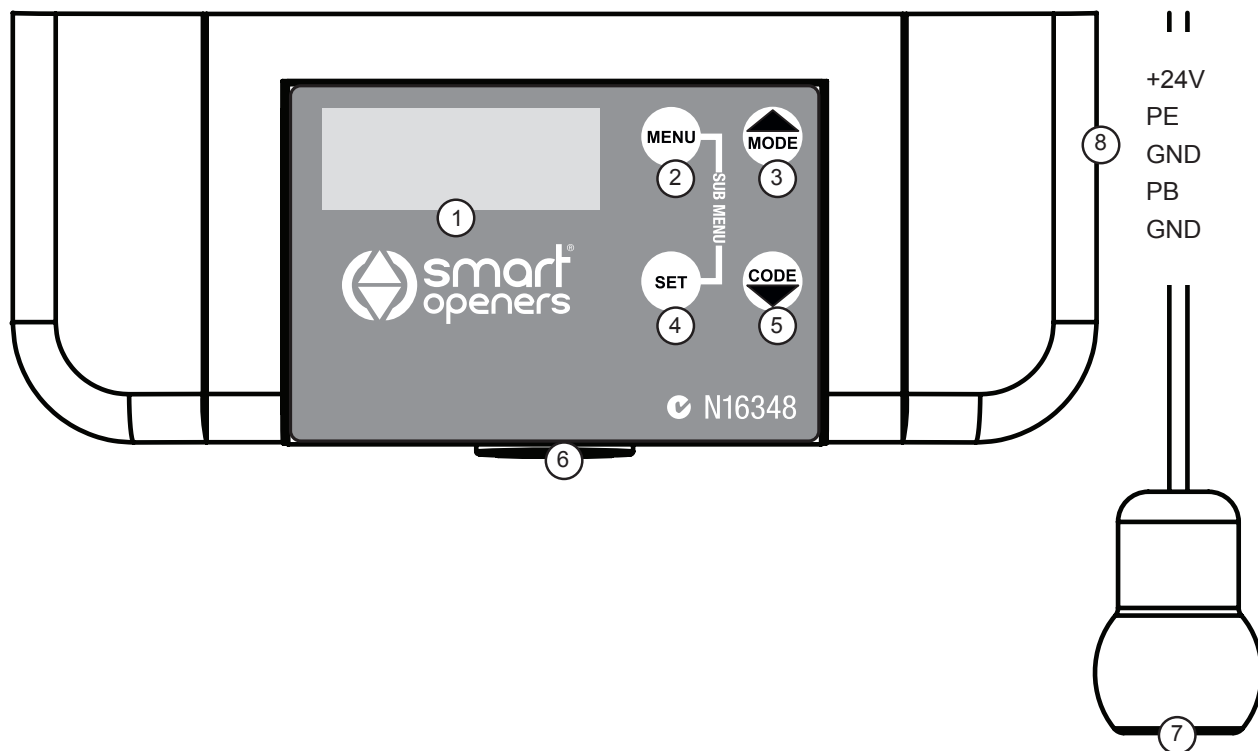

- 1 **LCD Display** - displays operating parameters and functions.
- 2 **MENU Button** - used to access set up menu and to change parameter settings.
- 3 **MODE Button** - used to save settings and exit to normal operation.
- 4 **SET Button** - used to save settings changes and move to next parameter.
- 5 **CODE Button** - used to store transmitter code.

- 6 **PB (Push Button)** - used to operate the door. (open/stop/close)
- 7 **Manual Release Cord** - used to engage/disengage the door for automatic/manual operation.
- 8 **Input Terminal Block** - used for connecting photo electric safety beam or external push button trigger.

Before Installation

1. Read the instructions carefully.
2. Make sure the door structure is solid and suitable to be motor driven.
3. Make sure that when the door is moving there are no friction points.
4. The door must be properly balanced and must be easily lowered and raised by hand.
5. A 240V, adequately protected 3-pin power outlet must be near where the Smart Roller Nano opener is going to be installed.

Remember there are specific standards that have to be strictly followed regarding the safety of electrical installations for automatic gates and doors.

As well as the legal requirements and standards that must be adhered to, please take note of the following points to ensure maximum safety and reliability of your installation.

6. Prior to installing check the surrounding environment. Carefully evaluate any hazards there could be from physical damage (transiting vehicles, parts of trees falling etc.), possible contact with foreign bodies (insects, leaves, etc.), flooding hazards or any others exceptional events.
7. Check that the main voltage is the same as that given on the rating plate and in this manual.
8. Check there is suitable electrical protection against short circuits/power spikes and proper earthing on the mains supply.

Remember the unit has mains voltage running through it (electrocution hazard, fire hazard).

9. Take care with the opener; parts may be subject to damage if abused.

10. Make sure you have all the necessary installation materials and that they are suitable for this kind of use.
11. Read all the instructions thoroughly and make sure they are understood before attempting to install the Smart Roller Nano.
12. Before starting the installation, carefully analyse all the risks relating to automating the door. Verify that the door to be automated is in a sound condition and that the mechanisms are in good working order; observe the safety margins and minimum clearances.
13. Evaluate with particular care the safety devices to be installed and where to install them; always install an emergency stop device for interruption of power to the opener if required.
14. Once the risks have been analysed, install the Smart Roller Nano opener and relative safety devices, emergency stop and/or photo electric cells.

Important: For additional safety Smart Openers Pty Ltd strongly recommends the fitting of photo electric safety beams on all installations.

15. When installing the Smart Roller Nano opener, strictly follow all the instructions given in the instruction manual. If some points or procedures in this manual are not very clear do not install the unit until all doubts have been cleared up with our technical department.

IMPORTANT NOTICE

This opener is not designed to accept extension fingers to engage recessed curtain drum wheel spokes as has been done in competitor's openers for the past ten years or so. The forks in the Smart Roller Nano opener are not designed to accept any such extension fingers and the fitting of extension fingers is not necessary. The lengths of the forks of this opener are slightly longer than those used in competitors openers in any event.

Before Installation

Side Room

The minimum sideroom required is just 20mm between the edge of the door curtain and wall bracket with a total of 70mm from the wall to the edge of the door curtain (Fig. 1). If the situation permits, it is recommended that 80mm is allowed between door curtain and bracket and a total of 130mm between the door curtain and the wall (see Fig. 2).

Fixing The Weight Bar

In most cases a weight bar may not be required unless the door curtain is very light or is quite small and may be prone to ballooning/barrelling.

If so, position the weight bar so that it is centrally spaced along the bottom rail of the door. Secure with fasteners provided and test operation. If the door feels heavy or does not remain stationary when open half way, extra tension may need to be added to the door springs. Refer to the door manufacturer's instructions for proper adjustment procedure.

Fixing The Door Curtain To Drum Wheel

The door curtain has to be secured to the drum wheel with suitable fasteners.

- (a) With the door in the fully closed position mark the curtain on both ends of the door.
- (b) Open the door slightly to access the marked positions. Secure the curtain to drum wheel using self drilling screws (two on each end). The screws should be at least 90 degrees apart as per Fig. 4.

Manual Release

- 1 To disengage door for manual operation, pull the red cord with minimum pressure then release. You should now be able to move the door either up or down by hand. Remember, excessive force on the cord may result in damage to the opener.
- 2 To re-engage door for automatic operation repeat the same action. Pull the red cord again and the door should now be in automatic operation.

IMPORTANT: If the only entry to the garage is via the garage door, Smart Openers strongly recommend the fitting of an external key release device.

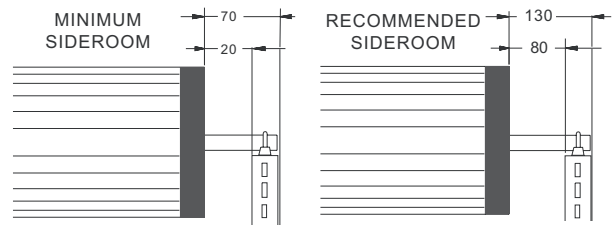

Fig. 1

Fig. 2

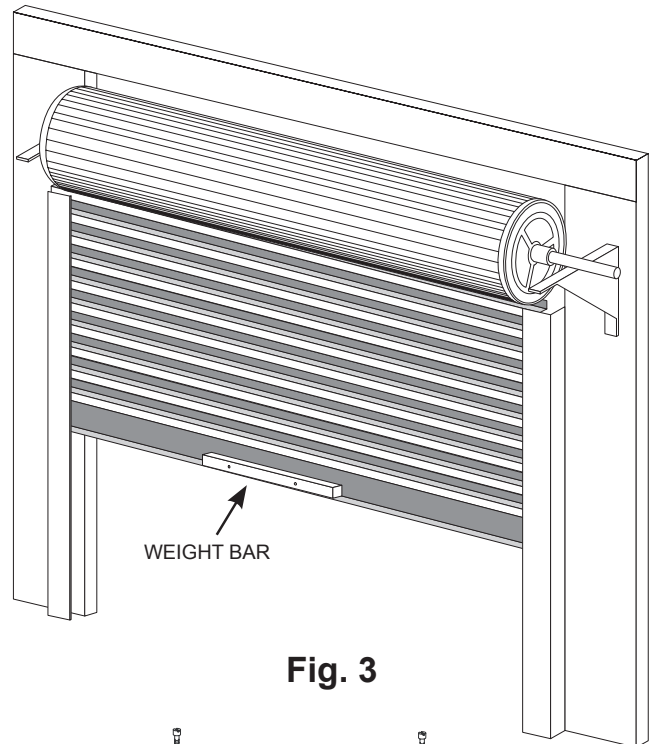

Fig. 3

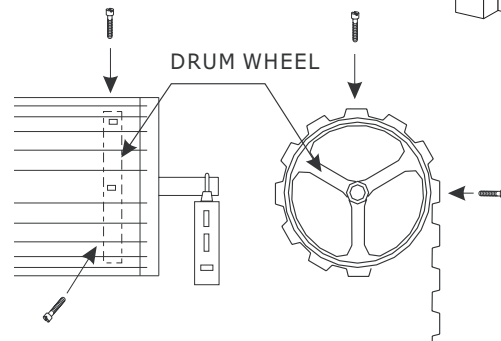

Fig. 4

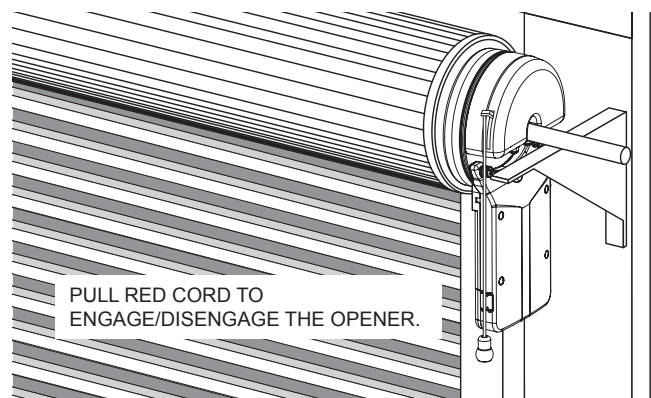

Fig. 5

Installation

Fitting Drive Unit to Door

Note: The following instructions are for **RIGHT HAND SIDE** installation (from the inside looking out).

- 1 Check that the U-Bolt on the opposite end (left hand end) of the door shaft is securely tightened.
- 2 Roll the entire door curtain onto the drum and tie securely with rope (or similar).
- 3 Using a suitable prop support the right side of the door. Make sure that the prop is padded to avoid marking the curtain.

WARNING: CREATE A BARRIER AROUND THE WORK ZONE TO PROTECT PERSONS FROM INJURY. DO NOT ALLOW CHILDREN/PERSONS AROUND THE DOOR WHEN PROPPED. SERIOUS PERSONAL INJURY AND/OR PROPERTY DAMAGE CAN RESULT FROM FAILURE TO FOLLOW THIS WARNING.

- 4 Carefully loosen and remove the right hand U-Bolt.
- 5 Make sure that the door is safely supported by the prop. Remove the right hand door bracket from the wall.
- 6 Hold the drive unit assembly and try to rotate the drive gear by pushing the fork. If it does not turn, switch the opener into manual mode by pulling the red cord downwards.
- 7 Slide the drive unit over the door shaft and make sure that the fork engages one of the spokes of the door drum wheel (Fig. 6).

Note: In limited sideroom situations the opener can rest on the door bracket. In this case you do not need to use the U-Bolt that secured the door just the one on the opener.

- 8 Refit the door bracket to the wall. In some cases it may need to be repositioned to accommodate the opener.
- 9 Refit the axle U-Bolt and tighten securely.
- 10 Straighten the drive unit and secure the motor drive unit U-Bolt.
- 11 Remove prop and test manual operation of the door. It should travel smoothly and not catch on the drive unit.

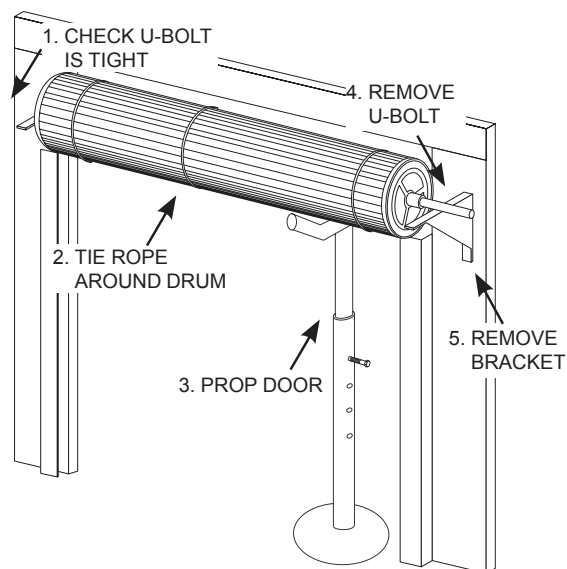

Fig. 5

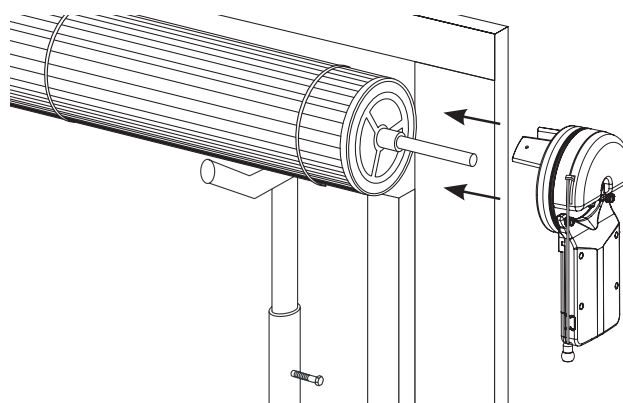

Fig. 6

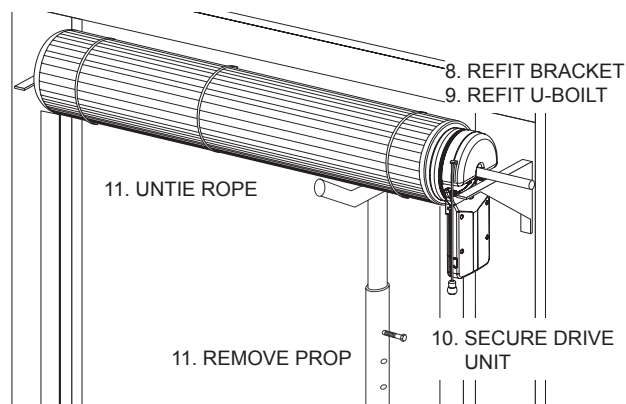

Fig. 7

Tight Side Room Option

In situations where sideroom is very restricted and installing the opener in one piece is difficult, the control box module can be separated from the drive motor by unscrewing the thumb screws (Fig. 8).

If refitting the control box module after installation is still difficult you can mount the controller on the wall with optional wall mount bracket and extension cable (Fig. 9). When using the wall mount bracket fix the control panel with thumb screws and connect the extension cable between the controller module and the drive motor.

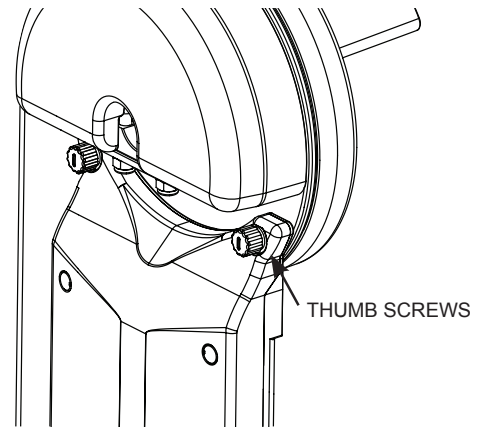
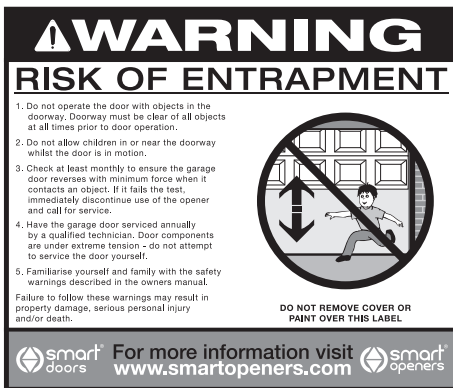

Fig. 8

Risk Of Entrapment Label

- 1 The warning risk of entrapment label must be attached to the door in a suitable, prominent location so as to inform all users of the dangers involved in owning and operating an automated garage door. We provide this label for everyone's safety and it only takes seconds to install. So as a responsible garage door installer please make sure this is completed before leaving the job. **THE FITTING OF THIS LABEL IS MANDATORY.**



- 2 Once set up is complete and the obstruction margin test is carried out (see page 14), please ensure that this warning and all safety warnings described in the owners manual are explained to the user to ensure that they are clearly understood and followed.

Powering Up

- 1 Inspect the power cable for damage. Ensure that the cable will not interfere with the moving door or the opener.
- 2 Connect to power. The opener will perform a firmware check and display the welcome screen with firmware version for 2 secs as per Fig. 10 followed by the firmware release date for 2 secs as per Fig. 11. The first time the unit is powered up and no limits have been set the unit will display Positions Not Set (Fig. 12).

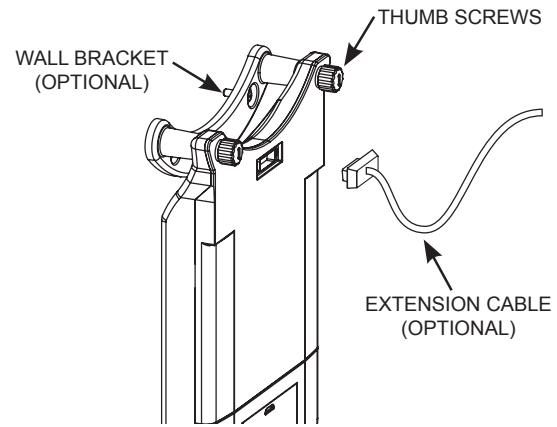

Fig. 9

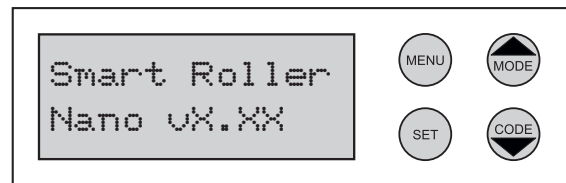

Fig. 10

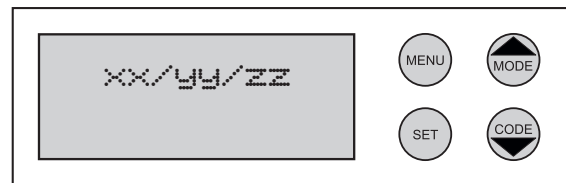

Fig. 11

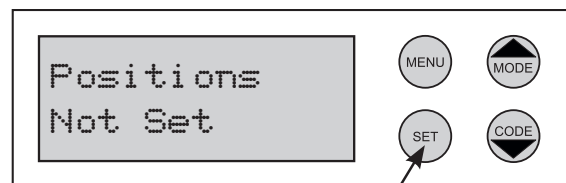

Fig. 12

Menu Navigation

- MENU Button** Enter parameter settings mode and change parameter settings.
- MODE Button** Save settings and exit set up mode and return to normal operation.
- SET Button** Save setting and move to next menu item.
- CODE Button** Learn transmitter code.

Coding Transmitters

Note: The button you choose (1-4) for the **first** TX you code will be the same button for all subsequent transmitters. Up to twenty TXs can be stored into memory. If more than twenty are stored the system will disregard any attempts to code new TXs.

- 1 Press the **CODE** button for 2 seconds the display will show Code Learn (Fig. 13).
- 2 Choose which transmitter button will operate the door and press that button twice.

The first press will allocate a number to the remote and the display will show Remote XX (Fig. 14), on the second press the display will show CODE SET (Fig. 15). The transmitter has now been coded and the security code stored in the memory on board. Test the transmitter - the opener will beep to confirm.

Repeat the above steps to code additional transmitters.

REMOTE TRANSMITTER CODING

It is possible to code new transmitters via an already coded remote without being in contact with the control panel. This is useful if more than one device is operated by the transmitter. This also takes the guess work out of button allocation as this is done automatically.

- 1 Ensure Hands Free Learning is enabled (page 14).
- 2 Press **TX BUTTON 3 + 4** together for 2 seconds. The opener will beep and light will flash once to signal Code Learn Mode.
- 3 Press any button on new transmitter twice (Fig. 16). The opener will beep and light will flash twice to confirm code learned. Test new transmitter.

DELETING ONE TRANSMITTER

You can delete one specific transmitter without clearing the entire memory of the opener or having the transmitter on hand. This is useful if the transmitter is lost or stolen and the transmitters reference number is known.

- 1 Press and hold the **CODE** button for 5 seconds.
- 2 The display will show Del Remote XX (Fig. 17).
- 3 Press **MODE** button to scroll to required transmitter number.
- 4 Press **CODE** for 3 secs to delete.

DELETING ALL TRANSMITTERS

- 1 Press and hold the **CODE** button for 5 seconds.
- 2 Press **MODE** button to scroll through until the display shows Del Remote ALL.
- 3 Press **CODE** for 3 secs to delete.

ACTIVATING VACATION MODE

This is useful for locking out operation while away from the property for prolonged periods.

- 1 Press and hold the **MENU** button for 10 seconds.
- 2 If the door is open it will allow a final close cycle only and remain closed until vacation mode is disabled.

DISABLING VACATION MODE

- 1 Press and hold the **MENU** button for 10 secs or press transmitter buttons 1 + 2 together for 10 secs. (Fig. 19).

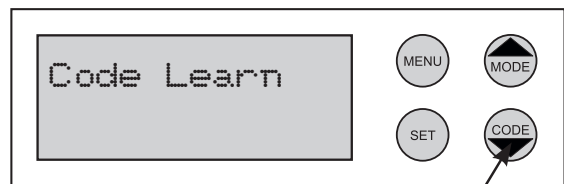

Fig. 13

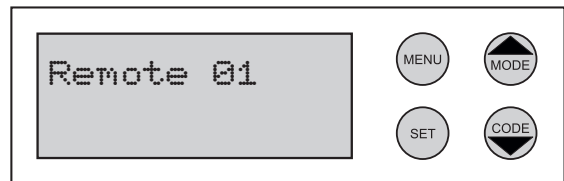

Fig. 14

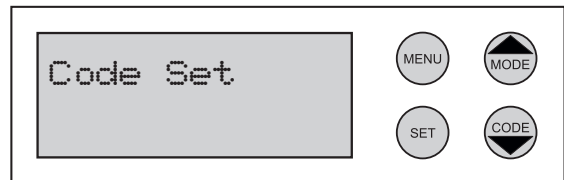

Fig. 15

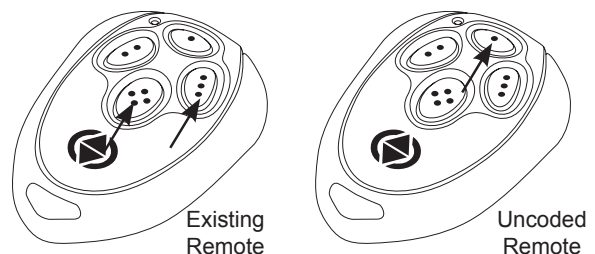

Fig. 16

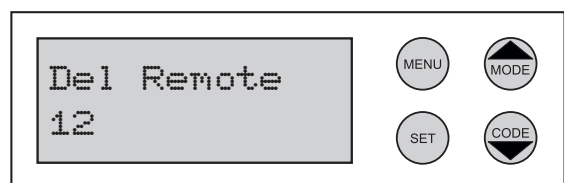

Fig. 17

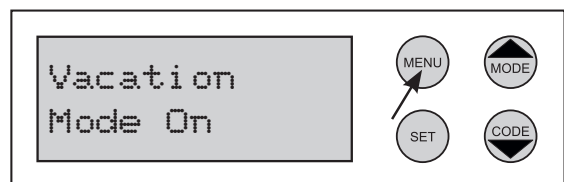

Fig. 18



Fig. 19

Left or Right Hand Installation

The opener is shipped from the factory ready for installation on the **RIGHT SIDE** of the door (when viewed from inside the garage). If installing on the **LEFT SIDE** then ensure you specify the correct orientation in the next step.

- 1 Press **SET** for 3 secs to enter set up. The display will show `Right Hand Installation` (default). If this is correct press **SET** to confirm.
- 2 To change to `Left Hand Installation`, press **MENU** then press **SET** to confirm (Fig. 20).

The opener will now go to limits set up.

Setting Limits Via Controller

- 1 With the door open approximately half way, make sure that the drive motor is engaged. The display will show `Set Open Position` (Fig. 21).

Note: If the door starts closing instead of opening the opener needs to be reset to the correct side (Left/Right). Press **MENU** to abort limits set up and repeat initialising procedure as per above.

- 2 Press and hold **MODE** to move the door (at half speed) to the desired **open** position and release. If you over shoot the desired position press **CODE** and drive the door down at least 100mm. Then press **MODE** again to drive the door up.
- 3 Press **SET** to confirm. The display will show `Open Position Set` for 2 secs then will show `Set Close Position`.
- 4 Press and hold **CODE** to move the door (at half speed) to the desired **closed** position. If you over shoot the desired position press **MODE** and drive the door up at least 100mm. Then press **CODE** again to drive the door down.
- 5 Press **SET** to confirm. The display will show `Close Position Set` for 2 secs.
- 6 The opener will now run through a full cycle to measure the force margin required to open and close. Then the display will show `Set Up Complete`.

The system will now exit set up mode and return to normal operation. The display will show `Door Closed` (Fig. 26). If no further settings or adjustments are required, the system is now ready to use.

Now that transmitters are coded and limits set, if the parameter settings do not need alteration from factory default then the door is now ready for normal use. If further set up is required refer to page 12 for parameter set up.

Resetting Limits

If you are not happy with the limits positions and you are still in the process of setting limits, press **MODE** to abort limits set up then press **SET** again for 3 secs and repeat initialising procedure as per above.

If limits set up and door force margin profile has been completed, to reposition limits press **SET** for 3 secs to reenter set up mode.

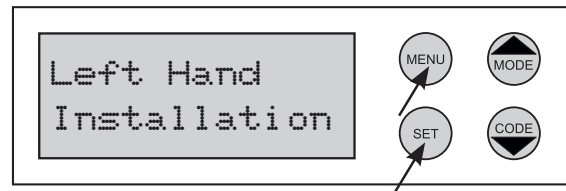

Fig. 20

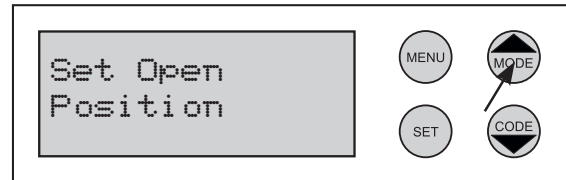

Fig. 21

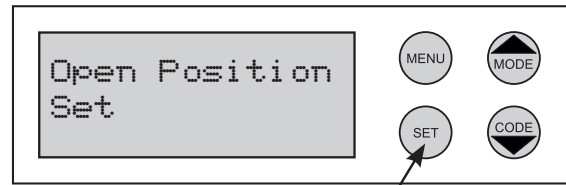

Fig. 22

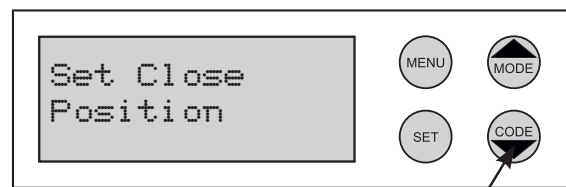

Fig. 23

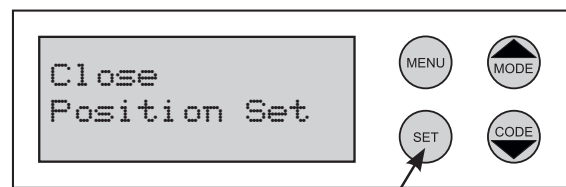

Fig. 24

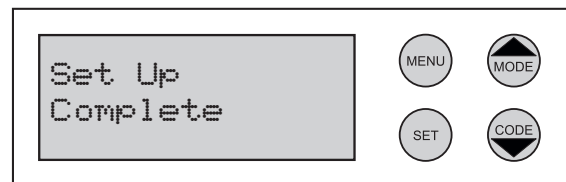

Fig. 25

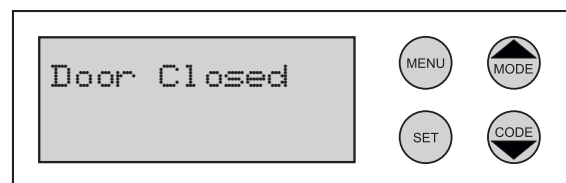

Fig. 26

Left or Right Hand Installation

The opener is shipped from the factory ready for installation on the **RIGHT SIDE** of the door (when viewed from inside the garage). If installing on the **LEFT SIDE** then ensure you specify the correct orientation in the next step.

- 1 Press **SET** for 3 secs to enter set up. The display will show **Right Hand Installation** (default). If this is correct press **SET** to confirm.
- 2 To change to **Left Hand Installation**, press **MENU** then press **SET** to confirm .

The opener will now go to limits set up.

Setting Limits Via Transmitter

- 1 With the door open approximately half way, make sure that the drive motor is engaged and the display shows **Set Open Position** (Fig. 27).

Note: If the door starts closing instead of opening the opener needs to be reset to the correct side (Left/ Right). Press **MENU** to abort limits set up and repeat initialising procedure as per above.

- 2 Press and hold **TX Button 1** to move the door to the desired open position. If you over shoot the desired position press Button 4 and drive the door down.
- 3 When desired open position is reached pause for 5 secs for opener to beep and lights to flash to indicate position set.
- 4 Press and hold **Button 4** to drive the door to the closed position. If you over shoot the desired position press Button 1 and drive the door up.
- 5 When desired closed position is reached pause 5 secs for opener to beep and lights to flash to indicate position set.
- 6 Use the remote to test travel limits.

If no further settings or adjustments are required, the system is now ready to use.

Now that transmitters are coded and limits set, if the parameter settings do not need alteration from factory default then the door is now ready for normal use. If further set up is required refer to page 12 for parameter set up.

Resetting Limits

If you are not happy with the limits positions and you are still in the process of setting limits, press **MODE** to abort limits set up and repeat procedure as per above.

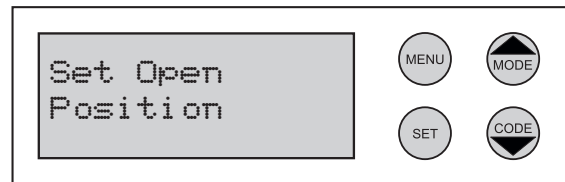

Fig. 27



Press & hold
Button 1 to
drive door up

Fig. 28



Pause for 5 secs
open limit will be
set automatically

Fig. 29

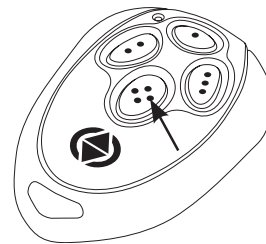

Press & hold
Button 4 to
drive door down

Fig. 30



Pause for 5 secs
close limit will be
set automatically

Fig. 31

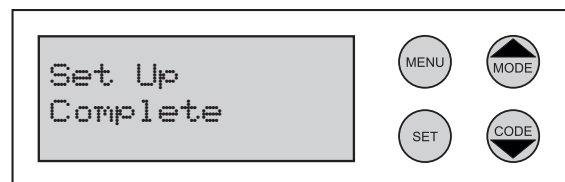

Fig. 32

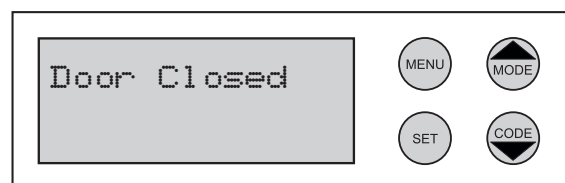

Fig. 33

Parameter Menu Settings

Factory default parameters are set and can be changed via the MENU SYSTEM.

NAVIGATION

MENU - Press for 3 secs to enter Menu System.
Press to change parameter setting.

SET - Save changes and cycle to next parameter.

CODE - Save changes and cycle to previous parameter.

MODE - Save changes and exit to normal operation.

To change settings press **MENU** to change parameter then **SET** to save change and move to next function.

Setting Obstruction Margin

The Obstruction Force Margin sensitivity is extremely important for user safety. Make sure that where possible the minimum (or default) force required to allow the door to travel without phantom reversing is used. Smart Openers strongly recommend that the door is properly serviced rather than increasing the force margin to compensate (Factory Default = 03).

- 1 Press **MENU** for 3 secs then press **SET** to cycle through to `Obstruction Setting`.
- 2 Press **MENU** to cycle through from 0 - 9.
- 3 Press **SET** to confirm or **MODE** to save and exit.

Setting Motor Open and Close Speeds

If required the opening and closing speed can be adjusted in 5% steps down to 50% to suit the site. If changing motor speed remember to reset travel limits and reprofile the door. (Factory Default = 80%).

- 1 Press **MENU** for 3 secs then press **SET** to cycle through to `Open Speed` or `Close Speed` as required (Fig. 35 & 36).
- 2 Press **MENU** to cycle through from 80% down to 50% in steps of 5%. Once 50% is reached the next press of the **MENU** button will return to 100%.
- 3 When desired speed percentage is reached press **SET** to confirm or **MODE** to save and exit.

Setting Photo Beam Mode

Note: A functioning photo electric safety beam must be installed and Photo Beam Mode set to ON to enable auto-close function.

Photo Beam Mode allows the door to close once the beam has been tripped and restored. Smart Openers strongly recommend the installation of a PE safety beam to protect persons and property (Factory Default = Off).

- 1 Connect PE beam cable to controller terminal black as per Fig. 37.
- 2 Press **MENU** for 3 secs then press **SET** to cycle through to display `Photo Beam Off`.
- 3 Press **MENU** to choose `On` (Fig. 38).
- 4 Press **SET** to confirm or **MODE** to save and exit.

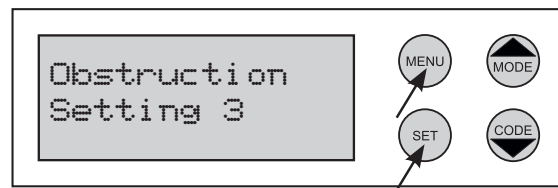

Fig. 34

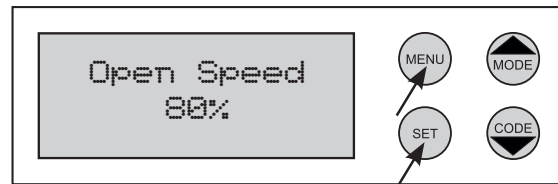

Fig. 35

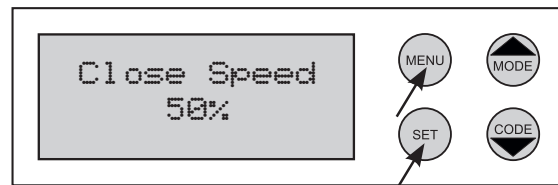

Fig. 36

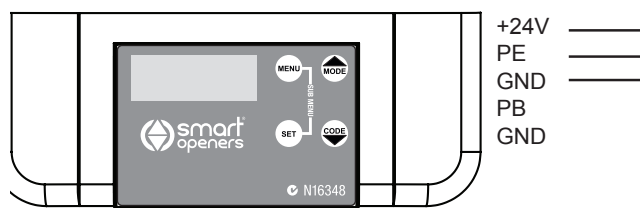

Fig. 37



Fig. 38

Setting Auto-Close Mode

Auto-Close Mode allows the door to close automatically once the PE safety beam has been tripped and the preset time has elapsed. This function is only available with the addition of a functioning photo-electric safety beam (Factory Default = Off).

Auto-Close Mode allows you to set a timer from 001–180 seconds before the door begins to close. In this mode the door will close if the photo beam is not triggered after the time has elapsed.

Important: If the photo beam is tripped within the time limit the door will close 5 secs after the beam is restored.

- 1 Make sure that a functioning PE beam is connected and Photo Beam Mode is set to On as per Page 10.
- 2 Press **MENU** for 3 secs then press SET to display Auto-Close Off.
- 3 Press **MENU** to choose On (Fig. 39).
- 4 Press **SET** to confirm or **MODE** to save and exit.

Setting Auto-Close Time Delay

Auto-Close Time delay is used with Auto-Close Mode to allow the door to close automatically after the timer has elapsed (Factory Default = 30 Secs).

Note: Auto-Close Mode must be enabled to use this function.

1. Press **MENU** for 3 secs then press **SET** to display Auto-Close Delay.
2. Press and hold **MENU** to increase or PB to decrease delay time in 1 sec increments (Max. 180 secs) (Fig. 40).
3. Press **SET** to confirm or **MODE** to save and exit..

Setting PE-Close Mode

PE-Close Mode allows the door to close automatically once the PE safety beam has been tripped and 5 secs has elapsed. This function is only available with the addition of a functioning photo-electric safety beam (Factory Default = Off).

Important: The door will remain open until the beam is tripped.

- 1 Make sure that a functioning PE beam is connected and Photo Beam Mode is set to On as per Page 10.
- 2 Press **MENU** for 3 secs then press **SET** to display PE-Close Off.
- 3 Press **MENU** to choose On (Fig. 41).
- 4 Press **SET** to confirm or **MODE** to save and exit..

NOTE: PE-Close and Auto-Close can both be active at the same time. If Auto-Close is active with a 30 second delay then the door will close in 30 secs regardless whether the PE has been triggered. If the PE beam is triggered during that 30 seconds then the door will close 5 secs after the beam is restored.

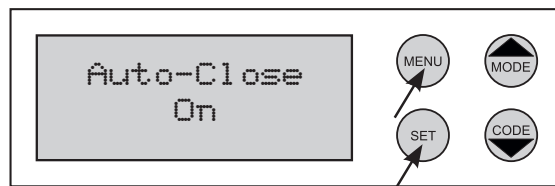

Fig. 39



Fig. 40

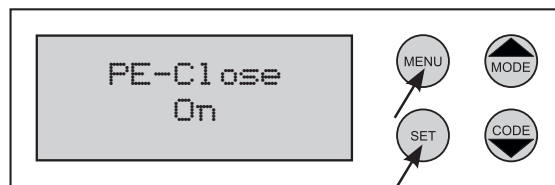

Fig. 41

Hands Free Learning

Hands Free Learning allows the coding of new transmitters via an existing already coded remote instead of pressing the CODE button. This function is useful if multiple remotes are to be coded for one site. (Factory Default = On).

- 1 To disable this function press **MENU** for 3 secs then press **SET** to display HF Learning On.
- 3 Press **MENU** to choose Off (Fig. 42).
- 4 Press **SET** to confirm or **MODE** to save and exit.

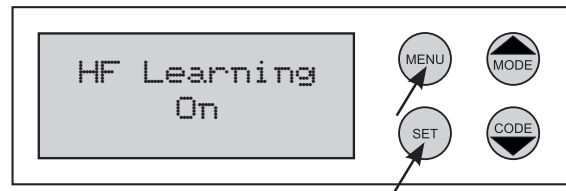

Fig. 42

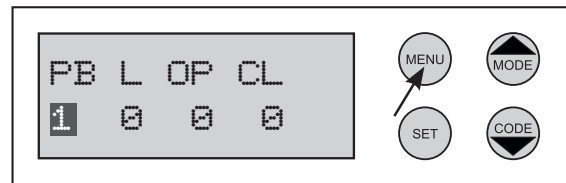
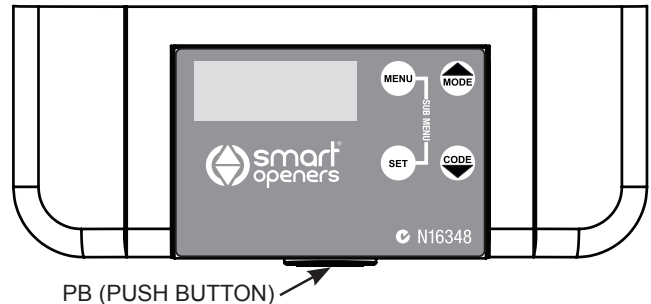
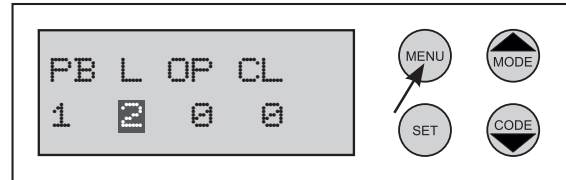

Fig. 43



PB (PUSH BUTTON)

Fig. 44

Transmitter Button Allocation

The button chosen on the first transmitter that was coded into memory (Pg 9) determines which button becomes the default for **all** subsequent transmitters to be coded into this opener. This is useful for sites where there are multiple openers so that Hands Free Learning via a pre-coded remote will automatically allocate all buttons to their function in one action. You can change the button allocation without clearing the receiver memory via the following procedure.

Note: These settings affect all coded transmitters.

- 1 Press **MENU** for 3 secs then press **SET** to cycle to the TX Button Allocation screen as per Fig. 43.
- 2 Press **MENU** to scroll to the desired function:
PB = Push Button (Open/Stop/Close function)
L = Light
OP = Open Button
CL = Close Button.
- 3 Press **PB** to allocate required button number. (Fig. 44).

Note: To allocate **ALL BUTTONS** to the same function press and hold **PB** (Fig. 44) until the display shows **All**.

- 4 Press **SET** to confirm or **MODE** to save and exit.

Testing Obstruction Margin

- 1 Test the obstruction force margin sensitivity by placing a piece of timber approximately 40mm thick on the floor in the doorway (Fig. 45).
- 2 Close the door onto the timber. If the door does not reverse easily and attempts to continue to close adjust the force margin as per procedure on page 12.

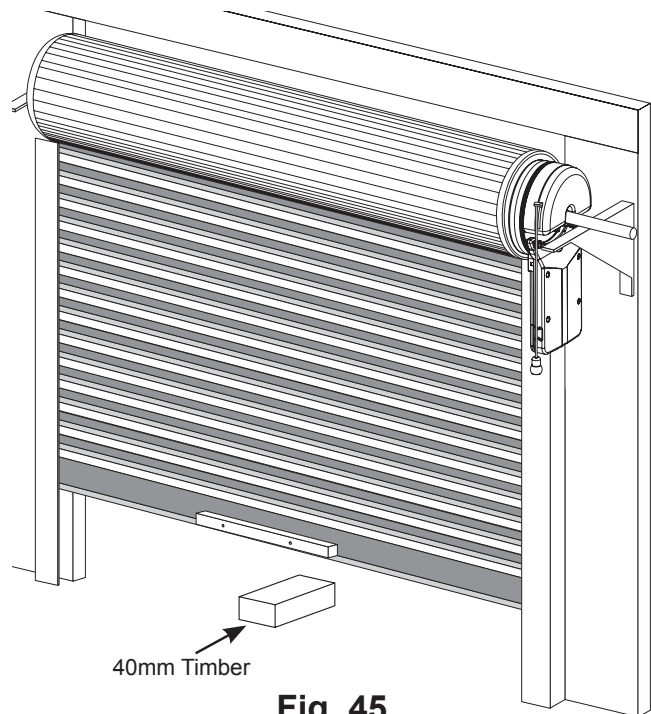

Fig. 45

Important Information for the User

Once the Smart Roller Nano opener has been installed, the user must be informed about how it works and all the risks that can arise if it is used improperly. The user must avoid placing himself/herself in dangerous situations such as standing within the door's operating range when it is moving.

Do not let children play near the door and keep the remote controls out of their reach.

All servicing, repairs or checks must be carried out by professionally qualified personnel and noted on a maintenance register kept by the user.

Information for the user is found in the USERS/OWNERS MANUAL included with this opener.

IMPORTANT: Please make sure the USERS/OWNERS MANUAL is passed on to the owner prior to leaving the installation.

IMPORTANT: In the case of a malfunction the user must call an authorized Smart Opener Pty Ltd installer and should not attempt to repair the opener.

Maintenance

No particular maintenance is required for the logic circuit board.

At least twice a year check that the door is properly balanced and that all working parts are in good working condition.

IMPORTANT: A poorly operating door can effect the life of the automatic opener due to incorrect loads and will void the warranty.

Check the reversing sensitivity at least twice a year and adjust if necessary.

Make sure that the safety devices are working effectively (photo beams, etc.)

Final Notes

- This installation manual is only for use by technical personnel qualified to carry out the installation.
- No information given in this manual can be considered of any interest to the end user.
- No setting or adjustments contained in this manual can be carried out by the end user.
- It is important for the installer to show the user correct operational use of the Smart Roller Nano including the use of the manual disengagement cord.
- Inform the user about the need for regular and accurate maintenance, especially regarding a regular check of the safety and reversing devices.
- **Please ensure that the owners manual is passed on to the user and is retained for their future reference.**

Technical Specifications

Power Input:	240 VAC \pm 10% 50Hz
Motor:	24V DC 120W
Courtesy Light Time:	3 minutes approx.
Working Temperature:	-20° ~ 70°C
Relative Humidity:	<90%
Open & Close Force:	600N
Max. Door Area:	16m ²
Reception Frequency:	433.22MHz
Storage Capacity:	20 Transmitters
Decoding:	Rolling code
Transmitter Battery:	27A 12V Battery
Courtesy Light:	LED Array

NOTE: Smart Openers Pty Ltd reserves the right to modify its product and product specifications at any time without prior notice.

Warranty and Exclusion of Liability

1. This warranty is an addition to any conditions or warranties that are implied by relevant statute, including the Trade Practices Act 1974 (Cth), which cannot be excluded or negated.
2. Subject to all of the matters set out below, **Smart Openers** Pty Ltd ("**Smart Openers**") warrants:
 - (a) swing and sliding gate opener drive units for twelve (12) months
 - (b) roll-up and overhead door opener drive units for twenty four (24) months
 - (c) all components and accessories for twelve (12) months, from the date of purchase (specified in the sales docket receipt) as free of any defects in material and workmanship.
3. This warranty applies only where the purchaser:
 - (a) immediately notifies **Smart Openers** or the retailer of the alleged defect;
 - (b) returns the product to Smart Openers or the retailer; and
 - (c) presents the relevant sales docket and this warranty document to the retailer and, if so requires, to Smart Openers to confirm the date of purchase.
4. Defects or damage partly or wholly due to any of the following causes are not covered by this warranty:
 - (a) accidental damage to any of the Product or to the Product's components;
 - (b) normal wear and tear to the Product or to the Product's components;
 - (c) flood, rain, water, fire, lightning, storms, any acts of God, contamination or pollution;
 - (d) incorrect, improper, inappropriate or unreasonable maintenance and/or use;
 - (e) installation, adjustment or use which is not in accordance with the instructions set out in installation instructions incorporated in the document;
 - (f) attempted or complete modification or repairs to the Product or tampering with the Product carried out by a person who is not authorised by **Smart Openers** to carry out such modification or repairs;
 - (g) faulty or unsuitable wiring of structure to which the Product is fixed or connected;
 - (h) radio (including citizen band transmission) or any electronic interference;
 - (i) blown fuses or damage caused by electrical surges, power surges or power spikes;
 - (j) damage caused by insects or any infestation;
 - (k) negligence or deliberate damage.
5. Except for this warranty, **Smart Openers** gives no warranties of any kind whatsoever (whether express or implied), in relation to the product, and all warranties of whatsoever kind relating to the product are, to the extent permissible by statute, hereby excluded and negated.
6. To the extent permissible by statute, **Smart Openers** disclaims any liability of whatsoever nature in respect of any claim or demand for loss or damage which arises out of:
 - (a) accidental or deliberate damage to, or normal wear and tear to, the product or to the product's components;
 - (b) any cost relating to damage resulting from wear and tear;
 - (c) blown fuses, loss or damage caused by electrical surges, power surges or power spikes;
 - (d) loss or damage due to theft, fire, flood, rain, water, lightning, storms, any acts of God, contamination or pollution;
 - (e) door or gate not in safe and correct working order and condition;
 - (f) evidence of unauthorised repairs;
 - (g) any cost relating to damage caused deliberately or by misuse, negligence or failure to maintain the equipment in a proper working order, including (without limitation) due to anything described in paragraphs (d) and (e);
 - (h) installation, adjustment or use which is not in accordance with the instructions set out in installation instruction manual and owners manual;
 - (i) attempted or complete modification or repairs to the Product or tampering with the Product carried out by a person who is not authorised or has not been trained by **Smart Openers** to carry out such modification or repairs;
 - (j) faulty or unsuitable wiring of structure to which the Product is fixed or connected;
 - (k) radio (including citizen band transmission) or any electrical interference;
 - (l) damage caused by insects or any infestation;
 - (m) loss or damage to any property whatsoever or any loss, damage or expense whatsoever resulting or arising therefrom;
 - (n) any consequential, indirect, special or incidental loss or damage;
 - (o) any cost or expense arising due to manufacturer recall of any product;
 - (p) any cost or expense due to negligence of the approved service provider;
 - (q) installation of a residential garage door or gate opener in a commercial or industrial situation or a non-single residential dwelling.
7. **Smart Openers** liability under this warranty is limited, at **Smart Openers** absolute option, to replacing or repairing the product which **Smart Openers**, in its unfettered and absolute opinion, considers to be defective either in material and/or workmanship or to credit the dealer with the price at which the product was purchased by the dealer.
8. This warranty does not extend to cover labour for installation.
9. This warranty is limited to Return-to-Base (RTB) repair and does not cover labour for on-site attendance.
10. This warranty is void if the Product is not returned to the manufacturer in original or suitably secure packaging.
11. This warranty is only applicable for repairs to the Product carried out within Australia and for Product in Australia.
12. This warranty does not cover consumable items including globes, batteries and fuses.
13. This warranty is not transferable.
14. Where the Product is retailed by any person other than **Smart Openers**, except for the warranty set out above, such person has no authority from **Smart Openers** to give any warranty or guarantee on **Smart Openers** behalf in addition to the warranty set out above.

Notes:

1. This warranty is to be read in conjunction with the installation manual and owner's manual.

Smart Openers Pty Ltd

PO Box 6666 GCMC, Qld 9726

Tel: 1300 366 547 Fax: 1300 366 972

Email: enquiries@smartopeners.com

Web: www.smartopeners.com

© February 2009 Smart Openers Pty Ltd. All rights reserved.

No part of this publication may be reproduced, utilised, transmitted, or distributed in any form by any means including photocopying, recording, mechanical, electronic or otherwise by any party, without the written permission from the publisher Smart Openers Pty Ltd. Copying without authorisation is ILLEGAL. In an ongoing commitment to product quality and innovation Smart Openers reserves the right to change and alter specifications and model numbers and types without notice.

D/N: SRNIMA5REV09