

PowerGlide

Sectional Door Operator

This is a SmartLifter

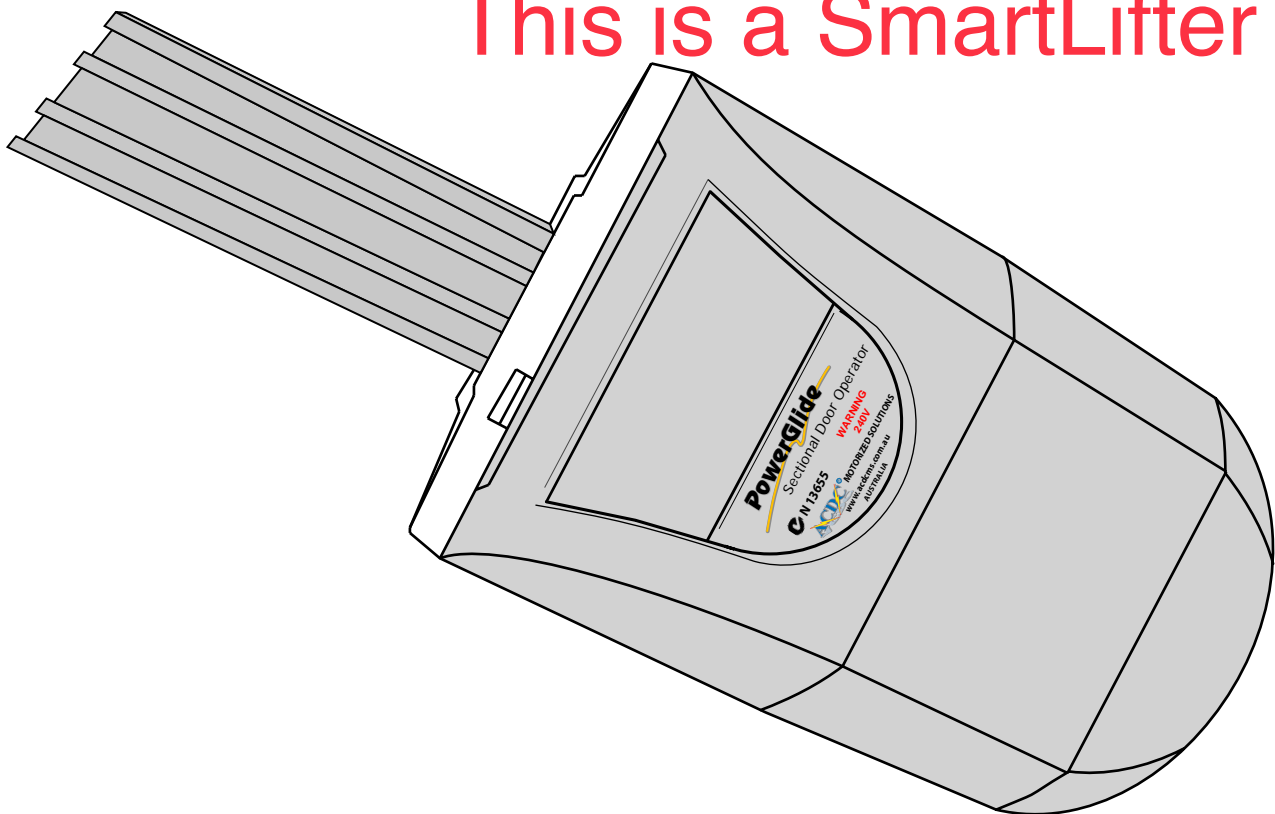

WARNING:

It is crucial that these instructions are carefully read and followed. Failure to do so can result in serious personal injury, property damage and/or damage to the door operator.

Installation should only be undertaken by qualified personnel.



MOTORIZED SOLUTIONS
AUSTRALIA
www.acdcms.com.au

 N13655

TABLE OF CONTENTS

1, Package Contents	Page 3
2, Important Safety Warning	4
3, Product Description & Features	4
4, Pre-Installation Checks	5
5, Installation Procedure	5
6, Programming the Opener	8
6.1 Programming Controls	8
6.2 Setting Open & Close Limits	8
6.3 Coding Hand Transmitters	8
6.4 Setting Obstruction Force Sensitivity	9
6.5 Setting Additional Accessory Modes	9
7, Electronic Connections	10
8, Manual Disconnect	10
9, Maintenance	10
10, Technical Specifications	11
11, Warranty Terms	11

1. PACKAGE CONTENTS

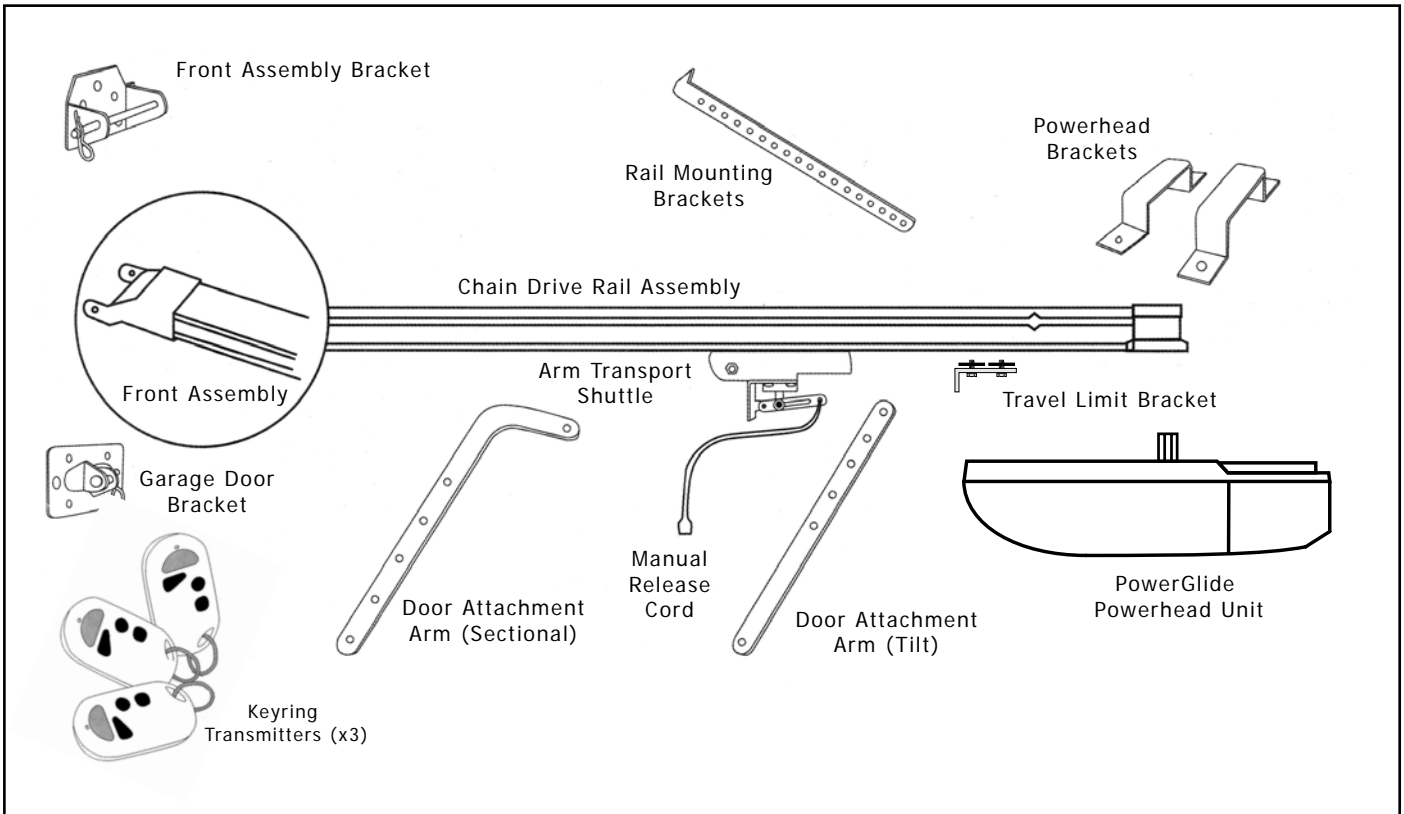

DESCRIPTION

QUANTITY

PowerGlide Powerhead Unit	x 1
Chain Drive Rail Assembly	x 1
Installation & Owners Manual	x 1
Rail Mounting Brackets	x 4
Door Attachment Arm	x 2
ACDC Key-Ring Transmitters	x 3
Manual Release Cord	x 1
Replacement 240V Globe	x 1
Accessory Pack	x 1
Including:	
Arm Transport Shuttle	x 1
Garage Door Fixing Bracket	x 1
Front Rail Fixing Bracket	x 1
Powerhead Attachment Brackets	x 2
Travel Limit Bracket	x 1
Nuts & Bolts Kit	x 1

2. IMPORTANT SAFETY WARNING



IT IS IMPORTANT THAT THESE INSTRUCTIONS ARE FOLLOWED CORRECTLY. FAILURE TO COMPLY MAY CAUSE SERIOUS PERSONAL INJURY AND/OR PROPERTY DAMAGE.

ACDC recommends the use of safety devices, such as Photo Electric Beams for additional safety on every automatic door installation. The ACDC **PowerGlide** garage door opener described in this manual is for domestic overhead sectional and tilt door applications. Any other use is considered improper and will void any warranty.

The installation should be carried out by a qualified technician. It is the responsibility of the installer to adhere to all installation instructions and safety warnings & regulations. Installations that do not comply with this manual will void any warranty.

The garage door should only be used when in full view of the door, and free from children/persons, pets or objects. Do not allow children to play with or operate the door hand transmitters. Keep transmitters away from children. Severe injury or damage can result from failure to follow this warning.



The ACDC PowerGlide garage door opener operates on 240V AC. Basic precautions should be observed to reduce the risk of fire, electric shock or injury. The mains power lead must be connected to a 240V mains power outlet installed by a qualified electrician, and out of reach by children. Disconnect the power cord from the mains power outlet before doing any repairs or removing the cover. Only a qualified service technician should remove the cover of the garage door opener.

The opener should not be exposed to water or rain, and should be installed so that it is protected from the elements.

The garage door must be well balanced before installing the opener. If the door is heavy to lift, or does not open & close smoothly it must be repaired by a qualified garage door installer prior to installing the garage door opener.

Periodic maintenance is required to maintain optimum performance. Check the door is opening & closing smoothly and that the opener is safely and securely mounted.

The garage door opener has an obstruction sensing feature. For the obstruction sensing to detect an object in the door way, some force will be applied to the object which may suffer damage or injury to the object, person and/or door.

3. PRODUCT DESCRIPTION & FEATURES

The ACDC **PowerGlide** garage door opener is designed for domestic Overhead Sectional & Tilt doors. It requires a 240V AC 50Hz power input.

INTELLIGENT OPERATION

The PowerGlide uses a 24V DC 100W Motor Drive unit, together with a smart controller and encoder system. The unit memorises the limit positions and incorporates a unique braking system that slows the unit down at the end of its travel; minimising any noise and vibration.

CONVENIENCE

The PowerGlide comes equipped with Rolling Code Transmitters to open and close the door. Alternatively, an optional wall switch can be connected to the unit. At any stage of operation, the transmitters and wall switch can interrupt and reverse the door.

The controller also offers automatic closing by an adjustable timer, and inputs for Photo Electric Safety Beams (which must be used in Auto Close Mode). The Photo beam will automatically stop and reverse the door should an object be in the door way on closing.

FUNCTIONALITY

The unit is equipped with a manual release lever which allows manual operation of the door in case of power failure. Alternatively an optional battery back-up device is available to electrically operate the door in cases of power failure.

The controller also offers a Security Lock-out function which prevents operation of the door from any transmitter or wall switch. This gives peace of mind when going on vacation or when needing to restrict access to the door.

4. PRE-INSTALLATION CHECKS

Before commencing installation the following checks must be done;

- * The Garage door must be able to open and close easily by hand and without too much effort. A well balanced & sprung door is critical for proper installation.
- * The garage door opener cannot compensate for a badly installed garage door and should not be used as a solution for a 'hard to open' door.
- * If the unit is being installed on an existing door, make sure any existing locking devices are removed.
- * A 240V mains power outlet must be installed near where the opener is being installed.
- * There should be a minimum gap of 30mm between the bottom of the chain drive rail and the top of the garage door at it's closest point. (Refer Fig. 1)
- * **Failing to comply with these pre-checks will void any warranty.**

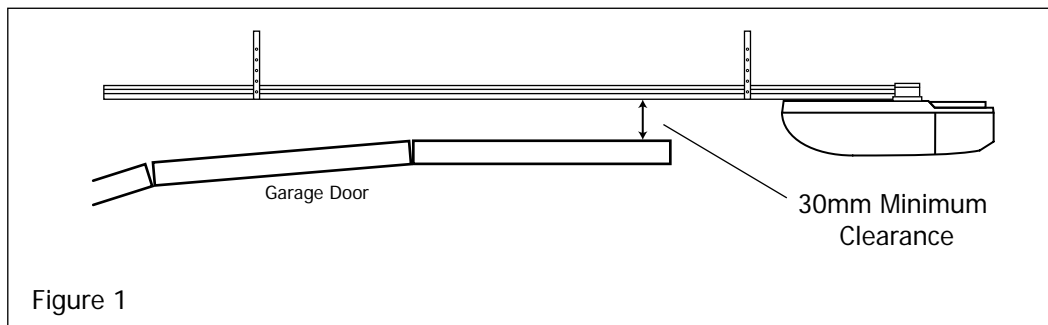

5. INSTALLATION PROCEDURE

STEP 1 (Fig. 2)

Close the garage door and measure the garage door width at the top, and mark the centre. Locate and mount the front assembly bracket approximately 65mm above the door on the inside wall.

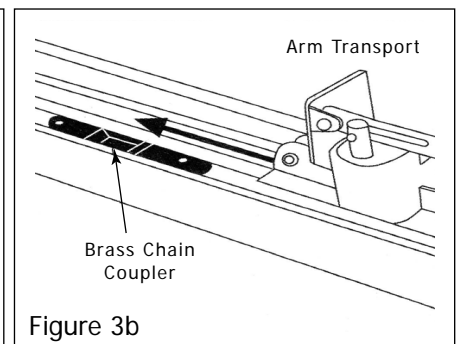
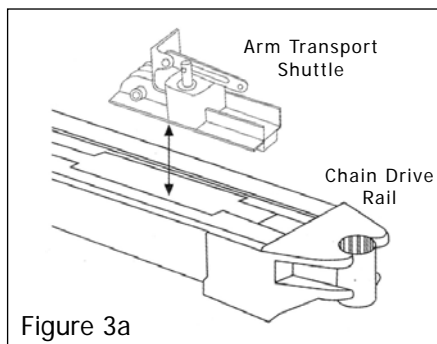
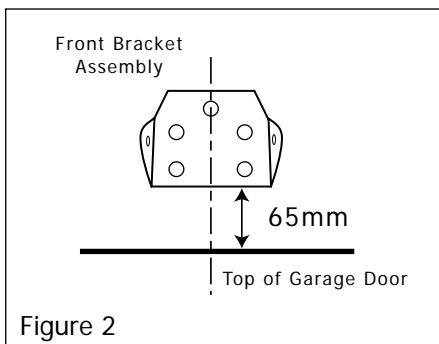

STEP 2 (Fig. 3a & b)

Insert the Arm Transport Unit (Shuttle) into the cut-out at the end of the chain drive rail. Be sure it faces the right direction (the disconnection arm on the shuttle faces towards the Powerhead). Slide the shuttle along the rail until it locks into place with the brass chain coupler.

Move the whole shuttle assembly to the centre of the drive rail.

5. INSTALLATION PROCEDURE

STEP 3 (Fig. 4a)

Using the 6mm Rail Mounting bolts supplied, slide 2 bolts in each side of the rail through the cutouts provided. Use the 6mm Nuts to secure the Rail Mounting Brackets.

Alternative mounting can be done from the bracket on the Powerhead using the 6mm hexagon head bolt, washer & nut provided. (Fig. 4b)

STEP 4 (Fig. 5)

Attach the Powerhead (with the control panel facing the door) to the chain drive rail, ensuring the drive spindle is engaged into the chain drive. Assemble the two mounting brackets with the 6mm nuts supplied. Note: The wider bracket fits nearest the drive spindle.

STEP 5 (fig. 6)

Place the chain drive rail and powerhead assembly centrally on the garage floor, with the powerhead furthest away from the door. Lift the front of the drive rail up to the front bracket assembly that has been mounted above the garage door. Insert the main pivot pin through the assembly and secure it with the split pin supplied.

STEP 6 (Fig. 7)

Lift and support the powerhead (with a ladder) so it is positioned centrally and level. Using the brackets supplied, mount the powerhead by attaching to the ceiling rafters or rafter noggins. There are many mounting options, however the recommended method is to use the mounting rails on the side of the powerhead, as well as the support of the chain drive rail side mounting bolts.

IMPORTANT NOTE: In any installation the chain drive rail must be supported halfway along its length to prevent any flex in the drive rail assembly. Failure to do so will void any warranty.

WARNING: Do not allow children around the door, opener or supporting ladder. Serious injury and/or damage may result from failure to follow this warning.

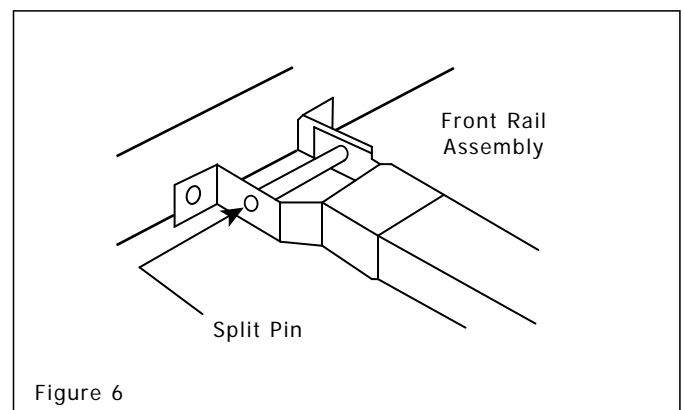
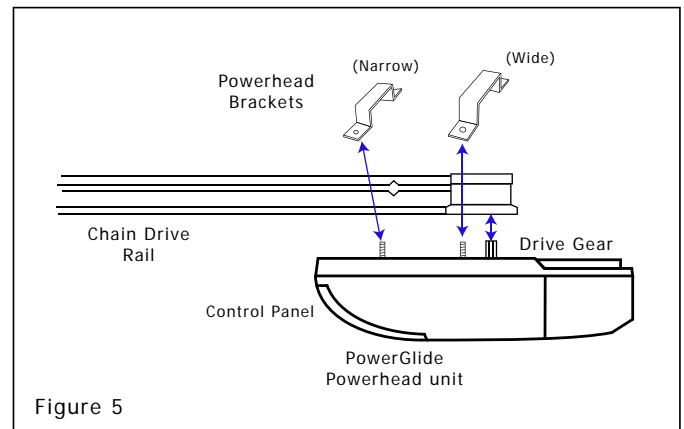
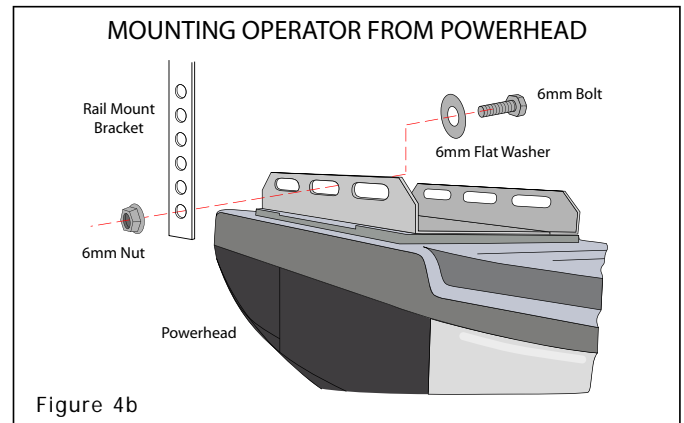
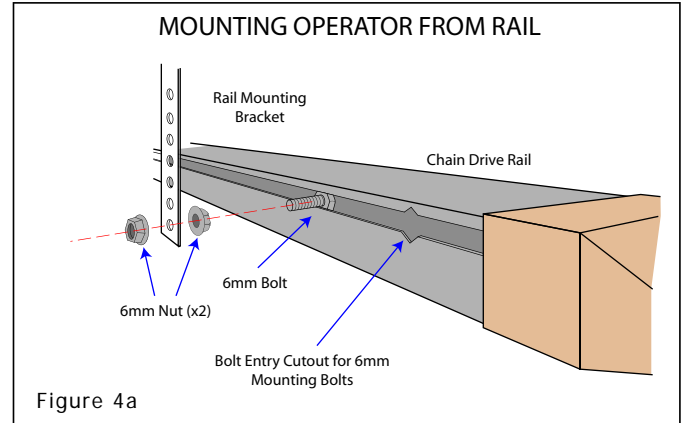

5. INSTALLATION PROCEDURE

STEP 7 (Fig. 8)

Attach the manual disengagement cord to the shuttle assembly. This should be set at a reachable height of approx. 1.8metres. Pull the cord down to free up the shuttle, and then slide the shuttle towards the closed garage door.

Select and attach the appropriate door connecting arm to the shuttle, then attach the garage door bracket to the other end. Position and bolt the bracket to the top edge of the door using the bolts supplied.

STEP 8 (Fig. 9)

Lift the garage door until the shuttle locks back into the drive chain. Attach the travel limit bracket to the chain drive rail towards the powerhead, and tighten the bolts on the assembly.

IMPORTANT NOTE: The travel limit bracket prevents over travelling of the door when in manual operation. Failure to fit this bracket will void any warranty should the door come in contact with the powerhead.

Installation is now complete, and you are now ready to program the unit.

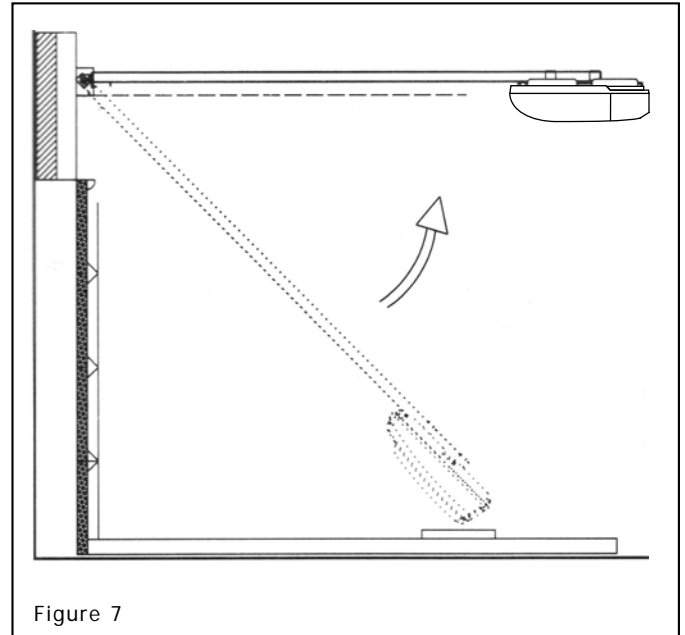

Figure 7

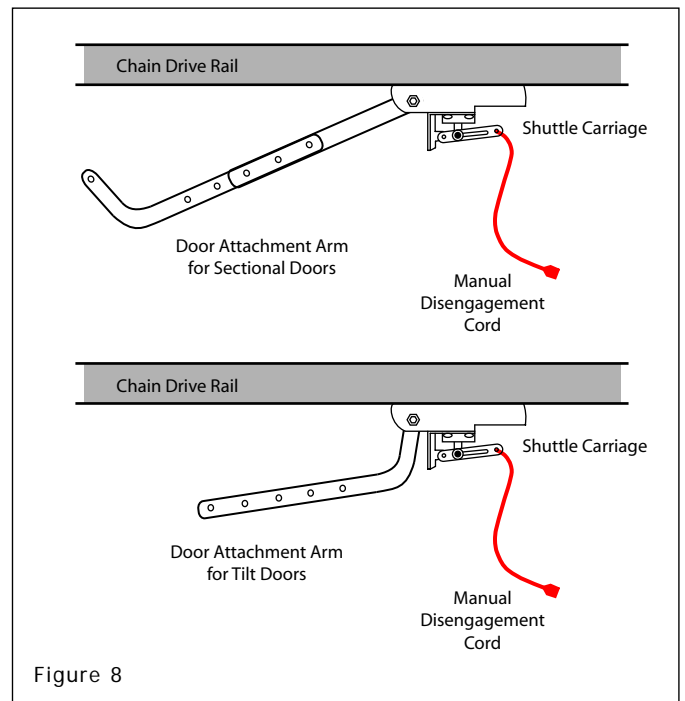

Figure 8

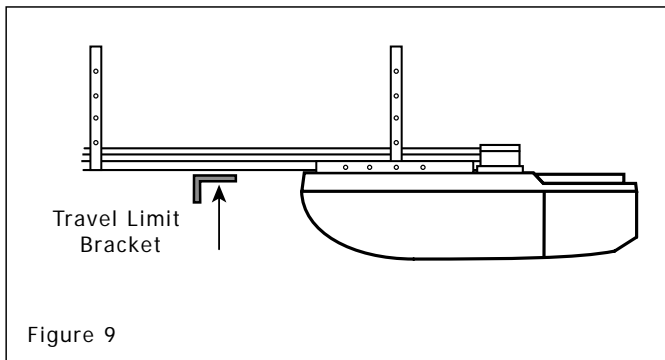
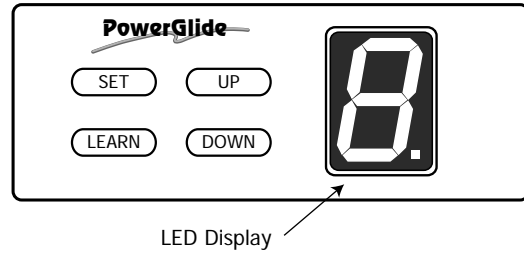

Figure 9

6. PROGRAMMING

6.1 PROGRAMMING CONTROLS

- SET** = Mode Set & Confirm Functions
- LEARN** = Transmitter Code Set & Clear Function
- UP** = Up Limit Function
- DOWN** = Down Limit Function



6.2 PROGRAMMING OPEN & CLOSE LIMITS

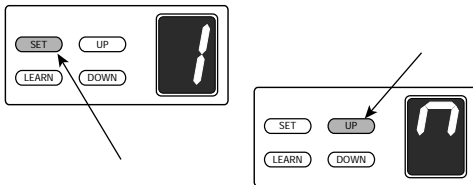

- 2a Press and hold **SET** until **1** is indicated on the LED display (the opener is now in programming mode)
- 2b Press and hold **UP** to set the OPEN limit, release the button when the door has reached the desired position.

Note: If the door has overrun the open position, press **DOWN** to move the door downwards. **UP** & **DOWN** can be used to make fine position adjustments.

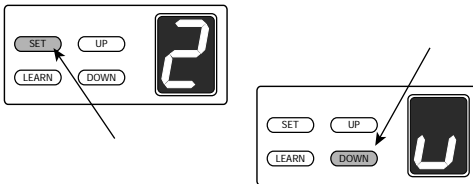

- 2c Press **SET** to confirm the OPEN limit position. The LED display will now indicate the number **2**.
- 2d Press and hold **DOWN** to set the CLOSE limit, release the button when the door has reached the desired position.

Note: If the door has overrun the close position, press **UP** to move the door upwards. **UP** & **DOWN** can be used to make fine position adjustments.

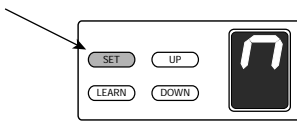

- 2e Press **SET** to confirm the CLOSE limit position.
CAUTION:
The door will now do a complete open & closed cycle to map its end of travel limits, and set its sensitivity requirements. The door is now set for normal operation.

6.3 PROGRAMMING HAND TRANSMITTERS

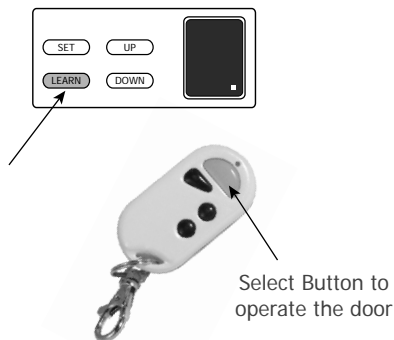

- 3a **Storing the Hand Transmitters**
Press and release **LEARN**. A dot will be indicated in the corner of the LED display.
- 3b Press the button (one of four) on the transmitter you would like to use to control the door for 2 seconds, pause for 2 seconds, then press the same button again on the transmitter for 2 seconds.
The Dot in the corner of the display will flash to confirm the code, then turn off. Repeat this process for additional remotes that need to be stored.

Note: The POWERGLIDE operator is fitted with 'Last Code Delete' which means that only one button per Transmitter can be stored to operate the unit. This function prevents over coding stored transmitters when there are multiple users accessing the same garage door. The other three buttons on the transmitter can be programmed to access automatic gates, security or courtesy lights, etc.

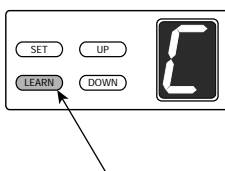

- 3c **Deleting Stored Transmitters**
Press and hold **LEARN** for 10 seconds, until C flashes on the LED display. This indicates that all stored transmitters have been deleted.

6. PROGRAMMING

6.4 ADJUSTING OBSTRUCTION FORCE SENSITIVITY

Note: The force sensitivity is only operational in the **CLOSING** direction. If the door meets an obstruction while closing, it will stop and reverse open 10~15cm.

The Obstruction Force setting is automatically determined and set in the memory of the **PowerGilde** opener. Usually it is not necessary to adjust the sensitivity of the Obstruction Force. In extreme cases, the force sensitivity can be pre-selected to increase or decrease the adjustment.

Please note that the door should be checked to ensure spring tension is adequate before adjusting the Obstruction Force sensitivity.

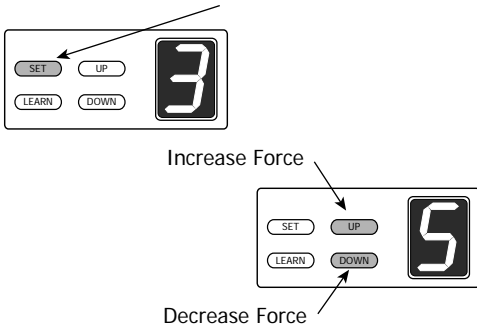

- 4a Press and hold **SET**.
The LED display will cycle through mode settings 1 to 4. When Mode **3** appears on the LED display, release **SET**. The unit is now in Force adjustment mode.
- 4b Press **UP** to increase force setting. Press **DOWN** to decrease force setting. Maximum force setting is Level 9. Minimum force setting is Level 1. Once required force setting is selected, press **SET** to confirm.

6.5 ACCESSORY MODES

The **PowerGilde** opener has 3 selectable accessory modes; Photo Electric Safety Beams, Automatic Closing and Door Lock.

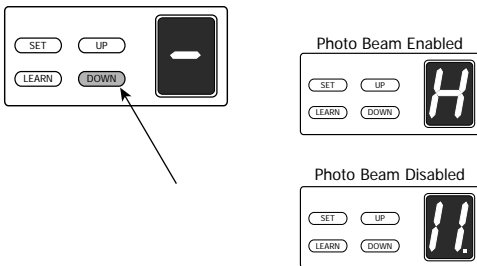

- 5a **Photo Electric Safety Beam**
Press and hold **DOWN** until a horizontal bar is indicated on the LED display. Press **UP** to enable the Photo Beam (**H** will be displayed). Press **DOWN** to disable the Photo Beam (**I** will be displayed).

Press **SET** to confirm the setting.

Make sure the Photo Beam has been installed correctly and using Normally Closed contacts to the accessory terminal on the **PowerGilde** Operator. Refer to Page 7 - Electronic Connections (Fig.),

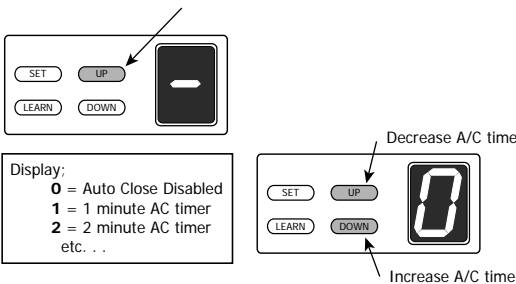

- 5b **Automatic Closing**
Press and hold **UP** until a horizontal bar is indicated on the LED display. Press **UP** again to set the Auto Close time (in minutes). Press **UP** to increase timer, or **DOWN** to decrease timer. To disable Auto Close, set timer to zero (**0**)

Press **SET** to confirm the setting.

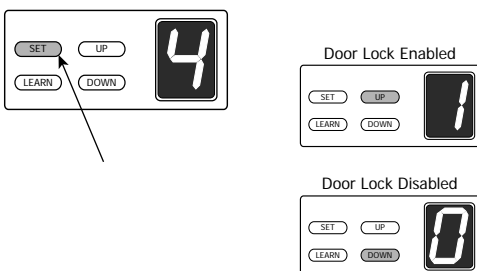

- 5c **Door Lock Mode**
Press and hold **SET**.
The LED display will cycle through mode settings 1 to 4. When Mode **4** appears on the LED display, release **SET**. Press **UP** to enable the Door Lock (**1** will be displayed). Press **DOWN** to disable the Door Lock (**0** will be displayed).

Press **SET** to confirm the setting.

7. ELECTRONIC CONNECTIONS

EXTERNAL TERMINAL CONNECTIONS

The PowerGlide opener has a plug-on terminal block to connect any accessories to the opener.

Figure 10 shows the wiring of a Wall Switch and Photo Electric Safety Beam (Model No. IR5001)

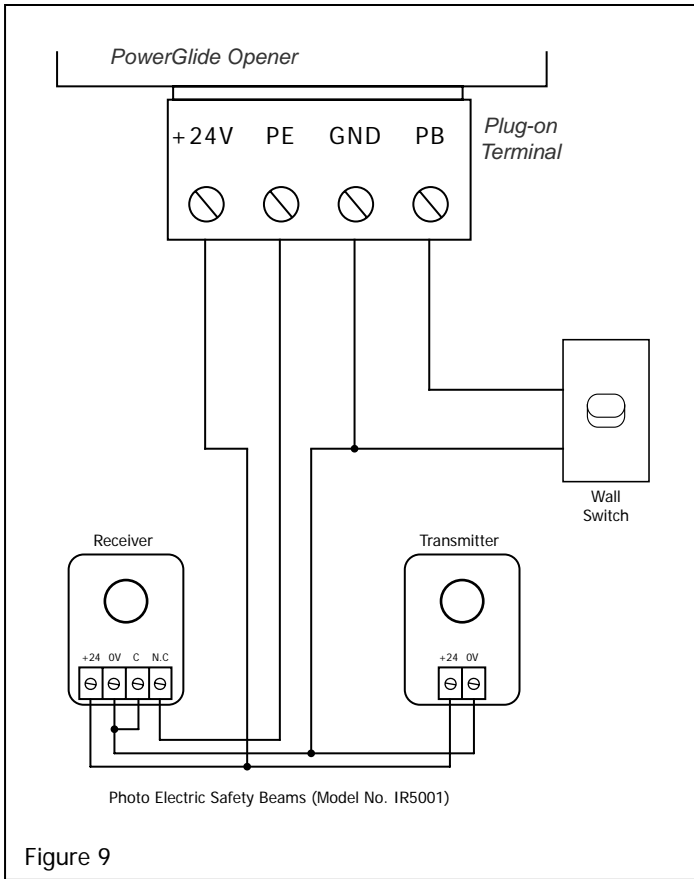

Figure 9

Terminals:

- +24V** 24V DC Power Output (Positive)
- PE** Photo Beam Input (N/C contact)
- GND** Ground (Common)
- PB** Push Button Input (Voltage free)

WALL SWITCH

A wall switch can be connected to terminals PB & GND. On activation of the wall switch, the door will open and close. The switch must be a voltage free, normally open contact.

PHOTO ELECTRIC SAFETY BEAM

A safety beam can be connected to terminals PE & GND. When an obstacle is between the beam, the door will not close. The recommended mounting height of the beam should be approx. 250mm from ground level, and as close to the door as possible. The location of the beam should be positioned to give the maximum protection possible.

WARNING: Ensure mains power cord is disconnected when terminating any accessory to the PowerGlide opener.

8. MANUAL DISCONNECT

The PowerGlide opener is equipped with a manual release lever to open the door in case of power fail situations. To release, pull down on the cord to disengage the shuttle and move the door manually. To reconnect the door, move the door by hand until it re-engages into the shuttle. (Fig. 10)

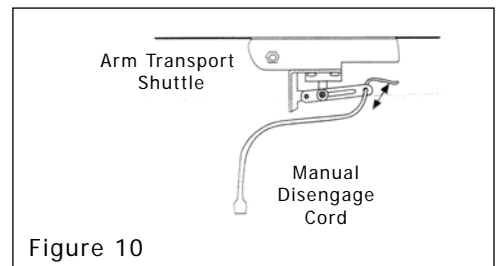

Figure 10

9. MAINTENANCE

The PowerGlide opener requires no particular maintenance. The mounting fixtures should be checked regularly to ensure they remain tight, and are not loosening.

More importantly, the door should be checked every 3-6 months to ensure it is still properly balanced and that all working parts are in good working order.

IMPORTANT NOTE: The life span of the PowerGlide opener can be effected by a poorly operating door due to incorrect loadings, and will void any warranty.

The reversing sensitivity force of the door should be checked every 6 months, and adjusted if necessary.

Regular inspections of the safety devices should be done to ensure they are working effectively and clear of any dust and/or insects (such as photo electric safety beams, etc.).

10. TECHNICAL SPECIFICATIONS

Power Input:	240V AC 50Hz
Protection Fuse:	3 Amps
Controller Voltage:	24V DC
Motor Power:	100 Watts
Opening/Closing Force:	600N
Working Temperature:	-20° ~ 70°C
Courtesy Light Time:	3 minutes
Courtesy light Glode:	15W / 240V Screw-in
Radio Frequency:	433.22 MHz
Transmitter Type:	Rolling Code
Transmitter Battery:	23A 12V Battery
Max. Door Size:	2800(h) x 5000(w)mm
Max. Lifting Capacity:	250N

***Note: ACDC Motorized Solutions Pty. Ltd. have an ongoing commitment to product quality and reserve the right to change specifications without notice.**

11. WARRANTY CONDITIONS

1. This warranty is in addition to any non-excludable conditions or warranties that are implied into this contract by relevant statute, including the Trade Practices Act 1974 (Cth).
2. Subject to all of the terms set out below, ACDC Motorized Solutions Pty Ltd ("ACDC") warrants
 - (a) the PowerGlide overhead door opener drive units for twenty four (24) months; and
 - (b) all components and accessories for twelve (12) months, from the date of purchase (specified in the tax invoice receipt) as free of any defects in material and workmanship.
3. This warranty applies only where the purchaser:
 - (a) immediately notifies ACDC or the retailer of the alleged defect;
 - (b) returns the product to the retailer; and
 - (c) presents the relevant sales invoice and this warranty document to the retailer to confirm the date of purchase.
4. To the extent permissible by statute, ACDC disclaims any liability of whatsoever nature in respect of any claim or demand for loss or damage which arises out of:
 - (a) accidental damage to or normal wear and tear to the product or to the product's components;
 - (b) any cost relating to damage resulting from wear and tear;
 - (c) blown fuses, loss or damage caused by electrical surges, power surges or power spikes;
 - (d) loss or damage due to theft, fire, flood, rain, water, lightning, storms or any other acts of Nature;
 - (e) door not in safe and correct working order and condition;
 - (f) evidence of unauthorised repairs;
 - (g) any cost relating to damage caused by misuse, negligence or failure to maintain the equipment in a proper working order as per clauses (d) through (f);
 - (h) installation, adjustment or use which is not in accordance with the instructions set out in installation instruction manual;
 - (i) damage caused by insects;
 - (j) loss or damage to any property whatsoever or any loss or expense whatsoever resulting or arising there from or any consequential loss;
 - (k) any cost or expense arising due to manufacturer recall of any product;
 - (l) any cost or expense due to negligence of the approved service provider;
 - (m) installation of a residential garage door in a commercial or industrial situation or a non-single residential dwelling.
5. ACDC's liability under this warranty is limited, at ACDC's absolute discretion, to replacing or repairing the product which ACDC, in its unfettered opinion, considers to be defective either in material and/or workmanship or to credit the dealer with the price at which the product was purchased by the dealer.
6. This warranty does not extend to cover labour for installation.
7. This warranty is limited to Back-to-Base repair and does not cover labour for on-site attendance.
8. This warranty is void if the Product is not returned to the manufacturer in its original or suitably secure packaging.
9. This warranty does not cover consumable items including globes, batteries and fuses.
10. Except for this warranty, ACDC gives no warranties of any kind whatsoever (whether express or implied), in relation to the product, and all warranties of whatsoever kind relating to the product are, to the extent permissible by statute, hereby excluded.
11. Where the Product is retailed by any person other than ACDC, except for the warranty set out above, such person has no authority from ACDC to give any warranty or guarantee on ACDC's behalf in addition to the warranty set out above.



MOTORIZED SOLUTIONS PTY. LTD.

ABN. 19 107 530 521

Website: www.acdcms.com.au

Email: sales@acdcms.com.au

POSTAL ADDRESS

PO Box 2674, Taren Point NSW 2229, Australia

HEAD OFFICE & SHOWROOM

Unit 6&7, 7-11 Parraweena Rd, Caringbah NSW 2229

Ph: 02 9525 6822 Fax: 02 9525 6922

QLD OFFICE & SHOWROOM

Unit 6, 22 Eastern Service Rd, Stapylton QLD 4207

Ph: 07 3287 5422 Fax: 07 3287 5722