



## Program Remotes Go To Page 13

Factory Reset Page 16

Force & Power Settings Page 16

Operator systems for garage doors

Comfort 260, 270, 280

Wire Number Code Page

11



## Table of Contents

<b>1.</b>	<b>General safety instructions</b> .....	<b>3</b>
1.1	Intended use .....	3
1.2	Target group .....	3
1.3	Warranty .....	3
<b>2.</b>	<b>Scope of supply</b> .....	<b>4</b>
<b>3.</b>	<b>Door system</b> .....	<b>5</b>
<b>4.</b>	<b>Installation</b> .....	<b>6</b>
4.1	Preparing for installation .....	6
4.2	Installing the drive .....	6
4.3	Connection of control elements .....	10
4.4	Completing the installation .....	11
<b>5.</b>	<b>Setting in operation</b> .....	<b>12</b>
5.1	Overview of the controls .....	12
5.2	Status display .....	13
5.3	Factory settings .....	13
5.4	Express programming .....	13
5.5	Function test .....	14
5.6	Special programming .....	15
<b>6.</b>	<b>Operation</b> .....	<b>22</b>
6.1	Hand transmitter .....	22
6.2	Release mechanism .....	24
<b>7.</b>	<b>Maintenance</b> .....	<b>24</b>
<b>8.</b>	<b>Disassembly</b> .....	<b>24</b>
<b>9.</b>	<b>Disposal</b> .....	<b>25</b>
<b>10.</b>	<b>Rectifying faults</b> .....	<b>25</b>
<b>11.</b>	<b>Appendix</b> .....	<b>27</b>
11.1	Technical Data .....	27
11.2	Declaration of Incorporation .....	28

### **DANGER!**

#### **IMPORTANT SAFETY INSTRUCTIONS:**

ATTENTION! IT IS VITALLY IMPORTANT FOR THE SAFETY OF PERSONS THAT YOU FOLLOW ALL THE INSTRUCTIONS. KEEP THESE INSTRUCTIONS IN A SAFE PLACE.

#### **IMPORTANT INSTRUCTIONS FOR SAFE INSTALLATION:**

ATTENTION! SERIOUS INJURIES CAN BE CAUSED IF THE EQUIPMENT IS NOT INSTALLED CORRECTLY – BE SURE TO FOLLOW ALL THE INSTALLATION INSTRUCTIONS.

## Regarding this document

- Original instruction manual.
- Part of the product.
- Read these instructions carefully before use and keep them in a safe place for future reference.
- Protected by copyright.
- No part of this manual may be reproduced without our prior approval.
- Subject to alterations in the interest of technical progress.
- All dimensions are given in millimetres.
- The drawings are not true to scale.

### Meaning of symbols

#### **DANGER!**

Safety notice indicating a danger that will directly result in death or severe injury.

#### **WARNING!**

Safety notice indicating a danger that could result in death or severe injury.

#### **CAUTION!**

Safety notice indicating a danger that could result in slight or moderate injuries.

#### **NOTICE**

Safety notice indicating a danger that could result in damage to property or in irreparable damage to the product.

#### **CHECK**

Reference to a check that needs to be carried out.

#### **REFERENCE**

Reference to separate documents that must be observed.

- Instruction requiring action
- List, itemisation
- Reference to other sections of this document
-  Factory settings

# 1. General safety instructions

## DANGER!

### **Failure to comply with the documentation could result in life-threatening danger!**

- Be sure to follow all the safety instructions in this document.

## 1.1 Intended use

- The operator system is to be used only for opening and closing doors.
- Never use the door system to help lift persons or objects.

The following applies for the products Comfort 260, 270, 280:

- Only approved for use in dry rooms.
- The following values must be observed:
  - maximum tensile force
  - maximum compressive force
  - maximum door size
  - maximum door weight
- „11.1 Technical Data“
- The product is intended for private use.
- The product is suitable only for counterbalanced sectional and up-and-over doors with a fall arrest system.

## 1.2 Target group

- Installation, connection and setting in operation: qualified, trained specialist personnel.
- Operation, inspection and servicing: the operator of the door system.

Requirements to be met by qualified and trained specialist staff:

- Knowledge of the general and specific safety and accident-prevention regulations.
- they have knowledge of the relevant electrical regulation,
- Training in the use and care of appropriate safety equipment.
- Adequate instruction and supervision by qualified electricians.
- The ability to recognise hazards that can be caused by electricity.
- Knowledge of the application of the following standards
  - EN 12635 (“Doors and gates - Installation and use”),
  - EN 12453 (“Safety in use of power operated doors - Requirements”),
  - EN 12445 (“Safety in use of power operated doors - Test methods”),

Requirements to be met by the operator of the door system:

- Knowledge and safekeeping of the instruction manual.
- Knowledge of general safety and accident-prevention regulations.

## 1.3 Warranty

The product is manufactured in accordance with the directives and standards listed in the declaration of incorporation. The product left the factory in perfect order with regard to safety.

In the following cases, the manufacturer will accept no liability for damage. The warranty on the product and accessory components becomes void in the event of:

- Failure to observe these operating instructions.
- Incorrect handling and use of the product for anything other than its intended purpose.
- Work being carried out by unqualified personnel.
- Changes or modifications to the product.
- The use of replacement parts that have not been approved or were not manufactured by the manufacturer.

The warranty does not cover batteries, rechargeable batteries, fuses or bulbs.

### **Further safety instructions are given in the relevant sections of the document.**



- „5. Setting in operation“
- „6. Operation“
- „7. Maintenance“
- „8. Disassembly“
- „9. Disposal“

## 2. Scope of supply

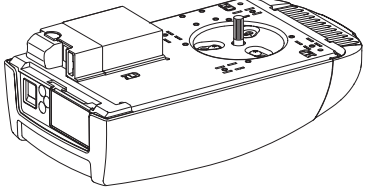
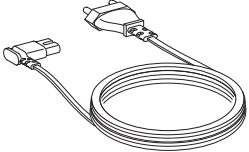
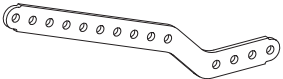
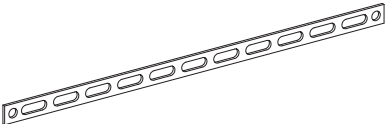
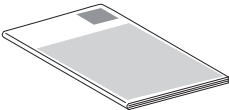

Various versions of the product are available. Please refer to the table and check the items included in the delivery to determine which version you have received.

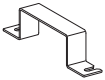
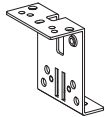
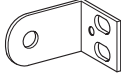
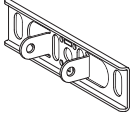
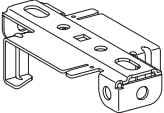
There may be some country-specific differences.

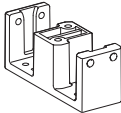



Item	Door operator	
1		1x
2		1x
3		1x
4		2x
5		1x

Item	Fittings	A	B
6		2x	2x
7		1x	1x
8		2x	2x
9		1x	1x
10		2x	2x
11		1x	–
12		1x	–
13		–	1x

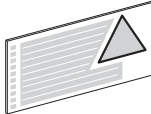
Item	Fastening elements - 01	A	B
14		4x	4x
15		2x	2x
16		1x	1x
17		1x	1x
18		1x	1x
19		1x	1x
20		2x	2x
21		1x	1x
22		1x	–
23		1x	–
24		–	4x

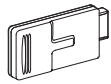
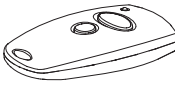
Item	Fastening elements - 02	
25		6x
26		6x
27		6x

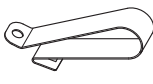
Item	Warning signs	
28		1x
29		1x

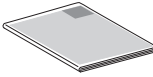
Item	Hand transmitter	Multi-Bit	bi-linked
30		1x	1x
31		1x	–
32		–	1x
33		1x	–
34		1x	–
35		1x	–
36		–	1x

### 3. Door system

#### Overview

3 / 1

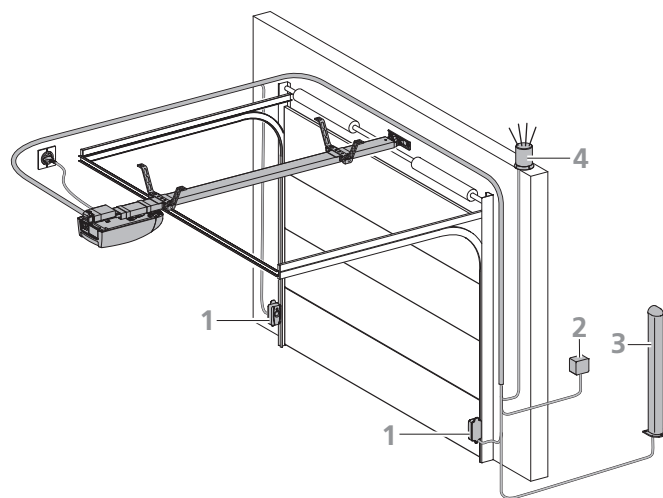

This is just an example of a door system. The details can vary according to the type of door and the associated equipment. The system shown comprises the following components:

- 1 Photocell
- 2 Key switch
- 3 Free-standing post (for code keypad, transponder etc.)
- 4 Signal light

#### REFERENCE

For further information regarding accessory items, please see the manufacturer's website.

For the installation and cabling of the door sensors, control elements and safety equipment, the relevant installation instructions must be observed.

## 4. Installation

### DANGER!

#### Life-threatening danger due to electric shock!

- It is vital that you disconnect the operator system from the power supply before commencing cabling work. Take measures to ensure that the power supply remains disconnected for the duration of the work.
- Observe the local safety regulations.
- It is imperative that you lay power cables separately from control cables.  
The control voltage is 24 V DC.

### NOTICE

#### Material damage resulting from incorrect installation of the operator!

To avoid installation errors and damage to the door or operator system, the following installation instructions must be observed at all costs.

- Ensure that the door is in good mechanical condition:
  - The door remains stationary in every position.
  - The door can be moved easily.
  - The door opens and closes properly.
- Install all impulse transmitters and control equipment (such as radio code buttons e. g.) within sight of the door and at a safe distance from the door's moving parts. The installation height must be at least 1.5 metres from the ground.
- Only use fixing materials that are suitable for the foundation material in question.

### 4.1 Preparing for installation

Before commencing installation, the following works must be carried out without fail.

#### Supply package

- Check which version you have received and that all the parts are present.
- Ensure that a suitable operator boom is available.
- Check that all the necessary accessory parts for your installation situation are present.

#### Garage

- Check to make sure that your garage has a suitable power connection and a mains disconnection switch.

#### Door system

- Remove any components (such as ropes, chains, brackets, etc.) from the door that are no longer needed.
- All equipment that will no longer be required after the door operator system has been installed must be taken out of service.

For garages without a second entrance:

- Fit the garage door with an emergency release mechanism so that you can gain entry to the garage if there is a malfunction.

If a release set is used:

- Check that the door catches function properly. On no account should the door catches be taken out of service.

If no release set is used:

- Remove the door catches or take them out of service.

### REFERENCE

When using and installing accessory equipment, observe the corresponding documentation.

### 4.2 Installing the drive

4.2 / 1

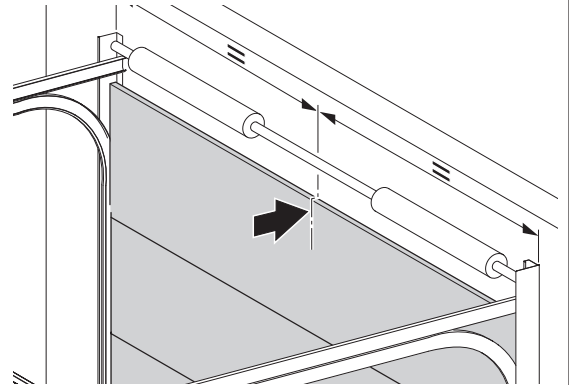

4.2 / 2

A

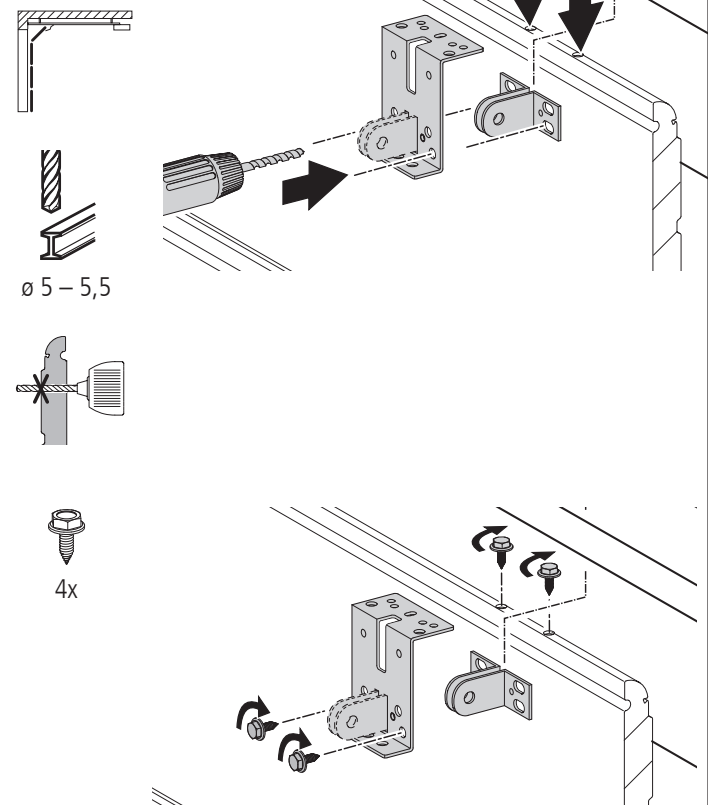

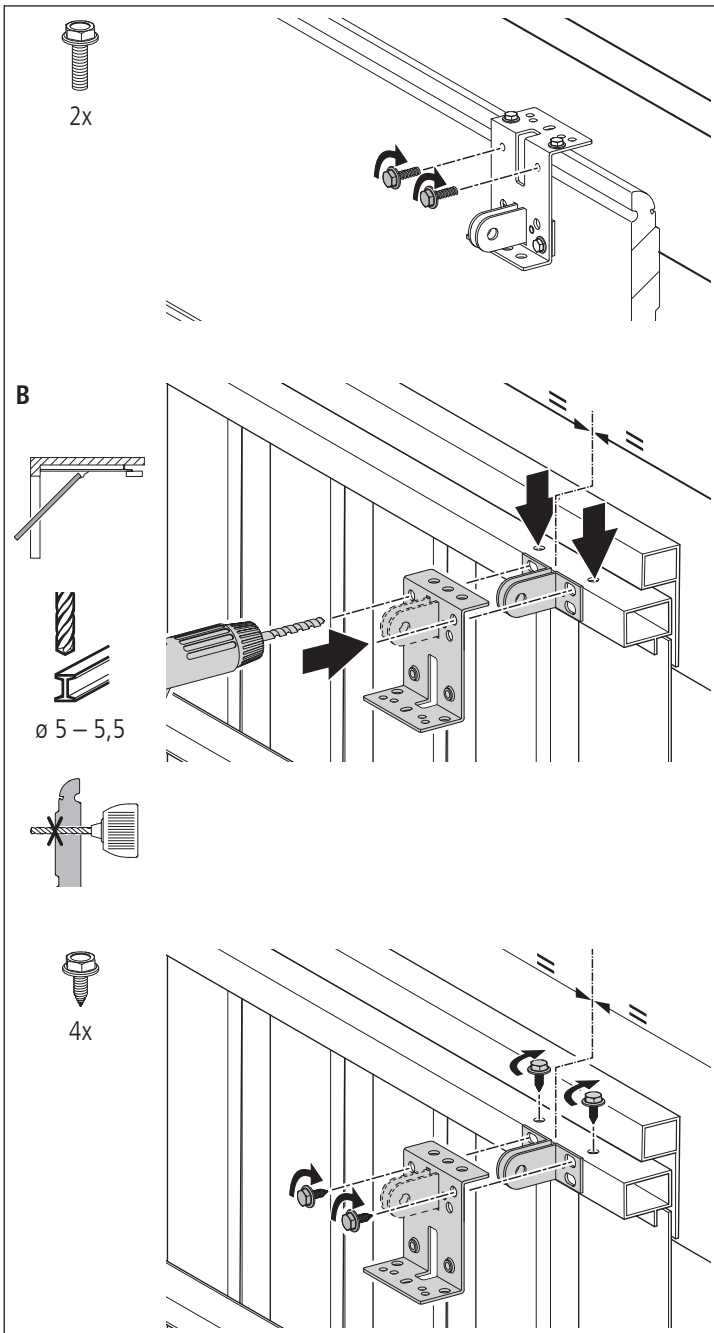

## NOTICE

### Possibility of damaging the motor unit!

Do not use force, as this could damage the teeth of the gears!

- Carefully fix the operator boom to the motor unit.

### 4.2 / 3

A



1x



4x

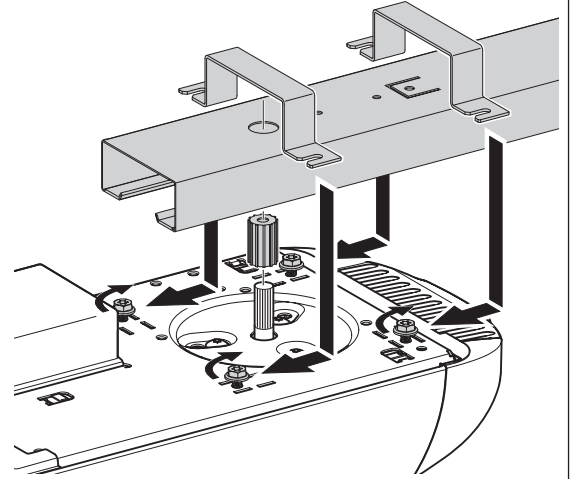

B



1x



4x

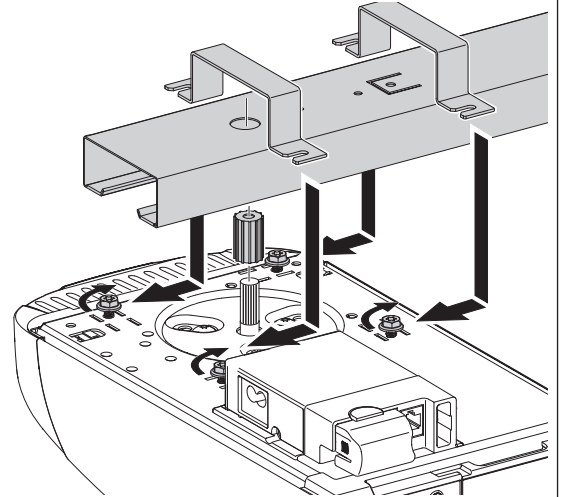

### 4.2 / 4



1x

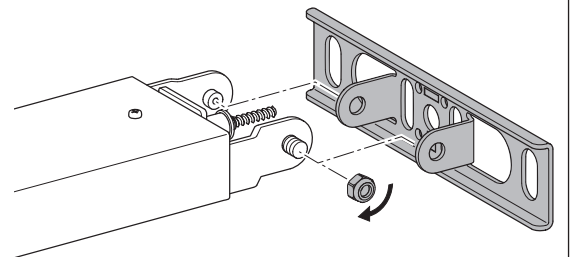

**⚠ WARNING!**

**Possibility of serious injury due to falling components!**

- Secure the operator system to prevent it from falling before it is properly fixed in place.

4.2 / 5

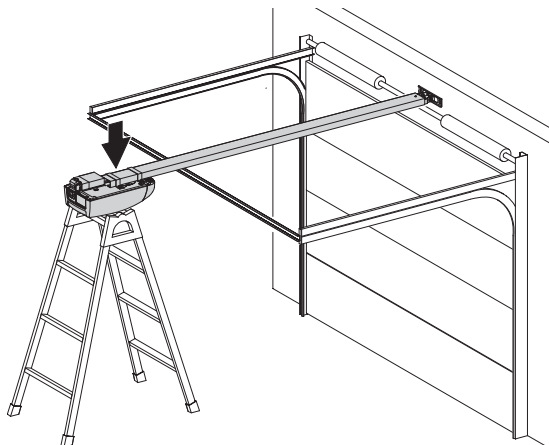

**👉 NOTICE**

**Possibility of damaging the door leaf!**

At its highest point during opening, the top edge of the door leaf must be 10 - 50 mm below the bottom edge of the horizontal operator boom.

- Fix the lintel joining plate for the operator boom. It must be positioned centrally above the door leaf.

4.2 / 6

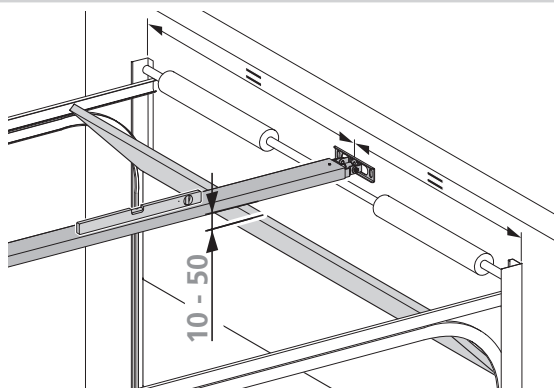

4.2 / 7

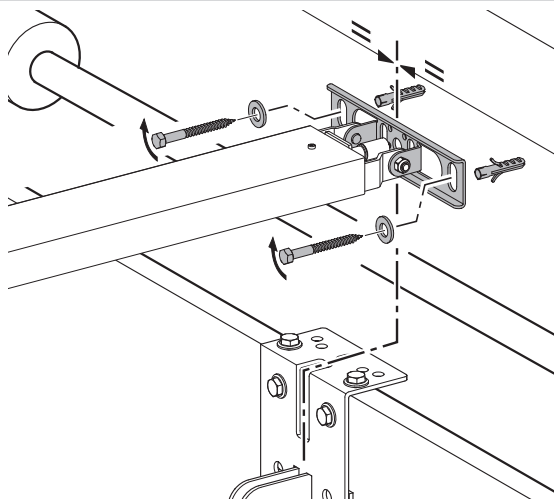
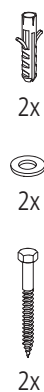

4.2 / 8

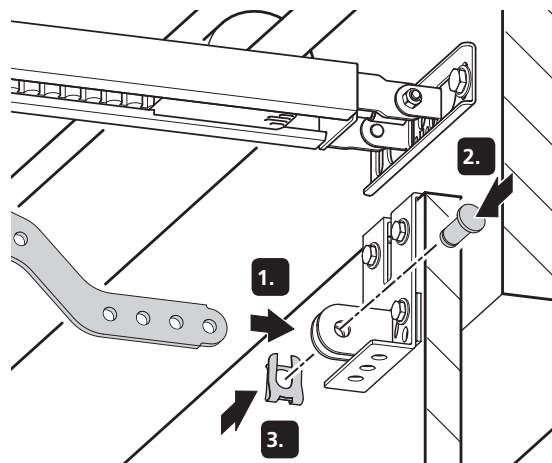
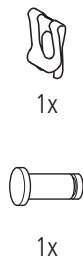

4.2 / 9

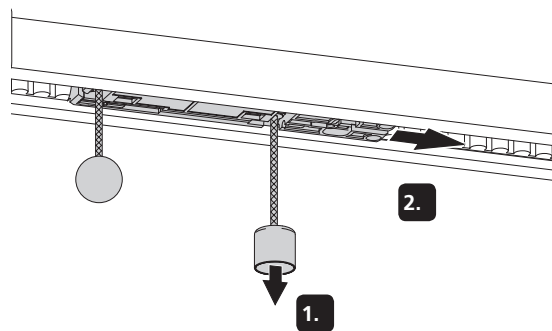

4.2 / 10

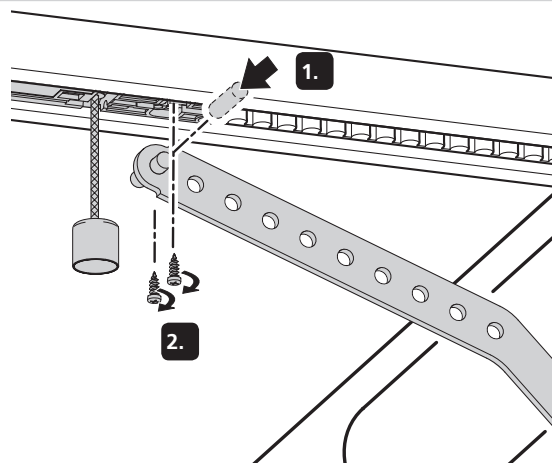

4.2 / 11

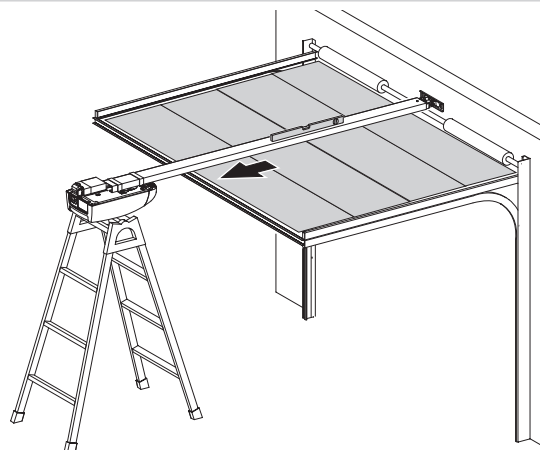

4.2 / 12

A



1x



1x

a = 90°  
b = 9 Nm

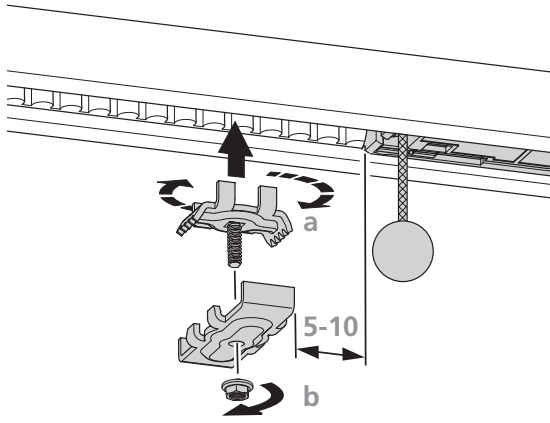

B



4x

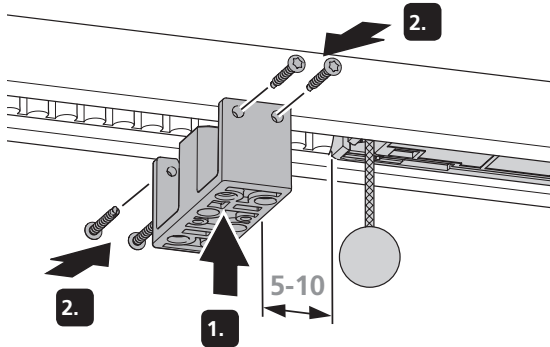

4.2 / 13

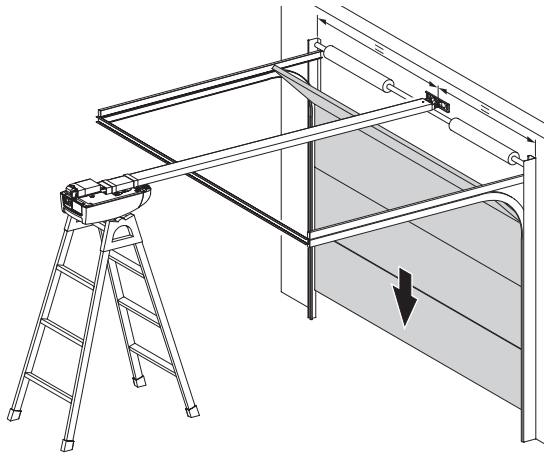
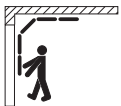

4.2 / 14

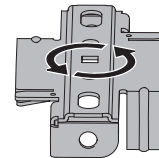
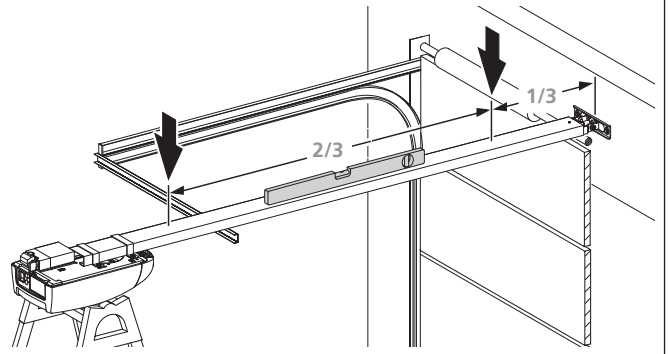

2.

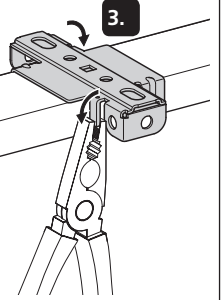

3.

4.2 / 15



ø 10

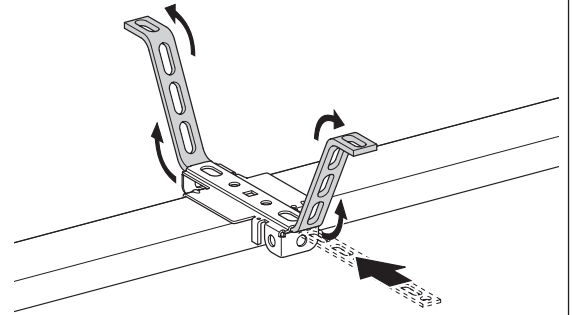

4.2 / 16



2x



2x



2x

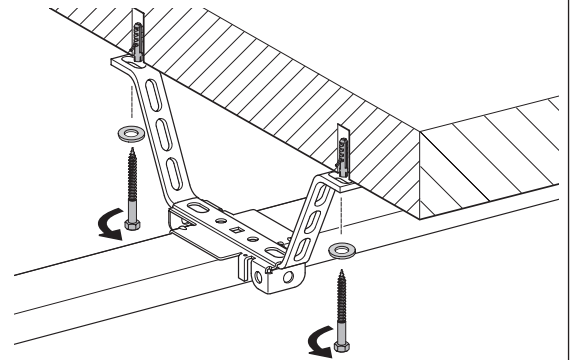

## 4.3 Connection of control elements

### **⚠ DANGER!**

#### **Life-threatening danger due to electric shock!**

- It is vital that you disconnect the operator system from the power supply before commencing cabling work. Take measures to ensure that the power supply remains disconnected for the duration of the work.

### **👉 NOTICE**

#### **Danger of material damage resulting from incorrect installation of the operator!**

If an external voltage is connected to terminal block XB03, the entire electronic system will be irreparably damaged.

- Connect only potential-free contacts to terminals 1, 2 and 4 (XB03).

## 4.3.1 Overview of the control element connections

4.3.1 / 1

**Go to Page 11**

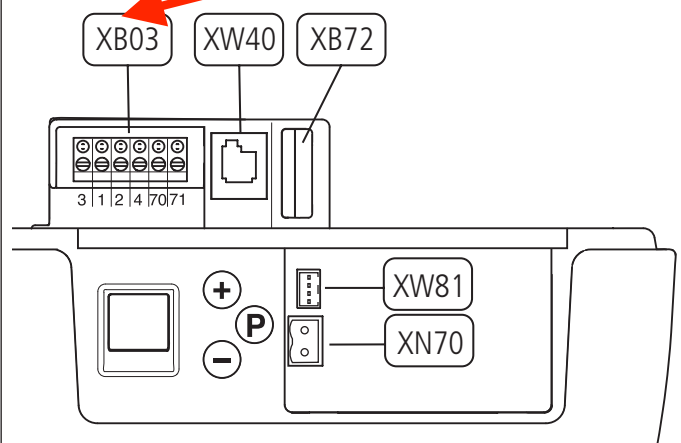

XB03	Connection for <ul style="list-style-type: none"> <li>external control elements</li> <li>Photocell</li> </ul> → „Level 5, Menu 1 - Programmable impulse input (terminal 1/2)“ → „4.3.3 Terminal block XB03“
XB72	Connection for modular antenna → „4.3.2 Terminal block XB72“
XN70	Connection for battery backup → „4.3.4 Connections XN70 and XW81“
XW40	Connection for MS bus expansion module
XW81	Connection for expansion inputs / outputs → „4.3.4 Connections XN70 and XW81“

## 4.3.2 Terminal block XB72

4.3.2 / 1

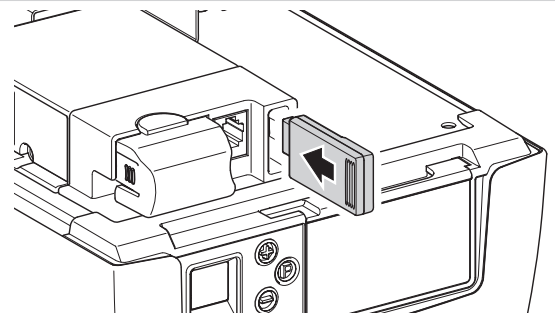

### 4.3.3 Terminal block XB03

4.3.3 / 1

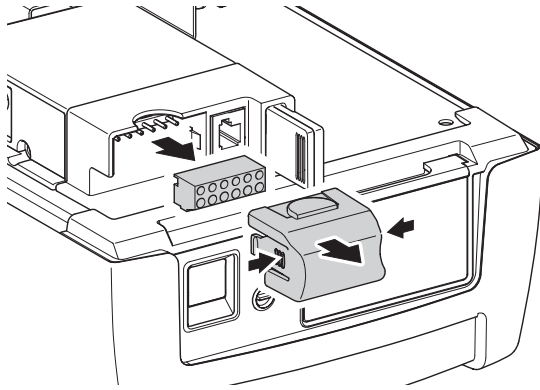

4.3.3 / 2

M11E021

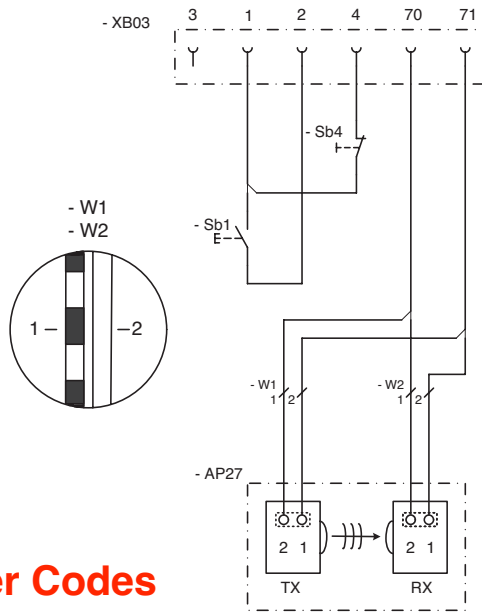

### Number Codes

1	GROUND -
2	Impulse
3	24 V DC + / 50 mA max.
4	Hold circuit, active after a reset
70	GROUND
71	Photocell
AP27	Photocell
RX	Photocell receiver
TX	Photocell transmitter
Sb1	Impulse button
Sb4	Normally closed contact for hold circuit

4.3.3 / 3

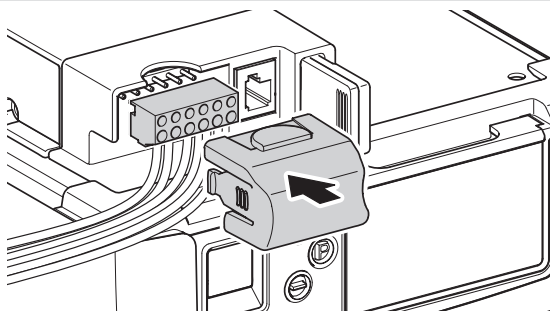

### 4.3.4 Connections XN70 and XW81

4.3.4 / 1

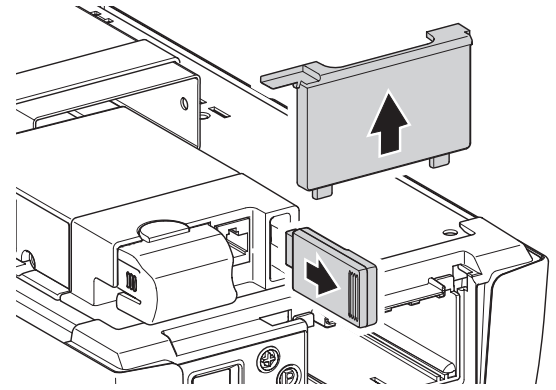

### REFERENCE

See the separate documentation for instructions on installing the connected elements.

4.3.4 / 2

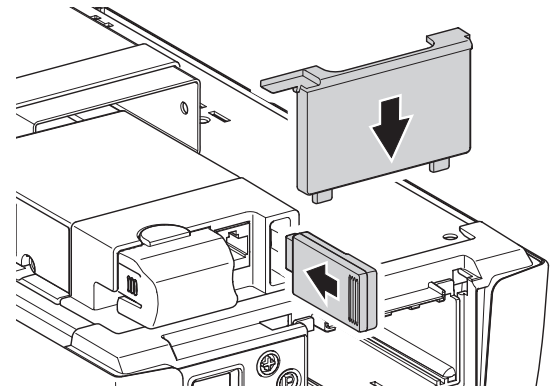

## 4.4 Completing the installation

4.4 / 1

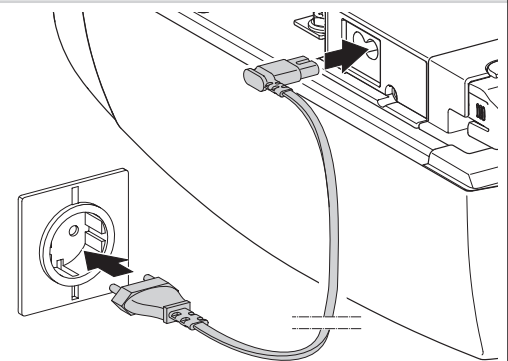

- Take the warning signs regarding trapping hazards and affix them permanently at noticeable locations.
- After installation is complete, ensure that no door parts extend onto the public footpath or the street.

## 5. Setting in operation

Before initial operation and at regular intervals of no more than one year, power-operated windows, doors and gates must be inspected by a qualified person (whereby written inspection records must be kept). After setting the system in operation, the operator of the door system, or the operator's representatives, must be instructed in the operation of the system.

### WARNING!

#### Danger of injury due to uncontrolled movement of the door!

- Ensure that children can not play with the door controls or the hand transmitter.
- Before setting the door in motion, make sure that no persons or objects are within the danger zone of the door.
- Before going through the door opening, make sure that the door is in the OPEN position.
- Check all the existing emergency command devices.
- Pay attention to potential crushing and shearing zones in the door system.
- Never touch a running door, the guide rail or any moving parts.
- The regulations of DIN EN 13241-1 ("Doors and gates - Product Standard") must be observed.

### 5.1 Overview of the controls

#### Control elements



LED display



Drive the door in the OPEN direction, increase the value



Drive the door in the CLOSE direction, decrease the value



Start programming, confirm and save values











#### Legend





The display flashes

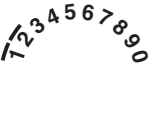
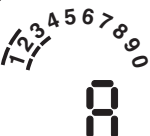

Display lights up

Display	Function / Element
	Ready for operation
	Door position: CLOSED
	Door position: OPEN
	Fault message / Maintenance indicator in CLOSED door position
	Photocell or closing edge safety device
	Remote control
	External button
	Status display (example: 3 = Battery backup connected) → „5.2 Status display“
	Level indicator (example: Level 2)
	Menu and parameter indicator (example: Menu 3, Parameter 8)
<b>Minute indicator</b>	
	Times exceeding one minute are shown in minutes and seconds. Example: 1.2 = 1 minute + 20 seconds = 80 seconds

## 5.2 Status display

Display	Function / Element
	Battery backup connected (optional)
	Warning time indicator (only for programmed automatic closing)

## 5.3 Factory settings

Using the reset procedure, the operator parameters can be restored to their original factory settings.

→ „Level 1, Menu 8 – RESET“

## 5.4 Express programming

To set the operator system properly in service and after every reset, the express programming procedure must be carried out.

Requirements:

- The door must be in the CLOSED position.
  - The carriage must be coupled up.
- „6.2 Release mechanism“

When in programming mode, the controls will revert automatically to operating mode if a period of 120 seconds passes without any buttons being pressed.

A corresponding fault number will be displayed.

→ „10. Rectifying faults“

- Carry out the express programming procedure.

### CHECK

A function test must be carried out after express programming.

→ „5.5 Function test“







**If changing remotes codes to ensure the old remote codes are deleted The only way to be 100% sure everything is deleted and the new remotes code is the only one working is to do the doors limits again in the express set up on this page to the right as shown and then you will have the only remote working.**

**Installing new remotes are done by cloning them as to page 23 for genuine remotes or cloning using cloning remotes**





**NOTES: I have found doing a Factory RESET does not always delete the remotes**

## Express programming







### 1. Programming the "OPEN" door position

	The control system is in operating mode.	
	P > 3 sec. < 10 sec.: Start express programming.	
	Drive the door to the OPEN position.	
	Save the OPEN position.	

### 2. Programming the "CLOSED" door position











	Drive the door to the CLOSED position.	
	Save the CLOSED position.	

### 3. Programming the remote control Multi-Bit

	Press the hand transmitter button.	
	Release the hand transmitter button.	
	Save the remote control setting. End express programming.	
	The control system is in operating mode.	

## Express programming

### 3. Programming the remote control bi-linked

	Open the rear panel of the hand transmitter.	
	Press the programming button on the hand transmitter.	
	Press the hand transmitter button.	
	Release the hand transmitter button.	
	Save the remote control setting. End express programming.	
	The control system is in operating mode.	
	Close the rear panel of the hand transmitter.	









## 5.5 Function test

### 5.5.1 Programming run for setting the driving power

During the first two runs after the door positions have been programmed, the operator system determines the maximum required driving power.

- Drive the operator system (with the door coupled up) from the CLOSED door position to the OPEN position and back again, without interruption.
- Check the driving power.

#### Check the driving power

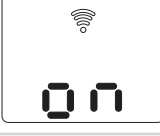
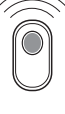
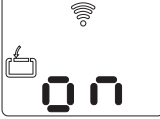
1.		The control system is in operating mode.	
2.		The door should open and move to the saved "OPEN" door position.	
3.		The door should close and move to the saved "CLOSED" door position.	
4.		The door operator should move the door in the OPEN or CLOSE direction. Richtung ZU bewegen.	
5.		The operator system should stop.	
6.		The operator system should run in the opposite direction.	

## 5.5.2 Checking the automatic cut-out

### WARNING!

#### **Danger of injury due to incorrectly programmed values for the door driving power!**

- Check the automatic cut-out function in the OPEN and CLOSE directions.

#### **Automatic cut-out in the OPEN direction**

This checking procedure only applies to operator systems that are installed to operate doors that have openings in the door leaf (with openings > 50 mm in diameter):

- During travel, apply a load of 20 kg to the door at the mid point of the bottom edge of the door:  
The door should stop immediately.

#### **Automatic cut-out in the CLOSE direction**

This checking procedure applies to all door systems.

- Place an object, 50 mm in height, on the floor.
- Drive the door towards the obstacle:  
The operator system should stop and reverse when it touches the obstacle.

The settings for the driving power in the OPEN and CLOSE directions remain saved even if the mains power supply is interrupted.

The parameters are returned to the factory settings only after a reset.

→ „Level 1, Menu 8 – RESET“

## 5.5.3 Checking the photocell

### **Photocell**

- Check all the photocells individually by triggering them.
- Check all the photocells just before the door reaches the CLOSED position.

### **Special points regarding door-frame photocells**

- A door-frame photocell must function above the position at which it is installed. Below the installation position, the function of the photocell is suppressed by the control unit.
- If several photocells are connected, all the photocells function in the same way as a door-frame photocell, if present.

## 5.6 Special programming

### WARNING!

#### **Danger of injury due to incorrect settings for the door driving power!**

Important factory settings can be changed when programming the special functions.

- Check the programmed parameter values.
- Check the programmed door driving power values after changes have been made to the automatic cut-out setting.  
→ „5.5.2 Checking the automatic cut-out“
- Carry out the necessary measurements to validate the correct force limitation.

### NOTICE

#### **Material damage resulting from incorrect programming of the door operator.**

After a reset, all the parameters are returned to the factory settings. Safety elements that are operational and are connected to the system will be recognised anew after a reset.

To ensure that the controls functions properly:

- Reprogram all the required functions.
- Reprogram the remote control.
- Drive the operator system once to the OPEN position and then the CLOSED position.

If a photocell is connected, it will be automatically detected by the control system as soon as the power supply is connected.

The photocell can be reprogrammed later.

Photocells that are not required must be disconnected before the power supply is connected; otherwise they will be recognised by the controls.

→ „4.3.3 Terminal block XB03“

### CHECK

A function test must be carried out after changes have been made in programming mode.

→ „5.5 Function test“

**Factory reset is Level 1, then Menu 3, then select Programmed Value 8 or higher in this menu and press P / Then all cleared——In Menu 8 on the next page it has other options as well**

### 5.6.1 Programming the special functions

#### Programming procedure

## Start to Programming here

1.	The control system is in operating mode.	
2.	P > 10 sec.: Start programming the extended operator functions. Display the levels.	
3.	 Select the level required (example: Level 2).	
<b>READ THIS EXAMPLE BEFORE YOU START</b>		
4.	Confirm the level required. Display the first menu and the programmed parameter.	
5.	 <b>Top Line = Level</b> Select the menu required (example Menu 3). <b>Bottom Line = Menu</b>	
6.	Confirm the menu required. Display the programmed parameter value.	
7.	 Change the parameter value.	
8.	Save the parameter value. The control system switches to display the levels	
	 Select the next level required. Continue programming.	
<b>or</b>		
9.	P > 5 sec.: Finish programming. All the altered parameters are saved.	
	The control system is in operating mode.	

### 5.6.2 Overview of the special functions

Level	Menu	
1 Basic functions	3 Intermediate OPEN position	
	4 Intermediate CLOSE position	
	7 Relay output	
	8 RESET	
2 Operator settings	1 Driving power required to OPEN	
	2 Driving power required to CLOSE	
	3 Automatic cut-out in the OPEN direction	
	4 Automatic cut-out in the CLOSE direction	
3 Automatic closing timer	1 Automatic closing timer	
	3 Door open duration	
	4 Warning time	
	5 Start-up warning	
	7 Signal light	
4 Remote programming	2 Intermediate OPEN position	
	3 Intermediate CLOSE position	
	4 OPEN	
	5 CLOSE	
5 Special functions	8 Operator lighting ON / OFF	
	1 Programmable impulse input	
	3 Programmable input	
	4 Lighting duration	
	5 Hand-held programming device	
	7 Battery back-up	
	6 Variable speed	1 OPEN speed
		2 Soft run OPEN speed
		3 Soft run OPEN position
		4 CLOSE speed
5 Smart run CLOSE speed		
6 Soft run CLOSE speed		
7 Smart run CLOSE position		
8 Soft run CLOSE position		
9 Soft start time OPEN		
10 Soft start time CLOSE		
7 Maintenance and servicing	1 Door cycle counter	
	2 Servicing counter	
	3 Servicing interval	
	8 Reset maintenance and servicing	
	9 Fault indicator	

**Programmed Value Display Can then Be Changed Using + or \_**

Level	Menu
8 System settings	1 Photocell
	2 Closing edge safety device
	3 Automatic cut-out function
	4 Operating modes
	5 Function of the direction command transmitters
	6 Function of the impulse command transmitters
	7 Stress relief in the CLOSED door position (back jump)
	8 Direction of rotation
	9 Changing the display language
	10 Position of the door-frame photocell

### 5.6.3 Contents of the special functions

#### Level 1 – Basic functions

##### Menu 3 – Intermediate OPEN position

Adjust the setting using the + (OPEN) and – (CLOSE) buttons.  
The closing function with automatic closing is possible.  
Only the intermediate position that was programmed last can be used.

##### Menu 4 – Intermediate CLOSE position

Adjust the setting using the + (OPEN) and – (CLOSE) buttons.  
The closing function with automatic closing is not possible.  
Only the intermediate position that was programmed last can be used.

#### Level 1 – Basic functions

##### Menu 7 – Relay output

(only programmable with optional signal light relay)

1	 Signal light (present / not present) → „Level 3, Menu 7 - Signal light“
2	Door position: OPEN
3	Door position: CLOSED
4	Intermediate OPEN position
5	Intermediate CLOSE position
6	Operator system starts (wiping impulse, 1 second)
7	Fault
8	Lighting duration → „Level 5, Menu 4 - Lighting duration“
9	Locking mechanism release (operator system running)
10	Locking mechanism release (operator system immobile)
11	Release lock (operator system starts / wiping impulse, 3 seconds)
12	Push-open security device
13	Radio remote control (relay is activated for the duration of the impulse)
14	Test impulse for the closing edge safety device (relay transmits a test impulse and is activated for 300 ms)

##### Menu 8 – RESET **This is Level 1 then Menu 8**

The operator system can be reset to the factory settings.

1	 No reset
2	Reset the controls
3	Reset the remote control (telegrams are deleted)
4	Reset the special function: automatic closing timer → „Level 3 - Automatic closing timer“
5	Reset only the special operator functions (except the OPEN/CLOSED door positions and the remote control impulse)
6	Reset the safety elements (photocell / Hold circuit)
7	Reset bus modules (connected bus modules will be programmed in)

**There is also a hard Reset Function that works on other models that is HOLD all 3 buttons down and then the display will start a count down function and once it has counted down you release the buttons and everything will be completely cleared.**

## Level 2 – Door operator settings

### Menu 1 – Driving power required to OPEN

Sensitivity in on a scale of 1 to 16  
(the higher the number, the greater the driving power).  
 8

### Menu 2 – Driving power required to CLOSE

Sensitivity in on a scale of 1 to 16  
(the higher the number, the greater the driving power).  
 8

### Menu 3 – Automatic cut-out in the OPEN direction

Sensitivity on a scale of 1 (OFF) to 16  
(the lower the number, the more sensitive the automatic cut-out).  
 12

### Menu 4 – Automatic cut-out in the CLOSE direction

Sensitivity on a scale of 1 (OFF) to 16  
(the lower the number, the more sensitive the automatic cut-out).  
 8

## Level 3 - Automatic closing timer

### Menu 1 – Automatic closing timer

If the automatic closing function is activated, the relay output (Level 1 / Menu 7) can be reprogrammed if required.

1	 Deactivated	
2	Door open duration 15 / Warning time 5	The open duration can only be increased via an impulse signal (button or hand transmitter).
3	Door open duration 30 / Warning time 5	
4	Door open duration 60 / Warning time 8	
5	Door open duration 15 / Warning time 5	The door open duration ends after the photocell has been triggered.
6	Door open duration 30 / Warning time 5	
7	Door open duration 60 / Warning time 8	
8	Door open duration infinite / Warning time 3	Door closes after the photocell has been triggered / Closing prevention.

## Level 3 - Automatic closing timer

### Menu 3 – Door open duration

2 – 250 seconds.  
 Dependent on Level 3, Menu 1

### Menu 4 – Warning time

1 – 70 seconds.  
 Dependent on Level 3, Menu 1

### Menu 5 – Start-up warning

0 – 7 seconds.  
 0

### Menu 7 – Signal light

1	 Door movement / Warning: Flashing Door stationary: Off (energy saving)
2	Door movement / Warning: Light on Door stationary: Off (energy saving)
3	Door movement / Warning: Flashing Door stationary: Flashing
4	Door movement / Warning: Light on Door stationary: light on
5	Door movement / Warning: Flashing Door stationary: Light on
6	Door movement / Warning: Light on Door stationary: Flashing

## Level 4 – Remote programming

### Menu 2 – Intermediate OPEN position

Parameter indicator flashes -> Press the hand transmitter button -> Hand transmitter display also flashes -> The function has been programmed.

### Menu 3 – Intermediate CLOSE position

Parameter indicator flashes -> Press the hand transmitter button -> Hand transmitter display also flashes -> The function has been programmed.

### Menu 4 – OPEN

Parameter indicator flashes -> Press the hand transmitter button -> Hand transmitter display also flashes -> The function has been programmed.

### Menu 5 – CLOSE

Parameter indicator flashes -> Press the hand transmitter button -> Hand transmitter display also flashes -> The function has been programmed.

## Level 4 – Remote programming

### Menu 8 – Operator lighting ON / OFF

Parameter indicator flashes -> Press the hand transmitter button -> Hand transmitter display also flashes -> The function has been programmed.  
The "Radio remote control" function must not be programmed.  
→ „Level 1, Menu 7 - Relay output“

## Level 5 – Special functions

Programming of the special functions is dependent on terminal block XB03.

→ „4.3.3 Terminal block XB03“

### Menu 1 – Programmable impulse input (terminal 1/2)

1	 Impulse (normally open contact only)
2	Closing prevention device (normally open contact only)
3	Stops and reverses (only in the CLOSE direction – normally closed contact only)
4	Stops and reverses (only in the CLOSE direction – normally open contact only)
5	OPEN impulse (induction loop – normally open contact only)
6	Earlier closing possible by pressing the buttons on the input device or hand transmitter > 2 seconds
7	Impulse (normally open contact only) with permanent 24 V DC / max. 50 mA power supply

### Menu 3 – Programmable input (XW81)

1	 Impulse (normally open contact only)
2	Impulse RC (normally open contact only)
3	Closing prevention device (normally open contact only)
4	Stops and reverses (only in the CLOSE direction – normally closed contact only)
5	Stops and reverses (only in the CLOSE direction – normally open contact only)
6	OPEN impulse (normally open contact only)
7	Stop (normally closed contact only)
8	Earlier closing possible by pressing the buttons on the input device or hand transmitter > 2 seconds
9	Automatic closing timer ON / OFF

### Menu 4 – Lighting duration

2 – 250 seconds.  
 3.0 (180 seconds)

## Level 5 – Special functions

### Menu 5 – Hand-held programming device

1	 Operation and programming option
2	Operation only

### Menu 7 – Battery back-up

1	 Battery back-up deactivated
2	Battery back-up active

## Level 6 – Variable speed

### Menu 1 – OPEN speed

On a scale of 5 to 16.  
 16

### Menu 2 – Soft run OPEN speed

On a scale of 1 to 16.  
 8

### Menu 3 – Soft run OPEN position

Adjust the setting using the + (OPEN) and – (CLOSE) buttons.

### Menu 4 – CLOSE speed

On a scale of 5 to 16.  
 16

### Menu 5 – Smart run CLOSE speed

On a scale of 5 to 16.  
 8

### Menu 6 – Soft run CLOSE speed

On a scale of 1 to 16.  
 8

### Menu 7 – Smart run CLOSED position

Adjust the setting using the + (OPEN) and – (CLOSE) buttons.

### Menu 8 – Soft run CLOSE position

Adjust the setting using the + (OPEN) and – (CLOSE) buttons.

## Level 6 – Variable speed

### Menu 9 – Soft start time OPEN

1	 Soft start time 1 second
2	Soft start time 2 seconds
3	Soft start time 3 seconds
4	Soft start time 6 seconds

### Menü 10 – Soft start time CLOSE

1	 Soft start time 1 second
2	Soft start time 2 seconds
3	Soft start time 3 seconds
4	Soft start time 6 seconds

## Level 7 – Maintenance and servicing

### Menu 1 – Door cycle counter

Six-figure indicator showing the number of door operations, up to 999999.  
Figures shown one after the other up to the indicator point, then repeated.

### Menu 2 – Servicing counter

Five-figure indicator showing the number of door operations still to go, up to maintenance indication.  
Figures shown one after the other up to the indicator point, then repeated.

### Menu 3 – Servicing interval

Adjustment of the number of door operations to be completed before a servicing reminder is displayed.

1	 OFF
2	100 door operations
3	500 door operations
4	1,000 door operations
5	4,000 door operations
6	5,000 door operations
7	6,000 door operations
8	7,000 door operations
9	8,000 door operations
10	9,000 door operations
11	10,000 door operations
12	15,000 door operations
13	20,000 door operations
14	30,000 door operations
15	40,000 door operations
16	50,000 door operations

## Level 7 – Maintenance and servicing



### Menu 8 – Reset maintenance and servicing

The fault log for maintenance, diagnostics and servicing work is reset here.

1	 No reset
2	Reset the fault log

### Menu 9 – Fault indicator

Shows the current fault message.  
(No more than 16 fault messages can be viewed).

	Display the previous fault / Navigate through the list of faults
	Navigate through the list of faults

## Level 8 – System settings

Door reverses a short distance:

The operator system moves the door slightly in the opposite direction in order to release an obstacle.

Door reverses over a long distance:

The operator system moves the door all the way to the OPEN position.

### Menu 1 – Photocell

1	 Operation without photocell
2	2-wire photocell (terminal block XB03 - terminal 70/71), Door movement in CLOSE direction: door reverses over a long distance
3	External photocell (terminal block XB03 - terminal 70/71), Door movement in CLOSE direction: door reverses over a long distance

### Menu 2 – Closing edge safety device

1	 Door movement in OPEN direction: door reverses a short distance Door movement in CLOSE direction: door reverses a short distance
2	Door movement in OPEN direction: door reverses a short distance Door movement in CLOSE direction: door reverses over a long distance
3	Door movement in OPEN direction: door reverses over a long distance Door movement in CLOSE direction: door reverses over a long distance
4	Door movement in OPEN direction: door reverses over a long distance Door movement in CLOSE direction: door reverses over a long distance

## Level 8 – System settings

### Menu 3 – Automatic cut-out function

1	 Door movement in OPEN direction: door stops Door movement in CLOSE direction: door reverses a short distance
2	Door movement in OPEN direction: door reverses a short distance Door movement in CLOSE direction: door reverses a short distance
3	Door movement in OPEN direction: door stops Door movement in CLOSE direction: door reverses a short distance
4	Door movement in OPEN direction: door reverses over a long distance Door movement in CLOSE direction: door reverses over a long distance
5	Door movement in OPEN direction: door reverses a short distance Door movement in CLOSE direction: door reverses over a long distance

### Menu 4 – Operating modes

1	Door movement in OPEN direction: Deadman Door movement in CLOSE direction: Deadman
2	Door movement in OPEN direction: Press-and-release Door movement in CLOSE direction: Deadman
3	Door movement in OPEN direction: Deadman Door movement in CLOSE direction: Press-and-release
4	 Door movement in OPEN direction: Press-and-release Door movement in CLOSE direction: Press-and-release

### Menu 5 – Function of the direction command transmitters

1	Direction command transmitters not activated: The direction command transmitters trigger a command only when the door is stationary.
2	 Direction command transmitters, STOP only: A moving door is stopped by every direction command transmitter.

## Level 8 – System settings

### Menu 6 – Function of the impulse command transmitters

1	Impulse command transmitters not activated: The impulse command transmitters trigger a command only when the door is stationary.
2	Impulse command transmitters, STOP only, then standard sequence: A moving door is stopped by every impulse command transmitter. A subsequent command will start the operator system moving in the opposite direction. (OPEN - STOP - CLOSE - STOP - OPEN).
3	 Impulse command transmitters, STOP only, then standard sequence: A moving door is stopped by every impulse command transmitter. A subsequent command will start the operator system moving in the opposite direction (OPEN - STOP - CLOSE - STOP - OPEN). With automatic closing, there is no STOP in the OPEN direction.

### Menu 7 – Stress relief in the CLOSED door position (back jump)

1	 Back jump not activated
2	Back jump activated – short
3	Back jump activated – medium
4	Back jump activated – long

### Menu 8 – Direction of rotation

1	 Standard
2	Reversed direction of rotation

### Menu 9 – Changing the display language

The plain text display can be set to 16 different languages.

1	 German
2	English
3	French
4	Dutch
5	Italian
6	Spanish
7	Czech
8	Russian
9	Polish
10	Norwegian
11	Swedish
12	...
13	...
14	...
15	...
16	...

## Level 8 – System settings

### Menu 10 – Position of the door-frame photocell

The position of the door-frame photocell can be manually adjusted if required.

Adjust the setting with + (OPEN) and – (CLOSE) button.

## 6. Operation

### WARNING!

#### Danger of injury due to uncontrolled operation of the door!

- Operate the controls or the hand transmitter only when there are no persons or objects in the path of the door.
- Ensure that the controls and the hand transmitter are never used by children or unauthorised persons.
- Ensure that the hand transmitter cannot be operated by accident (in a trouser pocket, for example).

### NOTICE

#### Danger of damage to property due to uncontrolled movement of the door!









When the door moves, the hand chain can get caught and this could result in damage (in the case of ceiling-mounted supports for example).

- Ensure that there are no obstacles blocking the path of the door or the hand chain.

### 6.1 Hand transmitter

The operator works with the supplied hand transmitter on the basis of a pulse sequence control system.

#### Operating the door using the hand transmitter

1.		The control system is in operating mode.	
2.		1. Impulse: The door opens and moves in the OPEN direction	
3.		2. Impulse. The operator system stops.	
4.		3. Impulse: The door moves in the opposite direction (CLOSE direction).	

Transmitting the code (only multi-bit)		
1.		Connect the hand transmitter to the transmission plug.
<b>Always push the MASTER remote button first then the other remote</b>		
2.		Press the button on the master transmitter. Keep the button pressed. The LED lights up.
3.		Press the button on the hand transmitter which is to be given a new code. The LED flashes.
4.		The LED lights up. The coding procedure is completed.
5.		Remove the transmission plug.

For multi-button transmitters, each button can be programmed with a different function.

Changing the code (only multi-bit)		
1.		Plug the transmission plug into the hand transmitter.
2.		Short-circuit one of the two outer pins with the centre pin adjacent to it (e.g. using a screw driver).
3.		Press the desired button on the hand transmitter. The LED flashes.
4.		The LED lights up. The coding procedure is completed.
5.		Remove the transmission plug.

After the hand transmitter has been re-coded, the operator system must also be re-programmed to respond to the new code.  
For multi-channel transmitters, the programming process must be carried out for each button separately.

#### Changing the battery

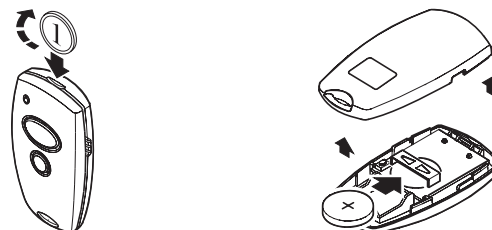

#### Attach sun visor clip

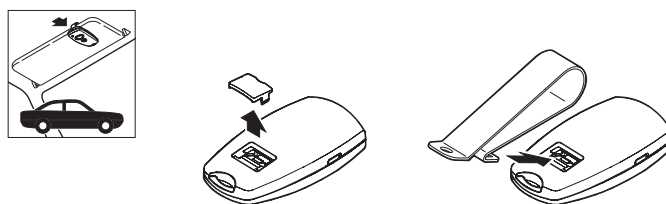

#### REFERENCE

For more information on the additional functions of the bi-linked hand transmitter supplied, please refer to the relevant documentation.

## 6.2 Release mechanism

### ⚠ CAUTION!

#### Danger of injury due to uncontrolled movement of the door!

When the release mechanism is operated, uncontrolled door movements could occur:

- If the door springs are weak or broken.
- If the door is not balanced.
- When the mechanism is released, only move the door carefully and at a moderate speed!

### 👉 NOTICE

#### Danger of damage to property due to uncontrolled movement of the door!

When opening the door manually, the carriage could collide with the carriage stop.

- When the mechanism is released, only move the door carefully and at a moderate speed!

6.2 / 1

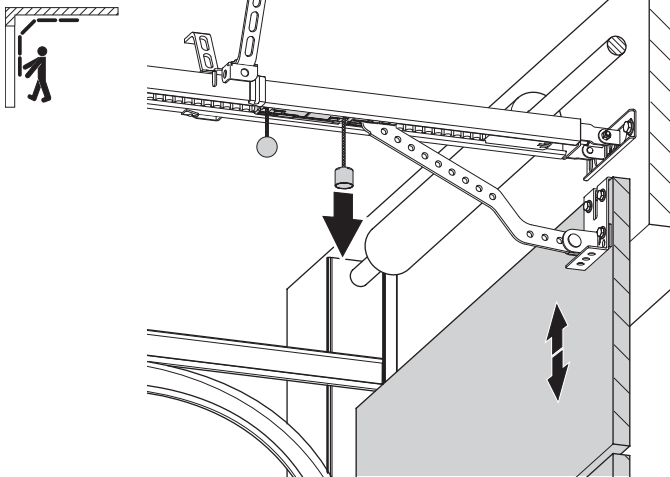

6.2 / 2

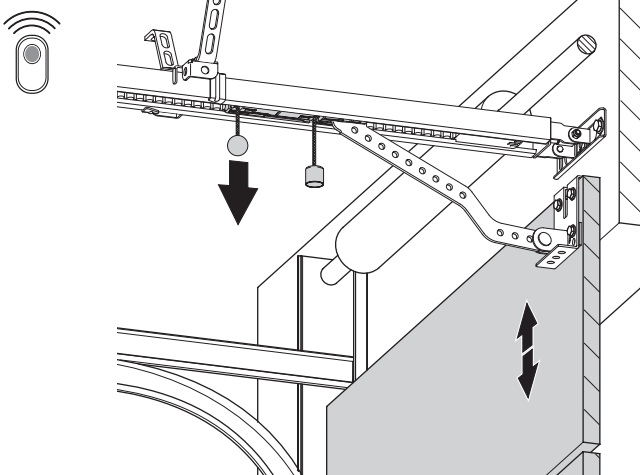

## 7. Maintenance

To ensure fault-free operation, the door system must be inspected regularly and, if necessary, be repaired. Before starting work on the door system, the operator system must always be disconnected from the power supply.

- Check once a month that the operator system reverses when the door touches an obstacle. To check this, place an obstacle, 50 mm in height, in the path of the door in the direction of travel.
  - Check the settings of the automatic cut-out in the OPEN and CLOSE directions.
- „5.5.2 Checking the automatic cut-out“
- Check all the moving parts of the door system and door operator system.
  - Check the door system for signs of damage or wear and tear.
  - Move the door manually to check that the door travels easily and smoothly.

### Care and cleaning

### ⚠ DANGER!

#### Life-threatening danger due to electric shock!

- It is vital that you disconnect the operator system from the power supply before cleaning. Take measures to ensure that the power supply remains disconnected for the duration of the cleaning operation.

### 👉 NOTICE

#### Damage resulting from incorrect operation!

When cleaning the operator system, never use:

- direct water jets, high pressure cleaners, acids or alkaline solutions.
- Clean the outside of the housing using a damp, soft cloth that does not shed fibres.

If particularly dirty, the housing can be cleaned using a mild detergent.

## 8. Disassembly

### ⚠ DANGER!

#### Life-threatening danger due to electric shock!

- It is vital that you disconnect the operator system from the power supply before disassembly. Take measures to ensure that the power supply remains disconnected during disassembly.

### ⚠ WARNING!

#### Possibility of serious injury due to falling components!

- Before disassembling the operator system, secure it to prevent it from falling.
- Observe all the applicable health and safety regulations.

The system must be disassembled by a qualified technician, following the installation instructions in reverse.

## 9. Disposal

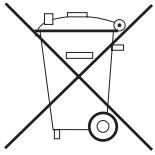

Do not dispose of old equipment or batteries with the normal household waste!

- Dispose of old devices at a waste collection centre for electronic waste or via your specialist dealer.
- Dispose of old batteries in a battery recycling container or via a specialist dealer.
- Dispose of the packaging material in the special waste collection containers for paper, cardboard and plastic.

## 10. Rectifying faults

### Faults with no fault messages

#### LCD display does not light up or display information.

No supply voltage present.

- Check that the mains voltage supply is operational.
- Check the electrical connection.

The thermal overload protection in the mains transformer has been triggered.

- Allow the transformer to cool down.

Control unit defective.

- Have the operator system checked.

#### No reaction after impulse signal.

Connection terminals for "impulse" button are bridged, e.g. due to flat terminals or a short circuit in the wiring.

- If key switches or interior push buttons are connected, try disconnecting them from the control unit: remove cables from the XB03 terminal block, insert the shorting plug and search for the wiring fault.

→ „4.3.3 Terminal block XB03“

### Faults with no fault messages

#### No reaction after an impulse signal has been transmitted by the hand transmitter.

Modular antenna is not plugged in.

- Connect the modular antenna to the control unit.
- „4.4 Completing the installation“

Hand transmitter code does not correspond to the receiver code.

- Activate the hand transmitter anew.

→ „5.4 Express programming“

The battery in the hand transmitter is empty.

- Insert new battery.

→ „6.1 Hand transmitter“

Remote control deactivated ("external button" symbol flashes).

- Reactivate remote control by pressing + (OPEN) or – (CLOSE) button on the operator.

The hand transmitter, control electronics or modular antenna are defective.

- Have all 3 components checked.

#### The operator system reverses when the door-frame photocell is triggered.

The system was not programmed correctly.

The door-frame photocell was not recognised correctly.

- Adjust the position of the door-frame photocell manually.

→ „Level 8, Menu 10 – Position of the door-frame photocell“

#### Short or no range.

- Hand transmitter faulty.
- Check hand transmitter and replace if necessary.

Antenna faulty or incorrectly installed.

- Check/replace antenna.
- Move the antenna to the lintel or outside the garage; if necessary install outdoor antenna.

Interference on the frequency band used.

- Set to alternative frequency.

#### Operator lighting does not work.

Light bulb broken.

- Replace LED.

#### In case of other faults.

- Note the error message (see LCD display).
- Have article no., production no. and revision status (see rating plate) ready for queries.
- Instructions for resetting and putting back into operation are given in the installation instructions.

## Faults with fault messages

The system indicates recognised faults by showing a fault number (example: fault number 7). The control system switches to reporting mode. In operating mode, the last fault number can be shown by pressing the P button.

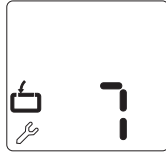

### Fault number 7

Programming mode will end automatically if 120 seconds elapse without a button being pressed.

- Start the programming procedure again.

### Fault number 9

Rotational speed sensor impulse not present, operator system is obstructed.

- Have the operator system checked.

### Fault number 10

The door does not move easily or is obstructed.

- Take measures to ensure that the door moves freely and smoothly.

The maximum driving power has been set too low.

- Have the maximum driving power checked by a specialist dealer.

→ „Level 2, Menu 1 - Driving power required to OPEN“

→ „Level 2, Menu 2 - Driving power required to CLOSE“

### Fault number 11

Excess travel stop.

- Have the operator system checked.

### Fault number 15

Photocell triggered or defective.

- Remove obstacle or have the photocell checked.

Photocell programmed but not connected.

- Deactivate or connect the photocell.

### Fault number 16

The current sensor for the automatic cut-out is defective.

- Have the motor unit checked.

### Fault number 26

The operator system is overloaded when the driving power is set to 16 (maximum).

- Have the external power supply checked.

## Faults with fault messages

### Fault number 28

The door does not move easily or smoothly or is obstructed.

- Check the door movement and take measures to ensure that the door moves freely and smoothly.

Automatic cut-out setting is too sensitive.

- Have the automatic cut-out function checked by a specialist dealer.

→ „Level 2, Menu 3 – Automatic cut-out in the OPEN direction“

→ „Level 2, Menu 4 – Automatic cut-out in the CLOSE direction“

### Fault number 30

MS bus fault.

- Reset the bus modules.

→ „Level 1, Menu 8 – RESET“

- Have the connected bus modules checked.

### Fault number 33

Rise in temperature due to overheating.

- Allow the motor unit to cool down.

### Fault number 35

Electronic defect.

- Have the operator system checked.

### Fault number 36

This fault number can also be triggered by an expansion module if connected.

Stop button function programmed, but no stop button connected.

- Connect stop button.

→ „4.3 Connection of control elements“

- If there is no stop button available, carry out a “Safety equipment reset” or a “BUS module reset”.

→ „Level 1, Menu 8 – RESET“

### Fault number 48

The door does not move easily or smoothly or is obstructed.

- Check the door movement and take measures to ensure that the door moves freely and smoothly.

The CLOSED door position has not been set correctly.

- Check and, if necessary, reset the OPEN and CLOSED door positions.

- Check the door.

# 11. Appendix

## 11.1 Technical Data

### Electrical data

Rated voltage, regional deviations are possible	V	230 / 260
Rated frequency	Hz	50 / 60
Current input	A	1.1
Power consumption in operation*	kW	0.25
Power consumption in standby*		
– Comfort 260		approx. 4
– Comfort 270		approx. 4
– Comfort 280	W	approx. 4
– Comfort 260 BL		approx. 0.6
– Comfort 270 BL		approx. 0.6
– Comfort 280 BL		approx. 0.6
Duty cycle	min.	short-term 2
Control voltage	V DC	24
Protection category of motor unit		IP 20
Protection class		II

\* without any additional equipment connected

### Mechanical data

Max. push and pull force		
– Comfort 260		550
– Comfort 270	N	750
– Comfort 280		1,000
Max. travel speed	mm/s	160
Opening time, dependent on door type	s	approx. 14

### Environmental data

Dimensions of the operator system

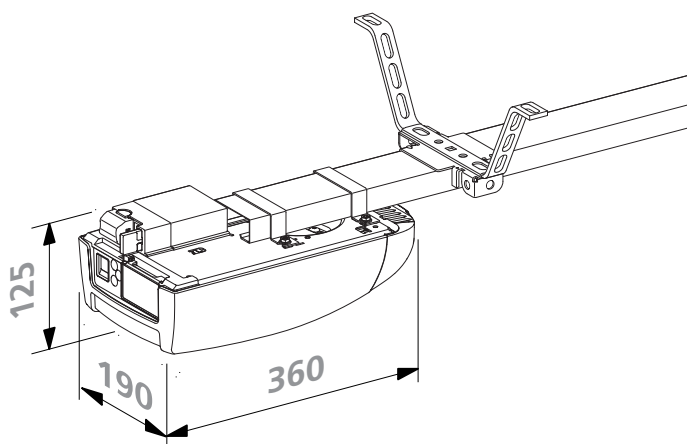

Weight (total)		
– Comfort 260		6.4
– Comfort 270	kg	6.5
– Comfort 280		6.6
Sound pressure level	dB(A)	< 70

### Environmental data

Temperature range		°C	-20
		°C	+60

### Areas of application

#### Comfort

		260	270	280
Up-and-over doors				
– max. door width	mm	3,500	5,000	6,000
– max. door weight	kg	90	165	200
Sectional doors with single-wall door leaf				
– max. door width	mm	5,000	5,500	6,000
– max. door weight	kg	90	165	200
Sectional doors with double-wall door leaf				
– max. door width	mm	3,000	5,500	6,000
– max. door weight	kg	90	165	200
Retractable up-and-over doors and canopy doors				
– max. door width	mm	3,500	5,000	6,000
– max. door height	mm	2,250	2,250	2,250
– max. door weight	kg	90	165	200
Max. cycles	per day	16	28	48
Suitable for operator booms with				
– roller chain		x	x	x
– toothed drive belt		x	x	x
– ball chain		x	–	–

## 11.2 Declaration of Incorporation

We hereby declare that in its design and construction, and in the form as delivered, the product mentioned below complies with the relevant basic requirements of the EC Machinery Directive (2006/42/EC).

This declaration shall no longer be valid if changes are made to the product without our authorisation.

**Product: Garage door operator Comfort 260, 270, 280**  
**Revision status: R01, R10**

In addition, the partly completed machinery is in conformity with all regulations of the EU Construction Products Regulation No. 305/2011, the Electromagnetic Compatibility Directive 2004/108/EC and the Low Voltage Directive 2006/95/EC.

- Machinery Directive 2006/42/EC  
Health and safety requirements applied according to Annex 1:  
General principles No. 1 No. 1.1.2, 1.1.3, 1.1.5, 1.2.1, 1.2.2, 1.2.3, 1.2.6, 1.3.1, 1.3.4, 1.3.7, 1.3.8, 1.3.9, 1.5.1, 1.5.4, 1.5.6, 1.5.8, 1.5.14, 1.7  
  
EN 60204-1:2006  
EN ISO 12100:2010  
EN ISO 13849-1:2008  
Cat. 2 / PLC for the functions of power limitation and end position detection
- EMC electromagnetic compatibility 2004/108/EC  
EN 55014-1:2006  
EN 61000-3-2:2008  
EN 61000-3-3:2008  
EN 61000-6-2:2005  
EN 61000-6-3:2007
- Low voltage directive 2006/95/EC  
EN 60335-1:2002  
EN 60335-2-95:2004

The relevant technical documentation is compiled in accordance with Annex VII(B) of the Machinery Directive 2006/42/EC. We undertake to transmit, in response to a reasoned request by the market surveillance authorities, this information in electronic form within a reasonable term.

The machinery is incomplete and must not be put into service until the machinery into which it is to be incorporated has been declared in conformity with the provisions of the Machinery Directive 2006/42/EC.



02.10.2014

M. Hörmann  
Management



Person authorised to compile the relevant technical documentation:  
Marantec Antriebs- und Steuerungstechnik  
GmbH & Co. KG  
Remser Brook 11 · 33428 Marienfeld · Germany

Phone: +49 5247 705-0

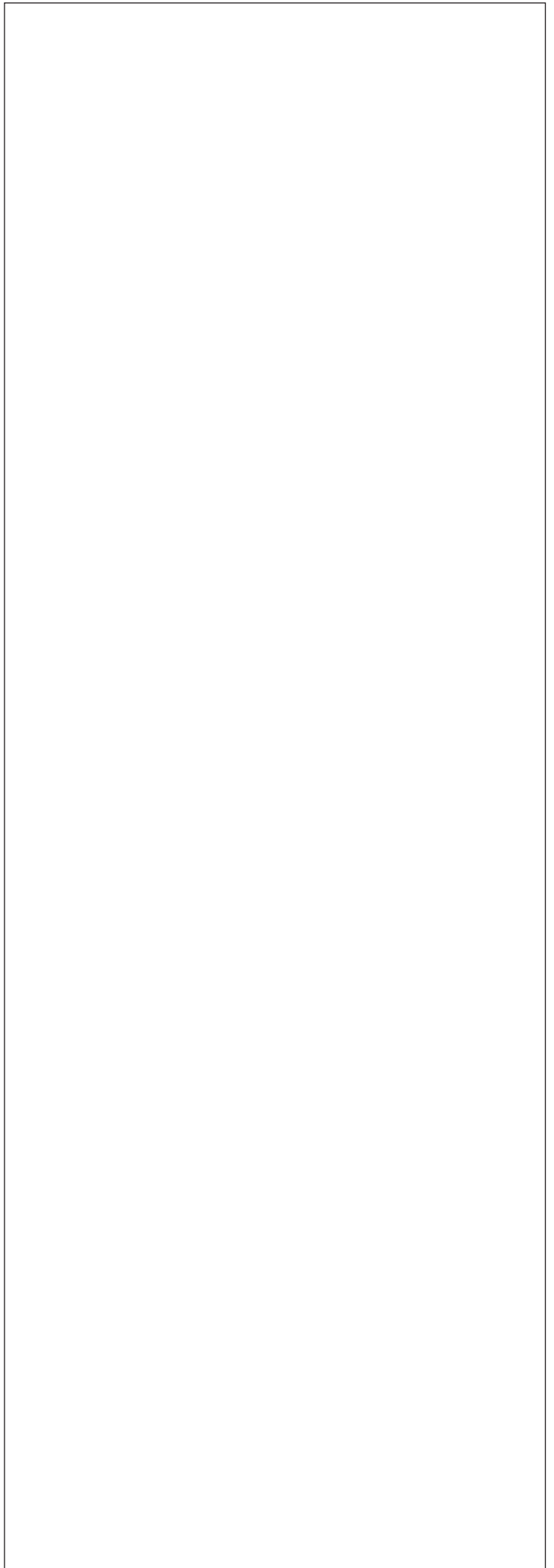
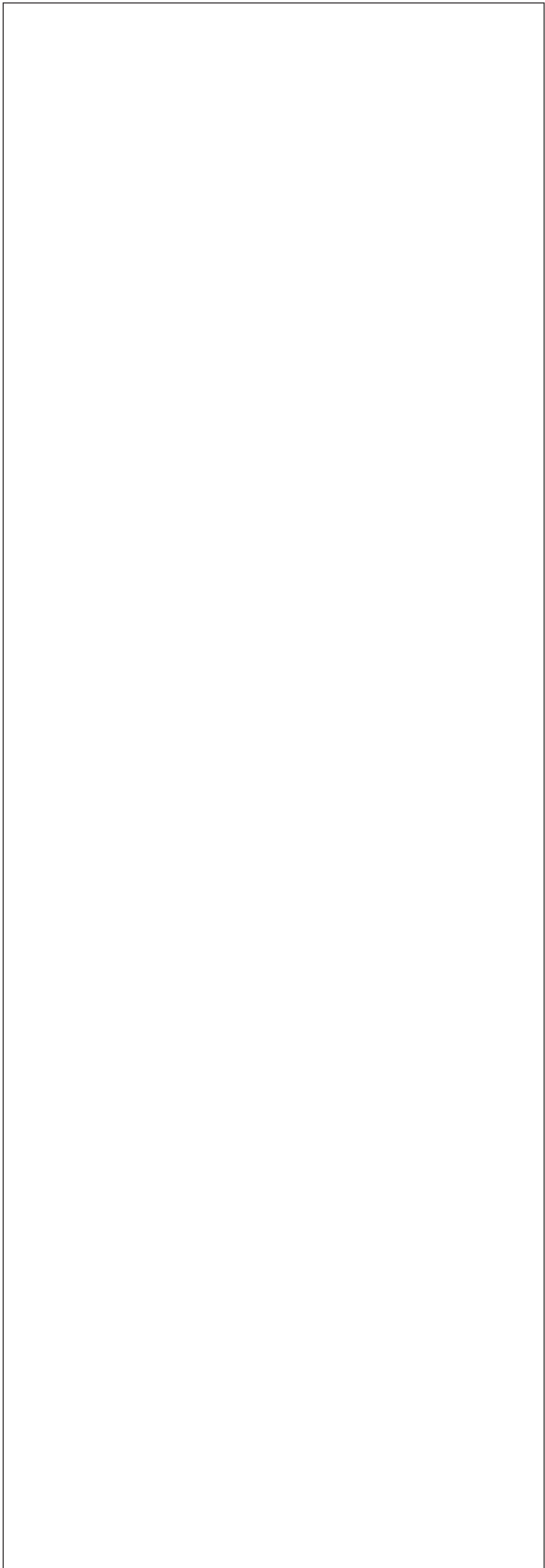

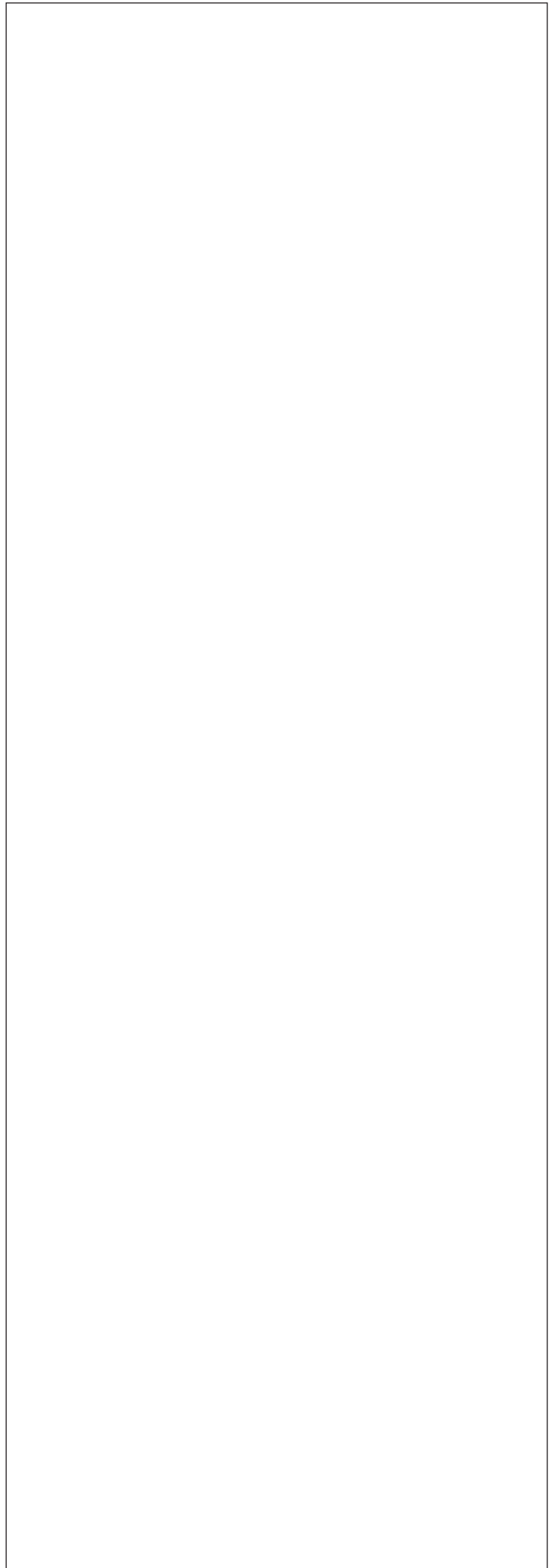
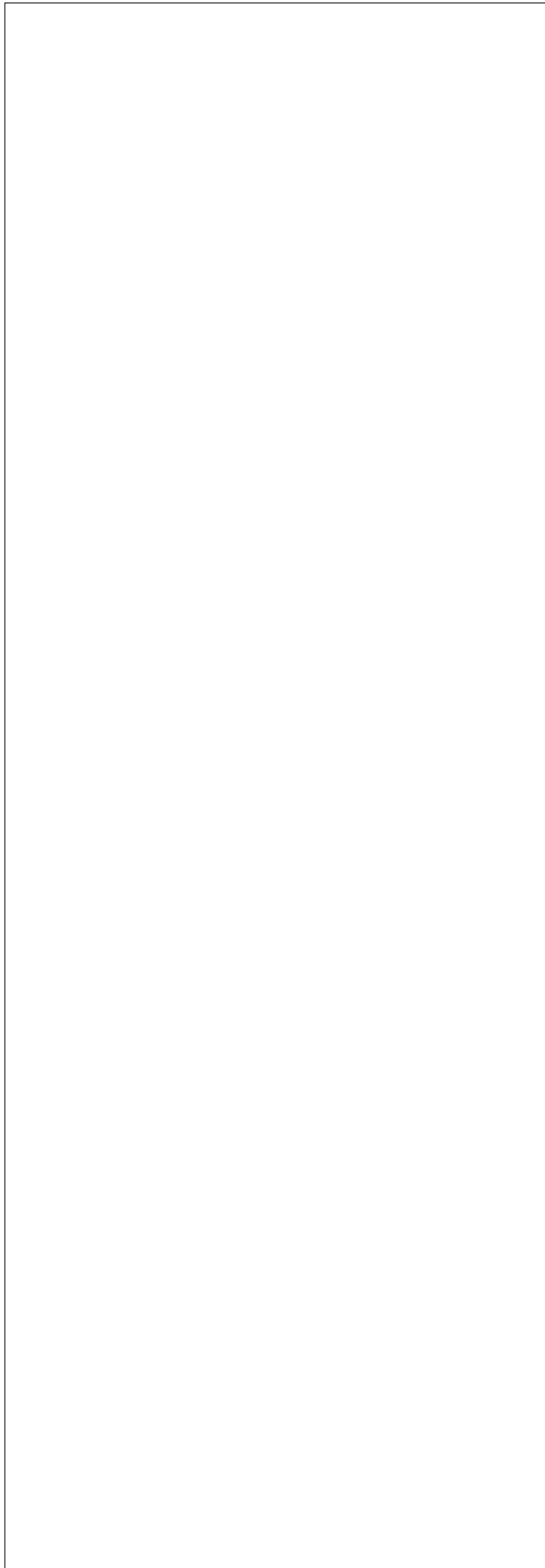

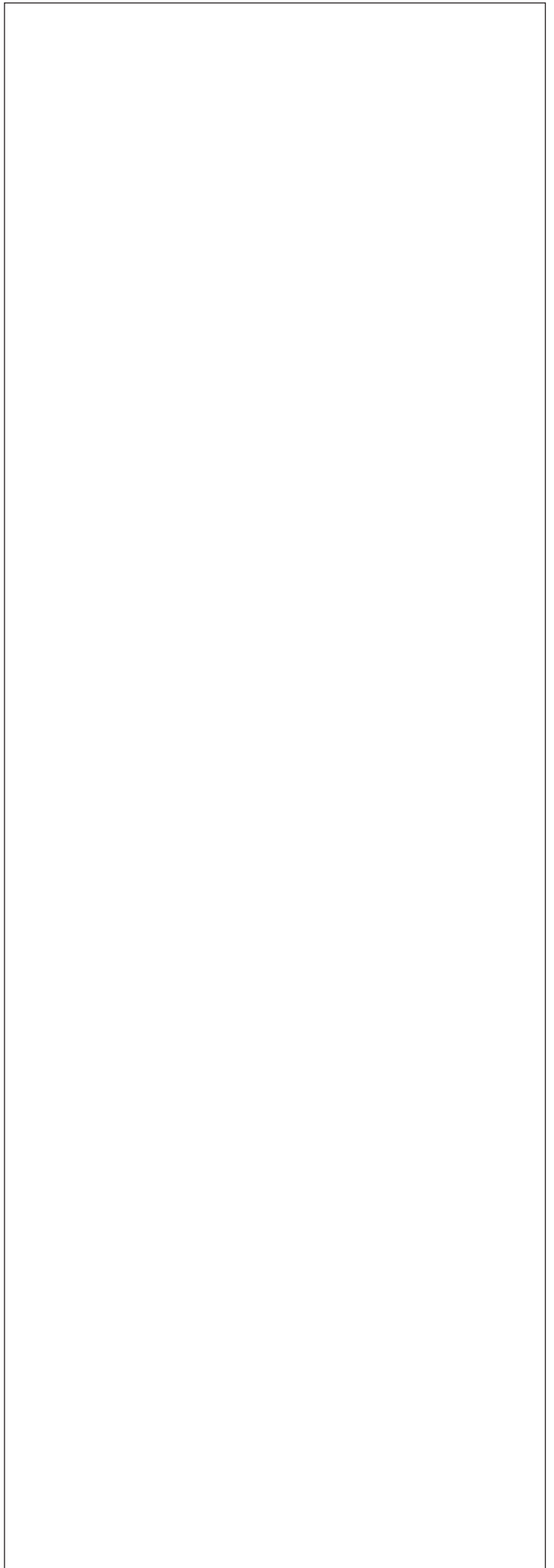
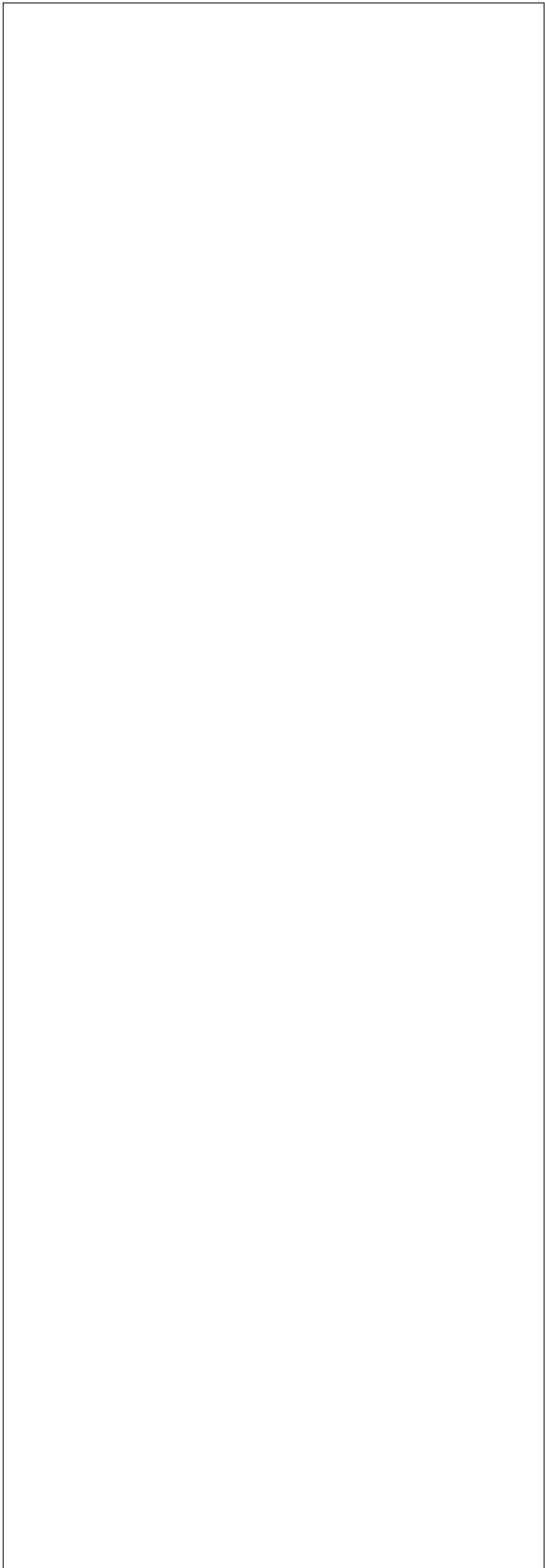

Type plate

Typ (A)	_____
Rev (B)	_____
Art. No. (C)	_____
Prod. No. (D)	_____

