

GRIFCO®

eDrive

+*2.0*

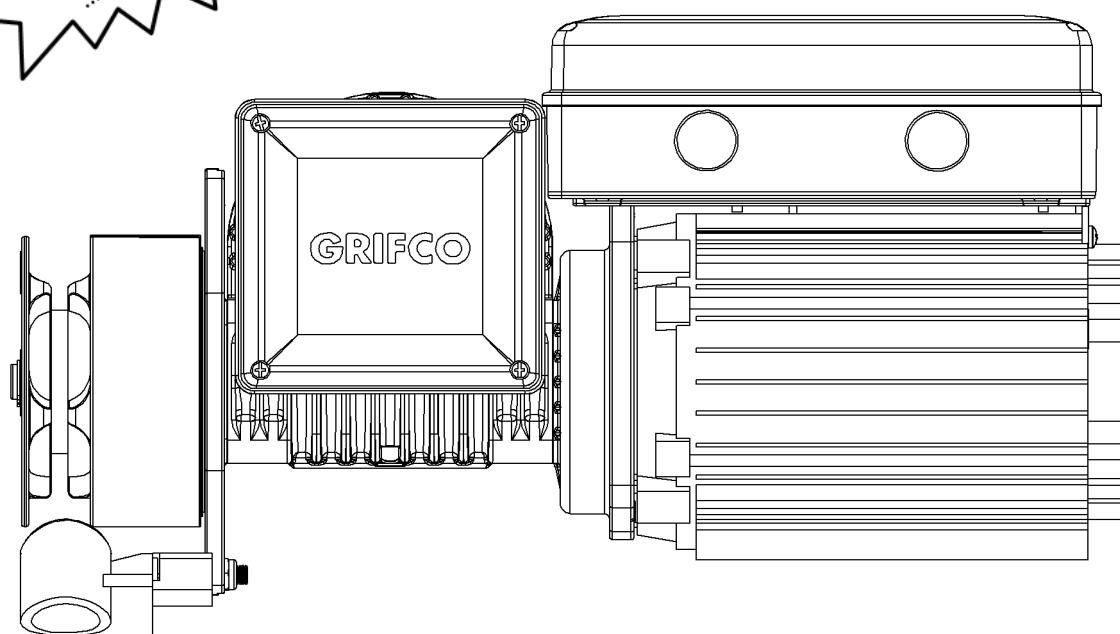

installation and users
manual for eDrive +2.0
commercial door opener

www.grifco.com.au
www.grifco.co.nz

Chamberlain Australia Pty Ltd
PO Box 1446, Lane Cove
NSW 1595, Australia
Phone toll free 1800 474 326

Chamberlain New Zealand Ltd
PO Box 100-221
North Shore 0745, New Zealand
Phone toll free 0800 653 667

Safety Symbol and Signal Word review

This commercial door opener has been designed and tested to offer safe service provided it is installed, operated, maintained and tested in strict accordance with the instructions and warnings contained in this manual.



Mechanical



Electrical

CAUTION

When you see these Safety Symbols and Signal Words on the following pages, they will alert you to the possibility of serious injury or death if you do not comply with the warnings that accompany them. The hazard may come from something mechanical or from electric shock.

When you see this Signal Word on the following pages, it will alert you to the possibility of damage to your commercial door and/or the commercial door opener if you do not comply with the cautionary statements that accompany it.

THESE ARE IMPORTANT SAFETY INSTRUCTIONS. FOLLOW ALL INSTRUCTIONS AS INCORRECT INSTALLATION CAN LEAD TO SEVERE INJURY OR DEATH



Keep commercial door balanced. Sticking or binding doors must be repaired. Commercial doors, door springs, pulleys, brackets and their hardware are under extreme tension and can cause serious personal injury. **Do not attempt to loosen, move or adjust them.** Call for commercial door service.



Permanently fasten all supplied **labels** adjacent to the wall control as a convenient reference and reminder of safe operating procedures.



Do not wear rings, watches or loose clothing while installing or servicing a commercial door opener.



Disengage all existing commercial door locks to avoid damage to commercial door. Install the wall control (or any additional push buttons) **in a location where the commercial door is visible during operation . Do not allow children to operate push button(s) or remote control(s).** Serious personal injury from a closing commercial door may result from misuse of the opener.



To avoid serious personal injury from entanglement, **remove all ropes connected to the commercial door** before installing the door opener.



Activate opener only when the door is in full view, free of obstructions and opener is properly adjusted. No one should enter or leave the building while the door is in motion.



Installation and wiring must be in compliance with your local building and electrical codes. **Connect the power supply cord only to properly earthed mains.**



An electrician must disconnect electric power to the commercial door opener before making repairs or removing covers.



Moisture and water can destroy the electronic components. Make sure under all circumstances that water moisture or storage moisture cannot penetrate the electronics. The same applies for openings and cable entries.



The actuating member of a biased-off switch is to be located within direct sight of the door but away from moving parts. **Unless it is key operated,** it is to be installed at a minimum height of 1500mm and **not accessible to the public.**



After the installation a final test of the full function of the system and the full function of the safety devices must be done.



Make sure that people who install, maintain or operate the door follow these instructions. Keep these instructions in a safe place so that you can refer to them quickly when you need to.



When operating a biased-off switch, make sure that other persons are kept away.



This appliance is not intended for use by persons (including children) with reduced physical, sensory or mental capabilities, or lack of experience and knowledge, unless they have been given supervision or instruction concerning use of the appliance by a person responsible for their safety. Children should be supervised to ensure that they do not play with the appliance.



The opener cannot be used with a driven part incorporating a wicket door (unless the opener cannot be operated with the wicket door open).



If the opener is installed at a height less than 2.5 metres from floor level or any other level from which the unit can be accessed (eg mezzanine) the installer is responsible to fit guards to the opener to prevent access to the chain drive.



Motor may become hot during operation. Appropriate clearance and/or shielding should be supplied by the installer to ensure any cabling, wiring and/or other items cannot come in contact with the motor. If temperature rise exceeds 50°C all fixed wiring insulation must be protected, for example, by insulating sleeving having an appropriate temperature rating.



Use the commercial door opener for its intended purpose. eDrive +2.0 openers are designed for operating spring balanced roller shutters, spring balanced roller doors and counterweighted bi-fold and vertical lift doors.



WARNING: Important safety instructions. It is important for the safety of persons to follow all instructions. SAVE these instructions.

TABLE OF CONTENTS

Safety instructions	2
Introduction	4
Identifying your eDrive +2.0	4
Planning	5
Installation	6-10
• Mounting the unit	6-7
• Installing hand chain	8
• Connecting power	9
• Controller	10
• Installing controller	10
• ACEM	10
Setup and adjustment	11-13
• Checking power	11
• Door direction	11
• Changing door direction	11
• Setting Limits	12
• Optional third limit	13
Operation	13
Door behaviour and Entrapment Protection inputs	14-15
• Door behaviour modes	14
• Setting door behaviour	14
• Installing Entrapment Protection Devices	15
• Additional switchgear / Accessories	15
• Toggle Input (2 wire)	15
Typical Car Park Application (example)	16
Main Control Board (MCB) layout	17
Accessories	18
• Forklift/Wall Remote	18
• 3 Button Key Ring Remote	18
• Wireless Wall Control	18
• Wireless Keypad	18
• Infrared (IR) Reflective Beam	18
• STAR1000EVO Transmitter Management System	18
• Auto Close & Wireless Accessory set up	19-20
• Maintenance	21
• Troubleshooting	22-23
• Warranty	24

INTRODUCTION

Congratulations on your purchase of the Grifco® eDrive +2.0 Commercial Door Opener. The eDrive +2.0 is a state-of-the-art opener using sophisticated digital electronics and robust mechanical gearing that provides a balance of user friendly operation and high level technology, coupled with exciting new standard features.

New standard features include:

Radio on Board

With Radio on Board as standard, the new eDrive +2.0 no longer requires an additional Receiver Card for wireless accessory connectivity.

Auto Close

A built-in Auto Close feature can now be enabled with up to 10 - 300 seconds delay, adjustable in 10 second increments.

Quick Connect Easy Plug-in Terminal

eDrive +2.0 now features more robust pluggable terminal blocks making installation of Entrapment Protection and other devices easier.

Toggle Input Grifco® eDrive +2.0 features a two-wire quick connect plug-in toggle input which allows direct connection of an external devices such as a single button open/close control and access control devices (such as card readers, keypads, key switches and loop detectors etc.).

Wireless Security Keypad Ready

Simply mount the wireless keypad to the wall to provide;

- wireless security access
- wireless hold to close

IDENTIFYING YOUR eDrive +2.0

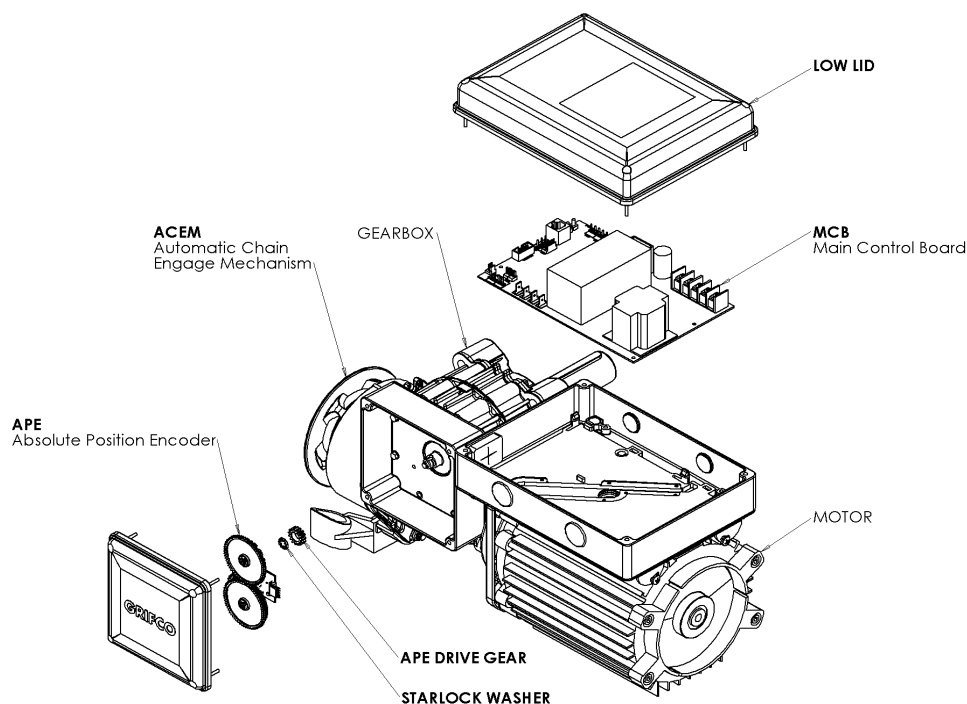

Appearance may vary with different motor, gearbox and controller types

- Your standard eDrive +2.0 includes the opener, mounting bolts, and controller (containing controller cable and conduit entries).
- Some optional accessories may also be included such as a mounting plate, sprockets, chain, beams & transmitter.

CAUTION

Please remove any locks fitted to the door before operation in order to prevent damage to the door.

WARNING

Make sure that people who install, maintain or operate the door follow these instructions. It is advised that the instruction be kept in a safe place so that you can refer to them quickly when you need to.

PLANNING

Identify the type and dimensions of your commercial rolling door. A check of the application is recommended to ensure suitability of the opener model to the door.

Installer is to check that the temperature range marked on the drive is suitable for the location.

Opener Build	Rated Load (Nm)	Hp	Duty Rating (%)	Phase	Door size (m ²)*	kW	Amp	Max Door Mass (KG)**
ML5053	53	0.5	10	3	18	0.37	1.6	270
ML5103	140	1.0	10	3	36	0.75	2.4	540
MH5103	80	1.0	30	3	30	0.75	2.0	450
ML5153	190	1.5	10	3	50	1.1	2.9	890
ML5051	67	0.5	10	1	18	0.37	3.5	270
ML5102	85	1.0	10	1	36	0.75	6.0	480
MH5102	73	1.0	30	1	30	0.75	4.4	450

Note: eDrive +2.0 openers are not recommended for use on residential garage doors.

* Door size is stated as a guide only. Refer to "max door mass" to assess drive suitability.

** Maximum door mass is:

- before spring balancing. Door must be spring balanced.
- based on at least 4:1 sprocket ratio, and curtain load with 200mm drum diameter.

If any conditions above are not met, some consideration should be given to increasing the sprocket ratio, or opener size. The opener should be installed on the most suitable side of the commercial door. Consider an In-Board Mounting Kit (P/N IBMK) if there is insufficient side room. Select the side that meets the requirements listed below.

- Must have minimum distance of 15mm between mounting plate and door drum sprocket (refer pg 6 image no. 1)
- Must have minimum distance of 10mm between APE housing and imposing structure (refer pg 7 image no. 4)
- Must have minimum overhead clearance of 150mm from the main control housing (refer pg 7 image no. 5)

Note: Before installing the opener, check that the commercial door is in good mechanical condition, correctly balanced and opens and closes properly.

Doors of Rigid Construction

When using a Grifco® eDrive +2.0 on commercial doors of 'rigid' construction (eg. bi-fold, vertical lift, sectional or continuous steel roller doors etc.), consider that the **limit confirmation** movement requires a 1/4 turn of the output shaft downward at the closed position (refer to page 12 for more information on how to reset the re-find movement). Sufficient mechanical freedom must be provided at the closed position for this reason.



WARNING

The door guides must be fitted with mechanical stops that prevent the bottom rail from passing through in the opening direction. The opener should stall if driven into the mechanical stops.

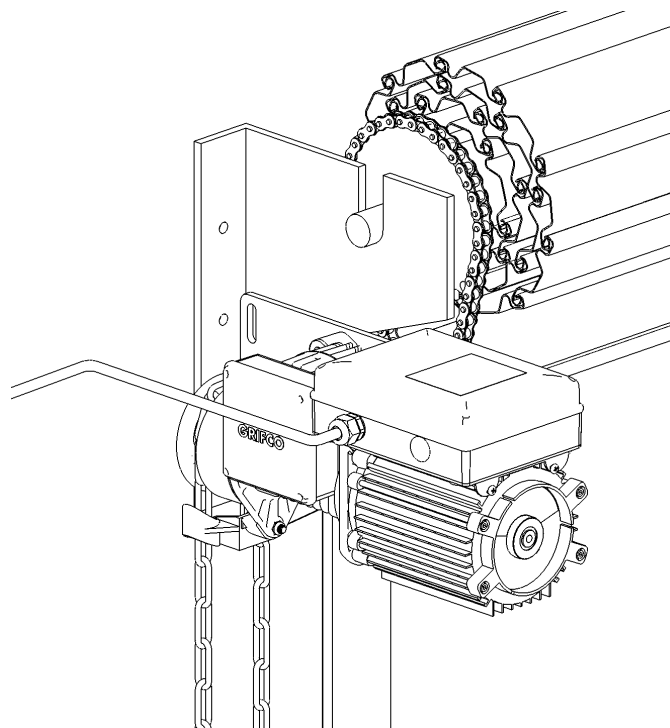

INSTALLATION SECTION

Mounting the unit

The eDrive +2.0 is typically flag mounted below the door drum so that the opener shaft points toward the door opening and lies beneath the sprocket of the door drum. For mounting you will need to either secure the opener to the roller shutter head plate with prepared holes or slots, or use a mounting plate that will need fixing via a wall angle or similar existing structure.

Note: The eDrive +2.0 is not designed to be installed upside down. The chain guide must not be repositioned.

It is strongly recommended that a suitably rated lifting strap be used to raise the opener to a necessary height, shown right. A suitable lifting device should be connected to a secure support beam (or similar) above the door axle.

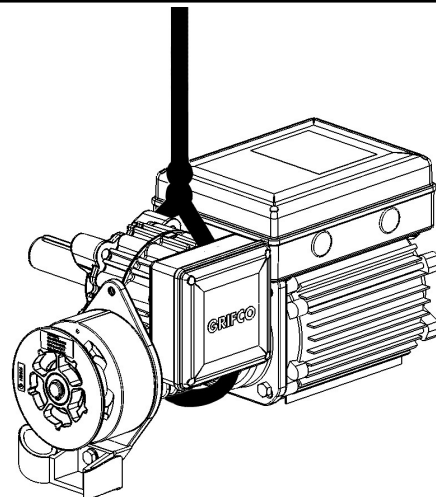

When assessing and selecting an appropriate mounting location, the following considerations should be made:

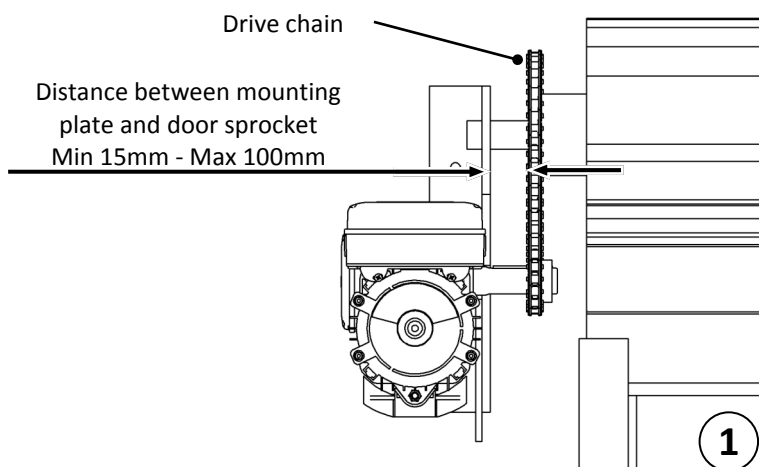

Alignment of door sprocket to output shaft of eDrive +2.0 (see left)

Mounting plate slots allow the chain tension to be adjusted through vertical movement of the opener (see right)

Mounting plate slots

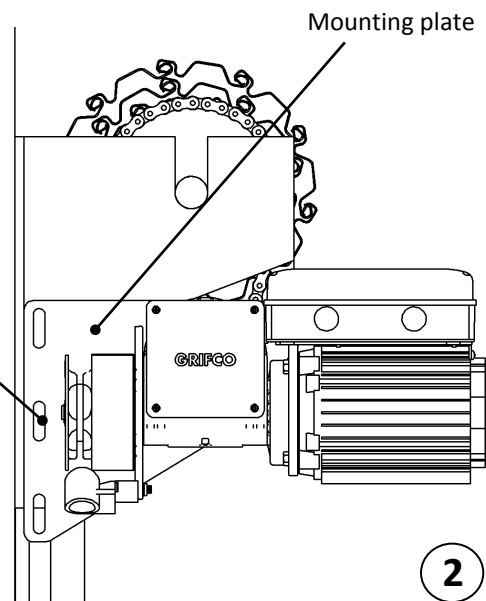

Clear path for manual chain to hang downward (refer pg 8 image no. 7 & 8)

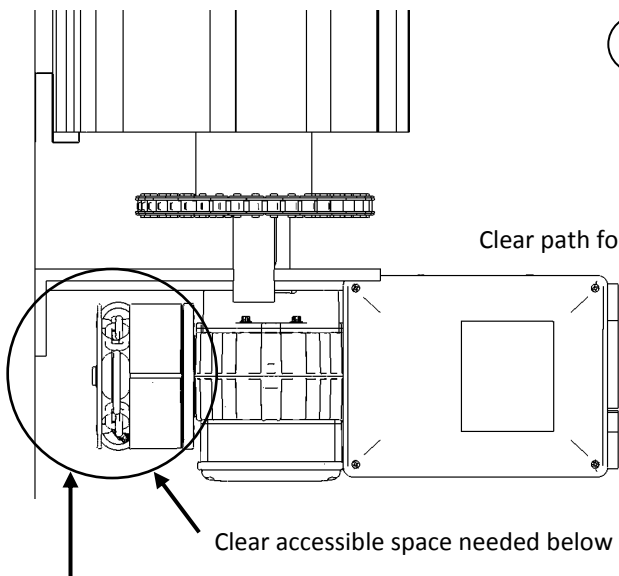

Distance between ACEM and wall 40 mm

Mounting the unit (continued)

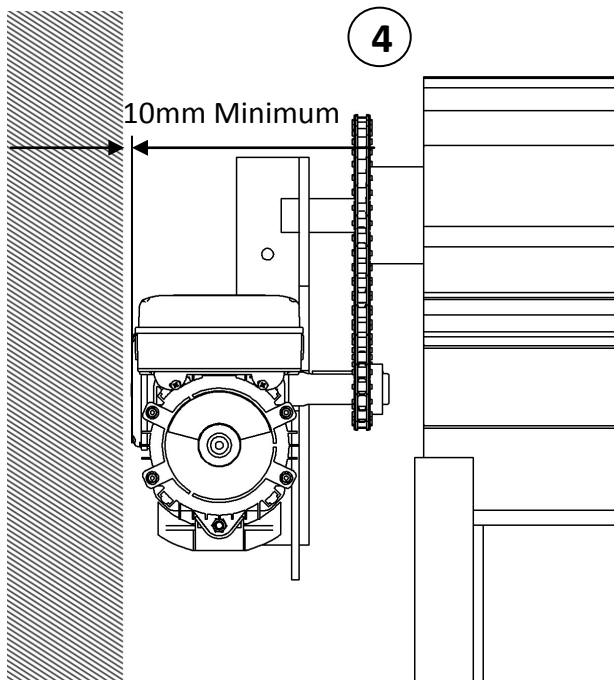

Side room to imposing structures (see left).

The eDrive +2.0 APE housing is not a serviceable area and can be located within 10mm of an imposing structure without affecting installation. Where there is insufficient side room, consider using the opposite hand opener and mount inboard with a Grifco® Inboard Mounting Kit, P/N IBMK.

Limited head room (see right).

The eDrive +2.0 main control housing is a serviceable area and will need to be accessed by service personnel. Refer below for options on how to overcome problems in which sufficient head room is not available.

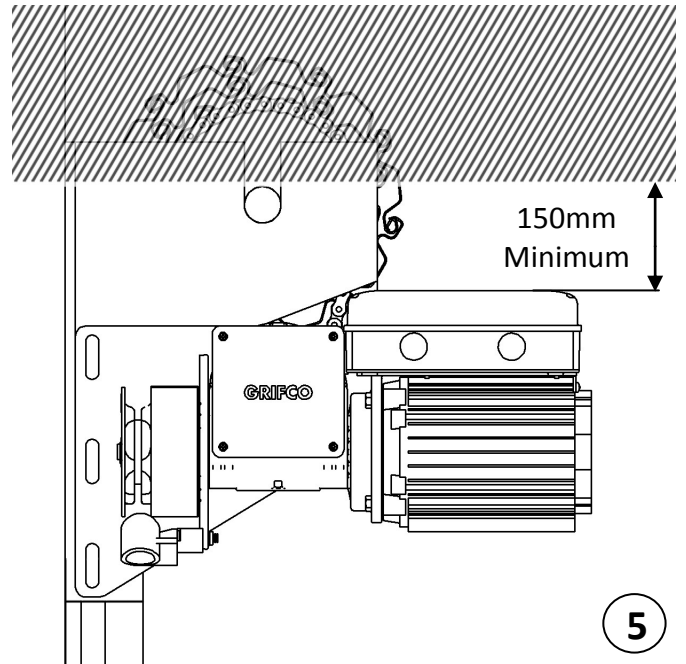

If there is insufficient head room above the eDrive +2.0 opener to allow servicing then a Grifco® Wall Mount Kit (P/N WMK2) or Grifco® Rotation Bracket (P/N RBK2) can be used to reposition the main control housing. Please contact your local dealer or Chamberlain for more information.

Location of Controller (see left).

Controller has 6 metres of cable with RJ45 ends ready to connect the eDrive +2.0 opener to the controller. eDrive +2.0 Controller Extension Kit (P/N ESK01) is available if needed.

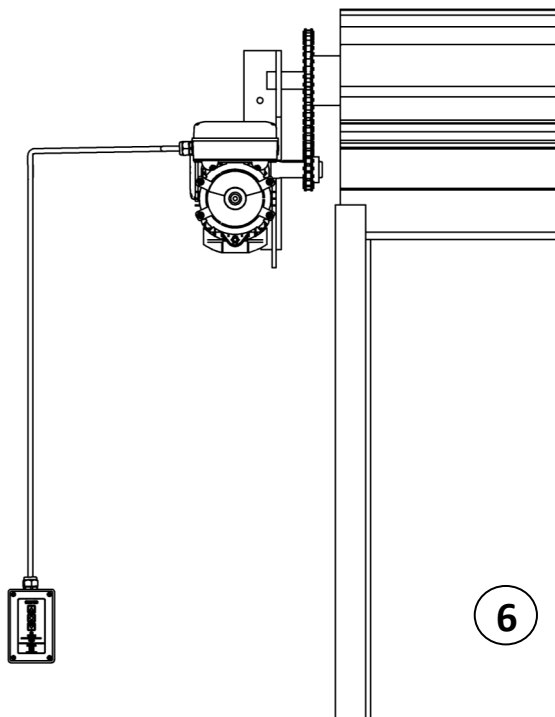

WARNING

When Securing the **eDrive +2.0** opener with the 4 x M12 x 40mm long fasteners (based on a 8mm mounting plate) and spring washers provided, it is critical to ensure that the applied torque is between 80-90Nm. When mounting through thicker sections, ensure a minimum of 30mm of screw thread is engaged with the female thread. Use of incorrect fasteners or torque may cause serious product damage, personal injury or death. When fixing through a slotted plate, ensure that the slots are no wider than 13mm as a spring washer may not be adequate in outside diameter to support the hexagon head.

Installing Hand Chain (Use 5mm long link chain only)

Ensure the mounting position allows the hand chain to hang free of obstructions.

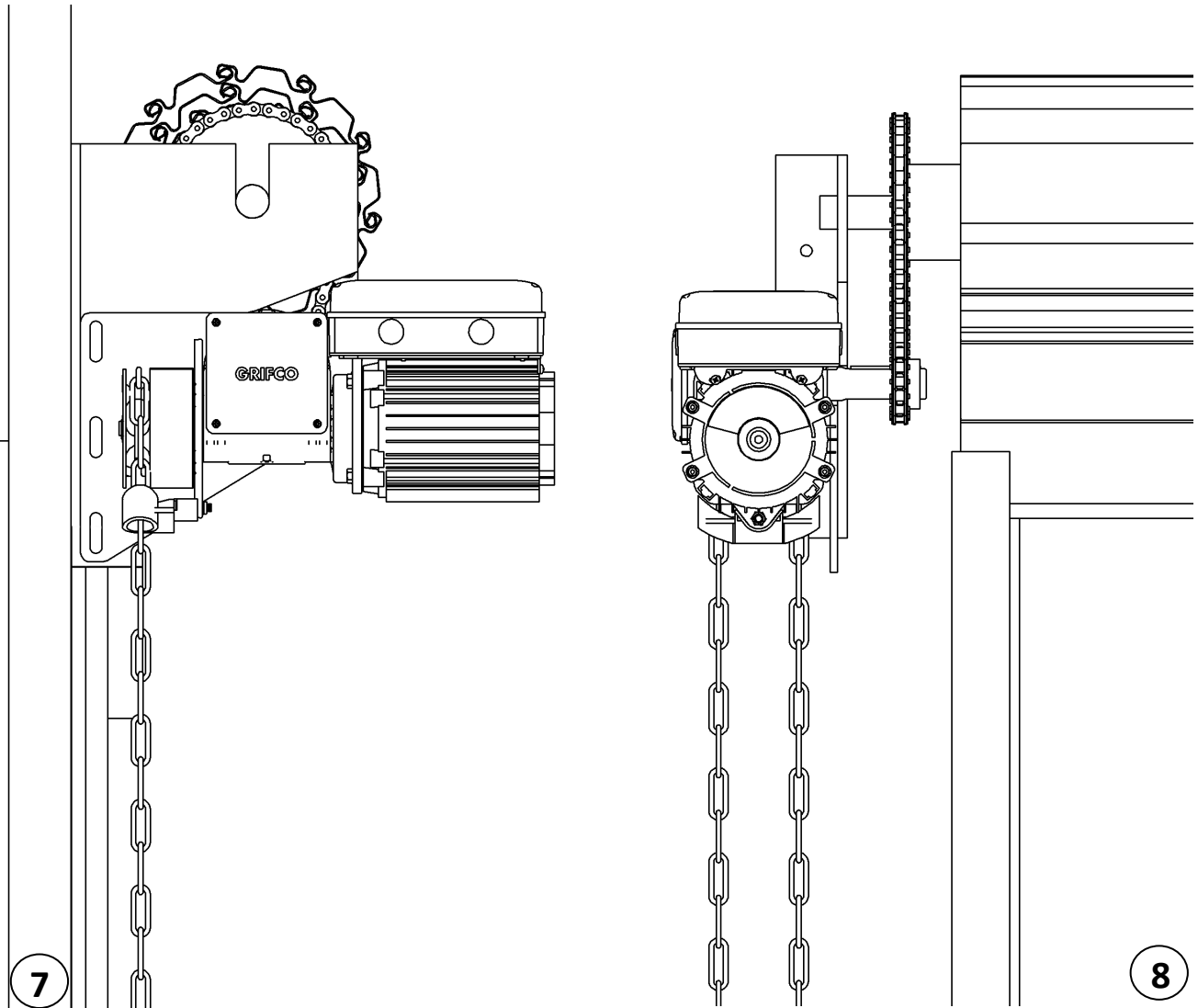

Ensure hand chain is not twisted when making the join!



CAUTION

Motor may become hot during operation. Appropriate clearance and/or shielding should be supplied by the installer to ensure any cabling, wiring and/or other items cannot come in contact with the motor. If temperature rise exceeds 50°C all cable wiring must be shrouded.

Fixed wiring insulation must be protected, for example, by insulating sleeving having an appropriate temperature rating.



ELECTRICAL CONNECTION

The eDrive + 2.0 opener **must**:

- be connected via an approved electrical isolation device
- be connected via a suitable circuit breaker that disconnects all live conductors
- be connected in accordance with the wiring rules of the country in which it is installed
- not have control enclosures left open for extended periods (excess dust will void warranty)

Connecting power (if fitted with a plug and lead proceed to next page)

A. 3 PHASE WITH NEUTRAL

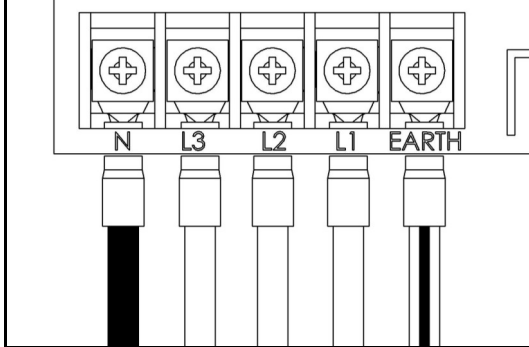

Supply connection for three phase builds with neutral

Models: ML5053, ML5103, MH5103 & ML5153

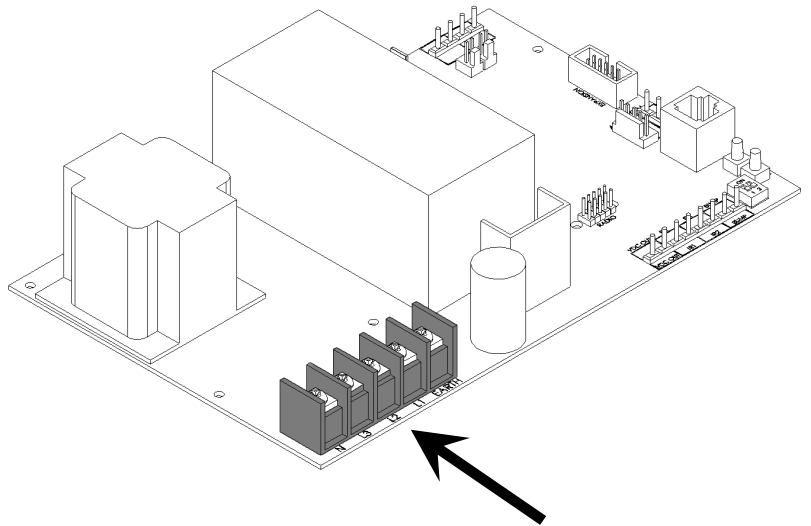

B. 3 PHASE NO NEUTRAL

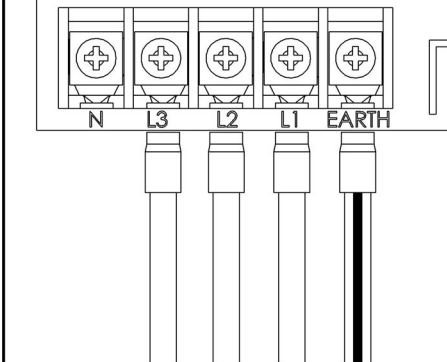

Supply connection for three phase builds **without** neutral

Models: ML5053N, ML5103N, MH5103N & ML5153N

C. SINGLE PHASE 3 WIRE

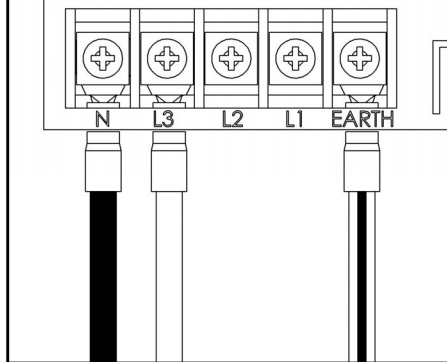

Supply connection for single phase builds 3 wire configuration

Model: ML5051

D. SINGLE PHASE 4 WIRE

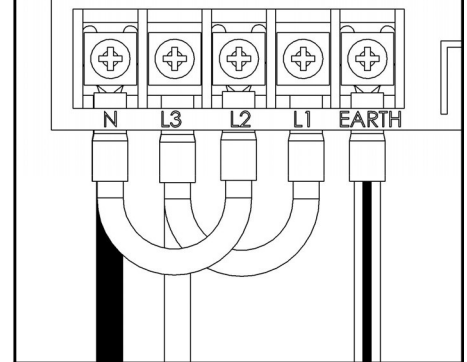

Supply connection for single phase builds 4 wire configuration

Models: ML5102 & MH5102

It is recommended that 1.5mm²(max.) wire size is used to avoid unnecessary crowding and difficulty when making connections. Avoid lengthy cable ends that may cause undue pressure on delicate components. It is recommended to crimp cable ends with fork or loop connectors to ensure a secure fitting in the terminal block.

Note:

- If the supply cord is damaged, it must be replaced by the manufacturer or its service agent or a similarly qualified person in order to avoid a hazard
- A disconnection device incorporated in the fixed wiring must be provided in accordance with the wiring rules of the country in which it is installed.

Controller

The eDrive +2.0 controller is the user interface for the opener. It consists of four buttons for control and setup, as well as three indicators to display the opener status.

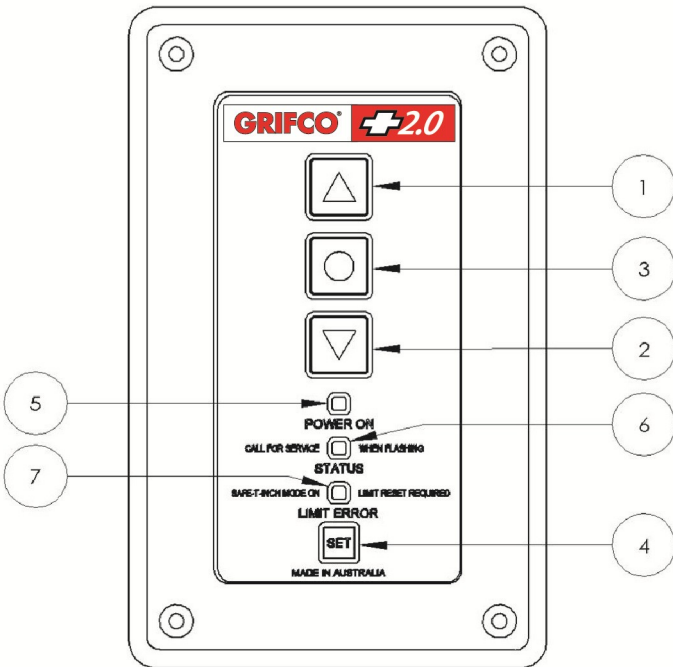

- 1) UP - Moves the door upwards
- 2) DOWN - Moves the door downwards
- 3) STOP - Stops the door
- 4) SET - Used primarily to set limits
- 5) POWER ON - Shows when the unit is mains powered
- 6) STATUS - Shows the status of the unit (refer page 22)
- 7) LIMIT ERROR – When lit indicates limits (or stopping positions) are not set, the door will only operate in SAFETY inch mode until limits are set (or reset). Refer page 12

WARNING

Install the controller in a position where the door is visible. Failure to do so may result in serious injury or death to persons trapped beneath the door. Minimum mounting height is 1.5 metres from floor level.

Installing the controller

The controller is connected to the MCB via a low voltage control cable provided within the controller enclosure. Using the conduit entries provided (also enclosed) run the cable through conduit. Be sure not to cut or damage the cable and therefore cause installation issues and void warranty.

CAUTION: Do not force the controller cable! Excess stretching and manipulation can cause cable failure. Plug ends must not be gripped with pliers.

To connect the controller to the eDrive +2.0 opener, identify the most appropriate entry of the MCB enclosure for your installation. Open the MCB enclosure and fit the conduit fitting, allowing enough cable to reach the controller (RJ45) socket. Place the opposing end of the controller cable through the conduit entry of the controller enclosure and pull through any excess cable. Plug the RJ45 end into the socket located within the controller assembly. Use the space provided within the controller enclosure to neatly coil any excess cable.

Note: If the supplied 6m controller cable is not long enough for your installation, use a Grifco® Controller Extension Kit, available from your local dealer or Chamberlain (P/N ESK01).

Automatic Chain Engagement Mechanism (ACEM)

The patented ACEM features allows the use of the hand chain in the event of a power failure. Simply pull on the hand chain in either direction to operate the door manually.

Warning! Ensure power is isolated when using this feature.

The ACEM label (see right) must be fixed in close proximity to the controller e.g. on the door track.



SETUP AND ADJUSTMENT

Once the installation of the opener and controller is complete it is time to test the operation. Make sure the door is away from the ground or the top door stops (mid open position). This will prevent damage to the door in the event that the door direction is reversed in relation to the controller (see below changing door direction).

Checking power

Ensure the unit is powered by checking that the *POWER ON* indicator on the controller is lit.

You should also notice that the *LIMIT ERROR* indicator (orange) is lit which signifies that there are no limits set.



CAUTION

On new installations, the orange limit light should be lit after initial power up. If not, DO NOT operate door unless in limit setting mode or serious damage or injury may occur.

Door direction

Check the direction of the door movement. If the direction of the door is incorrect, refer below to **Changing door direction**.



Changing door direction

To change the door direction first put the unit into 'limit setting mode'. To do this:

1. While holding STOP, press the SET button 3 times.
The *LIMIT ERROR* indicator will start flashing signifying 'limit setting mode'
2. Press and hold STOP for 10 seconds until the LIMIT ERROR indicator flashes quickly.

The direction of the door movement will now be reversed.

The LIMIT ERROR indicator will remain flashing as the unit is still in limit setting mode. You can now set limits (go to step 2 on next page)

Or to exit, press STOP.



WARNING

When removing or replacing jumpers on all circuit boards, mains power must be disconnected.



WARNING

It is important to make sure the door always runs smoothly. Doors which stick or jam must be repaired immediately. Employ a qualified technician to repair the door, never attempt to repair it yourself.

READ CAREFULLY BEFORE SETTING LIMITS!

(not applicable to roller shutters)

The eDrive + 2.0 features a **limit confirmation** routine that occurs after a power outage upon the first push of any operate button. By default, the routine will “jog” slightly downward in order to confirm door position before proceeding in the intended direction.

For doors of rigid construction (e.g. bi-fold, vertical lift, sectional or continuous steel roller doors etc) this routine should be changed so that the first “jog” movement is upward. To do so, proceed as follows:

- **While holding STOP, press the SET button 3 times and CONTINUE to hold STOP for 20 seconds (or until the orange light goes solid).**

Now proceed to **Setting limits**, ensuring the upper limit is set NO CLOSER than 50mm from the top stops (or fully open position) of the door.

Upon completion of the installation, turn power OFF, then back ON at the open and closed positions, and test proper operation accordingly.

RKML5051 models (1/2hp roller door openers) will confirm limits by jogging UPWARD first by default . To reverse the **limit confirmation** direction, proceed as above.

Setting limits

1. While holding STOP, press the SET button 3 times.
The LIMIT ERROR indicator will start flashing signifying ‘limit setting mode’
2. Use the DOWN button to drive the door to the desired CLOSED position.
The manual hand chain can be used to accurately position the door before pressing SET
3. Press the SET button to save this as the CLOSED position.
The LIMIT ERROR indicator will flash quickly then return flashing slowly
4. Use the UP button to drive the door to the desired OPENED position.
The manual hand chain can be used to accurately position the door before pressing set
5. Press SET again to save this as the OPENED position. The LIMIT ERROR indicator will flash quickly then will go out

The Closed and Open limits have now been set. If at anytime you need to exit ‘limit setting mode’, just press the STOP button.

Once set, operate the door between limits 2 – 3 times to check they are suitable. If not, return to STEP 1.

To verify limit confirmation routine, turn power OFF, then back ON at the open and closed positions, and test proper operation accordingly. If required, refer to top of page to reverse the limit confirmation direction.

They never mention that You should always open and close the door with the motor to see it runs smoothly before you set any limits and to have passed the halfway position for the motor to set properly or limits will not set.



WARNING

After the installation a final function test of the system and where present a full function test of the safety devices must be done.



WARNING

Do not place hands or tools near the opener when power is on or when testing controls or safety devices.

Always disconnect power before servicing or adjusting the opener.

Optional third limit (extended open position)

The third limit is a handy option for high doors that rarely need to be fully opened. The third limit is a door position above the open limit position which can be accessed when needed. Having this upper stopping position allows a mid height limit to be set as a first opening point, while a further press of the open button takes the door to a higher set position.

Setting the third limit

Once the Open and Closed limits have been set:

1. Position the door at the open limit position
2. While holding the UP button, press the SET button 3 times.
The LIMIT ERROR indicator will flash
3. Now open the door further until the door is in the desired extended open position
4. Press SET to save this as the extended open position.
The LIMIT ERROR indicator will quickly flash then go out

Accessing the third limit:

1. Open door to first upper limit
2. Press the UP button

OPERATION

To operate the door

Press the UP button on the controller to open the door, press and hold DOWN to close. For optional behavior refer to **Setting door behaviour** on the next page.

Manual operation

The hand chain provided allows manual operation of the door at all times when the motor is not in use. **Warning!** Use of the hand chain during powered operation of the door may result in damage to equipment or injury to the user. Ensure power is shut off before using manual chain.

Basic installation of the eDrive +2.0 Commercial Door Opener is now complete
Please refer to the following pages for further installation instructions of optional eDrive +2.0 features and / or accessories

DOOR BEHAVIOUR AND ENTRAPMENT PROTECTION INPUTS

Door behaviour modes

Latch up / Inch down mode (default):

The door will travel upwards with only a single press and release of the UP button. The door will stop at the set limit. This mode is **latch up**.

The door will only travel downwards when the DOWN button is held. The door will stop at the closed limit or when the button is released. This mode is **inch down**.

Inch up / Inch down mode:

The door will only travel whilst the UP or DOWN buttons are being held. The door will stop at the limits or when the button is released. To set this mode refer to **Setting door behavior** information below.

Latch up and down mode:

Note: This mode is only possible in conjunction with an Entrapment Protection Device such as an Infrared (IR) Beam or a Safety Bump Edge. Failure to do so may result in damage to property or injury to persons.

Setting door behaviour

To set the door behaviour modes, adjust the DIP switches in the corner of the MCB shown below.

Dip switch **1** is used to latch **DOWN** and switch **2** is used to latch **UP**.

At default the MCB is set to latch open and inch close, shown right. The door will open with a single press but only travel downwards while the down button is being held. For details on the 3 distinct modes refer above.

*** The door must only be set to latch DOWN if there is a suitable Entrapment Protection Device installed. Failure to do so can lead to serious injury or death.**

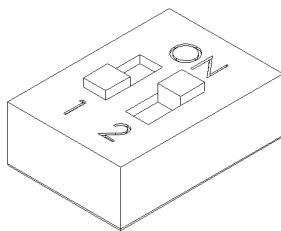
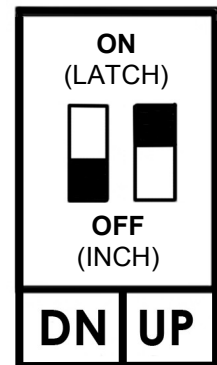

Latch up / inch down

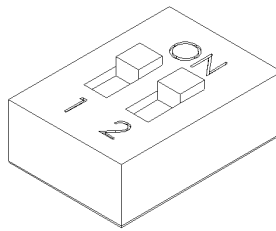

*Latch up / latch down



**Inch up / inch down

Note: **Both dups must be OFF (inch up/inch down) for Coles & BI-LO electrically operated roller door installations or when opener height is less than 2.5m from the ground without sufficient guarding of moving parts.

WARNING

Entrapment Protection

The Entrapment Protection System for your installation will be determined by the functional requirements of the door. To ensure the installation meets these requirements refer to AS/NZS 60335-2-103.

When using the Grifco® Protector System as part of the Entrapment Protection System, ensure it is installed to detect a 100mm high obstacle, ie; approx 80mm from the floor, and in accordance with installation directions supplied.

Consideration should be given to the detection of vehicles or other similar equipment. To provide adequate Entrapment Protection an additional Grifco® Protector System may be required to be installed in a higher suitable position, for example, approx 600mm from the ground.

Installing Entrapment Protection Devices (requires Terminal Blocks P/N TBT2A-5)

Devices such as Infrared (IR) Beams and Safety Bump Edges allow safe automatic or latch closing of the door and can be wired directly into the MCB via an appropriate cable entry. Grifco® Entrapment Protection Devices such as the Protector System and Bump Edge are wired into the quick connect inputs located next to the door behaviour dip switches on the MCB.

VDC OUT: Accessory power 24Vdc - unregulated
(max 150mA)

IR1: Monitored Grifco® Protector System, or
NC (normally closed) switching input

IR2: Monitored Grifco® Protector System, or
NC (normally closed) switching input

For more detailed information on installation refer to the Grifco® Protector System manual.

BUMP: Monitored 8K2 Resistor type Bump Edge input.

Erase Entrapment Protection Devices

Press RST button on the MCB for at least 10 seconds until green LED blinks rapidly.

Reactivate Entrapment Protection Devices

Follow the above install instructions.

Note: When installing Entrapment Protection Devices ensure that the door is at the open limit position.

Note: All Entrapment Protection Devices need to be activated once after installation to be learned correctly. Normally closed Entrapment Protection Devices and monitored Bump Edges require one simulated obstruction to be learned by the opener. Once learned, latch closing will be allowed when set.

Note: The eDrive +2.0 features “constant pressure to close”. This means that if an Entrapment Protection Device fails, the opener can still ‘inch down’ (unless an expansion board is used).

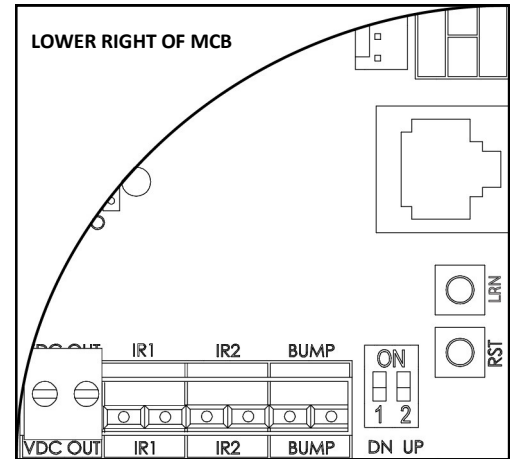

CAUTION: Grifco® Protector System must not be connected to VDC out.

Additional switchgear (eg. dedicated open/close and Auto Mode etc)

Caution! Any access control intended for these terminals must be user operated and in line of sight with the door.

The eDrive +2.0 can be easily interfaced by the reverse side of the controller push button panel (Refer to adjacent diagram). To do so you will need terminal blocks (P/N TB210) available from your local commercial door dealer or Chamberlain®.

Note: A controller must always be plugged in (see page 17 no. 2) for the opener to function. When utilising the AUTO or ESTP terminals the respective bridge must be removed, refer right.

Note: Additional 24VDC devices must not draw current from the MCB in excess of 150mA. Excessive load from connected devices will cause malfunction of the eDrive +2.0 opener. For additional loads, use a separately mounted power supply.

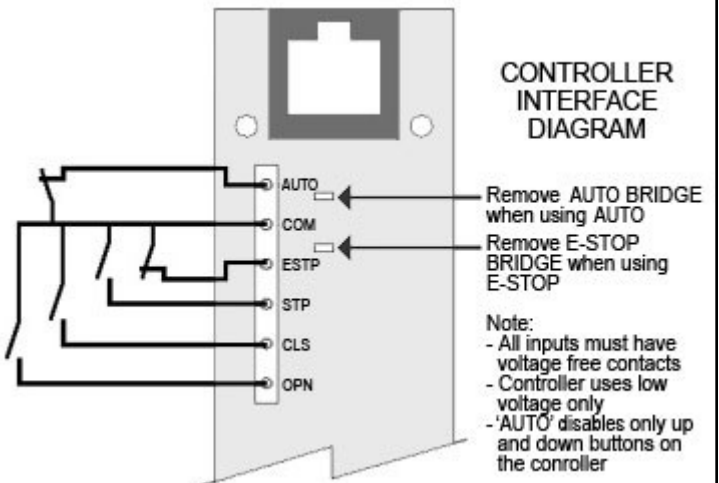

Note:
- All inputs must have voltage free contacts
- Controller uses low voltage only
- 'AUTO' disables only up and down buttons on the controller

Toggle Input (2 wire)

A 2 wire toggle input is provided on the MCB (see page 17) to allow single button (or access control) operation.

The input will operate as “open-stop-close-stop-etc.”

If Auto close is set, the toggle behaviour will become “open only”.

When the toggle input is bridged* and held (eg. a timer or latching switch) the door will remain open (ie Auto Close ignored). If the bridge is released, Auto Close will resume.

* If an EB is fitted, this feature will not be available on the MCB toggle input. Use EB com open input instead.

WARNING

Keep additional accessories away from children. Do not allow children to play with pushbuttons or remote controls. Without safety devices a door can cause serious injuries as it closes. Only trained people are allowed to use the opener.

Example of a Typical Car Park Application

The eDrive +2.0 has Car Park Access Control features included as standard.

For typical vehicular access applications, the product can be interfaced with access control devices and features an adjustable Auto Close function.

For vehicular access applications an Entrapment Protection System will be required — see “Installing Entrapment Protection Devices” on page 15.

Typical Car Park Configuration

- The opener must be installed in accordance with the instructions contained within this document.
- The Entrapment Protection Device/s must be installed before the product can be set for Auto Close.
- For Latch Up (open) and Latch Down (close) set the dip switches on the MCB in accordance with the “Setting Door Behaviour” instructions (see page 14)
- Set Auto Close in accordance with the instructions (see page 19).

Access Control Options

- Grifco® Security +2.0 Transmitter or other Grifco® Security +2.0 Wireless Accessories
- Swipe Card, Magnetic Key or similar access control device

The transmitter once programmed (see page 20) can control entry and exit for the user. Auto Close once set, will close the door after the programmed delay on both entry and exit.

Access control devices such as swipe card, magnetic key and other similar systems must be a two wire voltage free interface and be connected to the toggle input on the MCB via the quick connect pluggable terminal block (see diagram on page 17).

Transmitter Management

If transmitter management is required, you will need a Grifco® STAR1000EVO. This accessory will allow up to 1000 identified users to be individually added and deleted. Contact 1800 GRIFCO® for more information.

Exit Control

The door can be configured to open from either a:

- Grifco® Security+2.0 Transmitter or other Grifco® Security+2.0 Wireless Accessory device, or
- Where a loop detector or similar access controls are required to trigger opening to exit, connect to the toggle input on the MCB via a quick connect pluggable terminal block as described above (see diagram page 17).

Note – The Toggle Input will accept N/O inputs from multiple access control devices eg, both a separate entry and exit control.

Auto Close Feature

When Auto Close is enabled, the Toggle Input, and Receiver behaviour will become “Open Only” i.e. an activation via the Toggle Input or a Transmitter during opening, or Auto Close delay, will not close the door. Each activation will add Auto Close delay.

Advanced Logic Functionality

For applications where full logic functionality (eg relay status outputs, advanced door behaviour, building management system integration) is required please order the Grifco® EB1, Elite Expansion Board or complete Elite Expansion Kit. Contact 1800 GRIFCO® for more information.

MAIN CONTROL BOARD (MCB)

The MCB is the heart of the **eDrive +2.0**. The diagram below provides an overview of the major components and access points.

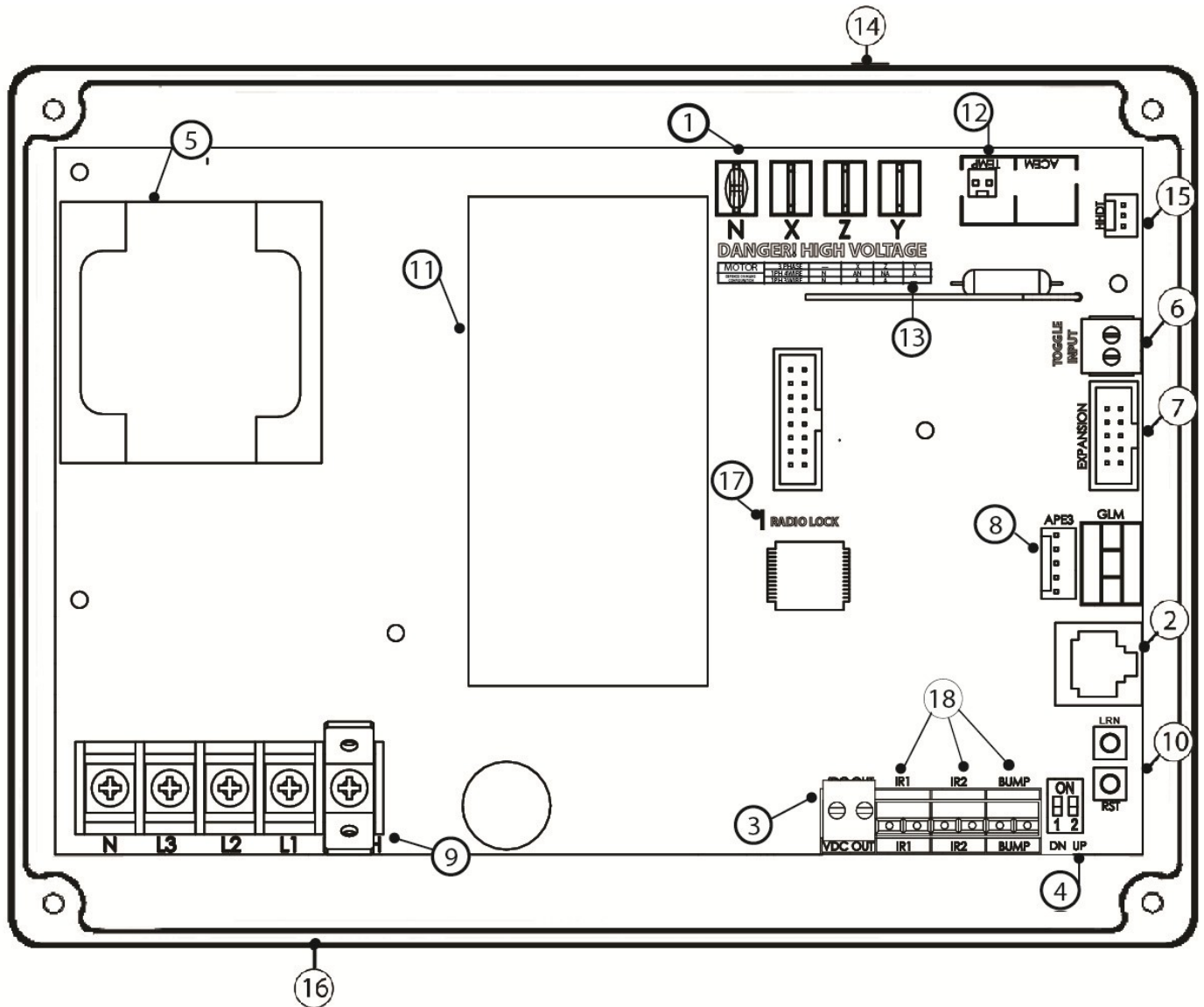

1	Motor terminals	10	'Learn' and 'Reset' buttons
2	Controller connection socket	11	Mechanically interlocked contactors
3	VDC out (24Vdc accessory power)	12	Motor temperature cut-out connector or relays
4	Door behaviour DIP Switches	13	Mains & Motor connection tables
5	Transformer	14	Controller cable entry (typical)
6	Toggle Input	15	HHDT input (diagnostic tool)
7	Expansion Board Input	16	Mains power cable entry (typical)
8	APE limit terminal	17	Radio Lock
9	Power supply terminals	18	Entrapment Protection Device inputs

GRIFCO® Security +2.0 Accessories



Forklift/Wall Remote

Experience the convenience of a versatile spare remote. Operate up to three doors or gates with one remote that can be fitted to a car, forklift or in the warehouse or factory.

Model: E943G (3 Button)



3 Button Key Ring Remote

Key ring remote transmitters are small and convenient with the ability to operate up to three doors or gates from the one unit. A must have for every set of keys for warehouse workers on site.

Model: E945G



Wireless Wall Control

The wireless wall control can be placed in a suitable location in your warehouse. There is no wiring and it can operate up to two doors and has a unique hold to close feature that is available without IR beams installed.

Model: E138G



Wireless Keypad

Secure Keyless entry via a four digit PIN code. The wireless keypad can be programmed with up to twelve user codes and has the option for temporary codes that last for as many hours or door openings as you select. Now you can have secure keyless entry and a unique hold to close feature that is available without IR beams installed.

Model: E840G



Infrared (IR) Reflective Beam

The new Grifco Protector System is a market leading pre-wired "plug-in" monitored reflective IR beam. The Protector System reduces installation time and features an adjustable IR beam assembly that increases alignment flexibility.

Model:
GPS15(Beams & install brackets only) and
GPS15RK (1 set of Beams & install brackets with 2 x E945G transmitters)



STAR1000EVO

The STAR1000EVO is a high capacity transmitter management system for commercial door openers, and dry contact triggered devices. The STAR1000EVO is compatible with Security +2.0 remote controls and wireless keypads. The receiver capacity is 1,000 wireless accessories and can be any combination of remote controls and wireless entry devices.

Model:
STAR1000EVO

- Call 1800 GRIFCO for assistance with any of the above accessories, or other enquiries -

AUTO CLOSE & WIRELESS ACCESSORY SET UP

Controller and MCB button reference

1. **UP** — Moves the door upwards
2. **DOWN** — Moves the door downwards
3. **STOP** — Stops the door
4. **SET** — Used primarily to set limits
5. **POWER ON** — Shows when the unit is mains powered
6. **STATUS** — Shows the status of the unit
7. **LIMIT ERROR** — When lit indicates limits are not set
8. **LRN** — Enables learning of new remotes
9. **RST** — Reset board. Hold this button for 10 seconds to erase and force re-learn of safety Entrapment Protection Devices.

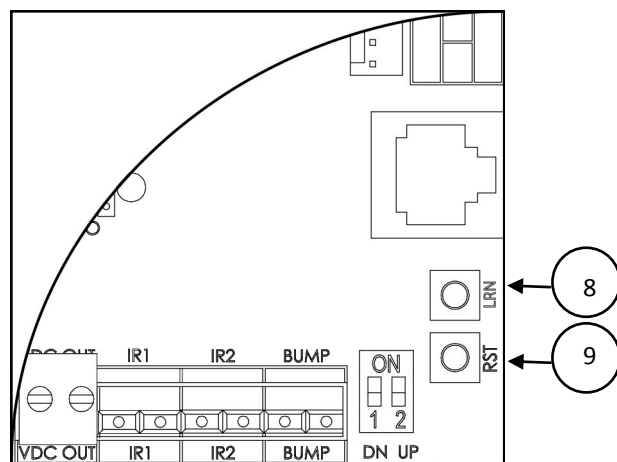
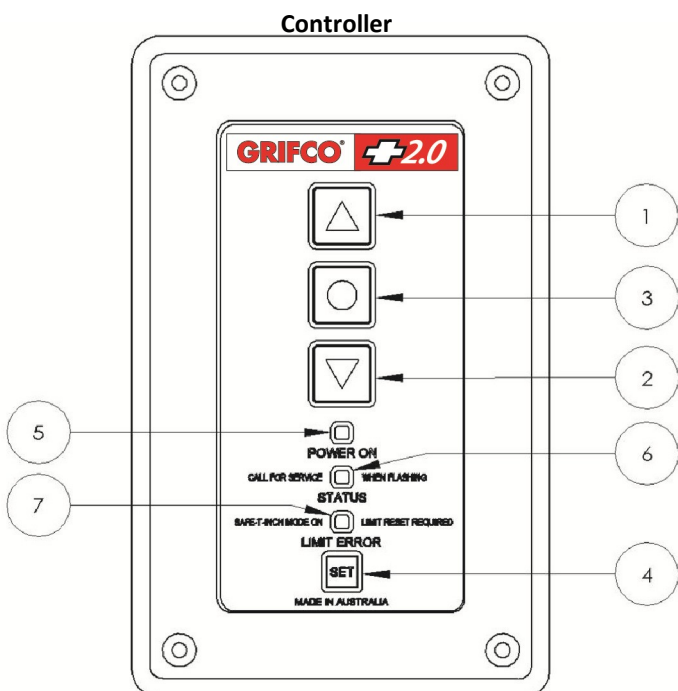
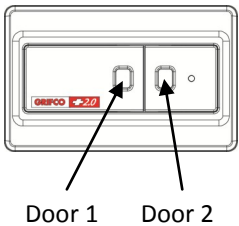
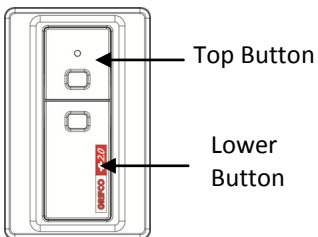



Figure 2. Lower Right corner of eDrive +2.0 MCB

Action	Button Sequence
<p>SET AUTO TIMER TO CLOSE (no expansion board fitted) FROM THE CONTROLLER</p>	<ul style="list-style-type: none"> • Press and hold the SET button, then whilst holding press the DOWN button 3 times (green status light ON solid) • Press the UP button to increase the auto-timer to close setting in 10-second increments • Press the DOWN button to decrease the auto-timer to close setting in 10-second increments • Note: the green light will flash according to the number of 10-second increments have been set, then goes back to solid ON. For example, a 5-minute auto-close will be set by increasing the increments until the green light flashes 30 times • Press SET to accept setting and exit learn mode • Note: To cancel the Auto-timer-to close function, enter the learn mode and press the DOWN button until the number of 10-second increments is ZERO. The green light will flash repeatedly to indicate the function has been reset, then return to solid ON • Press STOP to exit

AUTO CLOSE & WIRELESS ACCESSORY SET UP

NOTE: Radio Lock jumper (if fitted) must be removed from the MCB before wireless accessories can be learnt. Ref page 17.
For security reasons the Radio Lock should be refitted after the wireless learn sequence is completed.

Action	Button Sequence
LEARNING A NEW WIRELESS ACCESSORY FROM THE CONTROLLER	<ul style="list-style-type: none"> Press and hold the SET button, then whilst holding press STOP 5 times (green status light will light then continue flashing. Indicating learn mode) Press the desired WIRELESS ACCESSORY BUTTON to learn (orange limit light will flash fast after each wireless accessory is successfully learnt) Press STOP to exit learn mode
LEARNING A NEW WIRELESS ACCESSORY FROM THE MCB	<ul style="list-style-type: none"> Press the LRN button (green status light will light then continue flashing, indicating learn mode) Press the desired WIRELESS ACCESSORY BUTTON to learn (orange limit light will flash fast after each wireless accessory is successfully learnt) Press LRN button again to exit learn mode
ERASE ALL LEARNED WIRELESS ACCESSORIES FROM THE CONTROLLER	<ul style="list-style-type: none"> Press and hold the SET button, then whilst holding Press the STOP button 4 times, holding on the fourth press for 5 seconds (green light will flash 5 times, then fast flash to indicate completion) Check that previously learned wireless accessories no longer work
<p>LEARN THE E138G WIRELESS WALL CONTROL FROM THE CONTROLLER</p>  	<p>The E138G can be used as a two channel wireless wall control for use on one or two doors, or as a dedicated up/down wireless wall control. In either application for the door to latch down an Entrapment Protection Device must be installed. Without Entrapment Protection in two channel configuration the wall control will function as an open/stop device only and in dedicated up/down configuration the down button will operate as “hold to close” only.</p> <p>Two Channel Wireless Wall Control</p> <ul style="list-style-type: none"> Press and hold the SET button, then whilst holding press STOP 5 times (green status light will light then continue flashing. Indicating learn mode) Press the desired WIRELESS ACCESSORY BUTTON to learn door 1 (orange limit light will flash fast after each wireless accessory is successfully learnt) Repeat previous step to learn door 2 (if required) Press STOP to exit learn mode <p>Dedicated Up/Down Wireless Wall Control</p> <ul style="list-style-type: none"> Press and hold the SET button, then whilst holding press STOP 5 times (green status light will light then continue flashing. Indicating learn mode) Press the E138G TOP button (the orange LIMIT ERROR light will flash at each button press) Then press the E138G LOWER button Press the STOP button on the GRIFCO® controller (the green light will continue to flash) Press the E138G LOWER button again (the green light will go out indicating exit of learn mode)
<p>LEARN THE E840G WIRELESS KEYPAD FROM THE CONTROLLER</p> 	<ul style="list-style-type: none"> Press and hold the SET button on the GRIFCO® controller, then While holding the SET button, press the STOP button 5 times (the green status light will light then continue flashing, indicating learn mode) Enter a 4-digit PIN code into the keypad (step 3) Press the ENTER button (step 4) (orange LED flickers on controller) To enter additional PIN codes (up to 12) repeat steps 3 & 4 Press STOP to exit learn mode Install the RADIO LOCK button on the MCB to prevent any further wireless accessories being learnt, or erased without authority <p>NOTE: The Grifco® Security + 2.0 Wireless Keypad provides :</p> <ul style="list-style-type: none"> Wireless security access Wireless hold to close

MAINTENANCE



Power MUST be turned off before servicing or adjusting the opener. Disconnect the supply when cleaning!

The eDrive +2.0 is equipped with smart logic to indicate when your commercial door will require servicing. When the STATUS indicator flashes constantly please contact your commercial door dealer to arrange a routine door service.

Frequently examine the installation for imbalance and signs of wear or damage to cables, springs and mounting. Do not use if repair or adjustment is necessary. Power must be turned off before servicing, cleaning or adjusting the opener.

* Service Status Indicator is factory set to OFF. To enable this feature a Chamberlain Hand Held Diagnostic tool is required. Service interval must be determined by the installer based on the projected door usage.

Certain mechanical aspects of the installation must be checked, see below:

Monthly

- Examine the installation for imbalance and signs of wear or damage to cables, springs and mounting. Do not use if repair or adjustment is necessary *
- Check chain alignment, tension and condition. Adjust / replace if required *
- Check PE / IR beam/s and bump edge functionality where applicable

Quarterly

- Check tightness of fixing bolts and (sprocket) grub screws. Adjust if required * refer page 7
- Check correct electrical operation
- Check manual operation via hand chain
- Lubricate the drive chain *
- Check door balance. The drive chain should display a transition of tension from one side of the linkage to the other in the lower half of the roller door travel. This transition is the 'balance' point. Adjust if required *
- Conduct door maintenance in accordance with door manufactures guidelines. This will include door balance *

* SERVICE MUST BE CARRIED OUT BY A QUALIFIED TECHNICIAN

To view total cycles (limits must be set)

- Drive to door to closed limit.
- Press and hold CLOSE for 10 seconds.
- After 10 seconds and while still holding CLOSE, press and release the SET button.
- Status LED will light up indicating number of cycles performed.

To read number of cycles, follow the 'Reading Status Flashes' routine described below.

Reading Status Flashes

- STATUS indicator will start flashing to signify the value of the least significant digit of the overall number. A solidly lit indicator stands for zero.
- Press set to view the next digit.
- Continue previous step until the STATUS indicator flashes quickly for 1 second then goes out. This signifies that the entire number has been displayed.

To reset error

(This process indicates there has been a severe problem. Persistent resetting will void warranty and may damage the door and/or opener). This procedure will only work when the status light is flashing **4, 5, 9, 10, 14** or **15** times.

- Hold the STOP button for 10 seconds
- While still holding the STOP button, press and release the SET button

The STATUS indicator should flash quickly for 1 second. Any errors that were flashing should have stopped.

HHDT (Handheld Diagnostic Tool)

The HHDT allows you to set service interval warnings, and view numerous statistics and information including, total cycles, cycles since service, viewing software version, number of transmitters programmed and load reversals.

The input can be found in the corner of the MCB adjacent to the ACEM terminal, see page 17 No.15.

The diagnostic tool is also used to enable the service cycle alert (refer HHDT manual for procedure). The eDrive +2.0 service cycle alert is factory set in disabled mode.



TROUBLESHOOTING

Status Indicator (Green) Flash / Problem Table

No. flashes/ Problem	Meaning	Possible causes	Possible Solutions
Solid ON	Motor running		
2	Infrared beam and/or Bump edge obstruction N/C beam removed	IR beam obstructed Bumper edge pressed The opener has detected removal of an Entrapment Protection	<ul style="list-style-type: none"> • Clear obstruction • Remove pressure from bump edge • Set DIP 1 to OFF and press 'reset' (RST) button on MCB for 10 seconds. Re-learn any remaining Entrapment Protection Devices
3	Entrapment Protection Device removed	The opener has detected removal of an Entrapment Protection Device	<ul style="list-style-type: none"> • Set DIP 1 to OFF and press 'reset' (RST) button on MCB for 10 seconds. Re-learn any remaining Entrapment Protection Devices (see page 15)
4	MCB error	Internal Error	<ul style="list-style-type: none"> • Power off, and on. If un-resettable replace MCB
5	EB internal error	EB disconnected or ignored from MCB	<ul style="list-style-type: none"> • Return EB to the installation or resolve EB issue, refer Elite Manual
9	APE error 1 APE error 2	APE position jump Severe close range frequency APE cable disconnected APE cable fault	<ul style="list-style-type: none"> • Replace APE assembly • Press 'reset' (RST) button on MCB for 3 seconds • Reconnect APE cable • Replace APE cable
10	Under speed error	Extreme load on door	<ul style="list-style-type: none"> • Check for objects causing interference to door operation • Check door installation • Check for damage to motor • Upgrade to a larger opener
12	Thermal overload	Motor overheating	<ul style="list-style-type: none"> • Use opener less frequently • Upgrade to a high cycle opener
14	Direction error	Motor connections altered	<ul style="list-style-type: none"> • Change door direction and reset limits
15	Clutch slip (if fitted) No speed detected Contactor failure	Clutch adjustment set too low Motor stalled Extreme vibration or impact during transit	<ul style="list-style-type: none"> • Check clutch adjustment • Check door for mechanical failure or motor fault • Replace MCB
Constant flash	Due for service	Door is due for routine service	<ul style="list-style-type: none"> • Contact your local door dealer to arrange service
No Lights Displayed	Power failure – No lights on MCB or Controller *With lights on at MCB	Power supply not correctly connected *Bad connection to Controller	<ul style="list-style-type: none"> • Check transformer • Check power supply wiring • *Refer below if lights are on at MCB and not on Controller
Push button not responding	Opener does not drive up and / or down	Bad connection to Controller Damaged Controller cable Controller buttons forced and dislodged from rear of lid	<ul style="list-style-type: none"> • *Check RJ45 plugs are clipped in securely at Controller and MCB • *Check connections • *Replace Controller cable • *Replace Controller
Open or Close button not responding but green light comes on	Coil failure or incorrect motor wiring if green light on whilst holding up or down button and opener does not move in one direction	Extreme vibration or impact during transit Incorrect motor terminal connection	<ul style="list-style-type: none"> • Replace MCB • Correctly wire the motor

IMPORTANT NOTE:

If a problem is found with an installation, be sure to read the troubleshooting guide thoroughly. If the problem persists call Chamberlain for technical assistance on **1800 GRIFCO®** or email **customerservice@chamberlainnz.com** in Australia or in New Zealand call **0800 653 667**.



Power MUST be turned off before servicing or adjusting the opener. Disconnect the supply when cleaning!

1. No indicator lights on controller:

- Are there any indicator lights ON the MCB (Main Control Board)?

YES... Check connection between MCB and wall control

Check for damage to control cable

NO... Check power supply

2. Power light illuminated on controller but door will not go up:

- Does the green status light come ON when button is being pressed?

YES... Check for loose motor terminal connection. If green light begins to flash refer '**Troubleshooting**' (pg.22)

NO... Check for control circuit isolating switch or connection between MCB and controller

Check for damage to control cable

3. Power light illuminated on controller but door will not go down:

- Is the green status light flashing **2** or **3** times?

YES... 2 times - check for obstructions or IR beam misalignment

3 times - check for persistent IR beam obstruction, misalignment or bump edge wiring problem

Check for correct wiring connection and DIP switch settings on MCB

NO... *continue onto next question*

- Does the green status light come ON when down button is being pressed?

YES... Check for loose motor terminal connection. If green light begins to flash refer '**Troubleshooting**' (pg.22)

NO... Check for control circuit isolating switch or connection between MCB and controller

Check for damage to control cable

4. Can't set limits:

- Does the orange light start flashing after third press of the 'set' button?

YES... But green status light starts to flash 'x' times while attempting to set upper limit. Refer

Troubleshooting' (pg.22)

NO... Ensure all external devices and external push buttons are disconnected from wall control

Check for damage to control cable

5. Opener activates from controller but not remotes:

- Are limits set?

YES... Change remote battery. If using Expansion board check key switch position is in auto and check MCB and

Expansion board DIP switches are set correctly. Check that remote is learned and receiver card is picking up signal

NO... Set limits.

6. Opener will only travel around 200mm either way:

- Are limits set? i.e. orange limit light ON = limits not set

YES... Check damaged to control cable

NO... Set limits. Refer page 12. If unable to set limits refer to above no. 4

7. Works from controller but automatic functions do not: (only applicable when using an Expansion Board)

- Is there a solid orange (COMS) light on the Expansion Board?

YES... MCB (Main Control Board) must be reset. Call Chamberlain (1800 GRIFCO) for resetting procedure

NO... Make sure key is in correct position

8. Power light intermittently goes OFF and ON:

- Is the power light going off on the MCB also?

YES... Check supply wiring

NO... Check connection between MCB and controller

Check for damage to control cable

CHAMBERLAIN LIMITED WARRANTY

Grifco Products

Chamberlain Australia Pty Limited / Chamberlain New Zealand Limited (**Chamberlain**) is committed to manufacturing and supplying high quality goods. As part of this commitment, we seek to provide reliable service and support for our goods and are pleased to provide you, the original purchaser, with this Chamberlain Limited Warranty.

We also provide the following statement as required by the Australian Consumer Law: In Australia, in addition to your rights under this Chamberlain Limited Warranty, our goods come with guarantees that cannot be excluded under the Australian Consumer Law. You are entitled to a replacement or refund for a major failure and for compensation for any other reasonably foreseeable loss or damage. You are also entitled to have the goods repaired or replaced if the goods fail to be of acceptable quality and the failure does not amount to a major failure.

Chamberlain's warranty

Chamberlain warrants to the original purchaser of the Grifco product (**Unit**) that:

- 1 The Unit (excluding the electric motor) is free from defects in materials and workmanship for a period of 24 months from the date of purchase.
- 2 The electric motor is free from defects in materials and workmanship for a period of 12 months from the date of purchase.

During the applicable Chamberlain Warranty period, if you are concerned that the Unit or electric motor may be defective, call our service centre on the toll free number below before removing the Unit and a Chamberlain technician will diagnose the problem. Once the problem has been diagnosed, subject to your rights under the Australian Consumer Law with respect to major failures, Chamberlain will provide you with:

- 1 parts for "do-it-yourself" repairs; or
- 2 shipping instructions for a factory repair or replacement.

If a factory repair or replacement is required, provided the defective part or Unit is returned to Chamberlain well-packaged and in accordance with Chamberlain's shipping instructions, Chamberlain will, subject to your rights under the Australian Consumer Law with respect to major failures:

- 1 in relation to the Unit (excluding the electric motor), repair or, at its option where permissible, replace any defective part or Unit (excluding the electric motor) and return it to you at no cost; and
- 2 in relation to the electric motor, replace the electric motor and return it to you at no cost.

Where the Unit has been installed by an authorised installer, you must call them for prompt on-site service. Chamberlain will furnish replacement parts free of charge through the authorised installer. A service fee for on-site service may apply.

Repairs and replacement parts provided under this Chamberlain Limited Warranty are provided free of charge and are warranted for the remaining portion of the original warranty period.

This Chamberlain Limited Warranty provides benefits which are in addition to your other rights and remedies as a consumer.

Exclusions

If our service centre determines that a warranty claim has been made in respect of a failure or defect arising under or out of any exclusion detailed below such that the claim is not covered under this Chamberlain Limited Warranty, we may, subject to your other rights and remedies as a consumer, charge you a fee to repair, replace and/or return the Unit to you.

This Chamberlain Limited Warranty does not cover any failure of, or defect in, the Unit due to:

- 1 non-compliance with the instructions regarding installation, operation, maintenance and testing of the Unit or of any product with which the Unit is used;
- 2 any attempt by a person other than an authorised installer to change settings, repair, dismantle, reinstall or move the Unit to another location once it has been installed;
- 3 tampering, neglect, abuse, wear and tear, accident, electrical storm, excessive use or conditions other than normal commercial use;
- 4 use of the Unit in conjunction with controls which have not been supplied, or pre-approved, by Chamberlain;
- 5 problems with, or relating to, the commercial door or commercial door hardware, including but not limited to the door springs, door rollers, door alignment, hinges, guides, slats and drums; or
- 6 problems caused by electrical faults.

If this Chamberlain Limited Warranty does not apply, you may have rights available to you under the Australian Consumer Law.

Liability – Australia only

Except as set out in the Australian Consumer Law (being Schedule 2 of the *Competition and Consumer Act 2010*) (as amended, consolidated or replaced):

- 1 all other guarantees, warranties and representations in relation to the Unit or its supply are excluded to the extent that Chamberlain can lawfully exclude them; and
- 2 under no circumstances will Chamberlain be liable for consequential, incidental or special damages arising in connection with the use, or inability to use, the Unit, other than those which were reasonably foreseeable as liable to result from the failure.

Liability – New Zealand only

Except as set out in the *Fair Trading Act 1986* and the *Consumer Guarantees Act 1993* (as amended, consolidated or replaced):

- 1 all other guarantees, warranties and representations in relation to the Unit or its supply are excluded to the extent that Chamberlain can lawfully exclude them; and
- 2 under no circumstances will Chamberlain be liable for consequential, incidental or special damages arising in connection with the use, or inability to use, the Unit, other than those which were reasonably foreseeable as liable to result from the failure.

Note

We request that you retain your sales docket or invoice as proof-of-purchase and attach it to this manual to enable you to establish the date of purchase in the unlikely event of a warranty service being required. Chamberlain reserves the right to change the design and specifications of the Unit without prior notification. Some features or accessories of the Unit may not be available in certain markets or areas. Please check with your distributor.

Chamberlain service centre contact details

Australia

Phone toll free 1800 474 326
Fax toll free 1800 888 121
Unit 1, 75 Epping Road
North Ryde, NSW 2113

New Zealand

Auckland phone 09 477 2823
Phone toll free 0800 653 667
Fax toll free 0800 653 663

Email

customerservice@chamberlainanz.com

Websites

www.grifco.com.au or www.grifco.co.nz