

# MB206 Rev03 LOGIC CONTROL

MADE IN AUSTRALIA

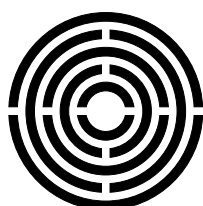

# LIFTMASTER

**Please read these instructions  
carefully before adjusting the  
Liftmaster Magic Button MB206  
control boards default parameter  
settings**

# 1.0 MB206 MAIN FEATURES

- ☑ LCD display with back-light
- ☑ Micro controller design
- ☑ Rotary switch mode selection
- ☑ End of travel slow down with adjustment
- ☑ Motor force control with adjustment
- ☑ Suitable for single or dual motors with or without limits
- ☑ Back pressure release for electric locks
- ☑ Electric lock or magnet output
- ☑ Open and close leaf delay control
- ☑ Adjustable open and close movement delay
- ☑ Inputs for push button and pedestrian access
- ☑ PE safety input for protection on closing
- ☑ PE safety input for protection on opening
- ☑ Output for flashing lights
- ☑ STOP input for safety on opening and closing
- ☑ Output for inverter control
- ☑ Output for indication of board status
- ☑ Backup closing timer
- ☑ 6 pin receiver compatible
- ☑ On board antenna input
- ☑ 12v DC regulated 100mA power supply
- ☑ 24v DC 300mA power supply protected by 1A fuse
- ☑ Motors output protected by 5A fuse
- ☑ Optocoupler protection on all inputs
- ☑ LED indicators on all inputs for visual indication on input status
- ☑ Resettable and non-resettable counters

**Note:** The availability of some of this control board's features are dependent upon individual applications and motor drive configuration. Qualify feature suitability before use

## **2.0 IMPORTANT SAFETY INSTRUCTIONS**

Please read these important safety rules. Failure to comply with the following safety rules may result in serious personal injury and/or property damage.

**2.1** When the MB206 logic control board is used to control gate, door, and barrier gate operating equipment the following factors **MUST** be taken into account:

**A)** Appropriate safety devices relevant to the particular application must be incorporated into the installation of all moving structures.

**B)** Safety devices need to be regularly checked for the correct operation.

**C)** The gate or door must be able to be freely moved by hand before motorisation.

**D)** Warning signs must be visibly installed on either side of the structure(s).

**E)** All programming must be undertaken by qualified technicians.

**F)** Any device used to initiate the logic controller must be kept away from children.

**G)** Wind loading on the operated structure(s) will unavoidably alter operation functions.

**2.2** Do not activate the MB206 logic control board unless the moving structure is in full and clear view and free of objects such as vehicles and people.

**2.3** The MB206 logic controller must be connected to properly approved earthed 240V power supply.

**2.4** The main power supply must be disconnected before making any repairs.

**2.5** Any additional device(s) utilising the MB206 on board DC power supply must not exceed, under load, the total transformer Amp rating.

**2.6** Water, dust, and insect presence on the MB206 logic control board must be prevented.

**2.7** Do not leave packing materials (plastic, polystyrene, etc.) within reach of children as such materials are potential sources of danger.

**2.8** Liftmaster declines all liability caused by improper use or use other than that for which the automated system was intended.

**2.9** Do not install the equipment in an explosive atmosphere: the presence of inflammable gas or fumes is a serious danger to safety.

**2.10** Liftmaster is not responsible for the failure to observe good technique in the design and construction of the structure(s) to be motorised and or any deformation that may occur during use.

**2.11** If parameter P14 (Back Up Timer) or P17 (Ped Auto Close) is used the door/gate once the run time is complete or the limits reached, will **automatically close** when the set value of back time has expired. This closing will occur without **warning, an appropriate safety device must be installed.**

**2.12** The effectiveness and compatibility of parameter P11 (slow speed) is dependent of the type of motor to be controlled, qualify the suitability of P11 before use.

## **3.0 INSTALLATION GUIDELINES**

All electrical works must be carried out by a qualified electrical contractor in accordance with local authority regulations. Following is a list of installation guidelines:

**3.1** Input power supply to the board is 240V 3 wire (Active, Neutral, and Earth). The input supply must have some means of power isolation.

**3.2** All wiring conduit and cable gland entries to control box should be via the base only.

**3.3** The recommended motor wire size is 1.5mm<sup>2</sup> stranded. For the control circuits the wire size is 0.5mm<sup>2</sup> stranded. High and low voltage cabling should not be run in the same conduit.

**3.4** If control board is part of an installation where Variable Speed Drive (inverter) is used and the motor is mounted away from the control board, the cable between the inverter and the motor must be a SCREEN type and the screen wire should be earthed at both ends.

The Photo Electric wires must be overall screen data wire 0.5mm<sup>2</sup> and the screen needs to be connected at board side to earth and 0v.

**3.5** All control and limit switch inputs must be DRY switch contacts only. Ensure that all devices being used for gate/door activation have dry contact outputs before connecting to control board. If the device has a voltage output, a relay will be required.

## **4.0 WIRING MOTORS TO THE CONTROL BOARD**

- 1.** Connect motor(s) to control board. If one motor is used connect it to M1 terminals and remove M2 limit wires. If electric lock is used the lock must be mounted on motor 1 gate. Once motor(s) are connected to control board, manually move gate/door to the mid position and engage the motor.
- 2.** Turn power on to control board and activate motor(s) (using push button or programmed remote etc). Motor(s) should move towards open position. If the gate/door moves towards closed position, switch power OFF and reverse open/close motor wires (and open/close limit wires where used). Turn power ON and re-test for correct motor operating direction.
- 3.** Once correct motor direction is established, the board parameters can be modified to suit the installation, and the mode selected.

## **5.0 STATUS INDICATORS L1 - L10**

- L1** - Motor one open limit input status: normally ON, OFF when open limit activated. GREEN LED
- L2** - Motor one close limit input status: normally ON, OFF when open limit activated. RED LED
- L3** - Motor two open limit input status: normally ON, OFF when open limit activated. GREEN LED
- L4** - Motor two close limit input status: normally ON, OFF when open limit activated. RED LED
- L5** - Closing safety input indicator: indicates if safety input obstructed, MUST be OFF for board operation. RED LED
- L6** - Opening safety input indicator: indicates if safety input obstructed, MUST be OFF for board operation. RED LED
- L7** - ON indicator for PB1 input. GREEN LED
- L8** - ON indicator for PB2 input. GREEN LED
- L9** - ON indicator for STOP button. RED LED
- L10** - Board status indicator: indicator OFF when the board is idle and the motor is in the CLOSED position. Once PB1 or PB2 input made, then indicator remains ON until the cycle CLOSE-OPEN-CLOSE is complete either by limit(s) or when the close travel time setting is expired. GREEN LED

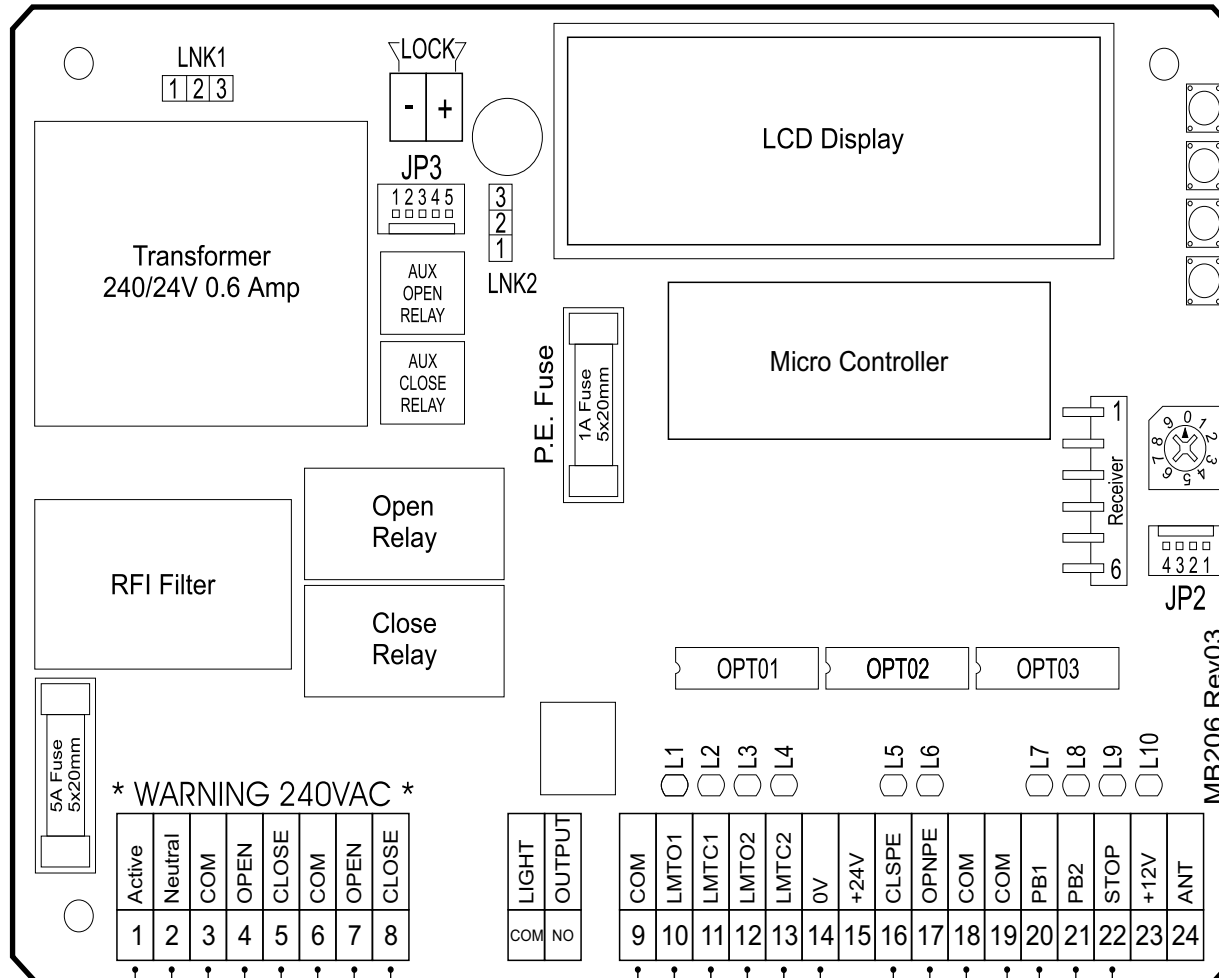

- ← NEXT: Move to the next parameter
- ← UP: Increase the parameter value
- ← DOWN: Decrease the parameter value
- ← SET: Save the parameter value

- ← Mode Selection: 0. Programming
  1. Pulse open / pulse close
  2. Pulse open / auto close
  3. Pulse open / P.E. close
  4. Counting mode
  5. Open / Close / Stop

**Note on Fuses:** before changing th fuse(s) identify the cause of the fault, rectify and then check board functionality including slow down speeds.

**Note:** +12v power supply is 100mA  
+24v power supply is 300mA

\* WARNING 240VAC \*

Active	Neutral	COM	OPEN	CLOSE	COM	OPEN	CLOSE
1	2	3	4	5	6	7	8

LIGHT	OUTPUT
COM	NO

COM	LMTO1	LMTC1	LMTO2	LMTC2	0V	+24V	CLSPPE	OPNPE	COM	COM	PB1	PB2	STOP	+12V	ANT
9	10	11	12	13	14	15	16	17	18	19	20	21	22	23	24

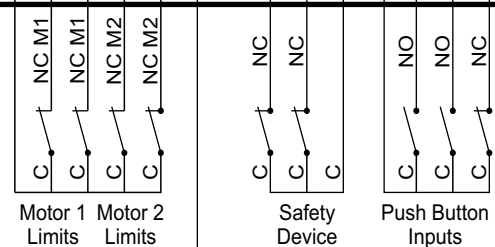
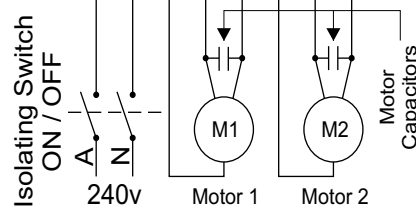

Connect to ground when board is used with inverter

**MB206 Rev03 CONTROL BOARD**  
**FOR 3-WIRE 240V 5A MOTORS**

LIFTMASTER ELECTRONICS PTY LTD  
 Phone: (02) 9699 9654 Fax: (02) 9699 8443

MB206 - 0210 - Rev03

## 6.0 MB206 MODE SELECTIONS

For mode selection a '0' to '9' rotary switch is used.

### **MODE 1 DOMESTIC POSITION 1**

Gate/door opens on impulse, and closes off a single impulse. While opening a pulse will stop the gate/door from fully opening. The next pulse will close the gate/door.

While closing, if photo electric is interrupted or a pulse is applied, the gate/door will re-open and a second pulse is required for the gate/door to close.

### **MODE 2 AUTO CLOSE POSITION 2**

Photo Electrics are mandatory for this mode. Gate/door opens on impulse and closes automatically after preset time (P3).

While closing, if the photo electric is interrupted or a pulse is applied, the gate/door will re-open fully and re-close after the preset time (P3) expires and the photo electric is cleared.

### **MODE 3 PHOTO ELECTRIC CLOSE POSITION 3**

Gate/door opens on impulse and closes only after the photo electric is broken and cleared.

While closing, if the photo electric is interrupted or a pulse applied, the gate/door will re-open fully and re-close after preset time(P3) expires and the photo electric is cleared.

### **MODE 4 COUNTING MODES POSITION 4**

The number of pulses to open are counted, and gate/door will only close when the photo electric is broken and cleared the same number of times.

While closing if a pulse is applied gate/door will re-open and then require the count photo electric to be broken and cleared to close. If photo electric is interrupted the gate/door will re-open and re-close after preset time (P3).

### **MODE 5 MANUAL MODE POSITION 5**

Gate/door opens on impulse from PB1 and closes off impulse from PB2.

While closing if photo electric is interrupted the gate/door will re-open and wait for an impulse from PB2.

## 7.0 HOW TO MODIFY PARAMETERS

Parameters can be adjusted in both the open and closed position.

1. Turn rotary switch to position 0, LCD backlight will turn on during programming.
2. Display will show the first parameter P1.
3. To change the parameter value press the UP or DOWN buttons.
4. To modify the next parameter, press the NEXT button.
5. To save values, press the SET button, turn rotary switch to the desired mode, position 1, 2, 3, 4 or 5

The following is a list of parameter values that can be modified.

'P' = parameter, 'M' = motor, 'Def' = default, 'Now' = saved parameter

DISPLAY ON LCD	COMMENT	RANGE	MY SETTINGS
P1 = M1 Travel Time Def: 5 Now: 5.0s	Set motor 1 travel time.	0 – 60 secs	
P2 = M2 Travel Time Def: 5 Now: 5.0s	Set motor 2 travel time.	0 – 60 secs	
P3 = Auto Cls Time Def: 1 Now: 1.0s	Set hold open time delay before closing.	0 – 60 secs	
P4 = M1 Close Delay Def: 1 Now: 1.0s	Delay motor 1 before closing.	0 – 10 secs	

P5 = Opn Movement Delay Def: 0 Now: 0.0s	Delay both motors before opening.	0 – 10 secs	
P6 = M2 Open Delay Def: 1.0 Now: 1.0s	Delay motor 2 before opening	0 – 10 secs	
P7 = M1 Force Adj Def: 50% Now: 50%	Adjust motor 1 force.	50 - 100 %	
P8 = M2 Force Adj Def: 50% Now: 50%	Adjust motor 2 force.	50 - 100 %	
P9 = M1 Slow Down Def: 0 Now: 0.0s	Motor 1 slow down prior to stopping.	0 - 5 secs	
P10 = M2 Slow Down Def: 0 Now: 0.0s	Motor 2 slow down prior to stopping.	0 - 5 secs	
P11 = Slow Speed No. Def: 1 Now: 1	Select slow speed option 2 if motor is excessively jerky during slowdown	1 - 2	
P12 = M1 Soft Start Def: 0 Now: 0.0s	Motor 1 soft start.	0 - 5 secs	
P13 = M2 Soft Start Def: 0 Now: 0.0s	Motor 2 soft start.	0 - 5 secs	
P14 = Back Up Close Time Def: 0 Now: 0.0s	Not suitable for modes 1, 2, 4, or 5. Close door/gate if back out occurs & close PE/Loop not triggered. <b>WARNING: must use safety devices.</b>	0 - 60 secs	
P15 = Extra Open Time Def: 5 Now: 5.0s	Add additional open time to P1 and P2 to compensate for wind or mechanical loading.	0 - 30 secs	
P16 = Extra Close Time Def: 5 Now: 5.0s	Add additional close time to P1 and P2 to compensate for wind or mechanical loading.	0 – 30 secs	
P17 = PedAutoClose Def: 0 Now: 0.0s	Set pedestrian mode to automatic close, set to 0.0s for no auto close. <b>WARNING: must use safety devices.</b>	0 – 60 secs	
P18 = Cls PE Reverse Def: Yes Now: Yes	Motor reverses when Cls PE triggered if motor closing. Next motor direction mode dependent. If set to No motor stops when Cls PE triggered, and will continue to close when Cls PE is cleared.	Yes - No	

P19 = ClsPEStopOnOpen Def: No Now: No	If set to Yes motor stops on opening when Cls PE is triggered. Next motor direction is mode dependent.	No - Yes	
P20 = Light Output Def: On Now: On	If relay is set to On - relay output is on, or Flash - relay output switches on and off. Max load 2A. P21 & P22 dependent.	On - Flash	
P21 = Light Dir Def: Opn/Cls Now: Opn/Cls	Relay output operation can be set to Opn/Cls - for full cycle or Mvmt - while gate is moving. Max load 2A.	Opn/Cls - Mvmt	
P22 = LightEndOfClsTimeOn Def: 2 Now: 2.0s	Relay closes beyond the completed close cycle, max 60 seconds	2 – 60 secs	
P23 = Aux Opn Rly Dir Def: Mov Now: Mov	Auxiliary open relay output can be set to on during movement or when open limit is activated.	Mov - Lmt	
P24 = Aux Cls Rly Dir Def: Mov Now: Mov	Auxiliary close relay output can be set to on during movement or when close limit is activated.	Mov - Lmt	
P25 = Lock Pulse Def: 1 Now: 1.0s	Set lock pulse time. <b>For magnet set to 3 seconds.</b>	0 - 3 secs	
P26 = Lock on Close Def: No Now: No	Set to Yes to activate lock/magnet at the start of the closing cycle.	No - Yes	
P27 = Lock/Magnet Def: Lok Now: Lok	Lok - for locks (power off) or Mag - for magnets (power on). <b>For magnets set LNK1</b>	Lok - Mag	
P28 = Lock Shunt Def: No Now: No	Motor 1 will move forward 1 second before opening. <b>Do not use with magnet.</b>	No - Yes	
P29 = Total Cycles # Cycles 000000	Non resettable cycle counter.	Cycle = from close to open and back to close	
P30 = Resettable Cycles # Cycles 000000	Resettable cycle counter.		
P31 = Reset Cycle Def: No Now: No	Reset resettable cycle counter.		
P32 = Reset Default Def: No Now: No	Reset all parameters P1 to P30 to default values (excludes P29).		
P33 = Software Rev. Revision X.X.	Software version		

## 8.0 JP3 OUTPUT OPTIONS

Please note all JP3 options require a plug and harness

### OPTION 1

Link 3
1 + 2

In option 1, JP3 output is compatible with all previous Liftmaster IK series control boards. JP3 can be used to start a timer (ie. garden lights) or used to provide an indicator to a monitoring system (ie. gate open or closed).

5 □	← Board status output	— Pin5 is the board status output, ON when board is active
4 □	← COM AUX relay	— Pin4 is 0V output
3 □	← +12V	— Pin3 is +12V, can be used to supply accessory max. 100mA
2 □	← NO AUX close relay	— Pin2 output is ON during closing cycle
1 □	← NO AUX open relay	— Pin1 output is ON during opening cycle

\*Option 1 is the default setting on the MB106

### OPTION 2

Link 3
2 + 3

In option 2, JP3 output can be used to control Variable Speed Drive (Inverter). The output is a DRY contact and it can be used to send an open and closed signal to any inverter.

5 □	← Board status output	— Pin5 is the board status output, ON when board is active
4 □	← COM AUX relay	— Pin4 is DRY output
3 □	← +12V	— Pin3 is +12V, can be used to supply accessory max. 100mA
2 □	← NO AUX close relay	— Pin2 output is ON during closing cycle
1 □	← NO AUX open relay	— Pin1 output is ON during opening cycle

\*Option 2 is used to configure JP3 output Pin1, Pin2 and Pin3 to dry contact output

## 9.0 JP2 OUTPUT OPTIONS

Reserved for future development, No current functions

## 10.0 LNKs

### Lock or Magnet Selection

**LNK1:** 1+2 = Lock (default setting).

2+3 = Magnet, when using magnet you must also change parameter P27 to the magnet option and wire magnet for 24VDC.

### JP3 Options

**LNK2:** 1+2 = See JP3 option 1

2+3 = See JP3 option 2







# OTHER LIFTMASTER PRODUCTS

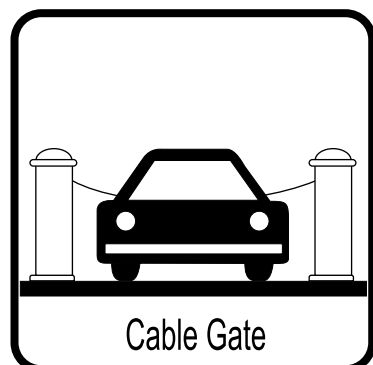
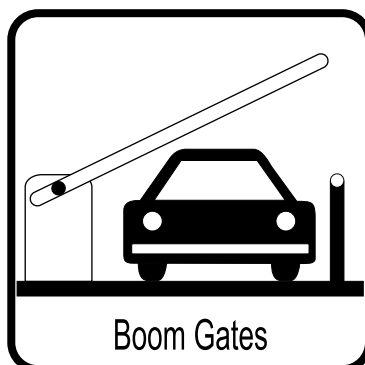
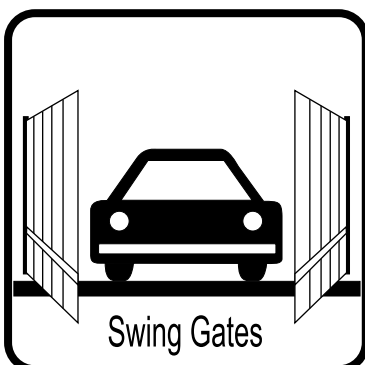
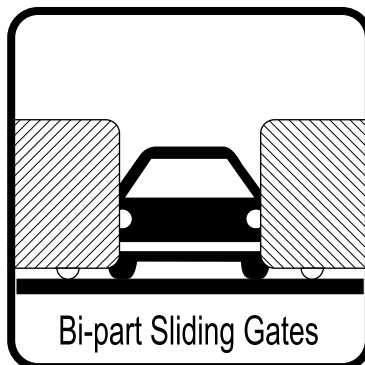
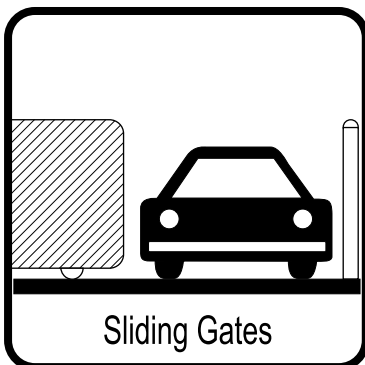
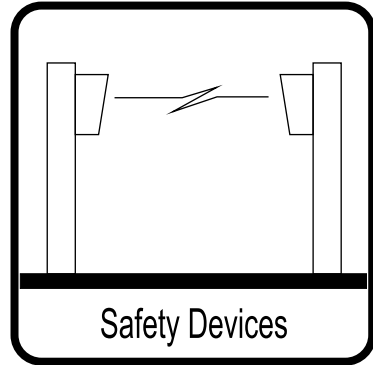
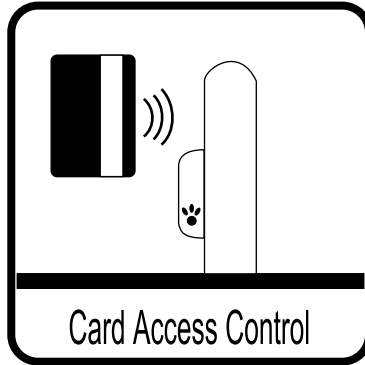
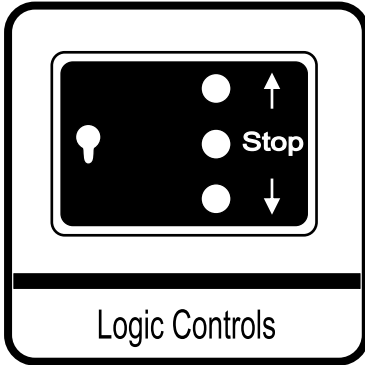

## DOMESTIC • COMMERCIAL • INDUSTRIAL

LIFTMASTER ELECTRONICS PTY LTD A.B.N. 58 000 266 035

PO BOX 54 ALEXANDRIA NSW 1435 AUSTRALIA

PH: 61 2 9699 9654 FX: 61 2 9699 8443

[www.liftmaster.com.au](http://www.liftmaster.com.au) [salesdesk@liftmaster.com.au](mailto:salesdesk@liftmaster.com.au)

As Liftmaster Electronics policy is one of constant improvement, we reserve the right to alter any part of these specifications without notice and without incurring any obligation.