

GSM Gate, Barrier, Shutter, Garage Door and Door opener

Open gate or garage door with a FREE call from your mobile phone!

Remote switching machines with a FREE call from your mobile phone!

GSM Gate Opener Remote Relay Switch



User Manual

Ver 1.5

RTU5024

Date Issued: 2015-03-25

All rights reserved

Table of contents

1. Product details -----	3
1.1 Features-----	3
1.2 Specifications-----	3
1.3 Dimensions-----	3
1.4 Standard Packing List-----	4
1.5 Applications-----	4
2. Safety Directions -----	4
3. Diagram -----	5
4. Typical Wiring Connection-----	5
5. Installation and SMS command settings -----	6
5.0 Start(Verify time)-----	7
5.1 Change password-----	7
5.2 Authorized number management-----	7
5.3 Relay control parameters-----	8
5.4 Self-check report/inquiry status/IMEI code and firmware version/RESET-----	9
6. Important information -----	10
7. Maintenance-----	10
8. Warranty -----	10
9. Authorized users list paper-----	11

This handbook has been designed as a guide to the installation and operation of RTU5024 Gate Opener. Statements contained in the handbook are general guidelines only and in no way are designed to supersede the instructions contained with other products. We recommend that the advice of a registered electrician be sought before any Installation work commences.

Caution!

Please read this user manual carefully before install/operate the Gate

Opener,basic electronic acknowledges required.

1. Product details

The RTU5024 is a powerful remote relay controller, it is a very simple device which can be used for authorized door access, controlling gates, switching of remote equipments, car parking systems. Actually the RTU5024 can be used in places which require to turn ON/OFF your system, machines, equipments remotely with a FREE call from your mobile phone.

Just dial from Authorized User number at the specified time then the Barrier and doors are opened, or the machine are turn on or off by the RTU5024. There are no call costs, the RTU5024 rejects the call from authorized number then carries out the turn ON/OFF action.

Moreover, the user can be authorized at the specified time to operate it, after timeout, will automatically change to unauthorized type.

The RTU5024 supports GPRS communication function, very suitable for remotely monitoring outdoor cabinets and stations of telecom company, traffic origination, power supply company and so on. It can be authorized different repair person or maintains person to open the cabinets or stations at the specified time, saving time to get the keys for the locks and saving cost to repair or replace the locks while the person lost the key. And also can remote monitoring the door is opened or closed, or illegal opened.

1.1 Features:

Advantages

- Quad-band, can work in the worldwide GSM Networks;
- No call charges. the GSM GPRS Relay Switch rejects the call from authorized number then carries out the turn ON/OFF action on the first 'ring';
- Multiple applications. (gates, bollards, barriers, garage doors, shutters and access doors or machines);
- Secure - Using caller-ID for identification, unknown callers are ignored;
- Can be operated from anywhere, no distance limit;
- Add or remove users by SMS Text command;
- No need to provide a remote control or keys for different users;
- Up to 200 authorized phone numbers can be configured at the specified time;
- One output with relay rating 3A/240VAC for connecting the switch of the door or machines;
- The relay action will return a SMS confirmation to the owner or authorized call-in number, this function is editable by user;
- The relay close or open time is programmable;
- Multiple applications. (gates, bollards, barriers, garage doors, shutters and access doors or machines);

Setting

- SMS command;
- Operate from anywhere anytime, no distance limitation;

1.2 Specifications

GSM Frequency	Quad-band 850/900/1800/1900MHz
Digital Output	NC/NO dry contact, 3A/240VAC
DC Power supply	9~24VDC/2A
Power consumption	12V input Max. 50mA/Average 25mA
SIM Card	Supporting 3V SIM Card
Antenna	50Ω SMA Antenna interface
Temperature range	-20~+60 °C
Humidity range	Relative humidity 90%
Backup battery	3.7V/900mAH
Exterior dimension	W102mm*D76mm*H27mm
Net Weight	180 g

1.3 Dimensions



1.4. Standard Packing List

- ✓ Gate Opener * 1
- ✓ Antenna * 1
- ✓ User Manual *1
- ✓ Packing size: 17*9.5*4 cm
- ✓ Gross Weight: 0.30kg

1.5 Applications:

- Remote open/close swing/sliding gates, doors, shutters, garage doors,locks with a free call!
- **Residential:** Door,gate,garage access control, electronic fan,microwave,air-conditioner control.
- **Industry:** Remote switch equipment, for example: street lights, solar power, motor, inverter, PLC, pumps, fans, etc.
- **Agriculture:** Remote control pumps, etc.
- **Business:** Remote control electronic boxes,bright billboards,LED signs,etc.

2.Safety Directions



Safe Startup

Do not use Gate Opener when using GSM equipment is prohibited or might bring disturbance or danger.



Interference

All wireless equipment might interfere network signals of Gate Opener and influence its performance.



Avoid Use at Gas Station

Do not use Gate Opener at a gas station. Power off Gate Opener when it near fuels or chemicals.



Power it off near Blasting Places

Please follow relevant restrictive regulations. Avoid using the device in blasting places.



Reasonable Use

Please install the product at suitable places as described in the product documentation. Avoid signal shielded by covering the mainframe.



Use Qualified Maintenance Service

Maintenance can be carried out only by qualified maintainer.

3. Diagram

INDICATORS		
Relay	ON: Relay closed(ON). OFF: Relay open(OFF)	
Signal	Flash per 0.8 second(quickly): registering to cellular network. Flash per 2 seconds: Normal status. OFF: can't connect to SIM card or unregistered to the cellular network	
Connection Terminals		
Power	+	Power supply input, Positive wire(Red).
	-	Power supply input, Negative wire(Black).
Relay Output	NO	Normally Open port
	COM	Common port
	NC	Normally Close port
ANT	Connect to GSM antenna.	

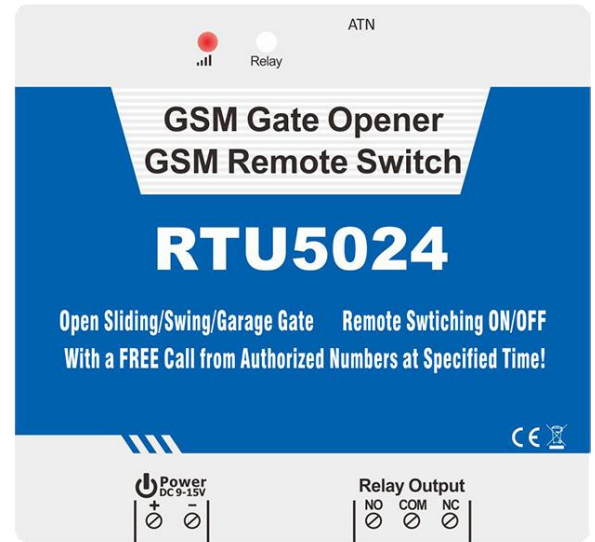

4. Typical wiring connection:



2. RTU5024 for Gate opener:

Power up the RTU5024 and electronic lock by same DC source, the lock switched ON/OFF by phone call.

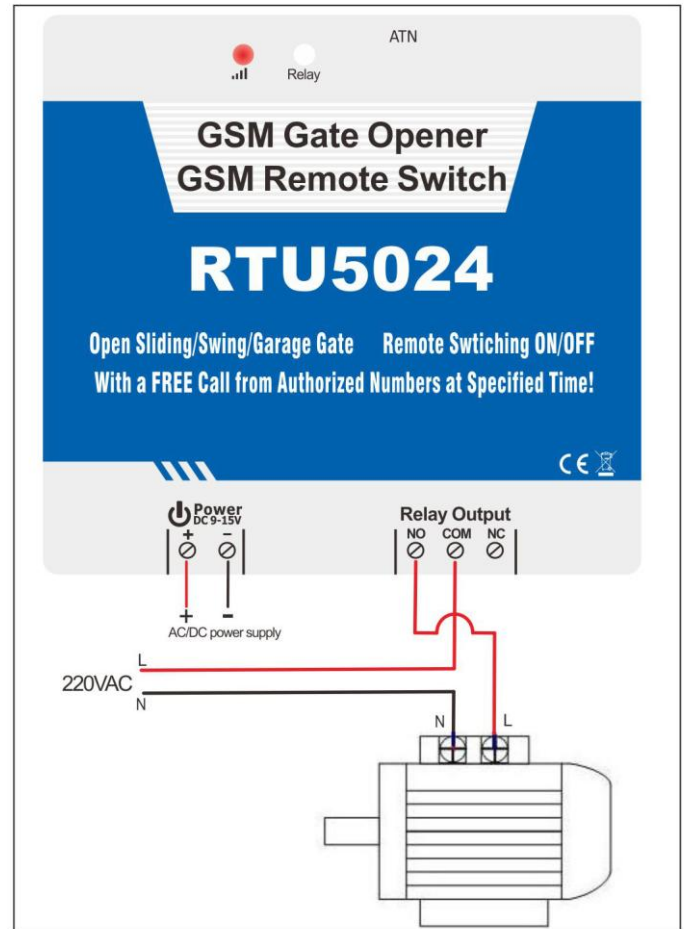

1. RTU5024 for remote switch:

The pump switched ON/OFF by phone call. Pump power up by the grid/electricity, and RTU5024 power up by AC/DC adaptor.

5. Installation and Settings

Notice:

1. The default Password is **1234**.
2. You can program the RTU5024 with SMS commands using your phone. It is safe to do so because in addition to the fact that other people may not know the number of the SIM inserted in it, we also use a Password that makes it impossible for others who doesn't know it, to access the system by chance, and all the action will be recorded.
3. The relay output will change the close or open status by every call in, please note it. Means the first time call it, it will close the relay to switch on the lock, if the second call in is in the setting time, then the unit will ignore the setting time, and open the relay, to switch off the lock.
4. Remember that commands must be **CAPITAL LETTERS**. It is AA not aa, EE not Ee etc. Don't add spaces or any other character on the SMS commands.
5. The **pwd** in the command means the password, like 1234 or 5678 if you changed.
6. If the RTU5024 used for gate access only, all you need to do is to change the default password and add the authorized numbers.
7. If you cannot call to control the RTU5024 or cannot send or receive any SMS message from it, please try to add + in front of the country code or the phone numbers:

For example:

In China, the country code is **0086** The user cell phone number is **13570810254** and has been assigned as the SMS Alert number, the simcard number in the panel is **13512345678**.

Problem 1: Alarm but the user hasn't received the SMS Alert.

Solution: Please plus the country code while you setup the 13570810254 as SMS Alert number, means setup **008613570810254** instead of the **13570810254**.

Problem 2: The user number can receive the SMS Alert message from alarm panel, but the alarm panel can not receive the commands from the user number.

Solution: Please add country code to the simcard number in the alarm panel. Means send sms commands to **008613512345678** instead of **13512345678**.

Solution 3: Use mobile phone A to call mobile phone B, the number displayed on B is which you should set as the dial number; Use mobile phone A send SMS to mobile phone B, the number displayed on B is which you should set as the SMS alert number; sometimes you may need to use the 00 to replace the + or use the + to replace the 00 on front of the country code.

8. **For security purpose, the RTU5024 will NOT return any SMS if command error, so please make sure and check the SMS Commands, or add the country code before the telephone number or check the input is in ENGLISH INPUT METHOD and CAPS LOCK.**
9. The SMS commands that you will certainly use in the RTU5024 are the following:

Installation: Open the SIM card cover on the back side of RTU5024,insert your SIM Card.

Reset: Press and hold the RESET button(closed to the SIM card holder), then power ON,after 6 seconds later, the RTU5024 will restart,then release the RESET button.

This operation will reset the password to default 1234 and other parameters, but the authorized users numbers will remain on the memory.

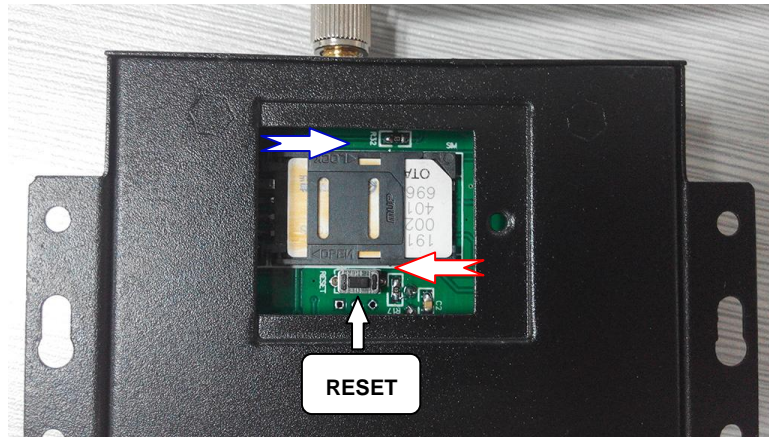

* 5.0 Start (this step is MUST):

* Send `pwdTELphone number of the RTU5024#` to the RTU5024 for adjust the time.

E.g.: `1234TEL00861351015#` if the SIM card number inside the RTU5024 is 00861351015.

RTU5024 Reply: Set Suces!

* 5.1 Change Password

`1234Pnew password`

RTU5024 return: "Password changed to"new password", please remember it carefully."if sucessfully.

E.g.: `1234P6666` for change the new password to 6666.

5.2 Authorized number managment

5.2.0 Add authorized number:

`pwdAserial number#authorized number#start time#end time#`

A:command code.

serial number: the authorized number's position, from 001~200.

start time:yy(year)mm(month)dd(day)hh(hour)mm(minute).the start time of this number can call in to control.

end time: yy(year)mm(month)dd(day)hh(hour)mm(minute).the end time of this number can call in to control.

* **Without start time and end time means: Always can call in to control.**

* E.g.: `1234A003#123456#` to set the phone no.123456 at the 3rd position and always can call in to control.

E.g.: `1234A016#123456#1502050800#1502051000#` to set the phone number 123456 at the 16th position, this number can call in to control during Feb 5th 8:00a.m.(1502050800) to Feb 5th 10:00a.m.(1502051000).

Note: 1. The authorized number means the one who can dial the RTU5024 to control the relay.

2. The Serial Number is the position to store the authorized users, from 001~200.

5.2.1 Inquiry the Authorized number's position(serial):

pwdAserial number#

E.g.: **1234A002#** to check the number on the 2nd position(serial number2).

5.2.2 Inquiry batch users number

pwdALserial number start#serial number end#

E.g.: **1234AL002#050#** to inquiry the authorized numbers from the 2nd to the 50th, RTU5024 return serval SMS with the numbers list(10 numbers on each SMS).

5.2.3 Delete the Authorized Number(or you can overwrite this postion with another number).

pwdAserial number##

E.g.: **1234A002##** to delete the 2nd authorized number.

5.3 Relay Control setting

5.3.1 Allow all numbers can call in to control:

pwdALL#

5.3.2 Allow only the authorized numbers can call in to control(Caller-ID for security,default):

*

pwdAUT#

5.3.3 How long time the relay keep close(ON) after phone call in (unit: second)

*

pwdGOTclose time#

1 Second usually

close time=000~999. Unit:Second

close time=000: relay close 0.5 second then open (use the relay as Latch).

close time=999: relay will always keep close(ON) after call in untill the next call in.

Eg: **1234GOT030#** to set relay close 30 seconds(ON) and then open(OFF) after call in.

5.3.4 Who will receive the confirmation SMS when the relay is ON/OFF

pwdGONab#content#

for relay ON,

pwdGOFFab#content#

for relay OFF.

ab: the ID code of the 1st number(a) and the caller number(b), =0 means disable, =1 means enable.

content: confirmation SMS content.

*

Only if Required

ID code		RTU5024 send notify SMS to	
a	b	The 1 st number	Caller number
0	0		
0	1		√
1	0	√	
1	1	√	√

Eg: **1234GON11#Door Open#**

The 1st number & the caller number receive confirmation SMS when relay is ON(door opened).

Eg: **1234GOFF00#Door Close#**

The 1st number & the caller number will not receive confirmation SMS when relay is OFF(door closed)..

5.3.5 No need confirmation SMS when the relay is ON/OFF.

*

pwdGON##

*

pwdGOFF##

Do both exactly like this to stop SMS Messages

5.3.6 Control the relay ON/OFF by SMS command

pwdCC

Return SMS: Relay ON (or the SMS confirmation content which you modified before)

pwdDD

Return SMS: Relay OFF(or the SMS confirmation content which you modified before)

The relay close timer according to the before setting 6.3.3:

pwdGOTclose time#

5.4 Others:

5.4.1 Self-check auto report SMS to the 1st number. (unit:hour)

pwdT#xxx#

xxx=000~999

xxx=000, default,no self-check auto report.

Auto report SMS including:

Relay status;
GSM signal value(full is 31,cellular signal weak if lower than 14)

Inquiry the self-check and auto-report time

pwdT#

5.4.2 Inquiry current status

*

pwdEE

Can do this one to check 4G Signal

5.4.3 Inquiry the GSM modules' IMEI code and firmware version

pwdIMEI#

5.4.4 RESET

Press and hold the RESET button(closed to the SIM card holder), then power ON,after 6 seconds later, the RTU5024 will restart,then release the RESET button.

This operation will reset the password to default 1234 and other parameters, but the authorized users numbers will remain on the memory.

6. Important information

- 1) Please read the User Manual carefully before you install and control the RTU5024.
- 2) Install the RTU5024 in a hidden place.
- 3) Avoid getting water into the RTU5024.
- 4) Have a secure connection to the main power supply.

7. Maintenance

- 1) In case of failure, please contact the distributor or manufacturer.
- 2) If the RTU5024 works but fail to send SMS texts, switch the power off and on again after one minute. Test it after few minutes later,or ensure and check the settings are correct and the cellular signal strong enough.
- 3) If the RTU5024 works well with sensors but cannot send SMS texts, please change a SIM Card from another Mobile Operator's, and then testing again.
- 4) Please contact the distributor or manufacturer if the problem can't solved.

8. Warranty

- 1) The RTU5024 is warranted to be free of defects in material and workmanship for one year from the date of purchase.
- 2) This warranty does not extend to any defect, malfunction or failure caused by abuse or misuse by the Operating Instructions. In no event shall the manufacturer be liable for any alarm system altered by purchasers.

The End!

Any questions please help to contact us feel free.

