

WIRING CONTINUED

OPEN, CLOSE, STOP

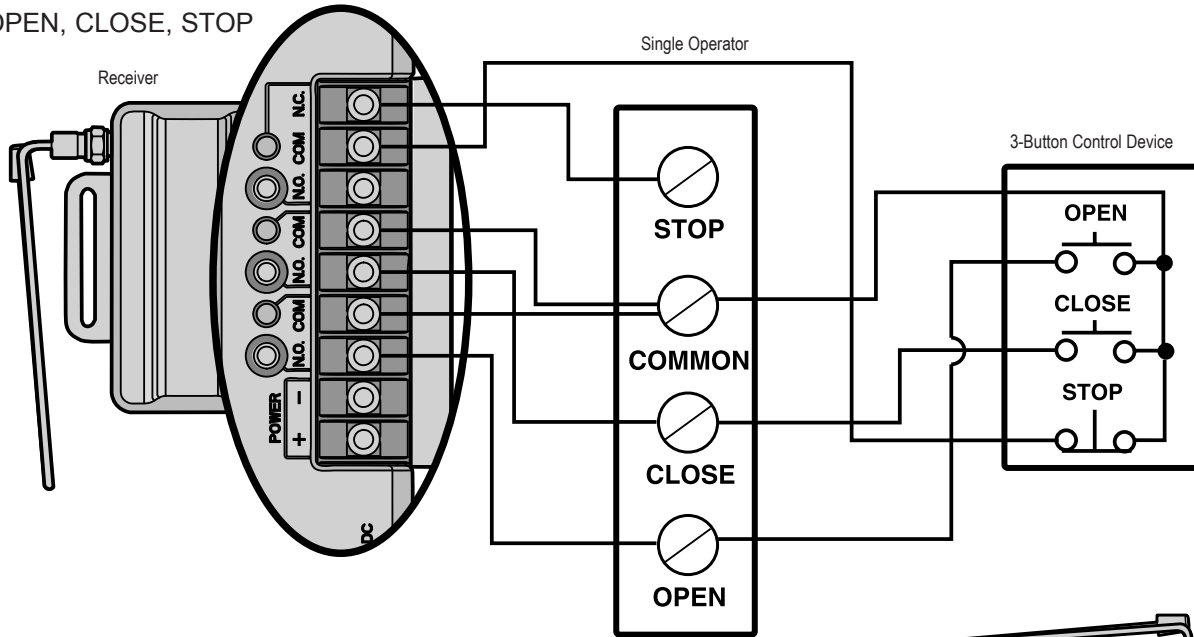

Refer to your door operator or gate operator wiring diagrams for instructions on connecting two or more 3-Button control devices.

PROGRAMMING

PROGRAM A SINGLE BUTTON REMOTE CONTROL

- 1 Press and release the Learn button for the selected channel on the receiver. The corresponding LED will glow steadily for 30 seconds.
- 2 Within 30 seconds press and hold the button on the remote control that you wish to program to the receiver.
- 3 Release the remote control button when the LED on the receiver blinks, then turns off. Programming is complete.

Repeat the steps above for each remote control you would like to program.

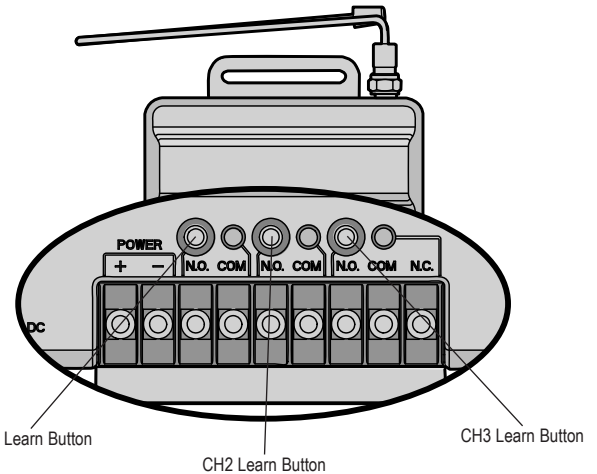

PROGRAM A 3-BUTTON REMOTE CONTROL AS OPEN, CLOSE, AND STOP

- 1 Press and release the CH1 Learn button on the receiver.
- 2 Within 30 seconds press the desired OPEN button on the remote control.
- 3 Press and release the CH2 Learn button on the receiver.
- 4 Within 30 seconds press the desired CLOSE button on the remote control.
- 5 Press and release the CH3 Learn button on the receiver.
- 6 Within 30 seconds press the desired STOP button on the remote control.

NOTE: If a remote control button is not pressed within 30 seconds, the LED next to the selected Learn button will turn OFF. In that case, repeat the programming.

TO ERASE THE MEMORY

- 1 Press and hold the Learn button for the channel you want to erase. Release the button when the corresponding LED turns off; the memory has been erased.

FOR TECHNICAL SUPPORT DIAL OUR TOLL FREE NUMBER:

1800 638 234

SPECIFICATIONS

Contact Rating 5 Amps 28 Vac or dc Max.
 Power 9-30V AC or 9-34V DC, 50mA
 RF Frequency: 433MHz

NOTE: If your operator does not meet the power specifications you will need a low voltage power supply.
 For indoor installation only.

COMPATIBLE ACCESSORIES

Remote Controls Models E945M, E940M, E943M,
 Keypads Models E840M
 Antenna Extension Kits Models 86LM,
 Antenna Only K77-36541

CHAMBERLAIN AUSTRALIA PTY LTD
 PO BOX 1446
 LANE COVE NSW 1595
 PHONE TOLL FREE: 1800 638 234

CHAMBERLAIN NEW ZEALAND LTD
 PO BOX 100-221
 NORTH SHORE 0745
 PHONE TOLL FREE: 0800 MERLIN

WWW.GO-MERLIN.COM



114A4463A