

# 740 D

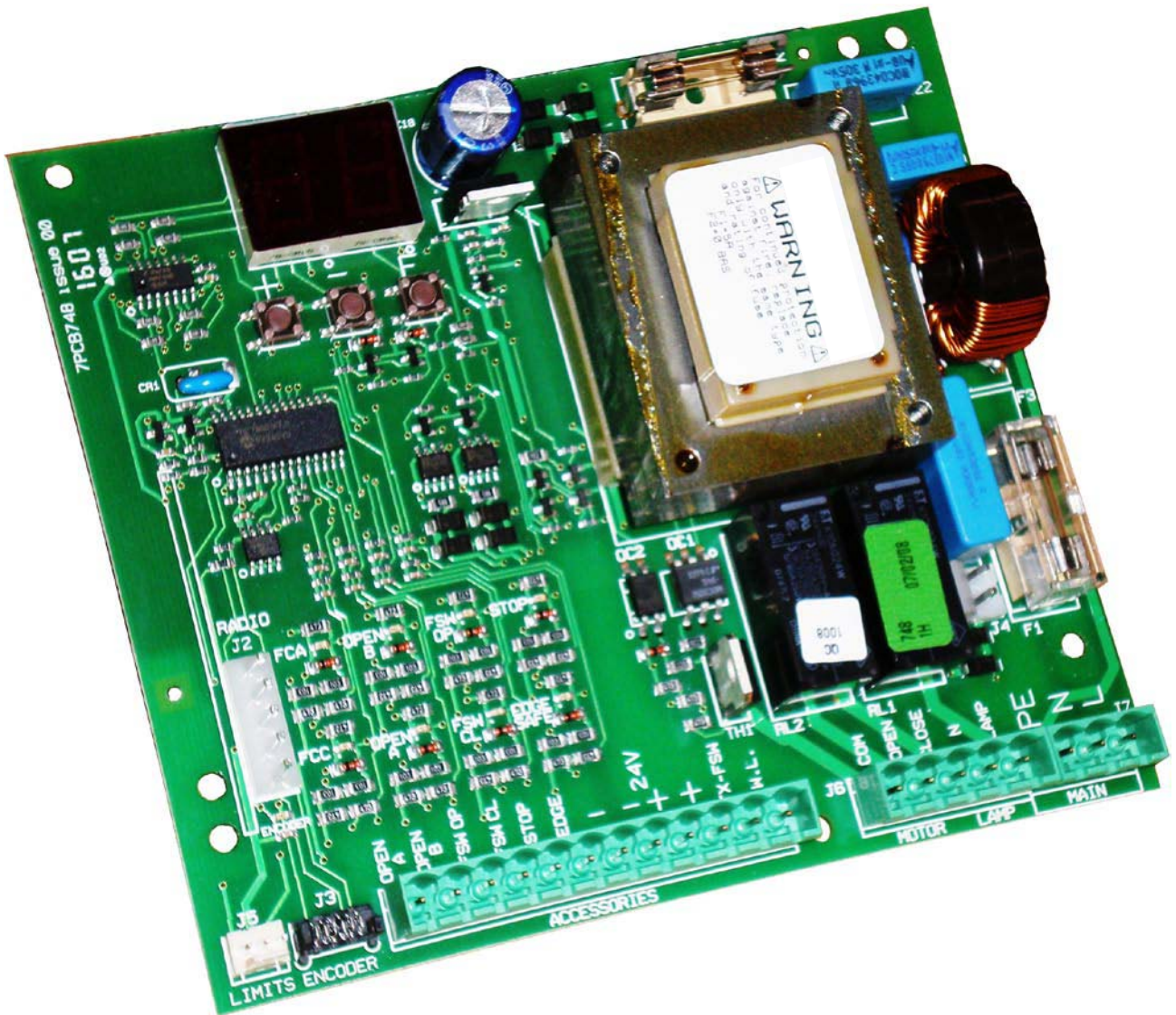

# ITALIANO

## AVVERTENZE PER L'INSTALLATORE OBBLIGHI GENERALI PER LA SICUREZZA



**ATTENZIONE!** È importante per la sicurezza delle persone seguire attentamente tutta l'istruzione. Una errata installazione o un errato uso del prodotto può portare a gravi danni alle persone.

1. Leggere attentamente le istruzioni prima di iniziare l'installazione del prodotto.
2. I materiali dell'imballaggio (plastica, polistirolo, ecc.) non devono essere lasciati alla portata dei bambini in quanto potenziali fonti di pericolo.
3. Conservare le istruzioni per riferimenti futuri.
4. Questo prodotto è stato progettato e costruito esclusivamente per l'utilizzo indicato in questa documentazione. Qualsiasi altro utilizzo non espressamente indicato potrebbe pregiudicare l'integrità del prodotto e/o rappresentare fonte di pericolo.
5. FAAC declina qualsiasi responsabilità derivata dall'uso improprio o diverso da quello per cui l'automatismo è destinato.
6. Non installare l'apparecchio in atmosfera esplosiva: la presenza di gas o fumi infiammabili costituisce un grave pericolo per la sicurezza.
7. Gli elementi costruttivi meccanici devono essere in accordo con quanto stabilito dalle Norme EN 12604 e EN 12605.
8. Per i Paesi extra-CEE, oltre ai riferimenti normativi nazionali, per ottenere un livello di sicurezza adeguato, devono essere seguite le Norme sopra riportate.
9. FAAC non è responsabile dell'inosservanza della Buona Tecnica nella costruzione delle chiusure da motorizzare, nonché delle deformazioni che dovessero intervenire nell'utilizzo.
10. L'installazione deve essere effettuata nell'osservanza delle Norme EN 12453 e EN 12445. Il livello di sicurezza dell'automazione deve essere C+D.
11. Prima di effettuare qualsiasi intervento sull'impianto, togliere l'alimentazione elettrica e scollegare le batterie.
12. Prevedere sulla rete di alimentazione dell'automazione un interruttore onnipolare con distanza d'apertura dei contatti uguale o superiore a 3 mm. È consigliabile l'uso di un magnetotermico da 6A con interruzione onnipolare.
13. Verificare che a monte dell'impianto vi sia un interruttore differenziale con soglia da 0,03 A.
14. Verificare che l'impianto di terra sia realizzato a regola d'arte e collegarvi le parti metalliche della chiusura.
15. L'automazione dispone di una sicurezza intrinseca anti-schiacciamento costituita da un controllo di coppia. E' comunque necessario verificarne le soglie di intervento secondo quanto previsto dalle Norme indicate al punto 10.
16. I dispositivi di sicurezza (norma EN 12978) permettono di proteggere eventuali aree di pericolo da Rischi meccanici di movimento, come ad Es. schiacciamento, cono-gliamento, cesoiamento.
17. Per ogni impianto è consigliato l'utilizzo di almeno una segnalazione luminosa nonché di un cartello di segnalazione fissato adeguatamente sulla struttura dell'infisso, oltre ai dispositivi citati al punto "16".
18. FAAC declina ogni responsabilità ai fini della sicurezza e del buon funzionamento dell'automazione, in caso vengano utilizzati componenti dell'impianto non di produzione FAAC.
19. Per la manutenzione utilizzare esclusivamente parti originali FAAC.
20. Non eseguire alcuna modifica sui componenti facenti parte del sistema d'automazione.
21. L'installatore deve fornire tutte le informazioni relative al funzionamento manuale del sistema in caso di emergenza e consegnare all'Utente utilizzatore dell'impianto il libretto d'avvertenze allegato al prodotto.
22. Non permettere ai bambini o persone di sostare nelle vicinanze del prodotto durante il funzionamento.
23. L'applicazione non può essere utilizzata da bambini, da persone con ridotte capacità fisiche, mentali, sensoriali o da persone prive di esperienza o del necessario addestramento.
24. Tenere fuori dalla portata dei bambini radiocomandi o qualsiasi altro datore di impulso, per evitare che l'automazione possa essere azionata involontariamente.
25. Il transito tra le ante deve avvenire solo a cancello completamente aperto.
26. L'utente utilizzatore deve astenersi da qualsiasi tentativo di riparazione o d'intervento e deve rivolgersi solo ed esclusivamente a personale qualificato FAAC o centri d'assistenza FAAC.
27. Tutto quello che non è previsto espressamente in queste istruzioni non è permesso.

# ENGLISH

## IMPORTANT NOTICE FOR THE INSTALLER GENERAL SAFETY REGULATIONS



**ATTENTION!** To ensure the safety of people, it is important that you read all the following instructions. Incorrect installation or incorrect use of the product could cause serious harm to people.

1. Carefully read the instructions before beginning to install the product.
2. Do not leave packing materials (plastic, polystyrene, etc.) within reach of children as such materials are potential sources of danger.
3. Store these instructions for future reference.
4. This product was designed and built strictly for the use indicated in this documentation. Any other use, not expressly indicated here, could compromise the good condition/operation of the product and/or be a source of danger.
5. FAAC declines all liability caused by improper use or use other than that for which the automated system was intended.
6. Do not install the equipment in an explosive atmosphere: the presence of inflammable gas or fumes is a serious danger to safety.
7. The mechanical parts must conform to the provisions of Standards EN 12604 and EN 12605.
8. For non-EU countries, to obtain an adequate level of safety, the Standards mentioned above must be observed, in addition to national legal regulations.
9. FAAC is not responsible for failure to observe Good Technique in the construction of the closing elements to be motorised, or for any deformation that may occur during use.
10. The installation must conform to Standards EN 12453 and EN 12445. The safety level of the automated system must be C+D.
11. Before attempting any job on the system, cut out electrical power and disconnect the batteries.
12. The mains power supply of the automated system must be fitted with an all-pole switch with contact opening distance of 3mm or greater. Use of a 6A thermal breaker with all-pole circuit break is recommended.
13. Make sure that a differential switch with threshold of 0.03 A is fitted upstream of the system.
14. Make sure that the earthing system is perfectly constructed, and connect metal parts of the means of the closure to it.
15. The automated system is supplied with an intrinsic anti-crushing safety device consisting

of a torque control. Nevertheless, its tripping threshold must be checked as specified in the Standards indicated at point 10.

16. The safety devices (EN 12978 standard) protect any danger areas against mechanical movement Risks, such as crushing, dragging, and shearing.
17. Use of at least one indicator-light is recommended for every system, as well as a warning sign adequately secured to the frame structure, in addition to the devices mentioned at point "16".
18. FAAC declines all liability as concerns safety and efficient operation of the automated system, if system components not produced by FAAC are used.
19. For maintenance, strictly use original parts by FAAC.
20. Do not in any way modify the components of the automated system.
21. The installer shall supply all information concerning manual operation of the system in case of an emergency, and shall hand over to the user the warnings handbook supplied with the product.
22. Do not allow children or adults to stay near the product while it is operating.
23. The application cannot be used by children, by people with reduced physical, mental, sensorial capacity, or by people without experience or the necessary training.
24. Keep remote controls or other pulse generators away from children, to prevent the automated system from being activated involuntarily.
25. Transit through the leaves is allowed only when the gate is fully open.
26. The User must not in any way attempt to repair or to take direct action and must solely contact qualified FAAC personnel or FAAC service centres.
27. Anything not expressly specified in these instructions is not permitted.

# FRANÇAIS

## CONSIGNES POUR L'INSTALLATEUR RÈGLES DE SÉCURITÉ



**ATTENTION!** Il est important, pour la sécurité des personnes, de suivre à la lettre toutes les instructions. Une installation erronée ou un usage erroné du produit peut entraîner de graves conséquences pour les personnes.

1. Lire attentivement les instructions avant d'installer le produit.
2. Les matériaux d'emballage (matière plastique, polystyrène, etc.) ne doivent pas être laissés à la portée des enfants car ils constituent des sources potentielles de danger.
3. Conservé les instructions pour les références futures.
4. Ce produit a été conçu et construit exclusivement pour l'usage indiqué dans cette documentation. Toute autre utilisation non expressément indiquée pourrait compromettre l'intégrité du produit et/ou représenter une source de danger.
5. FAAC décline toute responsabilité qui dériverait d'usage improprie ou différent de celui auquel l'automatisme est destiné.
6. Ne pas installer l'appareil dans une atmosphère explosive: la présence de gaz ou de fumées inflammables constitue un grave danger pour la sécurité.
7. Les composants mécaniques doivent répondre aux prescriptions des Normes EN 12604 et EN 12605.
8. Pour les Pays extra-CEE, l'obtention d'un niveau de sécurité approprié exige non seulement le respect des normes nationales, mais également le respect des Normes susmentionnées.
9. FAAC n'est pas responsable du non-respect de la Bonne Technique dans la construction des fermetures à motoriser, ni des déformations qui pourraient intervenir lors de l'utilisation.
10. L'installation doit être effectuée conformément aux Normes EN 12453 et EN 12445. Le niveau de sécurité de l'automatisme doit être C+D.
11. Couper l'alimentation électrique et déconnecter la batterie avant toute intervention sur l'installation.
12. Prévoir, sur le secteur d'alimentation de l'automatisme, un interrupteur onnipolaire avec une distance d'ouverture des contacts égale ou supérieure à 3 mm. On recommande d'utiliser un magnétothermique de 6A avec interruption onnipolaire.
13. Vérifier qu'il y ait, en amont de l'installation, un interrupteur différentiel avec un seuil de 0,03 A.
14. Vérifier que la mise à terre est réalisée selon les règles de l'art et y connecter les pièces métalliques de la fermeture.
15. L'automatisme dispose d'une sécurité intrinsèque anti-écrasement, formée d'un contrôle du couple. Il est toutefois nécessaire d'en vérifier le seuil d'intervention suivant les prescriptions des Normes indiquées au point 10.
16. Les dispositifs de sécurité (norme EN 12978) permettent de protéger des zones éventuellement dangereuses contre les Risques mécaniques du mouvement, comme l'écrasement, l'acheminement, le cisaillement.
17. On recommande que toute installation soit doté au moins d'une signalisation lumineuse, d'un panneau de signalisation fixé, de manière appropriée, sur la structure de la fermeture, ainsi que des dispositifs cités au point "16".
18. FAAC décline toute responsabilité quant à la sécurité et au bon fonctionnement de l'automatisme si les composants utilisés dans l'installation n'appartiennent pas à la production FAAC.
19. Utiliser exclusivement, pour l'entretien, des pièces FAAC originales.
20. Ne jamais modifier les composants faisant partie du système d'automatisme.
21. L'installateur doit fournir toutes les informations relatives au fonctionnement manuel du système en cas d'urgence et remettre à l'Usager qui utilise l'installation les "Instructions pour l'Usager" fournies avec le produit.
22. Interdire aux enfants ou aux fiers de stationner près du produit durant le fonctionnement.
23. Ne pas permettre aux enfants, aux personnes ayant des capacités physiques, mentales et sensorielles limitées ou dépourvues de l'expérience ou de la formation nécessaires d'utiliser l'application en question.
24. Eloigner de la portée des enfants les radiocommandes ou tout autre générateur d'impulsions, pour éviter tout actionnement involontaire de l'automatisme.
25. Le transit entre les vantaux ne doit avoir lieu que lorsque le portail est complètement ouvert.
26. L'utilisateur doit s'abstenir de toute tentative de réparation ou d'intervention et doit s'adresser uniquement et exclusivement au personnel qualifié FAAC ou aux centres d'assistance FAAC.
27. Tout ce qui n'est pas prévu expressément dans ces instructions est interdit.

# ESPAÑOL

## ADVERTENCIAS PARA EL INSTALADOR REGLAS GENERALES PARA LA SEGURIDAD



**ATENCIÓN!** Es sumamente importante para la seguridad de las personas seguir atentamente las presentes instrucciones. Una instalación incorrecta o un uso impropio del producto puede causar graves daños a las personas.

1. Leer detenidamente las instrucciones antes de instalar el producto.

- Los materiales del embalaje (plástico, poliestireno, etc.) no deben dejarse al alcance de los niños, ya que constituyen fuentes potenciales de peligro.
- Guarden las instrucciones para futuras consultas.
- Este producto ha sido proyectado y fabricado exclusivamente para la utilización indicada en el presente manual. Cualquier uso diverso del previsto podría perjudicar el funcionamiento del producto y/o representar fuente de peligro.
- FAAC declina cualquier responsabilidad derivada de un uso impropio o diverso del previsto.
- No instalen el aparato en atmósfera explosiva: la presencia de gas o humos inflamables constituye un grave peligro para la seguridad.
- Los elementos constructivos mecánicos deben estar de acuerdo con lo establecido en las Normas EN 12604 y EN 12605.
- Para los países no pertenecientes a la CEE, además de las referencias normativas nacionales, para obtener un nivel de seguridad adecuado, deben seguirse las Normas arriba indicadas.
- FAAC no es responsable del incumplimiento de las buenas técnicas de fabricación de los cierres que se han de motorizar, así como de las deformaciones que pudieran intervenir en la utilización.
- La instalación debe ser realizada de conformidad con las Normas EN 12453 y EN 12445. El nivel de seguridad de la automatización debe ser C+D.
- Quiten la alimentación eléctrica y desconecten las baterías antes de efectuar cualquier intervención en la instalación.
- Coloquen en la red de alimentación de la automatización un interruptor omnipolar con distancia de apertura de los contactos igual o superior a 3 mm. Se aconseja usar un magnetotérmico de 6A con interrupción omnipolar.
- Comprueben que la instalación disponga línea arriba de un interruptor diferencial con umbral de 0,03 A.
- Verifiquen que la instalación de tierra esté correctamente realizada y conecten las partes metálicas del cierre.
- La automatización dispone de un dispositivo de seguridad antiplastamiento constituido por un control de par. No obstante, es necesario comprobar el umbral de intervención según lo previsto en las Normas indicadas en el punto 10.
- Los dispositivos de seguridad (norma EN 12978) permiten proteger posibles áreas de peligro de Riesgos mecánicos de movimiento, como por ej. aplastamiento, arrastre, corte.
- Para cada equipo se aconseja usar por lo menos una señalización luminosa así como un cartel de señalización adecuadamente fijado a la estructura del bastidor, además de los dispositivos indicados en el "16".
- FAAC declina toda responsabilidad relativa a la seguridad y al buen funcionamiento de la automatización si se utilizan componentes de la instalación que no sean de producción FAAC.
- Para el mantenimiento utilicen exclusivamente piezas originales FAAC
- No efectúen ninguna modificación en los componentes que forman parte del sistema de automatización.
- El instalador debe proporcionar todas las informaciones relativas al funcionamiento del sistema en caso de emergencia y entregar al usuario del equipo el manual de advertencias que se adjunta al producto.
- No permitan que niños o personas se defiengan en proximidad del producto durante su funcionamiento.
- La aplicación no puede ser utilizada por niños, personas con reducida capacidad física, mental, sensorial o personas sin experiencia o la necesaria formación.
- Mantengan lejos del alcance los niños los telemandos o cualquier otro emisor de impulso, para evitar que la automatización pueda ser accionada involuntariamente.
- Sólo puede transitar entre las hojas si la cancela está completamente abierta.
- El usuario debe abstenerse de intentar reparar o de intervenir directamente, y debe dirigirse exclusivamente a personal cualificado FAAC o a centros de asistencia FAAC.
- Todo lo que no esté previsto expresamente en las presentes instrucciones debe entenderse como no permitido

## DEUTSCH

### HINWEISE FÜR DEN INSTALLATIONSTECHNIKER ALLGEMEINE SICHERHEITSVORSCHRIFTEN



**ACHTUNG!** Um die Sicherheit von Personen zu gewährleisten, sollte die Anleitung aufmerksam befolgt werden. Eine falsche Installation oder ein fehlerhafter Betrieb des Produktes können zu schwerwiegenden Personenschäden führen.

- Bevor mit der Installation des Produktes begonnen wird, sollten die Anleitungen aufmerksam gelesen werden.
- Das Verpackungsmaterial (Kunststoff, Styropor, usw.) sollte nicht in Reichweite von Kindern aufbewahrt werden, da es eine potentielle Gefahrenquelle darstellt.
- Die Anleitung sollte aufbewahrt werden, um auch in Zukunft Bezug auf sie nehmen zu können.
- Dieses Produkt wurde ausschließlich für den in diesen Unterlagen angegebenen Gebrauch entwickelt und hergestellt. Jeder andere Gebrauch, der nicht ausdrücklich angegeben ist, könnte die Unversehrtheit des Produktes beeinträchtigen und/oder eine Gefahrenquelle darstellen.
- Die Firma FAAC lehnt jede Haftung für Schäden, die durch unsachgemäße oder nicht bestimmungsgemäße Gebrauch der Automatik verursacht werden, ab.
- Das Gerät sollte nicht in explosionsgefährdeten Umgebungen installiert werden: das Vorhandensein von entflammaren Gasen oder Rauch stellt ein schwerwiegendes Sicherheitsrisiko dar.
- Die mechanischen Bauelemente müssen den Anforderungen der Normen EN 12604 und EN 12605 entsprechen.
- Für Länder, die nicht der Europäischen Union angehören, sind für die Gewährleistung eines entsprechenden Sicherheitsniveaus neben den nationalen gesetzlichen Bezugsvorschriften die oben aufgeführten Normen zu beachten.
- Die Firma FAAC übernimmt keine Haftung im Falle von nicht fachgerechten Ausführungen bei der Herstellung der anzutreibenden Schließvorrichtungen sowie bei Deformationen, die eventuell beim Betrieb entstehen.
- Die Installation muß unter Beachtung der Normen EN 12453 und EN 12445 erfolgen. Die Sicherheitsstufe der Automatik sollte C+D sein.
- Vor der Ausführung jeglicher Eingriffe auf der Anlage sind die elektrische Versorgung und die Batterie abzunehmen.
- Auf dem Versorgungsnetz der Automatik ist ein omnipolarer Schalter mit Öffnungsabstand der Kontakte von über oder gleich 3 mm einzubauen. Darüber hinaus wird der Einsatz eines Magnetschutzschalters mit 6A mit omnipolarer Abschaltung empfohlen. Es sollte überprüft werden, ob vor der Anlage ein Differentialschalter mit einer Auslöseschwelle von 0,03 A zwischengeschaltet ist.
- Es sollte überprüft werden, ob die Erdungsanlage fachgerecht ausgeführt wurde. Die Metallteile der Schließung sollten an diese Anlage angeschlossen werden.
- Die Automation verfügt über eine eingebaute Sicherheitsvorrichtung für den Quetschschutz, die aus einer Drehmomentkontrolle besteht. Es ist in jedem Falle erforderlich, deren Eingriffsschwelle gemäß der Vorgaben der unter Punkt 10 angegebenen Vorschriften zu überprüfen.
- Die Sicherheitsvorrichtungen (Norm EN 12978) ermöglichen den Schutz eventueller Gefahrenbereiche vor mechanischen Bewegungsrisiken, wie zum Beispiel Quetschungen,

Mitschleifen oder Schnittverletzungen.

- Für jede Anlage wird der Einsatz von mindestens einem Leuchtsignal empfohlen sowie eines Hinweisschildes, das über eine entsprechende Befestigung mit dem Aufbau des Tors verbunden wird. Darüber hinaus sind die unter Punkt "16" erwähnten Vorrichtungen einzusetzen.
- Die Firma FAAC lehnt jede Haftung hinsichtlich der Sicherheit und des störungsfreien Betriebs der Automatik ab, soweit Komponenten auf der Anlage eingesetzt werden, die nicht im Hause FAAC hergestellt wurden.
- Bei der Instandhaltung sollten ausschließlich Originalteile der Firma FAAC verwendet werden.
- Auf den Komponenten, die Teil des Automationsystems sind, sollten keine Veränderungen vorgenommen werden.
- Der Installateur sollte alle Informationen hinsichtlich des manuellen Betriebs des Systems in Notfällen liefern und dem Betreiber der Anlage das Anleitungsbuch, das dem Produkt beigelegt ist, übergeben.
- Weder Kinder noch Erwachsene sollten sich während des Betriebs in der unmittelbaren Nähe der Automation aufhalten.
- Die Anwendung darf nicht von Kindern, von Personen mit verminderter körperlicher, geistiger, sensorischer Fähigkeit oder Personen ohne Erfahrungen oder der erforderlichen Ausbildung verwendet werden.
- Die Funksteuerungen und alle anderen Impulsgeber sollten außerhalb der Reichweite von Kindern aufbewahrt werden, um ein versehentliches Aktivieren der Automation zu vermeiden.
- Der Durchgang oder die Durchfahrt zwischen den Flügeln darf lediglich bei vollständig geöffnetem Tor erfolgen.
- Der Benutzer darf direkt keine Versuche für Reparaturen oder Arbeiten vornehmen und hat sich ausschließlich an qualifiziertes Fachpersonal FAAC oder an Kundendienstzentren FAAC zu wenden.
- Alle Vorgehensweisen, die nicht ausdrücklich in der vorliegenden Anleitung vorgesehen sind, sind nicht zulässig

## NEDERLANDS

### WAARSCHUWINGEN VOOR DE INSTALLATEUR ALGEMENE VEILIGHEIDSVORSCHRIFTEN



**LET OPI!** Het is belangrijk voor de veiligheid dat deze hele instructie zorgvuldig wordt opgevolgd. Een onjuiste installatie of foutief gebruik van het product kunnen ernstig persoonlijk letsel veroorzaken.

- Lees de instructies aandachtig door alvorens te beginnen met de installatie van het product.
- De verpakkingsmaterialen (plastic, polystyreen, enz.) mogen niet binnen het bereik van kinderen worden gelaten, want zij vormen een mogelijke bron van gevaar.
- Bewaar de instructies voor raadpleging in de toekomst.
- Dit product is uitsluitend ontworpen en gebouwd voor het doel dat in deze documentatie wordt aangegeven. Elk ander gebruik, dat niet uitdrukkelijk wordt vermeld, zou het product kunnen beschadigen en/of een bron van gevaar kunnen vormen.
- FAAC aanvaardt geen enkele aansprakelijkheid voor schade die voortvloeit uit oneigenlijk gebruik of ander gebruik dan waarvoor het automatische systeem is bedoeld.
- Installeer het apparaat niet in een explosiegevaarlijke omgeving: de aanwezigheid van ontvlambare gassen of dampen vormt een ernstig gevaar voor de veiligheid.
- De mechanische bouwonderdelen moeten in overeenstemming zijn met de bepalingen van de normen EN 12604 en EN 12605.
- Voor niet-EEG landen moeten, om een goed veiligheidsniveau te bereiken, behalve de nationale voorschriften ook de bovenstaande normen in acht worden genomen.
- FAAC is niet aansprakelijk als de regels der goede techniek niet in acht genomen zijn bij de bouw van het sluitwerk dat gemotoriseerd moet worden, noch voor vervormingen die zouden kunnen ontstaan bij het gebruik.
- De installatie dient te geschieden in overeenstemming met de normen EN 12453 en EN 12445. Het veiligheidsniveau van het automatische systeem moet C+D zijn.
- Alvorens ingrepen te gaan verrichten op de installatie moet de elektrische voeding worden weggenomen en moeten de batterijen worden afgekoppeld.
- Zorg op het voedingsnet van het automatische systeem voor een meerpolige schakelaar met een opening tussen de contacten van 3 mm of meer. Het wordt geadviseerd een magnetothermische schakelaar van 6A te gebruiken met meerpolige onderbreking.
- Controleer of er bovenstrooms van de installatie een differentieel schakelaar is geplaatst met een limiet van 0,03 A.
- Controleer of de aardingsinstallatie vakkundig is aangelegd en sluit er de metalen delen van het sluitsysteem op aan.
- Het automatische systeem beschikt over een intrinsieke beveiliging tegen inklemming, bestaande uit een controle van het koppel. De inschakelmoment hiervan dient echter te worden gecontroleerd volgens de bepalingen van de normen die worden vermeld onder punt 10.
- De veiligheidsvoorzieningen (norm EN 12978) maken het mogelijk eventuele gevaarlijke gebieden te beschermen tegen Mechanische gevaren door beweging, zoals bijvoorbeeld inklemming, meesleuren of amputatie.
- Het wordt voor elke installatie geadviseerd minstens één lichtsignaal te gebruiken alsook een waarschuwingsbord dat goed op de constructie van het hang- en sluitwerk dient te worden bevestigd, afgezien nog van de voorzieningen die genoemd zijn onder punt "16".
- FAAC aanvaardt geen enkele aansprakelijkheid voor wat betreft de veiligheid en de goede werking van het automatische systeem, als er in de installatie gebruik gemaakt wordt van componenten die niet door FAAC zijn geproduceerd.
- Gebruik voor het onderhoud uitsluitend originele FAAC-onderdelen.
- Verricht geen wijzigingen op componenten die deel uitmaken van het automatische systeem.
- De installateur dient alle informatie te verstrekken over de handbediening van het systeem in noodgevallen, en moet de gebruiker van de installatie het bij het product geleverde boekje met aanwijzingen overhandigen.
- De toepassing mag niet worden gebruikt door kinderen, personen met lichamelijke, geestelijke en sensoriele beperkingen, of door personen zonder ervaring of de benodigde training.
- Sta het niet toe dat kinderen of volwassenen zich ophouden in de buurt van het product terwijl dit in werking is.
- Houd radio-afstandsbedieningen of alle andere impulsgevers buiten het bereik van kinderen, om te voorkomen dat het automatische systeem onopzettelijk kan worden aangedreven.
- Ga alleen tussen de vleugels door als het hek helemaal geopend is.
- De gebruiker mag zelf geen pogingen ondernemen tot reparaties of andere directe ingrepen, en dient zich uitsluitend te wenden tot gekwalificeerd en geautoriseerd FAAC-personeel of een erkend FAAC-servicecentrum.
- Alles wat niet uitdrukkelijk in deze instructies wordt aangegeven, is niet toegestaan

# INDEX

1. WARNINGS	page.12
2. TECHNICAL SPECIFICATIONS	page.12
3. LAYOUT AND COMPONENTS	page.12
4. ELECTRIC CONNECTIONS	page.12
4.1. Connection of photocells and safety devices	page.13
4.2. J7 Terminal board - Power supply (fig. 2)	page.14
4.3. J6 Terminal board - Motors and flashing lamp (fig. 2)	page.14
4.4. J1 Terminal board - Accessories (fig. 2)	page.14
4.5. Connector J2 - Rapid connection to Minidec, Decoder and RP	page.15
4.6. Connector J6 - Limit-switches rapid connection (fig.2)	page.15
4.7. Connector J3 - Encoder rapid connection (fig.2)	page.15
5. PROGRAMMING	page.16
5.1. BASIC PROGRAMMING	page.16
5.2. ADVANCED PROGRAMMING	page.16
6. START-UP	page.17
6.1. INPUTS CHECK	page.17
7. AUTOMATED SYSTEM TEST	page.17

## CE DECLARATION OF CONFORMITY

**Manufacturer:** FAAC S.p.A.

**Address:** Via Benini, 1 - 40069 - Zola Predosa- BOLOGNA - ITALY

**Declares that:** Control unit model **740 D** powered on 230 Vac

- conforms to the essential safety requirements of the following EEC directives:
  - 2006/95/EC Low Voltage directive.
  - 2004/108/EC Electromagnetic Compatibility directive.

**Additional information:**



**This product underwent a test in a typical uniform configuration (all products manufactured by FAAC S.p.A.).**

Bologna, 28-02-2008

Mandating Director  
A. Bassi

**Notes on reading the instruction**

**Read this installation manual to the full before you begin installing the product.**

The symbol  indicates notes that are important for the safety of persons and for the good condition of the automated system.  
The symbol  draws your attention to the notes on the characteristics and operation of the product.

# CONTROL BOARD 740 D

## 1. WARNINGS



Before attempting any work on the control board (connections, maintenance), always turn off power.

Install, upstream of the system, a differential thermal breaker with adequate tripping threshold.

Connect the earth cable to the appropriate terminal on the J7 connector of the equipment (see fig.2).

Always separate power cables from control and safety cables (push-button, receiver, photocells, etc.). To avoid any electric noise, use separate sheaths or a shielded cable (with earthed shield).

## 2. TECHNICAL SPECIFICATIONS

<b>Power supply (+6% -10% V)</b>	230 V ~ - 50 Hz	<b>(115 V ~ - 60 Hz*)</b>
<b>Absorbed power</b>	10 W	<b>(10 W*)</b>
<b>Motor max. load</b>	1000 W	<b>(1200 W*)</b>
<b>Accessories max. load</b>	0,5 A	<b>(0.5 A*)</b>
<b>Operating ambient temperature</b>	-20 °C +55 °C	
<b>Protection fuses</b>	2 (see fig. 1)	
<b>Function logics</b>	Automatic / "Stepped" automatic / Semi-automatic / Safety devices / Semi-automatic B / Dead-man C / "Stepped" semi-automatic / Mixed Log. B+C	
<b>Work time</b>	Programmable (from 0 to 4 min.)	
<b>Pause time</b>	Programmable (from 0 to 4 min.)	
<b>Thrust force</b>	Adjustable over 50 levels	
<b>Terminal board inputs</b>	Open / Partial opening / Safety devices at opng. / Safety devices at clng. / Stop / Edge / Power supply + Earth	
<b>On-connector inputs</b>	Opening and closing limit-switches / Encoder	
<b>Terminal board outputs</b>	Flashing lamp - Motor - 24 Vdc accessories power supply - 24 Vdc indicator-light / Timed output. - Fail safe	
<b>Rapid connector</b>	5-pin card connection for Minidec, Decoder or RP receivers	
<b>Programming</b>	3 keys (+, -, F) and display, "basic" or "advanced" mode	
<b>Basic mode programmable functions</b>	Function logic - Pause time - Thrust Force - Gate direction	
<b>Advanced mode programmable functions</b>	Torque at initial thrust - Braking - Fail safe - Pre-flashing - Indicator-light/Timed output - Opening and closing safety devices logic - Encoder - Decelerations - Partial opening time - Work time - Assistance request - Cycle counter	

## 3. LAYOUT AND COMPONENTS

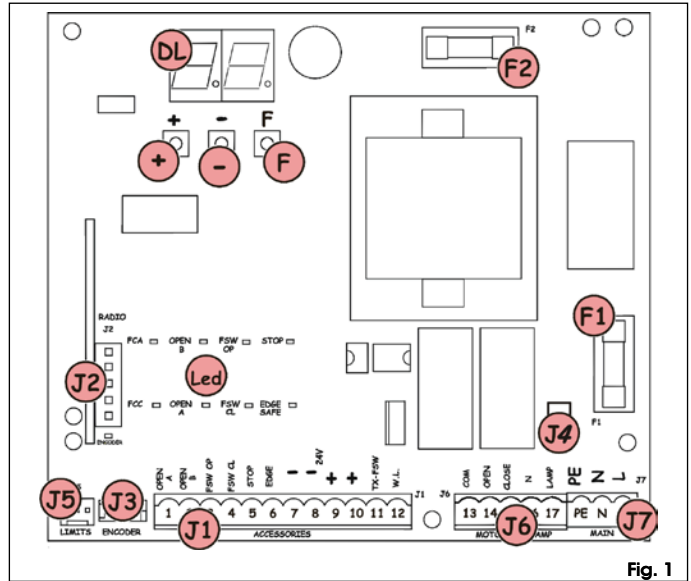

Fig. 1

<b>DL</b>	SIGNALLING AND PROGRAMMING DISPLAY
<b>Led</b>	INPUTS STATUS CONTROL LED
<b>J1</b>	LOW VOLTAGE TERMINAL BOARD
<b>J2</b>	CONNECTOR FOR DECODER/MINIDEC/RP RECEIVER
<b>J3</b>	ENCODER CONNECTOR
<b>J4</b>	CAPACITOR CONNECTOR
<b>J5</b>	LIMIT -SWITCH CONNECTOR
<b>J6</b>	MOTORS AND FLASHING LAMP CONNECTION TERMINAL BOARD
<b>J7</b>	POWER SUPPLY TERMINAL BOARD 230Vac <b>(115Vac*)</b>
<b>F1</b>	MOTORS AND TRANSF. PRIMARY FUSE (F 5A) <b>(F 10A*)</b>
<b>F2</b>	LOW VOLTAGE AND ACCESSORIES FUSE (T 800mA)
<b>F</b>	"F" PROGRAMMING PUSH-BUTTON
<b>-</b>	"-" PROGRAMMING PUSH-BUTTON
<b>+</b>	"+" PROGRAMMING PUSH-BUTTON

\* 740D 115V

## 4. ELECTRIC CONNECTIONS

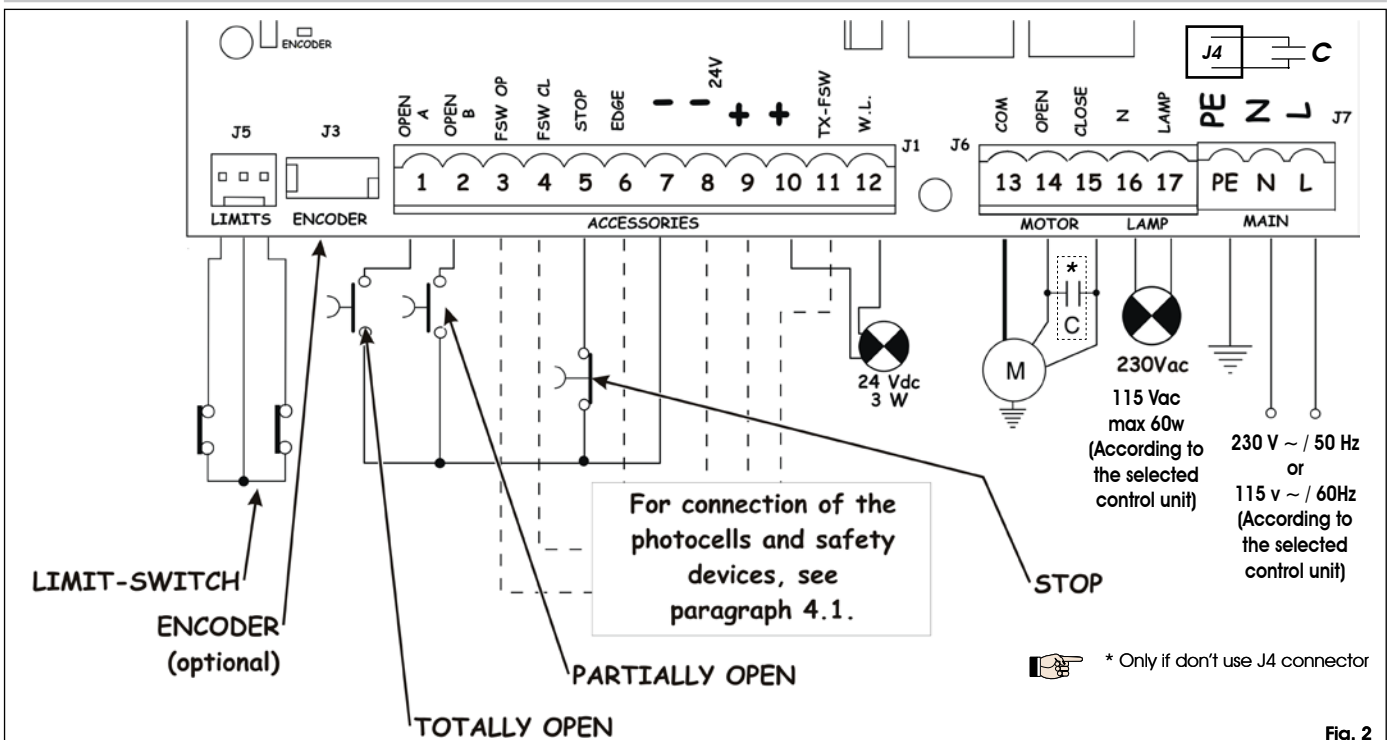

Fig. 2

ENGLISH

#### 4.1. Connection of photocells and safety devices

Before connecting the photocells (or other devices) we advise you to select the type of operation according to the movement area they have to protect (see fig.3):

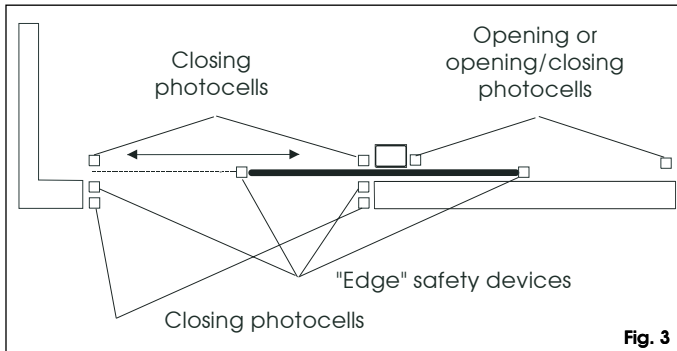

Fig. 3

- **Opening safety devices:** they operate only during the gate opening movement and, therefore, they are suitable for protecting the area between the opening leaf and fixed obstacles (walls, etc) against the risk of impact and crushing.
- **Closing safety devices:** they operate only during the gate closing movement and, therefore, they are suitable for protecting the closing area against the risk of impact.
- **Opening/closing safety devices:** they operate during the gate opening and closing movements and, therefore, they are suitable for protecting the opening and closing areas against the risk of impact.
- **"Edge" safety devices:** they operate during the gate opening and closing movements and, therefore, they are suitable for protecting the areas between the moving leaf and fixed obstacles (pillars, walls, etc) against the risk of shearing and dragging.
- **Encoder (optional):** operates during the gate opening and closing movements and, therefore, it is suitable for protecting the opening and closing area against the risk of impact, crushing, shearing and dragging.

If two or more safety devices have the same function (opening, closing, opening and closing, edge), the contacts must be connected to each other in series (fig. 4). N.C. contacts must be used.

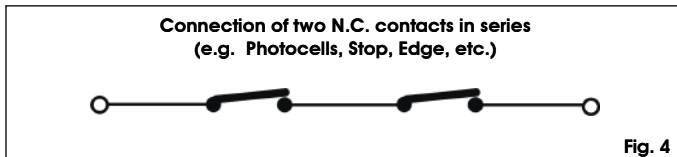

Fig. 4

If safety devices are not used, jumper connect the terminals as shown in fig. 5.

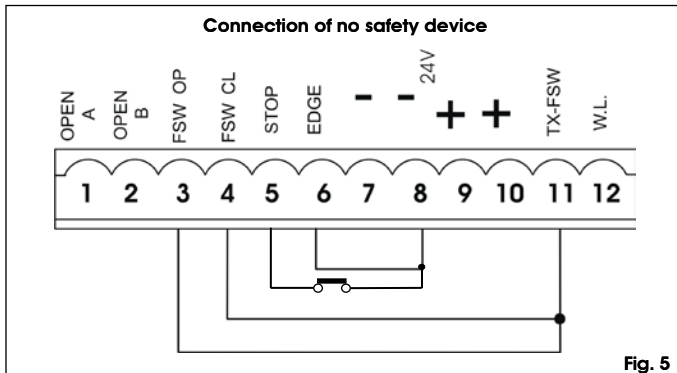

Fig. 5

The most common photocell and safety device lay-outs are shown below (from fig. 6 to fig. 13).

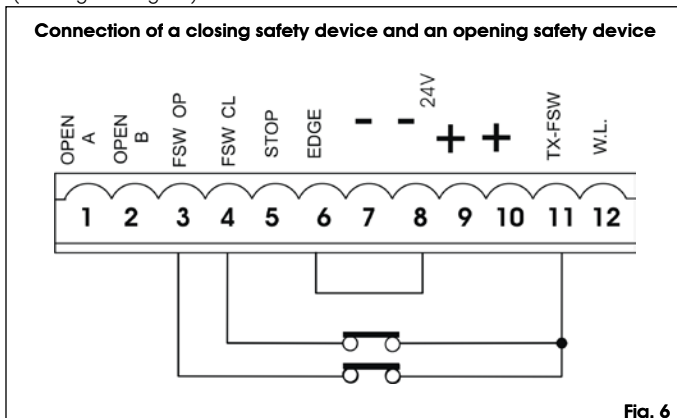

Fig. 6

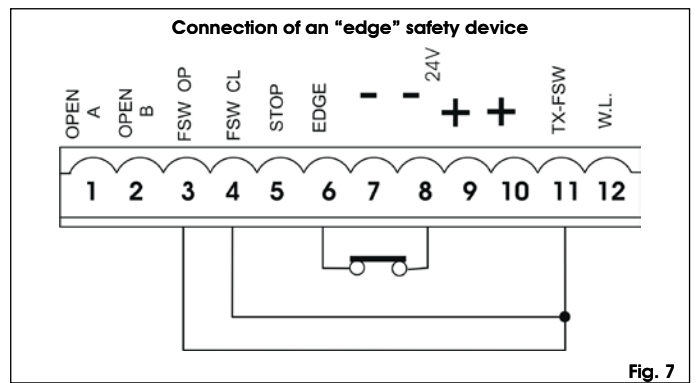

Fig. 7

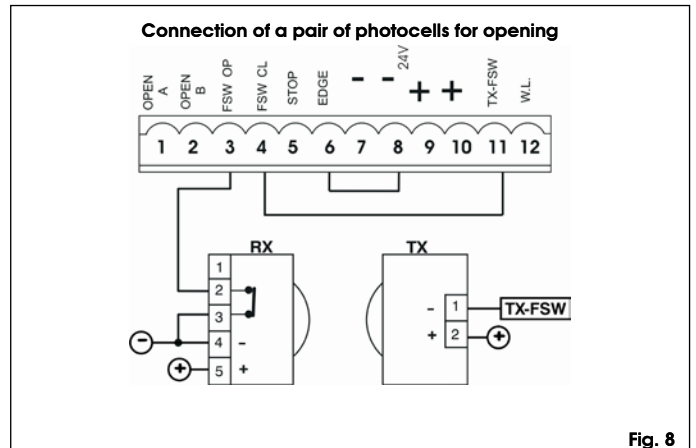

Fig. 8

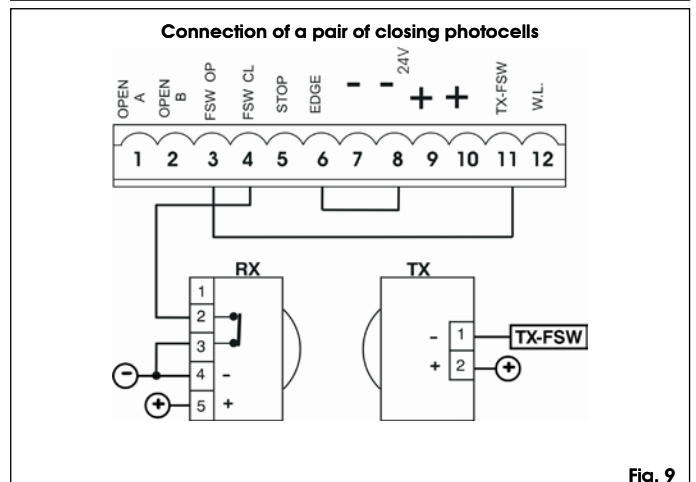

Fig. 9

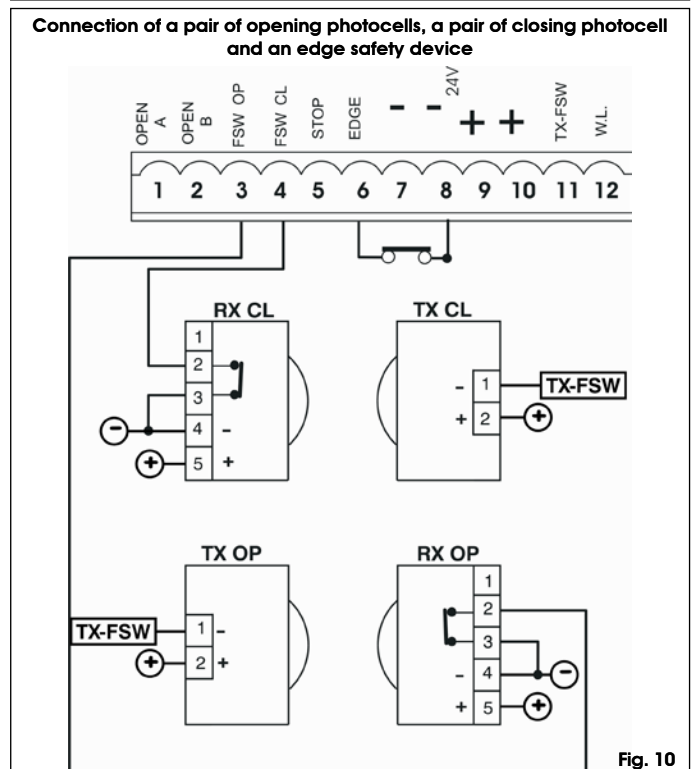
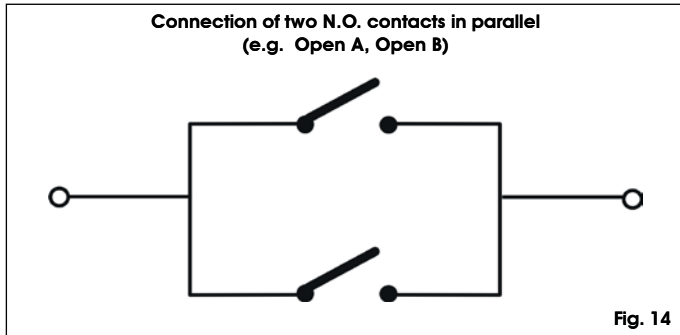
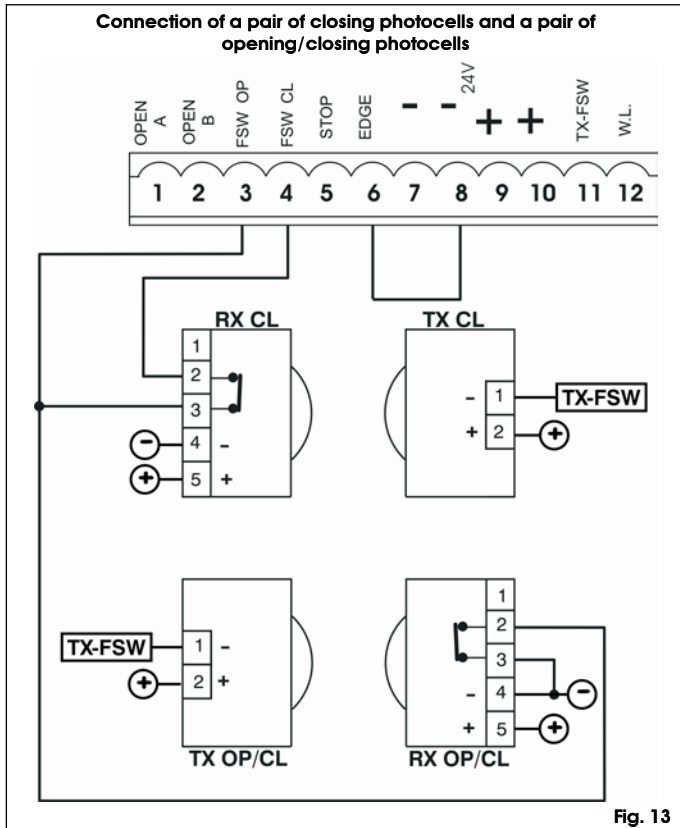
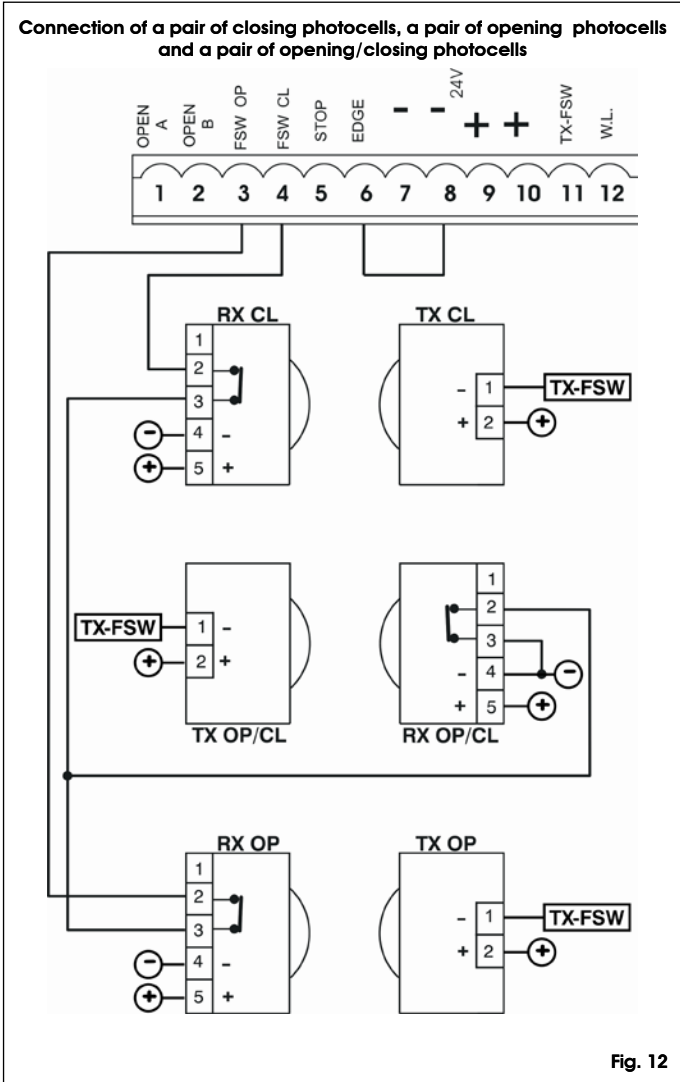
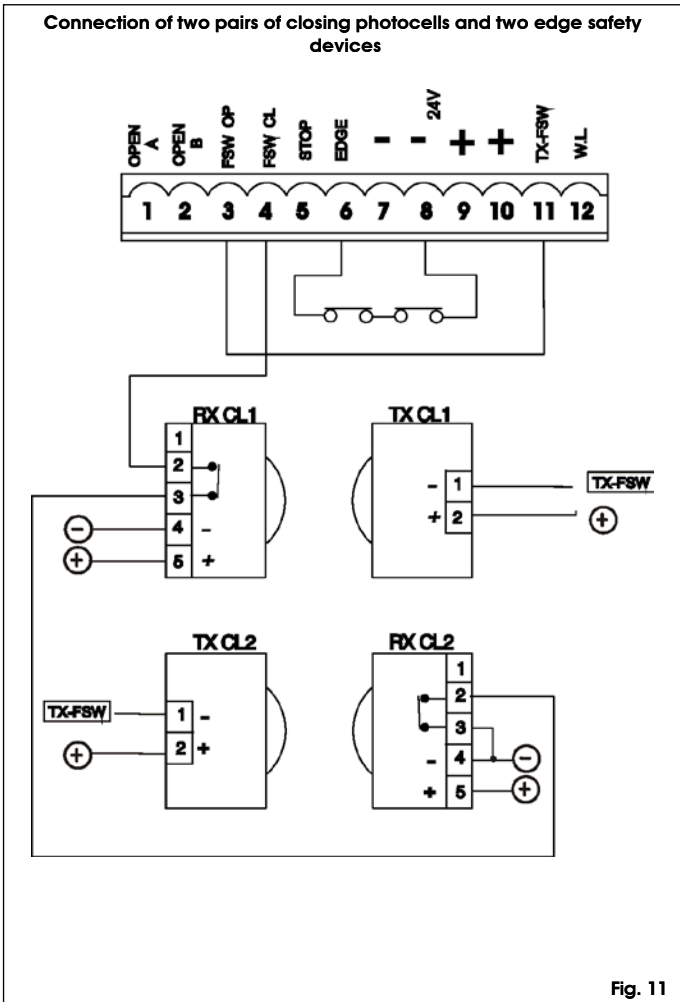

Fig. 10



4.2. J7 Terminal board - Power supply (fig. 2)

POWER SUPPLY (TERMINALS PE-N-L):

- PE: Earth connection
- N: 230 V~ power supply ( Neutral )
- L: 230 V~ power supply ( Line )

For correct operation, the board must be connected to the earth conductor in the system. Install an adequate differential thermal breaker upstream of the system.

4.3. J6 Terminal board - Motors and flashing lamp (fig. 2)

- **MOTOR** - (terminals 13-14-15): Motor connection. In gearmotors with a built-in control unit, this connection is pre-wired standard. PFor leaf opening direction, see basic programming in Chpt 5.1.
- **LAMP** - (terminals 16 -17): Flashing lamp output ( 230 V ~)

4.4. J1 Terminal board - Accessories (fig. 2)

- **OPEN A** - "Total Opening" command (terminal 1): any pulse generator (push-button, detector, etc.) which, by closing a contact, commands total opening and/or closing of the gate leaf.
- To install several total opening pulse generators, connect the N.O. contacts in parallel (see fig. 14).
- **OPEN B** - "Partial opening " or "Closing" command (terminal 2): any pulse generator (push-button, detector, etc.) which, by closing a contact, commands partial opening and/or closing of the gate leaf. In the B and C logics, it always commands gate closure.
- To install several partial opening pulse generators, connect the N.O. contacts in parallel (see fig. 14).

• **FSW OP - Opening safety devices contact (terminal 3):** The purpose of the opening safety devices is to protect the leaf movement area during opening. During opening, in the A-AP-S-E-EP logics the safety devices reverse the movement of the gate leaves, or stop and restart the movement when they are released (see advanced programming in Chpt 5.2). During the opening cycle in logics B and C, they interrupt movement. They never operate during the closing cycle.

 If the Opening safety devices are engaged when the gate is closed, they prevent the leaf opening movement.

 To install several safety devices, connect the N.C. contacts in series (fig.4).

 If no opening safety devices are connected, jumper connect inputs OP and -TX FSW (fig. 5).

• **FSW CL - Closing safety devices contact (terminal 4):** The purpose of the closing safety devices is to protect the leaf movement area during closing. During closing, in the A-AP-S-E-EP logics, the safety devices reverse the movement of the gate leaves, or stop and reverse the movement when they are released (see advanced programming in Chpt 5.2). During the closing cycle in logics B and C, they interrupt movement. They never operate during the opening cycle.

 If the Closing safety devices are engaged when the gate is open, they prevent the leaf closing movement.

To install several safety devices, connect the N.C. contacts in series (fig.4).

 If no closing safety devices are connected, jumper connect terminals CL and -TX FSW (fig. 5).

• **STOP - STOP contact (terminal 5):** any device (e.g. a push-button) which, by opening a contact, is able to stop gate movement.

 To install several STOP devices, connect the N.C. contacts in series.

 If STOP devices are not connected, jumper connect the STP and - terminals.

• **EDGE - EDGE safety device contact (terminal 6):** The purpose of the "edge" safety device is to protect the leaf movement area during opening/closing against fixed obstacles (pillars, walls, etc.). In all logics, during opening and closing, the safety devices reverse gate leaf movement for 2 seconds. If the safety devices operate again during the 2-seconds reversing time, they STOP movement without any reversing.

 If the Edge safety devices are engaged while the gate is closed or open, they prevent the leaves movement.

To install several safety devices, connect the N.C. contacts in series (fig.4).

 If edge safety devices are not connected, jumper connect the EDGE and - inputs. (fig. 5).

• - **Negative for power supply to accessories (terminals 7 and 8)**  
 • + **24 Vdc - Positive for power supply to accessories (terminals 9 and 10)**

 Accessories max. load is 500 mA. To calculate absorption values, refer to the instructions for individual accessories.

• **TX - FSW - Negative for power supply to photocell transmitters (terminal 11)**  
 If you use this terminal for connecting the negative for supplying power to the photocell transmitters, you may, if necessary, also use the FAIL SAFE function (see advanced programming in Chpt 5.2). If this function is enabled, the equipment checks operation of the photocells before every opening or closing cycle.

• **W.L. - Power supply to indicator-light / timed output (terminal 12)**  
 Connect a 24 Vdc - 3 W max indicator-light or timed output, if necessary, between this terminal and the +24V supply (see advanced programming in Chpt 5.2).

 To avoid jeopardising correct operation of the system, do not exceed the indicated power.

4.5. Connector J2 - Rapid connection to Minidec, Decoder and RP

This is used for rapid connection of Minidec, Decoder and RP receivers (see fig. 15, 16 and 17). Connect the accessory, with the components side facing the inside of the board. Insert and remove after cutting power.

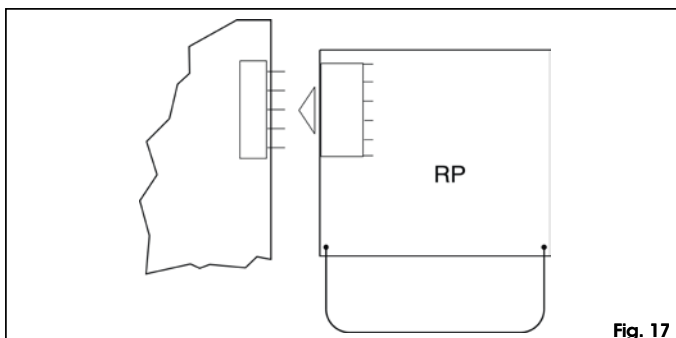
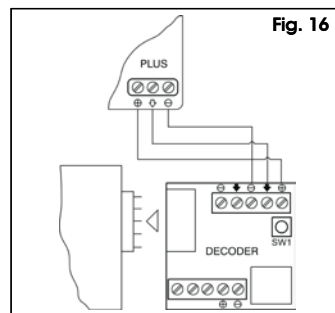
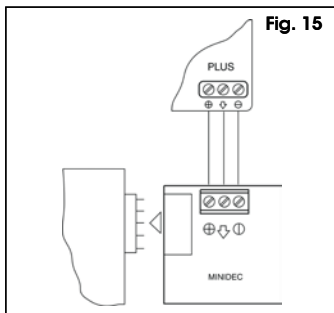

4.6. Connector J6 - Limit-switches rapid connection (fig.2)

This input is intended for rapid connection of the opening and closing limit-switches designed to stop the leaf, or for start of decelerations or for braking (see advanced programming in Chpt. 5.2.). In gearmotors with a built-in control unit, this connection is pre-wired as standard (fig. 2). For leaf opening direction, see advanced programming in Chpt 5.2.

4.7. Connector J3 - Encoder rapid connection (fig.2)

This input is designed for rapid connection of the Encoder (optional). To fit the encoder on the motor, refer to the relevant instructions. The presence of the encoder is signalled - when the gearmotor is running - by the flashing of the "Encoder" LED on the board. When the encoder is used, the control unit knows the exact position of the gate while it is moving. The encoder controls the adjustments of some of the control unit's functions in a different way (partial opening or deceleration - see advanced programming in Chpt 5.2) and as an anti-crushing device. If the gate strikes an obstacle during opening or closing, the encoder immediately reverses the gate leaf for 2 seconds. If the encoder operates again during the 2-seconds reversing time, it STOPS movement without commanding any reversing.

## 5. PROGRAMMING

To program operation of the automated system, you have to access the "PROGRAMMING" mode.

Programming is split into two parts: BASIC and ADVANCED.

### 5.1. BASIC PROGRAMMING

To access BASIC PROGRAMMING, press key **F**:

- if you press it (and hold it down), the display shows the name of the first function.
- if you release the key, the display shows the value of the function that can be modified with keys + and -.
- if you press **F** again (and hold it down), the display shows the name of the next function, etc.
- when you reach the last function, press **F** to exit the program, and the display resumes showing the gate status.

The following table shows the sequence of functions accessible in BASIC PROGRAMMING:

BASIC PROGRAMMING (F)		
Display	Function	Default
LO	<b>FUNCTION LOGICS (see tab. 3/a - h):</b> A = Automatic AP = "Stepped" automatic S = "Safety" Automatic E = Semi-automatic EP = "Stepped" Semi-automatic C = Dead-man b = "B" Semi-automatic bC = Mixed Log. (b opening / C closing)	EP
PA	<b>PAUSE TIME:</b> This has effect only if the automatic logic was selected. Adjustable from 0 to 59 sec. in one-second steps. Subsequently, display changes to minutes and tens of seconds (separated by a point) and time is adjusted in 10-second steps, up to the maximum value of 41 minutes. E.g. if the display shows 2.5, pause time is 2 min. and 50 sec.	2.0
FO	<b>FORCE:</b> Adjusts Motor thrust. 01 = minimum force 50 = maximum force	50
dl	<b>OPENING DIRECTION:</b> Indicates the gate opening movement and makes it possible not to change the motor and limit-switch connections on the terminal board. -3 = Right-hand opening movement E- = Left-hand opening movement	-3
St	<b>GATE STATUS:</b> Exit from programming and return to gate status viewing. 00 = Closed 01 = Now opening 02 = Stopped 03 = Open 04 = Pause 05 = "FAIL SAFE" tripped (chpt. 5.2) 06 = Now closing 07 = Now reversing 08 = Photocells tripped	



### 5.2. ADVANCED PROGRAMMING

To access ADVANCED PROGRAMMING, press key **F** and, as you hold it down, press key +:

- if you release key +, the display indicates the name of the first function.
- if you release key F too, the display shows the value of the function that can be modified with keys + and -.
- if you press key **F** (and hold it down), the display shows the name of the next function, and if you release it, the value that can be modified with keys + and - is shown.
- when you reach the last function, press **F** to exit the program, and the display resumes showing the gate status.

The following table shows the sequence of functions accessible in ADVANCED PROGRAMMING:

ADVANCED PROGRAMMING (F) + (+)		
Display	Function	Default
b0	<b>MAXIMUM TORQUE AT INITIAL THRUST:</b> The motor operate at maximum torque (ignoring the torque setting) at start of movement. Useful for heavy leaves. y = Active no = Disabled	y

ADVANCED PROGRAMMING (F) + (+)		
Display	Function	Default
br	<b>FINAL BRAKING:</b> When the gate engages the opening or closing limit-switch, a braking stroke can be selected to ensure the leaf is stopped immediately. If decelerations are selected, braking starts when they finish. At 00 value, braking is disabled. Time can be adjusted from 01 to 20 sec. in 0.1-second steps. E.g. if the display indicates 10, braking time is 1 second. 00 = Braking disabled from 01 to 20 = Timed braking	05
FS	<b>FAIL SAFE:</b> If this function is activated, it enables a function test of the photocells before any gate movement. If the test fails (photocells not serviceable signalled by value 05 on the display), the gate does not start moving. y = Active no = Disabled	no
PF	<b>PRE-FLASHING (5 s):</b> Activates the flashing lamp for 5 seconds before start of movement. no = Disabled oP = Only before opening CL = Only before closing 0C = Before every movement	no
SP	<b>INDICATOR-LIGHT:</b> If 00 is selected, the output functions as a standard indicator-light (lighted at opening and pause, flashing at closing, and off when gate closed). <b>Courtesy light:</b> Different figures correspond to timed activation of the output, which can be used (by a relay) to power a courtesy lamp. Time can be adjusted from 0 to 59 sec. in 1-second steps, and from 1.0 to 41 min. in 10-second steps. <b>Electric lock command and 'traffic lights' functions:</b> If you press key ⊖ from the 00 setting, the command for the E1 closing electric lock is activated; If you press ⊖ again, the command for the E2 closing and opening electric lock is set; if you press the ⊖ key again, you can set the 'traffic lights' functions E3 and E4. 00 = Standard indicator-light from 01 to 41 = Timed output. E1 = electric lock command before opening movement E2 = electric lock command before opening and closing movements E3 = 'traffic lights' function: the output is active in "open" and "open on pause" status and is disabled 3 seconds before the closing manoeuvre starts.  there is 3 seconds of pre-flashing before the closing manoeuvre. E4 = 'traffic lights' function: the output is active only in "closed" status.  Do not exceed the output's maximum load (24Vdc-3W). If necessary, use a relay and a power supply source outside the equipment.	00
Ph	<b>CLOSING PHOTOCELLS LOGIC:</b> Select the tripping mode of the closing photocells. They operate for the closing movement only: they stop movement and reverse it when they are released, or they reverse it immediately. y = Reverse on release no = Reverse immediately when opening	no
oP	<b>OPENING PHOTOCELLS LOGIC:</b> Select the tripping mode of the opening photocells. They operate for the opening movement only: they stop the movement and restart it when they are released, or they reverse it immediately. y = Reverse immediately when closing no = Restart movement on release	no

ADVANCED PROGRAMMING (F) + (+)		
Display	Function	Default
EC	<p><b>ENCODER:</b> If the encoder is used, you may select its presence. If the encoder is present and enabled, "decelerations" and "partial opening" are controlled by the encoder (see relevant paragraphs). The encoder operates as an anti-crushing device: If the gate strikes an obstacle during opening or closing, the encoder immediately reverses gate leaf movement for 2 seconds. If the encoder operates again during the 2-seconds reversing time, it stops movement (STOP) without commanding any reversing. If no sensor is supplied, the parameter must be set on 00. If there is the encoder, adjust the sensitivity of the anti-crushing system, by varying the parameter between 01 (maximum sensitivity) and 99 (minimum sensitivity). From 01 to 99 = Encoder active and sensitivity adjustment 00 = Encoder disabled</p>	00
rP	<p><b>Pre-limit switch DECELERATION:</b> You can select gate deceleration before the opening and closing limit-switches have been tripped. Time can be adjusted from 00 to 99. If an encoder is used, the adjustment is not determined by time but by motor revs, thus obtaining greater deceleration precision. 00 = Deceleration disabled from 01 to 99 = Deceleration enabled</p>	00
rA	<p><b>Post-limit switch DECELERATIONS:</b> You can select gate deceleration after the opening and closing limit-switches have been tripped. Time can be adjusted from 00 to 20 sec. in 0.04-second steps. If an encoder (optional) is used, the adjustment is not determined by time but by motor revs, thus obtaining greater deceleration precision. 00 = Deceleration disabled from 01 to 20 = Deceleration enabled</p>	05
PO	<p><b>PARTIAL OPENING:</b> You can adjust the width of leaf partial opening. Time can be adjusted from 01 to 20 sec. in 0.1-second steps. If an encoder (optional) is used, the adjustment is not determined by time but by motor revs, thus obtaining greater precision of partial opening. E.g. for a gate with a sliding speed of 10 m /min, value 10 corresponds to about 1.7 metres of opening. E.g. for a gate with a sliding speed of 12 m /min, value 10 corresponds to about 2 metres of opening.</p>	05
t	<p><b>WORK TIME:</b> We advise you to set a value of 5 to 10 seconds over the time taken by the gate to travel from the closing limit-switch to the opening limit-switch and vice versa. This will protect the motor against any overheating if a limit-switch fails. Adjustable from 0 to 59 sec. sec. in one-second steps. Subsequently, viewing changes to minutes and tens of seconds (separated by a point) and time is adjusted in 10 second steps, up to a maximum value of 41 minutes. E.g. if the display shows 25, work time is 2 min. and 50 sec.  the set value does not exactly match the motor's maximum operating time, because the latter is modified according to the performed deceleration spaces.</p>	41
AS	<p><b>ASSISTANCE REQUEST (combined with next function):</b> If activated, at the end of countdown (settable with the next function i.e. "Cycle programming") it effects 2 sec. of pre-flashing (in addition to the value already set with the PF function) at every Open pulse (job request). Can be useful for setting scheduled maintenance jobs. y = Active no = Disabled</p>	no

ADVANCED PROGRAMMING (F) + (+)		
Display	Function	Default
nc	<p><b>CYCLE PROGRAMMING:</b> For setting countdown of system operation cycles. Settable (in thousands) from 00 to 99 thousand cycles. The displayed value is updated as cycles proceed. This function can be used to check use of the board or to exploit the "Assistance request".</p>	00
St	<p><b>GATE STATUS:</b> Exit from programming and return to gate status viewing (see Chpt 5.1.).</p>	

**Note 1:** to reset the programming default settings, check if the edge input is opened (SAFE LED OFF), and simultaneously press keys +, - and F, holding them down for 5 seconds.

**Note 2:** modification of programming parameters comes into effect immediately, whereas definitive memory storage occurs only when you exit programming and return to gate status viewing. If the equipment is powered down before return to status viewing, all modifications will be lost.

## 6. START-UP

### 6.1. INPUTS CHECK

The table below shows the status of the LEDs in relation to the status of the inputs.

Note the following: **Led lighted** = closed contact  
**Led off** = open contact

Check the status of the LEDs as per Table.  
Operation of the signalling status LEDs

dI = -3 = Right-hand opening movement

LEDS	LIGHTED	OFF
FCA	Limit-switch free	Limit-switch engaged
FCC	Limit-switch free	Limit-switch engaged
OPEN B	Command activated	Command inactive
OPEN A	Command activated	Command inactive
FSW OP	Safety devices disengaged	Safety devices engaged
FSW CL	Safety devices disengaged	Safety devices engaged
STOP	Command inactive	Command activated
EDGE	Safety devices disengaged	Safety devices engaged

 The status of the LEDs while the gate is closed at rest are shown in bold.

dI = E- = Left-hand opening movement

LEDS	LIGHTED	OFF
FCA	Limit-switch free	Limit-switch engaged
FCC	Limit-switch free	Limit-switch engaged
OPEN B	Command activated	Command inactive
OPEN A	Command activated	Command inactive
FSW OP	Safety devices disengaged	Safety devices engaged
FSW CL	Safety devices disengaged	Safety devices engaged
STOP	Command inactive	Command activated
EDGE	Safety devices disengaged	Safety devices engaged

 The status of the LEDs while the gate is closed at rest are shown in bold.

## 7. AUTOMATED SYSTEM TEST

When you have finished programming, check if the system is operating correctly.

Most important of all, check if the force is adequately adjusted and if the safety devices are operating correctly.

Tab. 3/a							
LOGIC "A"	PULSES						
GATE STATUS	OPEN-A	OPEN-B	STOP	OPENING SAFETY DEVICES	CLOSING SAFETY DEVICES	OP/CLOS. SAFETY DEVICE	EDGE SAFETY DEVICE
<b>CLOSED</b>	Opens the leaf and closes it after pause time <sup>Ⓞ</sup>	Opens leaf for the partial opening time and closes after pause time <sup>Ⓞ</sup>	No effect (OPEN disabled)		No effect	No effect (OPEN disabled)	
<b>OPEN on PAUSE</b>	Reloads pause time <sup>Ⓞ</sup>		Stops operation	No effect	Reloads pause time <sup>Ⓞ</sup> (OPEN disabled)		No effect (OPEN disabled)
<b>ON CLOSING</b>	Re-opens the leaf immediately <sup>Ⓞ</sup>			No effect (saves OPEN)	see paragraph 5.2.	Stops and, on release, reverses on opening	Reverses on opening for 2" <sup>Ⓞ</sup>
<b>ON OPENING</b>	No effect <sup>Ⓞ</sup>			see paragraph 5.2.	No effect	Stops and, on release, continues opening	Reverses on closing for 2" <sup>Ⓞ</sup>
<b>STOPPED</b>	Closes the leaf		No effect (OPEN disabled)	No effect		No effect (OPEN disabled)	

Tab. 3/b							
LOGIC "AP"	PULSES						
GATE STATUS	OPEN-A	OPEN-B	STOP	OPENING SAFETY DEVICES	CLOSING SAFETY DEVICES	OP/CLOS. SAFETY DEVICE	EDGE SAFETY DEVICE
<b>CLOSED</b>	Opens the leaf and closes it after pause time <sup>Ⓞ</sup>	Opens leaf for the partial opening time and closes after pause time <sup>Ⓞ</sup>	No effect (OPEN disabled)		No effect	No effect (OPEN disabled)	
<b>OPEN on PAUSE</b>	Re-closes the leaf immediately		Stops operation	No effect	Reloads pause time <sup>Ⓞ</sup> (OPEN disabled)		No effect (OPEN disabled)
<b>ON CLOSING</b>	Re-opens the leaf immediately <sup>Ⓞ</sup>			No effect (saves OPEN)	see paragraph 5.2.	Stops and, on release, reverses on opening	Reverses on opening for 2" <sup>Ⓞ</sup>
<b>ON OPENING</b>	Stops operation			see paragraph 5.2.	No effect	Stops and, on release, continues opening	Reverses on closing for 2" <sup>Ⓞ</sup>
<b>STOPPED</b>	Closes the leaf		No effect (OPEN disabled)	No effect		No effect (OPEN disabled)	

Tab. 3/c							
LOGIC "S"	PULSES						
GATE STATUS	OPEN-A	OPEN-B	STOP	OPENING SAFETY DEVICES	CLOSING SAFETY DEVICES	OP/CLOS. SAFETY DEVICE	EDGE SAFETY DEVICE
<b>CLOSED</b>	Opens leaves and closes them after pause time	Opens leaf for the partial opening time and closes after pause time <sup>Ⓞ</sup>	No effect (OPEN disabled)		No effect	No effect (OPEN disabled)	
<b>OPEN on PAUSE</b>	Re-closes the leaf immediately		Stops operation	No effect	Closes after 5" (OPEN disabled)		No effect (OPEN disabled)
<b>ON CLOSING</b>	Re-opens the leaf immediately			No effect (saves OPEN)	see paragraph 5.2.	Stops and, on release, reverses on opening	Reverses on opening for 2" <sup>Ⓞ</sup>
<b>ON OPENING</b>	Re-closes the leaf immediately			see paragraph 5.2.	No effect	Stops and, on release, continues opening	Reverses on closing for 2" <sup>Ⓞ</sup>
<b>STOPPED</b>	Closes the leaf		No effect (OPEN disabled)	No effect		No effect (OPEN disabled)	

**Tab. 3/d**

LOGIC "E"	PULSES						
GATE STATUS	OPEN-A	OPEN-B	STOP	OPENING SAFETY DEVICES	CLOSING SAFETY DEVICES	OP/CLOS. SAFETY DEVICE	EDGE SAFETY DEVICE
<b>CLOSED</b>	Opens the leaf	Opens the leaf for partial opening time	No effect (OPEN disabled)		No effect	No effect (OPEN disabled)	
<b>OPEN</b>	Re-closes the leaf immediately		Stops operation	No effect	No effect (OPEN disabled)		
<b>ON CLOSING</b>	Re-opens the leaf immediately			No effect (saves OPEN)	see paragraph 5.2.	Stops and, on release, reverses on opening	Reverses on opening for 2" ®
<b>ON OPENING</b>	Stops operation			see paragraph 5.2.	No effect	Stops and, on release, continues opening	Reverses on closing for 2" ®
<b>STOPPED</b>	Closes the leaf (with the Closing safety devices engaged, it opens at the 2 <sup>nd</sup> pulse)		No effect (OPEN disabled)	No effect		No effect (OPEN disabled)	

**Tab. 3/e**

LOGIC ""EP""	PULSES						
GATE STATUS	OPEN-A	OPEN-B	STOP	OPENING SAFETY DEVICES	CLOSING SAFETY DEVICES	OP/CLOS. SAFETY DEVICE	EDGE SAFETY DEVICE
<b>CLOSED</b>	Opens the leaf	Opens the leaf for partial opening time	No effect (OPEN disabled)		No effect	No effect (OPEN disabled)	
<b>OPEN</b>	Re-closes the leaf immediately		Stops operation	No effect	No effect (OPEN disabled)		
<b>ON CLOSING</b>	Stops operation			No effect (saves OPEN)	see paragraph 5.2.	Stops and, on release, reverses on opening	Reverses on opening for 2" ®
<b>ON OPENING</b>				see paragraph 5.2.	No effect	Stops and, on release, continues opening	Reverses on closing for 2" ®
<b>STOPPED</b>	Restarts movement in reverse direction (always closes after a Stop)		No effect (OPEN disabled)	No effect (if it must open, it disables OPEN)	No effect (if it must close, it disables OPEN)	No effect (OPEN disabled)	

**Tab. 3/f**

LOGIC "C"	CONTROLS ALWAYS HELD DOWN		PULSES				
GATE STATUS	OPEN-A (opening)	OPEN-B (closing)	STOP	OPENING SAFETY DEVICES	CLOSING SAFETY DEVICES	OP/CLOS. SAFETY DEVICE	EDGE SAFETY DEVICE
<b>CLOSED</b>	Opens the leaf	No effect	No effect (OPEN-A disabled)		No effect (OPEN-B disabled)	No effect (OPEN-A disabled)	No effect (OPEN-A/B disabled)
<b>OPEN</b>	No effect	Closes the leaf	No effect (OPEN-B disabled)	No effect (OPEN-A disabled)		No effect (OPEN-B disabled)	
<b>ON CLOSING</b>	Stops operation	Stops operation	Stops operation	No effect	Stops operation (OPEN-B disabled)	Stops operation (OPEN-A/B disabled)	Reverses on opening for 2" ®
<b>ON OPENING</b>				Stops operation	Stops operation (OPEN-A disabled)		No effect

Tab. 3/g							
LOGIC "B"	PULSES						
GATE STATUS	OPEN-A (opening)	OPEN-B (closing)	STOP	OPENING SAFETY DEVICES	CLOSING SAFETY DEVICES	OP/CLOS. SAFETY DEVICE	EDGE SAFETY DEVICE
<b>CLOSED</b>	Opens the leaf	No effect	No effect (OPEN-A disabled)		No effect (OPEN-B disabled)	No effect (OPEN-A disabled)	No effect (OPEN-A/B disabled)
<b>OPEN</b>	No effect	Closes the leaf	No effect (OPEN-B disabled)	No effect (OPEN-A disabled)		No effect (OPEN-B disabled)	
<b>ON CLOSING</b>	Reverses on opening	No effect	Stops operation	No effect	Stops operation (OPEN-B disabled)	Stops operation (OPEN-A/B disabled)	Reverses on opening for 2" <sup>®</sup>
<b>ON OPENING</b>	No effect			Stops operation (OPEN-A disabled)	No effect		Reverses on closing for 2" <sup>®</sup>
<b>STOPPED</b>	Opens the leaf	Closes the leaf	No effect (OPEN-A/B disabled)	No effect (OPEN-A disabled)	No effect (OPEN disabled)	No effect (OPEN-A/B disabled)	

Tab. 3/h							
LOGIC "BC"	OPENING PULSES / CLOSING COMMANDS ALWAYS PRESSED		PULSES				
GATE STATUS	OPEN-A (opening)	OPEN-B (closing)	STOP	OPENING SAFETY DEVICES	CLOSING SAFETY DEVICES	OP/CLOS. SAFETY DEVICE	EDGE SAFETY DEVICE
<b>CLOSED</b>	Opens the leaf	No effect	No effect (OPEN-A disabled)		No effect	No effect (OPEN-A disabled)	
<b>OPEN</b>	No effect	Closes the leaf	No effect (OPEN-B disabled)	No effect	No effect (OPEN-B disabled)		No effect (OPEN-A/B disabled)
<b>ON CLOSING</b>	Reverses to open	No effect	Stops operation	No effect (saves OPEN A)	Stops operation (OPEN-B disabled)	Stops operation (OPEN-A/B disabled)	Reverses to open for 2" <sup>®</sup>
<b>ON OPENING</b>	No effect			Stops operation (OPEN-A disabled)	No effect		Reverses to close for 2" <sup>®</sup>
<b>STOPPED</b>	Opens the leaf	Closes the leaf	No effect (OPEN-A/B disabled)	No effect (OPEN-A disabled)	No effect (OPEN-B disabled)	No effect (OPEN-A/B disabled)	

- <sup>®</sup> If maintained, it prolongs the pause until disabled by the command (timer function)
- <sup>®</sup> If a new pulse occurs within 2 seconds after reversing, it immediately stops operation.

 Effects on other active pulse inputs in brackets.

Le descrizioni e le illustrazioni del presente manuale non sono impegnative. FAAC si riserva il diritto, lasciando inalterate le caratteristiche essenziali dell'apparecchiatura, di apportare in qualunque momento e senza impegnarsi ad aggiornare la presente pubblicazione, le modifiche che essa ritiene convenienti per miglioramenti tecnici o per qualsiasi altra esigenza di carattere costruttivo o commerciale.

The descriptions and illustrations contained in the present manual are not binding. FAAC reserves the right, while leaving the main features of the equipments unaltered, to undertake any modifications to hold necessary for either technical or commercial reasons, at any time and without revising the present publication.

Les descriptions et les illustrations du présent manuel sont fournies à titre indicatif. FAAC se réserve le droit d'apporter à tout moment les modifications qu'elle jugera utiles sur ce produit tout en conservant les caractéristiques essentielles, sans devoir pour autant mettre à jour cette publication.

Las descripciones y las ilustraciones de este manual no comportan compromiso alguno. FAAC se reserva el derecho, dejando inmutadas las características esenciales de los aparatos, de aportar, en cualquier momento y sin comprometerse a poner al día la presente publicación, todas las modificaciones que considere oportunas para el perfeccionamiento técnico o para cualquier otro tipo de exigencia de carácter constructivo o comercial.

Die Beschreibungen und Abbildungen in vorliegendem Handbuch sind unverbindlich. FAAC behält sich das Recht vor, ohne die wesentlichen Eigenschaften dieses Gerätes zu verändern und ohne Verbindlichkeiten in Bezug auf die Neufassung der vorliegenden Anleitungen, technisch bzw. konstruktiv / kommerziell bedingte Verbesserungen vorzunehmen.

De beschrijvingen in deze handleiding zijn niet bindend. FAAC behoudt zich het recht voor op elk willekeurig moment de veranderingen aan te brengen die het bedrijf nuttig acht met het oog op technische verbeteringen of alle mogelijke andere productie- of commerciële eisen, waarbij de fundamentele eigenschappen van het apparaat gehandhaafd blijven, zonder zich daardoor te verplichten deze publicatie bij te werken.



# FAAC

**FAAC S.p.A.**  
Via Benini, 1  
40069 Zola Predosa (BO) - ITALIA  
Tel. 0039.051.61724 - Fax. 0039.051.758518  
[www.faac.it](http://www.faac.it)  
[www.faacgroup.com](http://www.faacgroup.com)



732697\_Rev.A