

ECA Electronic Engineering Pty. LTD.

Australia

www.gatesonsolar.com

Tel: 03-95720 535

Fax: 95 720 536

Control Panel for Swing Gates

Model: CP-12 SOLAR



Model: CP-12 SOLAR INSTALLATION MANUAL

INDEX

Page

1- INTRODUCTION	3
1.1 Electrical and mechanical specification	
1.2 General Features	
2- INSTALLATION AND SETUP	
2.1.1 Installation of actuator type operators	4
2.1.2 Self-learning mode for actuators	5
2.1.3 Installation and self-learning setup for folding arm operators	6
2.2 Setting opening time delay between the gates	5
2.3 Remote controls – Teaching & Deleting	7
2.4 Control panel’s wiring and connections	8
2.5 Control panel’s wiring Diagram	9
2.6 Selecting features by the DIP switches	10
2.7 Setting Automatic closure time delay	10
2.8 Sensitivity adjustment	
2.8.1 Over-current sensitivity adjustment	10
2.8.2 Over-current sensitivity selection	11
2.8.3 Anti-crash sensor during closure	11
2.9 External time clock	11
2.10 Automatic mode	11
2.11 Pedestrian mode	11
2.12 Photo Beam Sensor connection	11
3- Solar Panel INSTALLATION	11
Warranty	13

Model: CP-12 SOLAR INSTALLATION MANUAL

1-INTRODUCTION

1.1 Electrical and Mechanical Specifications

Power supply:	12V – 18V DC / 10Watt Solar Panel
Rechargeable Battery:	12VDC / 8.4AH (2 x 4.2 AH)
Standby Current Consumption:	Amp
Power supply of the motors	12VDC/10A, 120W (MAX)
Power output to the Photo Sensor:	12VDC, 1.5 Amp (MAX)
Power output to the electric lock:	12VDC, 2 Amp (MAX)
Remote control:	4 – Channel Top Security Rolling Code
Radio frequency:	433.92MHz
Receiver:	Learning type ("Service Free" learning)
Power supply of the accessories:	12VDC, 1 Amp. Max
Over-current protection:	5Amp Automatic Poly Fuse.
Working temperature range:	-20C°~55C°
Automatic closure Timers:	Programmable.
Operation Timers:	Self Learning - Automatic setup
Dimensions and weight:	300 x 245 x 90 mm, 5kgs

1.2 General Features

- **Single / Dual swing gate operation Selector.**
- **Suitable for 12V / DC Actuators or Folding Arms (with limit switches) operators.**
- **Two types of current sensors to choose from; for light or heavy gates.**
- **Adjustable overload current sensor for safe operation.**
- **Built-in heavy duty rechargeable batteries for long lasting operation.**
- **Top security rolling code remote controls.**
- **High range operation remote controls with internal Ant. - up to 100m' in open air.**
- **Learning type radio receiver with wireless learning of remote controls.**
- **"Service-Free" learning of new remote controls – without the need of a technician.**
- **Programmable Timer for Auto-Close operation.**
- **Self-learning System. The control panel sets up all its timers automatically.**
- **Slow Down speed for smooth operation and quiet closure and opening.**
- **Safety Sensor connections with zero current consumption on standby – optional.**
- **Single or Double gates selector.**
- **Photo sensor output / input with Zero standby current consumption.**

Model: CP-12 SOLAR INSTALLATION MANUAL

INSTALLATION & SETUP for Actuator motors

2.1.1 Installation of Actuators

- Step1:** First install the operator's bracket to the posts or pillar about 15 – 18cm away from the center of the gate's hinges. See the diagram on page 5 and the owner's manual for the exact measurements of welding points of the brackets to post.
- Step2:** Use the battery from the control panel and connect the two wires of the motor to bring the actuator to full extension, and then change the polarity to the battery to bring back in, the actuator about 5mm.
- Step3:** Bring the gate to fully close position and install the “ T ” bracket to the gate when the actuator is in this position (almost fully extended).
- Step4:** Use the battery to test the gate for opening and closing by connecting the motor's wires to the battery. Change the polarity of the motor's wires to the battery to change direction (open and close).
- Step5:** Install stoppers on the ground for end of closure and end of opening for each of the gates.
- Step 7:** If the operators are used as **pull to open** then:
1. Connect the motor's wires that should open first (Master) to the terminals marked as **MM1** in the control panel, while the **Black wire** of the motor should be connected to the left and the **white (or Red) wire to the right** terminal of MM1.
(Note: For single gate operation connect the motor to MM1 terminals.)
 2. Connect the second motor's wires that should open second (slave) to the terminals of SM2 in the control panel, while the **Black wire** of the motor to the left and the **white (or Red) wire** to the **right** terminal.
- For push to open swap between the black and white wires of each motor.**
- Step 8:** Use the over-ride keys to put the operators into manual and bring the gates to close position and then put the gates back in gear to be engaged.
- Step 9:** Connect the two batteries in the control box to their wires, **Red to Positive** and **Black to Negative** poles of the batteries.
- Step 10:** Connect the solar panel's wires, **Negative** to the **Black** wire and the **Positive** to the **Red** wire in the control panel's solar panel input terminals.
- Step 10:** See instructions for self-learning and automatic setup for actuators.

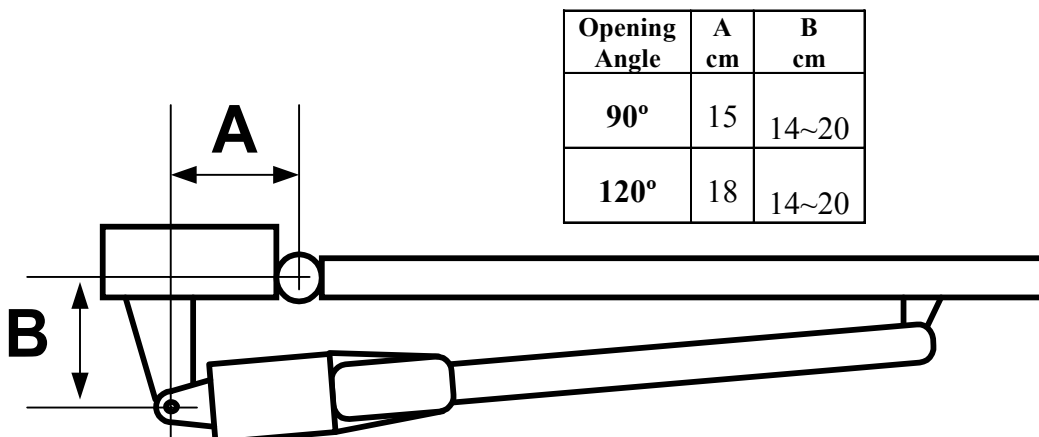

Model: CP-12 SOLAR INSTALLATION MANUAL

2.1.2 Self-Learning operation system for Actuators

- Step 1:** Make sure that the gates are closed and the right mode for dual or single gate operation is chosen by dipswitch # 2
- Step 2:** Make sure that the dip-switches #3 and #4 are in **OFF position**.
(not in use for Actuator type operation).
- Step 3:** Make sure the motor's wires that should open first (Master) are connected to terminals **MM1** and the second motor's wires that should open second (slave) are connected to the terminals **SM2** in the control panel.
- Step 4:** Press and release the program button in the control panel. The program LED will start to flash fast indicating that you have now **entered the Program Mode**.
- Step 5:** Press and release button (I) on the remote control and the self-learning operation will start step by step as follows:

For Dual Gates:

The Master Gate will open and close twice and stay open. Then the Slave Gate will open and close twice and then open. Now the program LED light will start flashing slowly to indicate closure of the gates according to the learning set up.

For Single Gate:

The Gate (MM1) will open and close twice with the program LED light flashing fast to indicate learning is in possess, after which the gate will close with the program LED flashing slowly to indicate closure of the gate according to the learning set up.

Opening time delay between the gates :

The control panel sets the opening time delay between the gates and the fast and slow operation time of the motors automatically. However, you can program and cancel the opening time delay so that both the gates will open and close simultaneously.

See "**Opening Time Delay**" set up below.

End of system set up. Now the system is ready for operation.

2.2 Setting Opening Time Delay between the gates

The control panel sets two seconds *opening time delay* between the Master and the Slave gate automatically. However, you can cancel this "opening time-delay" so that both the gates will open and close simultaneously. For selecting **with or without "opening time delay"** do as follows: Press and hold "PROGRAM" button in the control panel until the Program LED turns on (a "click" sound will be heard). Press and release Button (II) on the remote control once and the program LED will flash twice (and a double "click" sound will be heard) to confirm cancellation of the time delay – it means that both gates will open and close always simultaneously. To change back the setting to be with the two seconds time delay; repeat the above procedure and this time three "click" sound will be heard to confirm and indicate this selection.

Model: CP-12 SOLAR INSTALLATION MANUAL

2.1.3 Self-Learning operation system for Folding Arm (F.A.) operators

- Step 1:** Install the operators to the gate according to the installation manual.
- Step 2:** Insert the Hex override key supplied in the kit, to put the gates on manual by rotating it *Clockwise* until it stops. The gates will disengage and will open and close freely.
- Step 3:** Close the gates and use a 3mm Hex key to adjust the top cam-shaft of each unit to hit the top limit switch at the end of closure. Open the gates and adjust the bottom cam shaft of each unit to hit the bottom limit switch at the end of opening. It is recommended to do the fine adjustments later by tapping on the cam-shaft with a hammer and a chisel.
- Step 4:** Connect the wires of the motor that should open first to terminal MM1 in the control panel as follows: Connect the **Black wire of the motor** to the **left output in terminal MM1** and the **Red wire of the motor** to the **Right output of the terminal MM1**. Connect the wires of the second motor to terminal SM2 accordingly. Black to the Left and Red to the Right in the terminal SM2.
- Step 5:** Make sure that the position of the dip-switches in the control panel are as follows:
See that **dip-switch #4 is in ON position (for set up only)**
See that **dip-switch #3 is in ON position** (for F.A. type operation)
See that the right mode for Dual or Single gate operation is chosen by **dipswitch # 2**
- Step 6:** Connect the two batteries in the control panel by connecting the RED wires to the Positive (Red) poles of the batteries and the BLACK wires to the Negative (black) poles of the batteries.
- Step 7:** Press and release the PROGRAM button in the control panel. The Program LED light will start to flash fast indicating that you have now **entered the Program Mode**.
- Step 8:** Press and release button (I) on the remote control and the **self-learning operation** will be executed. **Automatic** set up will proceed as follows:
For Dual Gates: The Master Gate (MM1) will open and close and open. Then the Slave Gate (SM2) will open and close and open. Now the program LED light will start flashing slowly to indicate closure of the gates according to the setup.
Opening Time Delay: Please note that the control panel sets all the timers of the system automatically. The opening time delay between the Master and the Slave gate (in opening and closing) and the fast and slow operation time of the each gate is calculated automatically during the setup. However, you can cancel the opening time delay so that **both the gates will open and close simultaneously** if the gates can be individually operated. See “**Opening Time Delay**” set up on page 5.
For Single Swing Gate: The Gate will open and close twice with the program LED light flashing fast to indicate learning is in progress, after which the gate will close with the program LED light flashing slowly to indicate closure of the gate according to the learning setup.
- Step 9:** **Turn the dip-switch #4 to OFF position.**
- Step 10:** Install the solar panel according to the instructions (see page 11) and connect its wires to the solar panel input in the control panel. Make sure that the solar panel is covered with a dark cloth and that its wires are not touching each other during installation and connection.
- Step 11:** Adjust the current sensor by the variable resistor VR1.

End of system setup. Now the system is ready for operation.

Model: CP-12 SOLAR INSTALLATION MANUAL

2.3 Remote Control Teaching & Deleting from the Memory

The control panel's radio receiver can learn up to 160 remote controls into its memory. It can learn any of the buttons (I), (II) or (III) of the remote control (Model TR-4RS) for operating the gates. Button (IV) is reserved for operating Motor-SM2 **only** as a pedestrian gate if required. There are two ways of teaching new remote controls:

2.3.1 **Teaching remote controls from the control panel**

Press and release the "REMOTE" push button in the control panel and the program LED light will start to flash indicating that the receiver is ready to learn the new remote control's button. Choose and press on one of the buttons (I), (II), (III) or (IV) in the remote control for one second and the LED light will stop flashing to indicate that the remote control's button has been learned into the receiver's memory.



2.3.2 "Service – Free" Teaching Method

This method allows the end user to teach new remote controls into the receiver's memory without the need of neither a technician nor opening the control panel's box. Use an operational remote control of the unit, (a remote control that is operating the unit only) to teach a new remote control into the receiver's memory as follows:

Use the remote control that already operates the system and stand about 1m' from the control panel box. Press and hold both the buttons (II) and (I) simultaneously for 5 second. After releasing the buttons of the original remote control the light relay in the control panel will start to "CLICK" indicating that the receiver is ready to learn the new remote control's button. **Choose**, press and release for one second on one of the buttons (I), (II), (III) or (IV) of the **NEW remote control**. The "CLICKING" sound from the control panel will stop to indicate that the remote control's button has been learned into the receiver's memory.

2.3.3 **Deleting all remote controls from the receiver's memory**

Press and HOLD the "REMOTE" push button in the control panel till the Program LED turns on (a "CLICK" sound will be heard). Now, you have 5 seconds to press and release the "REMOTE" push button once again, in order to clear the receiver's memory. If the "REMOTE" push button has not been pressed within the 5 seconds, the control panel will exit this mode and turn off the program LED light indicating cancellation.

If you press the "REMOTE" push button within the 5 seconds the program LED light will start to flash indicating that "**Deleting all the remote controls from the memory is in Process**". All the remote controls will be deleted as soon as the program LED will stop to flash. The system now is ready to learn new remote controls.

Model: CP-12 SOLAR INSTALLATION MANUAL

2.4 Control Panel's Wiring

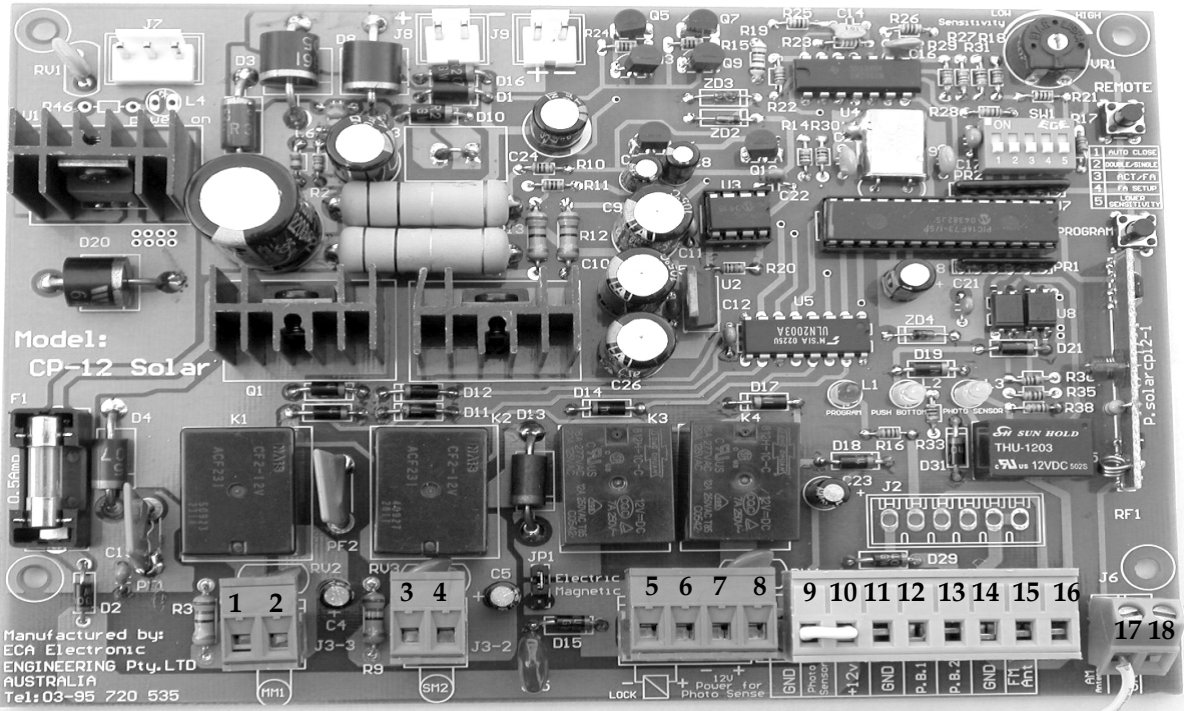

Number	Description
1 & 2	Terminals MM1 - Connect the Master motor (the motor that should open first) to this output. Connect the Black wire of the motor to terminal No. 1 and the RED wire of the motor to terminal No. 2 . For single gate operation connect the motor to this terminal output only.
3 & 4	Terminals SM2 - Connect the Slave Motor (the gate that opens second) to this output. Connect the Black wire of the motor to terminal No. 3 and the RED wire of the motor to Terminal No. 4
5 & 6	12V DC / 2A output for electric lock. Terminal No. 5 is Negative and Terminal No. 6 is positive
7 & 8	12V DC / 1A output for Photo Sensor. Terminal No. 7 is Negative and Terminal No. 8 is positive Note ! This terminal is active with 12V ONLY during the closing cycle of the gates.
9, 12, 15	GRD (-) Negative outputs.
10	Connect to the Normally Close contact of the photo sensor's relay. Jumper this terminal to Terminal #9 if photo sensor is not used, otherwise the systems wouldn't operate.
11	+12V DC output power. Do not use this output for high consumption circuitry. Max 5mA
12 & 13	Connect to Normally Open Push Button output to open and close both gates for manual operation.
14 & 15	Connect to Normally Open Push Button or to the intercom system's relay (must be voltage free contacts) output to operate the Slave Gate only in pedestrian mode. Only one gate (MM1) will open and close.
16	FM Antenna input for the plug-in receiver – optional.
17	AM Antenna input. Connect to External Aerial cable Model ANT-433 for extending operation range.
18	Ground shield of the Aerial cable should be connected to the GND terminal.

Model: CP-12 SOLAR INSTALLATION MANUAL

2.4.1 Control Panel's Wiring Diagram

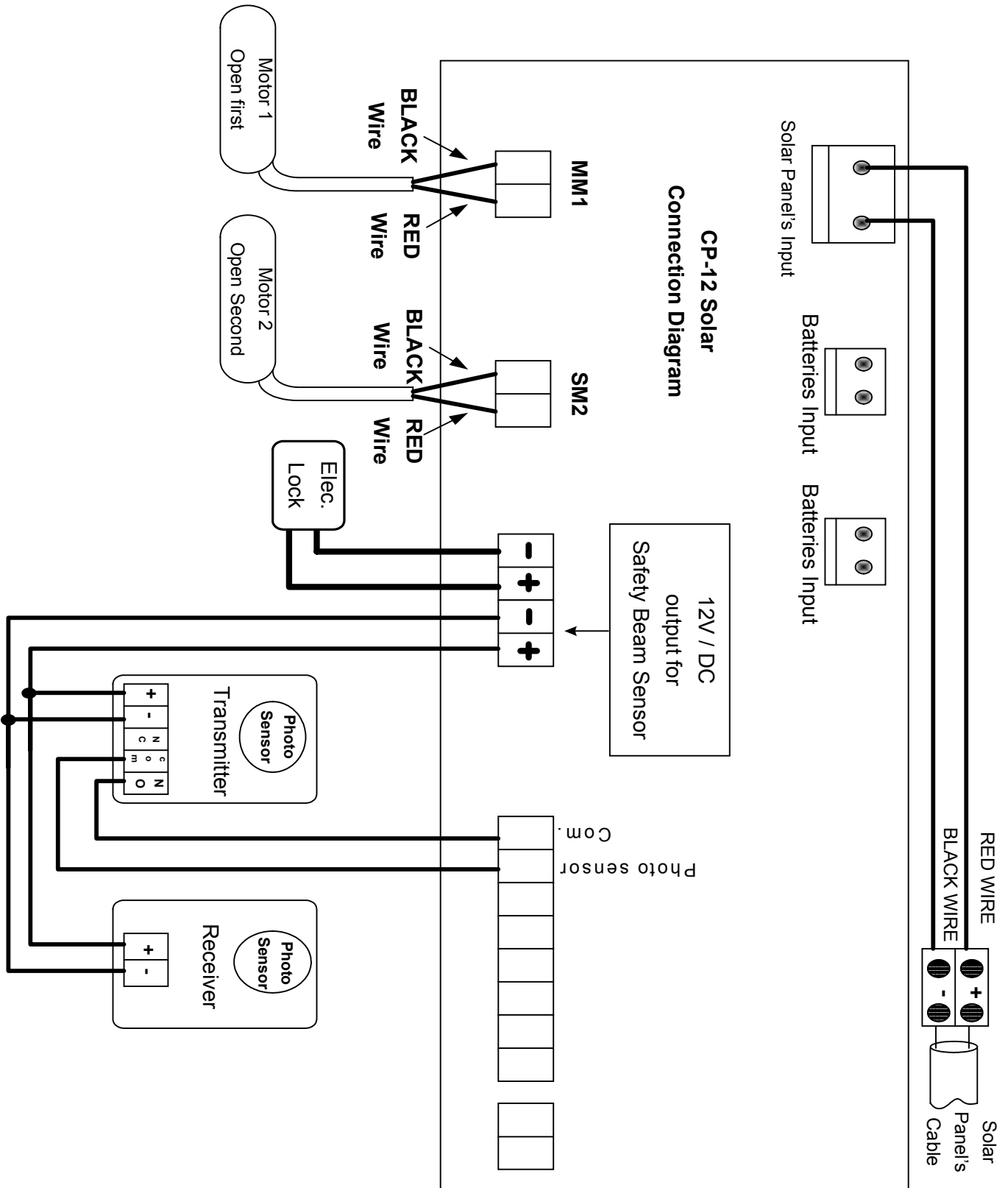

Model: CP-12 SOLAR INSTALLATION MANUAL

2.5 DIP switch selectors:

Auto Close:

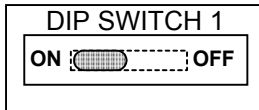

This dip-switch is for choosing the automatic closure function:

ON: = automatic closure function is ON.

OFF: = automatic closure function is OFF.

Single / Dual:

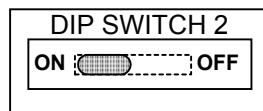

This dip-switch is for choosing the right program of single or dual gates operation:

ON: = Single gate.

OFF: = Dual gates.

Operator's type selector:

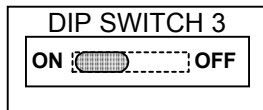

This dip-switch is for choosing the right operation program according to the type of operators used on the gates:

ON: F. A. = Folding Arm type of operators with limit switches.

OFF: ACT. = Actuators type operators without limit switches.

Setup Folding Arms:

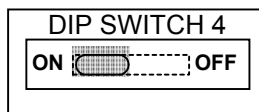

This dip-switch is in use in set up of timers for the **Folding Arm** units ONLY:

ON: = put this dipswitch ON before set up is done for FA mode only.

OFF: = put this dipswitch OFF at all time and when set up for FA mode is finished.

Lower Sensitivity:

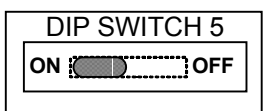

This dip-switch is in use in reduce the sensitivity of the over-current sensor:

ON: = Turn this dipswitch ON to reduce the over-current sensitivity by half.

OFF: = Normal over-current sensitivity.

2.6 Setting Automatic Closure Time Delay

For setting the **Auto Close Time Delay**, press and hold the **"PROGRAM"** push button in the control panel until the Program LED light turns on, (a "click" sound will be heard) and then release the button. Press and release button (I) on the remote control and the program LED will start to flash indicating that the auto close timer started to set itself. Wait the required interval of time you would like to set the timer (say 30 seconds) and then press and release button (I) on the remote control once again. The program LED will stop flashing indicating that the timer has been set. You can repeat the above procedure and change the setting as many times as you wish.

2.7.1 Over-Current Sensitivity Adjustment



The sensitivity of the Over-Current sensor can be adjusted from 1.5Amp to 3.5Amp (when dipswitch No. 5 is OFF) or from 3.5Amp. to 7Amp (when the dip- switch No. 5 is ON) by the variable resistor VR1 in the control panel. Use a small screwdriver for turning the trimmer **clockwise** to increases the sensitivity of detection or **anticlockwise** to reduce the sensitivity.

Model: CP-12 SOLAR INSTALLATION MANUAL

2.7.2 Over-Current Sensitivity Selection

In addition to manual adjustment of the Over-Current sensor, the control panel allows you to choose two levels Over-Current Sensitivity modes. The Current Sensitivity Sensor of the control panel has been set to **HIGH Mode** in the factory for light gates, however, you can change the setting of the sensitivity sensor to suit bigger and heavier gates by changing the setting to **LOW Mode**.

To change the Mode of the setting for the sensitivity sensor, do as follows:

1. Press and hold the Program button in the control panel till the Program LED light turns ON.
2. Press and release **button (IV)** on the remote control and the setting will change. The program LED light will flash twice to indicate that **LOW sensitivity Mode** has been selected and it will flash once for indicating **HIGH sensitivity Mode** selection.
3. You can repeat the above procedure to change the setting as many time as you wish.

2.7.3 Anti crash sensor during closure

During the fast travel time of the gates; if the motor's current is over the limit setting by (RV1), the gates will stop in opening phase and stop and reopen in closing phase.

2.8 External Time Clock and Timers

An external clock can be used and connected to the push button-1 input of the control panel to command the gates to open and close (in automatic mode only) at a specific time. Use the Normally Open (Voltage Free) contacts of an external Clock or Timer and connect them to terminals #12 and #13 in the control panel. Set the clock to close its contacts during the interval time that you wish the gates to open and stay open. The gate will close only after the Clock's contacts are open and after the preset time for automatic closure has finished.

2.9 Automatic Mode

At the end of automatic time delay, the gate will close automatically but if a new command (push button, photo sensor over-current, remote control) is acquired before the end of travel, the gate will open once again and wait the time delay before it closes again.

2.10 Pedestrian Mode: Systems can be operated in pedestrian mode with a single gate opening and closing only (Master gate - MM1) as follows: By the input push-button-2 or by button (IV) in the remote controls. This button must be programmed into the CP for this purpose if required.

2.11 Safety Photo Beam Sensor Connections:

In order to reduce the current consumption of the system in the case of solar operated gates, the photo beam sensors are operated automatically by the control panel only during the closing cycle of the gate.

Thus, a 12v Dc photo beam sensors should be used, and the connections must be as follows: The **Normally Close** and the **Common** connections of the Photo Beam Sensor must be connected to Terminals No. 9 and 10 and the **POWER** to the photo sensor must be connected to terminals **7 & 8** in the control panel.

Model: CP-12 SOLAR INSTALLATION MANUAL

3. Installation of the solar panel

3.1 Follow the steps to assemble the post and the Solar Panel:

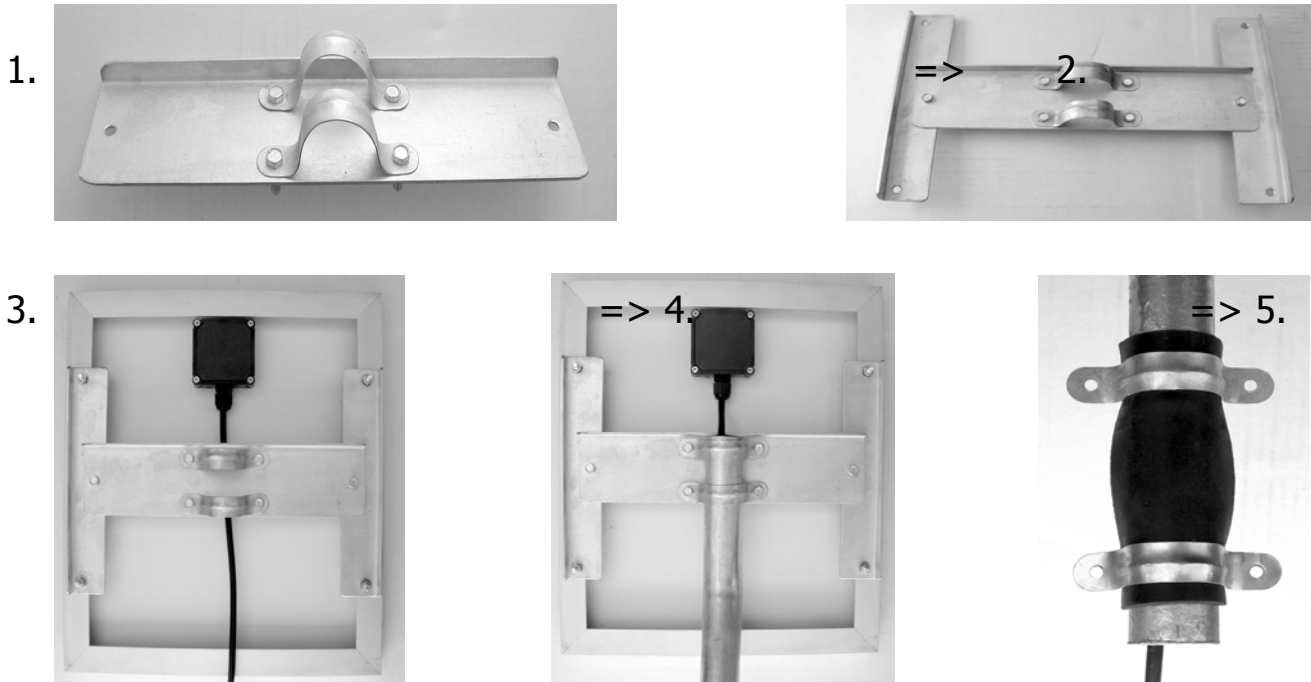

3.1 Installation:

1. The solar panel should be installed at 45° facing North.
2. Assemble and install the solar panel in a place that is exposed to the sun most of the day and as far as possible from any walls or trees.
3. Make sure that the two wires of the solar panel do not touch each other at any time during installation.
4. Install the solar panel at least 2m' above the ground to protect it from dust and small stones in windy days.
5. Install the control box on the wall and connect the batteries.
6. Run the solar panel's cable into the control box and connect it into its terminals with the right polarity; the RED wire is Positive (+) and the BLACK wire is Negative.

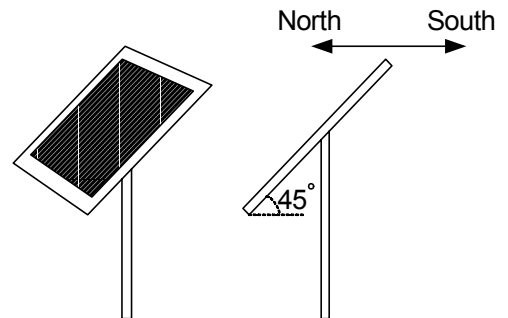

3.1 Connections:

1. Install the control box on the wall and connect the batteries.
2. Run the solar panel's cable into the control box and connect it into its terminals with the right polarity; the RED wire is Positive (+) and the BLACK wire is Negative.

ECA Electronic Engineering Pty. LTD.

Gate Operator Warranty and Exclusion of Liability Statement (“Statement”)

1. The gate operator kits of ECA Electronic Engineering Pty. LTD. carry a twelve-month warranty from the date of purchase (specified in the receipt of sales docket), which is subject to the matters set out below.
2. Subject to this Statement, ECA Electronic Engineering Pty. LTD. (“ECA”) warrants that the gate operator kit (the product) supplied by ECA will be free from any and all defects that would render the product un-merchantable.
3. This warranty (referred to above) applies only where:
 - (a) the purchaser seeking to rely on the warranty presents the relevant sales docket to the retailer from whom the product was purchased to confirm the date of purchase;
 - (b) a qualified installer by ECA for of gate operators has performed the installation;
 - (c) the purchaser notifies ECA or the retailer from whom the product was purchased of the alleged defective product immediately upon experiencing or learning of the alleged defect; and
 - (d) ECA determines, in its absolute discretion, that the product has a defect.
4. Except for the express warranty against defect set out above, ECA:
 - (a) gives no warranty about the product of any kind whatsoever, whether express or implied; and
 - (b) expressly excludes all warranty set out in Part V of the *Trade Practices Act 1974* to the maximum extent permitted by law.
5. Without limiting the generality of clause 4, ECA disclaims any liability of any nature in respect of any claim or demand for damages or costs or loss which arises out of:
 - (a) Accidental damage or normal wear and tear to the product or to the product’s component;
 - (b) Flood, fire, strong winds or lightning;
 - (c) Incorrect, improper or unreasonable maintenance and or use;
 - (d) Installation, adjustment or use, other than by ECA, which is not in accordance to the supplied instructions; or
 - (e) Attempted or completed modifications or repairs to the product carried out by a person who is not authorized by ECA to carry out such modifications or repairs.
6. ECA’s liability under the warranty set out above is limited, at ECA’s absolute opinion, to:
 - (a) replacing the product; or
 - (b) refunding the cost of purchasing the product.
7. Wherever the product is retailed by any person other than ECA, such person has no authority whatsoever from ECA to give any warranty or guarantee on any ECA product in addition to the warranty set out above.

ECA ELECTRONIC ENGINEERING Pty. LTD.

465 Hawthorn Rd. Caulfield Sth. 3162 Vic. Australia.

Tel: + 61 3 95720535 Fax: 95720536

www.gatesonsolar.com