

Company Profile



1986



1990



1995



1999



Centurion Systems (Pty) Ltd
Today

**In-house
R & D
development
team**



**Manufacture to
international
quality standard
ISO 9001:2008**



oas
INTERNATIONAL
REGISTERED FOR EXPORT
ISO 9001 : 2008

**100%
testing to
specifications**



**Competent
after-sales
technical support**

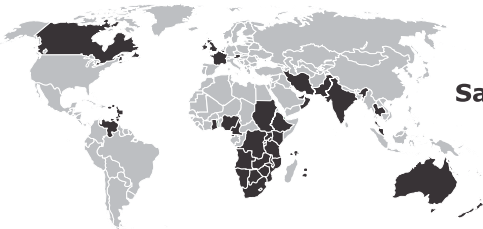

**Sales and technical support
to over 50 countries
worldwide**

CENTURION SYSTEMS (Pty) Ltd reserves the right to make changes to the products described in this manual without notice and without obligation of CENTURION SYSTEMS (Pty) Ltd to notify any persons of any such revisions or changes. Additionally, CENTURION SYSTEMS (Pty) Ltd makes no representations or warranties with respect to this manual. No part of this document may be copied, stored in a retrieval system or transmitted in any form or by any means electronic, mechanical, optical or photographic, without the express prior written consent of CENTURION SYSTEMS (Pty) Ltd

Contents



Mechanical Setup	page 1
Electrical Setup	Page 2
Commissioning and handover	page 2



IMPORTANT SAFETY INSTRUCTIONS	page 3
--------------------------------------	--------

1. Declaration of conformity	page 5
2. General description	page 6
Lightning protection	page 7
3. Icons used in this booklet	page 7
4. Specifications	page 8
Physical dimensions	page 8
Technical specifications	page 9
Control card	page 10
Power supply	page 10
Power supply, wall box and control card assembly	page 10
Allowable gate mass	page 10
5. Product identification	page 12
6. Required tools & equipment	page 14
7. Preparation of site	page 15
General considerations for the installation	page 15
Strength of the pillar	page 16
Strength of the gate and gate bracket	page 19
The Mechano Kit installation options	page 20
8. Cabling requirements	page 22
9. Operator installation	page 23
Determine the gate bracket position	page 24
Adjust origin clamp	page 26
Inward swing gate Setup	page 27
Outward swing gate Setup	page 30
10. Determine gate swing angle	page 33
11. Allowable wind loading	page 34
12. Electrical Setup	page 35
Secure control box to wall	page 35
Connecting all wiring	page 35
Setting the Limits	page 36
13. Wiring diagram for closing safety beam	page 37
14. Wiring diagram for opening safety beam	page 38
15. Wiring diagram for external radio receiver and loop detector	page 39
16. Wiring diagram for other inputs	page 40
17. Wiring diagram for Master motor (MTRM)	page 41

18. Wiring diagram for Slave motor (MTRS)	page 42
19. Charger and Pillar Light connections	page 43
20. Setting up additional features	page 44
21. Menu navigation map	page 45
22. Controller features	page 48
23. Factory defaults schedule	page 58
24. Description of terminal functions	page 64
25. Diagnostics	page 67
Diagnostic LEDs	page 67
Gate status LEDs	page 67
LCD display	page 68
Buzzer feedback	page 69
26. Installation handover	page 70



Mechanical setup

These quick steps are for the experienced installer who needs a checklist to get a standard installation up and running in the minimum of time.

Detailed installation features and functions are referred to later in this manual.



Gather required tools and equipment Page 14



Heed necessary site considerations Page 15



Check cabling requirements Page 22



Mount the wall bracket Page 24



Install motor and link to gate Page 25



Mount controller enclosure and connect all wiring Page 35

Electrical setup



Set limit switches and/or fit mechanical endstops

Page 36



Commissioning and handover



Commission system

Page 70



Carry out professional handover to client

Page 70

FAST TRACK





IMPORTANT Safety Instructions

ATTENTION

To ensure the safety of people, it is important that you read all the following instructions. Incorrect installation or incorrect use of the product could cause serious harm to people.

The installer, being either professional or DIY, is the last person on the site who can ensure that the operator is safely installed, and that the whole system can be operated safely.



Warnings for the installer

CAREFULLY READ AND FOLLOW ALL INSTRUCTIONS before beginning to install the product.

- All installation, repair, and service work to this product must be carried out by a suitably qualified person
- This appliance is not intended for use by persons (including children) with reduced physical, sensory or mental capabilities, or lack of experience and knowledge, unless they have been given supervision or instruction concerning use of the appliance by a person responsible for their safety
- Do not activate your gate unless you can see it and can determine that its area of travel is clear of people, pets, or other obstructions
- **NO ONE MAY CROSS THE PATH OF A MOVING GATE.** Always keep people and objects away from the gate and its area of travel
- **NEVER LET CHILDREN OPERATE OR PLAY WITH THE GATE CONTROLS**
- Secure all easily accessed gate opener controls in order to prevent unauthorised use of the gate
- Do not in any way modify the components of the automated system
- Do not install the equipment in an explosive atmosphere: the presence of flammable gasses or fumes is a serious danger to safety
- Before attempting any work on the system, cut electrical power to the operator and disconnect the batteries
- The mains power supply of the automated system must be fitted with an all-pole switch with contact opening distance of 3mm or greater. Use of a 5A thermal breaker with all-pole circuit break is recommended

- Make sure that an earth leakage circuit breaker with a threshold of 30mA is fitted upstream of the system
- Never short circuit the battery and do not try to recharge the batteries with power supply units other than that supplied with the product, or by CENTSYS
- Make sure that the earthing system is correctly constructed, and that all metal parts of the system are suitably earthed
- Safety devices must be fitted to the installation to guard against mechanical movement risks such as crushing, dragging and shearing
- It is recommended that at least one warning indicator light be fitted to every system
- Always fit the warning signs visibly to the inside and outside of the gate
- The installer must explain and demonstrate the manual operation of the gate in case of an emergency, and must hand the User/Warnings guide over to the user
- Explain these safety instructions to all persons authorised to use this gate, and be sure that they understand the hazards associated with automated gates
- Do not leave packing materials (plastic, polystyrene, etc.) within reach of children as such materials are potential sources of danger
- Dispose of all waste products like packaging materials, worn out batteries, etc, according to local regulations
- Always check the obstruction detection system, and safety devices for correct operation
- CENTSYS does not accept any liability caused by improper use of the product, or for use other than that for which the automated system was intended
- This product was designed and built strictly for the use indicated in this documentation. Any other use, not expressly indicated here, could compromise the service life/operation of the product and/or be a source of danger
- Everything not expressly specified in these instructions is not permitted

Safety FIRST

WARNING! WARNING! WARNING! WARNING! WARNING!



**MOVING GATE CAN CAUSE SERIOUS INJURY OR DEATH!
KEEP CLEAR! GATE MAY MOVE AT ANY TIME!
DO NOT ALLOW CHILDREN TO PLAY IN AREA
OR OPERATE GATE.**

1. Declaration of conformity

Manufacturer:

Centurion Systems (Pty) Ltd
Unit 13 Production Park
Intersection Newmarket Road & Epsom Avenue
North Riding
Gauteng
South Africa

Declares that the product:

Product name: **VECTOR2** Swing gate operator

Product options: All variants

Conforms with the following specifications:

Safety: SANS 60335-1:2007
IEC 60335-1:2006

Emissions: CISPR 22 CLASS B: Radiated emissions – 30MHz to 1000MHz
CISPR 22 CLASS B: Conducted emissions – 150 KHz to 30MHz

Immunity: IEC 61000-4-2 – Electrostatic discharge
IEC 61000-4-3 – Radiated immunity – 80MHz to 1000MHz
IEC 61000-4-4 – Electrical fast transients/burst
IEC 61000-4-5 – Surge immunity test
IEC 61000-4-6 – Conducted immunity – 150KHz to 80MHz
IEC 61000-4-8 – Power frequency magnetic field
IEC 61000-4-11– Voltage dips and interruption

Standard to which conformity is declared:

IEC 60335-1:2006	Safety
IEC 61000-6-3	Emissions
IEC 61000-6-1	Immunity

Signed at North Riding, South Africa on June 21, 2010



Ian Rozowsky
Research & Development Director.

2. General description

The **VECTOR2** operator has been designed to safely and cost-effectively automate a wide variety of swing gates, from single light-domestic swing gates to heavy industrial double swing gates.

The fail-safe and fully redundant position and Collision Detection system has been designed and tested to set the standard in safety of operation and to provide an unparalleled level of reliability and durability in operation.

The gate Travel Limits are managed by a sealed double-redundant opto-electronic system that has been designed not only to ensure ultra-reliable operation, but also to ensure precise position and trajectory control. This enables very accurate and reliable collision detection to ensure safe operation even under trying conditions.

The **VECTOR2** control card has been designed to be easy and intuitive to use with helpful instructions on the status of the operation during and after the installation. It also has a built-in diagnostic procedure that can verify every aspect of the control card on site.

Some of the advanced features offered by the **VECTOR2** controller are:

- Fully automated single button Limit Setup for single and double swing gates
- Full graphics LCD display provides an intuitive user interface with built-in diagnostics to speed up and simplify the installation process
- Separate safety inputs for sensitive edges or beams on both the closing and opening directions of the gate
- Advanced closed-loop speed control to maintain safe and reliable operation on inclined gates under windy conditions
- Fully configurable gate Run Profiles
- Selectable and adjustable Autoclose with pushbutton override
- Pedestrian (Partial) opening with automatic closure
- Free-exit input
- Positive Close Mode
- Multiple Modes of Operation
- Solenoid lock drive output up to 2A
- Holiday Lockout
- A status LED output to indicate the gate status remotely
- Pillar Light control
- Leaf delay selectable for either gate leaf
- Onboard CENTURION receiver with selective adding and deleting of remotes

Lightning protection

The **VECTOR2** electronic controller utilises the same proven surge protection philosophy that is used in all CENTSYS products. While this does not guarantee that the unit will not be damaged in the event of a lightning strike or power surge, it greatly reduces the likelihood of such damage occurring. The earth return for the surge protection is provided via the mains power supply earth. In order to ensure that the surge protection is effective, it is essential that the unit is properly earthed.

3. Icons used in this manual



This icon indicates tips and other information that could be useful during the installation



This icon denotes variations and other aspects that should be considered during installation



This icon indicates warning, caution or attention! Please take special note of critical aspects that **MUST** be adhered to in order to prevent injury

4. Specifications

Physical dimensions

Model V400

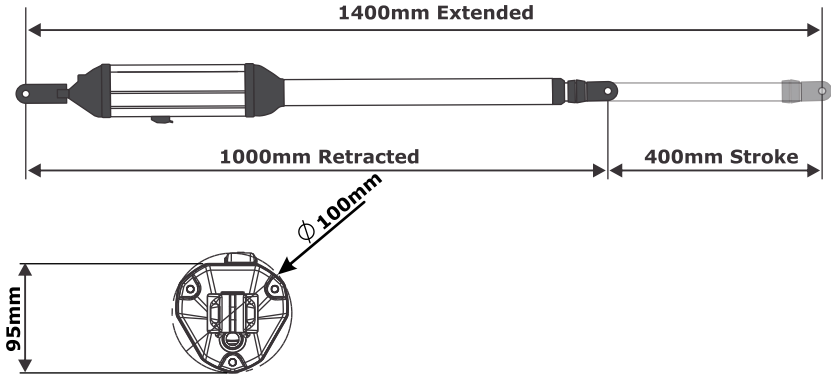

All dimensions shown in millimeters

FIGURE 1. OVERALL DIMENSIONS

Model V500

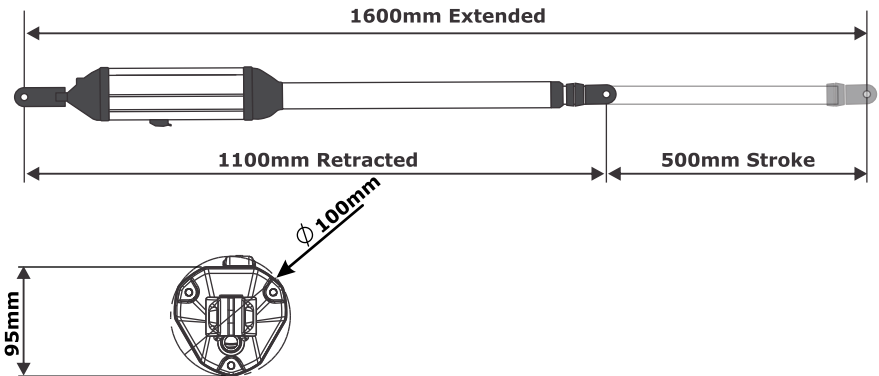

All dimensions shown in millimeters

FIGURE 2. OVERALL DIMENSIONS

Technical specifications

	VECTOR2 400	VECTOR2 500
Input voltage	220-240V AC ± 10%, 50Hz★	
Motor voltage	12V DC	
Motor power supply	Battery driven (standard capacity - 7Ah)†	
Battery charger★		
DomesticⓈ	CP84E - 800mA @ 13.8V	
Light-industrial①	CP84SM - 2A @13.8V	
Current consumption (mains)	60mAⓈ / 170mA①	
Current consumption (motor at rated load)	15A - max	
Operator push force - maximum	250kgf	
Operator stroke	400mm	500mm
Piston extension / retraction speed	27mm/sec	
Typical gate opening time‡	<14 sec	<17 sec
Manual override	Key release	
Maximum number of operations per day	100Ⓢ / 250①	
Duty cycle - mains present‡*	25%Ⓢ / 50%①	
Operations in standby with 7Ah battery‡		
Half day	70	
Full day	58	
Collision sensing	Electronic	
Controller solenoid output rating	2A DC	
Operating temperature range	-15°C to +50°C	
Onboard receiver type	CENTSYS code-hopping multichannel	
Receiver code storage capacity	64 transmitter buttons	
Receiver frequency	433MHz	
Mass of unit packed (excluding battery)		
Single kit	8.5kg	9kg
Double kit	14kg	15kg

★ Can operate off a solar supply, consult Centurion Systems (Pty) Ltd for assistance

† Can increase battery capacity for longer standby times

Ⓢ Based on 25°C ambient temperature and unit not in direct sunlight

* Based on an operator push force of less than 50% of rated

‡ Based on double kit excluding infrared safety beams

‡ Assumes a 90° opening gate and optimum mounting position

‡ Assumes full stroke of operator is used

Control card

Maximum motor current per channel	15A (fused)
Maximum input voltage	14.4V DC
Standby current draw	48mA
Maximum solenoid current draw	2A DC
Maximum aux output current	3A (PTC)
Collision detection	Current sense and redundant optical
Position and trajectory	Redundant optical
Temperature range	-20°C to +60°C

Power supply

	7Ah, 12V, CP84E (Domestic)	7Ah, 12V, CP84SM2A (Light -industrial)
Nominal input voltage	220-240V AC $\pm 10\%$ @ 50Hz	220-240V AC $\pm 10\%$ @ 50Hz
AC current draw (maximum)	60mA	170mA
Temperature Range	-20°C to +60°C	-20°C to +60°C
Max. continuous charging current	0.8A @ 13.8V	2.5A @ 13.8V

Power supply, wall box and control card assembly

	7Ah, 12V, CP84E (Domestic)	7Ah, 12V, CP84SM 2A (Light-industrial)
Boxed shipping weight (excluding batteries):	2.7kg	2.6kg
Protection Level	IP55	IP55

Allowable gate mass

Maximum allowable gate mass for V400 operator:

Gate swing angle	Up to 1.5m	Up to 2m	Up to 2.5m	Upto 3m(#1)	Up to 3.5m(#1)	Up to 4m(#1)
90°	500kg	500kg	500kg	360kg	260kg	200kg
100°	500kg	500kg	388kg	160kg	190kg	150kg
110°	500kg	306kg	198kg	130kg	Not recommended	
120°	180kg	100kg	65kg			

(#1 - an electric lock must be fitted to secure gate in closed position)

Maximum allowable gate mass for V500 operator:

Gate swing angle	Up to 1.5m	Up to 2m	Up to 2.5m	Upto 3m(#1)	Up to 3.5m(#1)	Up to 4m(#1)
90°	750kg	750kg	750kg	550kg	410kg	310kg
100°	750kg	750kg	600kg	420kg	310kg	230kg
110°	750kg	500kg	320kg	220kg	Not recommended	
120°	310kg	170kg	110kg			

(#1 - an electric lock must be fitted to secure gate in closed position)

5. Product identification

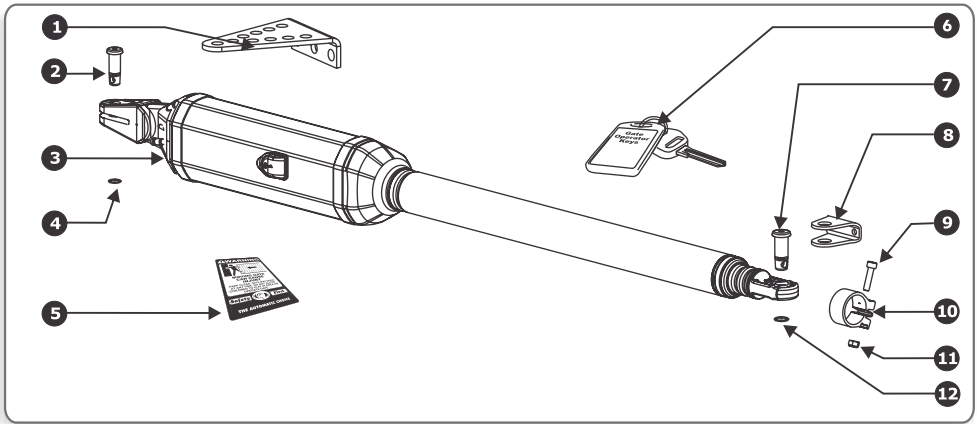

FIGURE 3. PRODUCT IDENTIFICATION

- | | |
|---|--------------------------------------|
| 1. Wall bracket (standard) | 7. Gate operator keys [‡] |
| 2. Wall bracket pin | 8. Gate bracket |
| 3. VECTOR2 gate operator (complete assembly) | 9. Stainless steel cap screw M6 x 25 |
| 4. 12mm snap ring | 10. Origin body |
| 5. Gate warning decal | 11. Stainless steel M6 nut |
| 6. Gate bracket pin | 12. 14mm snap ring |

[‡] Keys are specific to each operator-key number must be recorded.

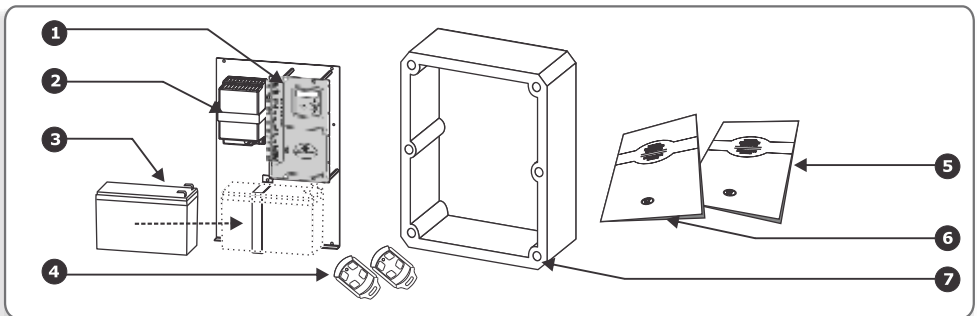

FIGURE 3A. CONTROL BOX INCLUDING CHARGER AND CONTROLLER

- | | |
|--|------------------------|
| 1. VECTOR2 controller with built-in receiver | 5. User guide |
| 2. Charger | 6. Installation manual |
| 3. 12V 7.2Ah Battery (user supplied - not part of kit) | 7. Wall box |
| 4. CENTSYS transmitters | |

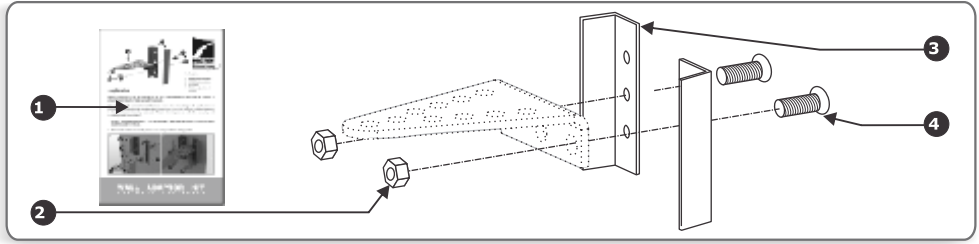

FIGURE 3B. WALL ADAPTOR KIT

1. **VECTOR2** wall adaptor kit packing leaflet
2. M10 Hexagon nuts
3. Wall adaptor plate
4. M10 x 20 Countersunk screw

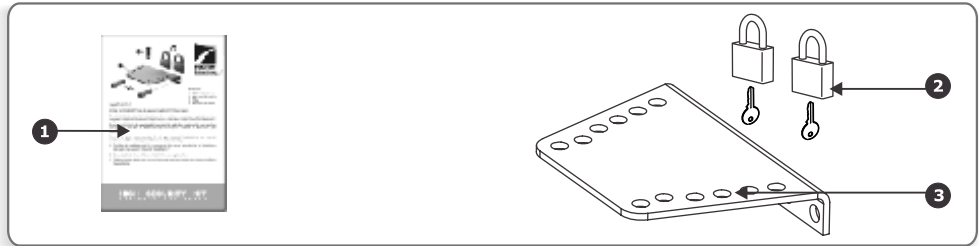

FIGURE 3C. HIGH SECURITY KIT

1. **VECTOR2** high security kit packing leaflet
2. Padlock
3. Wall bracket (high security)

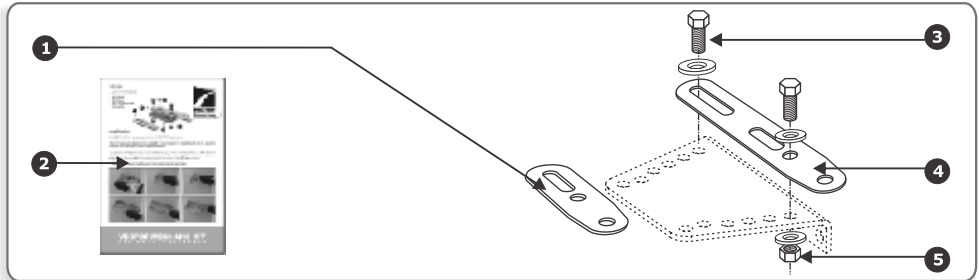

FIGURE 3D. MECHANO KIT

1. **VECTOR2** securing plate (short)
2. **VECTOR2** mechano kit packing leaflet
3. M10 x 35 Bolt
4. M10 x 35 Bolt
5. **VECTOR2** securing plate (long)

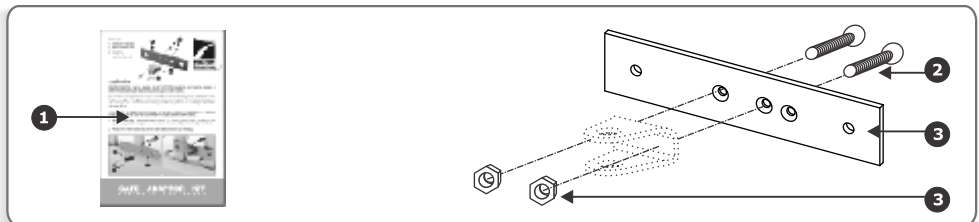

FIGURE 3E. GATE ADAPTOR KIT

1. **VECTOR2** gate adaptor kit packing leaflet
2. M6x16 Countersunk cap screw
3. Gate bracket spreader plate
4. M6 Hexagon nuts

6. Required tools and equipment

- Spanner - 17mm, 15mm, preferably socket set
- Crimping tool and pin lugs
- Hammer
- Electric drilling machine
- 20mm hole saw
- Screwdrivers - 6mm Philips, 3.5 Flat
- Pliers
- Connector block
- 2 x G-clamps
- Masonry bits - 12mm; 10mm for wall mount brackets; steel bits 6.5mm/10.5mm
- 6mm pin punch
- Angle grinder
- Measuring tape
- Hacksaw
- 5mm Allen key
- Welding machine (including consumables and safety equipment)
- Soldering iron
- Spirit level
- Extension cord
- Marking pen/chalk
- Safety equipment (goggles, gloves, etc.)

7. Preparation of site

General considerations for the installation

- Always recommend the fitment of additional safety equipment such as safety edges and safety beams, for additional protection against entrapment or other mechanical risks
- Check that no pipes or electrical cables are in the way of the intended installation
- Check that enough space is available for the gate operator with the gate in the required open position. (See Figure 4 and 5)
- Check the strength of the mounting pillar and fit a wall adaptor kit where needed
- If the swing gate leaf is longer than 2.5m, ensure that a lock can be fitted
- Never fit the operator on the outside of the gate, where the public has access to it (Follow the instructions for an outward opening swing gate, if required.)
- For greater security consider fitting an optional high security kit

Install the gate operator only if:

- It will not pose a hazard to the public
- There is sufficient clearance to a roadway and/or public thoroughfares
- The installation will meet all municipal and/or local authority requirements once completed
- The gate mass, leaf width, allowable wind loading and application is within the operator specifications (refer to the specification tables)
- The gate is in good working order, meaning:
 - that it swings freely;
 - does not move on its own if left in any position;
 - each gate leaf is strong and rigid
- It can be installed to have sufficient clearance between moving parts when opening and closing to reduce the risk of personal injury and entrapment
- Pushbuttons or key switches, when required, can be positioned so that the gate is in line of sight of the operator

Gate opening 90° or less

Operator	Wall (minimum)**	Pillar (maximum)*
V400	150mm	250mm
V500	150mm	335mm

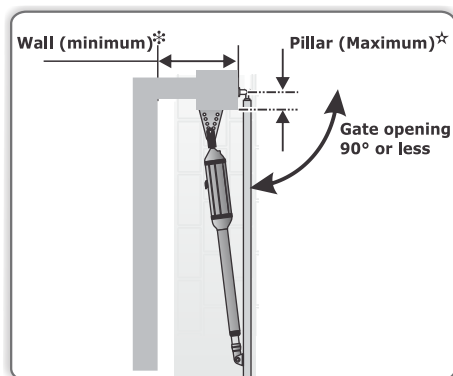

FIGURE 4

Gate opening 110°

Operator	Wall (minimum)*	Pillar (maximum)★
V400	150mm	145mm
V500	150mm	210mm

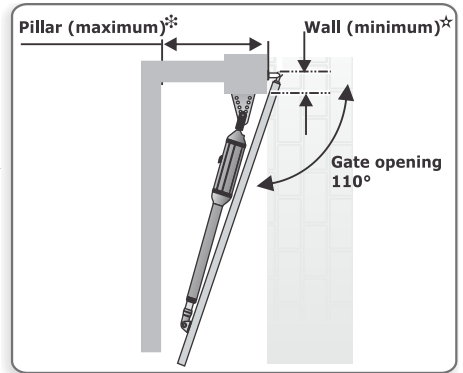

FIGURE 5

Tables are based on gates shorter than 2.5m

- For gates 2.5m to 3.0m long, reduce the maximum pillar thickness by 20mm
- For gates 3.0m to 3.5m long, reduce the maximum pillar thickness by 40mm
- For gates 3.5m to 4.0m long, reduce the maximum pillar thickness by 60mm

※ The typical minimum wall clearance required to fit the operator

★ The maximum allowable pillar thickness on which to fit the operator

Strength of the pillar



For reliable operation it is important to ensure that the way the operator is secured to the wall takes into account the strength of the pillar, the size of the gate, and how frequently the gate would be used:

High Security Kit together with a Wall Adaptor Kit

This mounting is highly recommended for all light-industrial gates, or for heavy gates of any length.

Alternatively it should be considered for use on pillars of low or unknown strength.

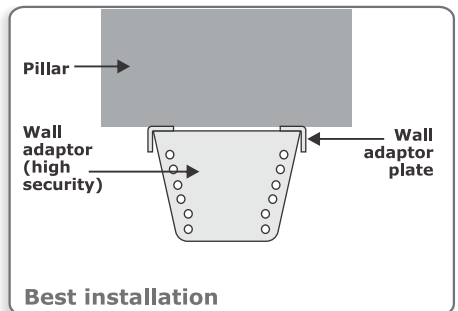

FIGURE 6

High Security Kit

This mounting works well for heavy gates shorter than about 2m in single household domestic applications.

Alternatively it should be considered for use on pillars of low or unknown strength.

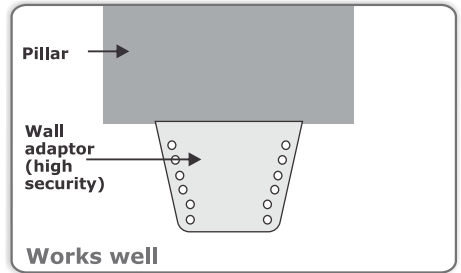

FIGURE 7

Standard bracket

This mounting means is typically used on light to medium weight domestic gates that are about 1.5m long, and that is mounted on pillars of average strength.

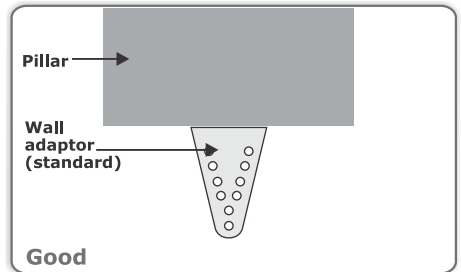

FIGURE 8



The means used to secure the bracket to the pillar is as important as the bracket itself

Through wall

Applications:

- Prefabricated walling
- For heavy gates operating frequently

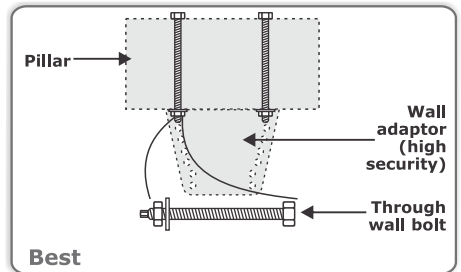

FIGURE 9

Chemical anchors

Applications:

- Masonry pillars
- Frequent use

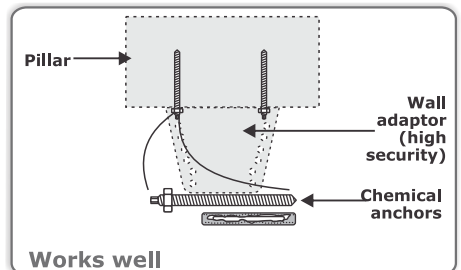

FIGURE 10

Welding

Applications:

- Lighter gates
- Domestic

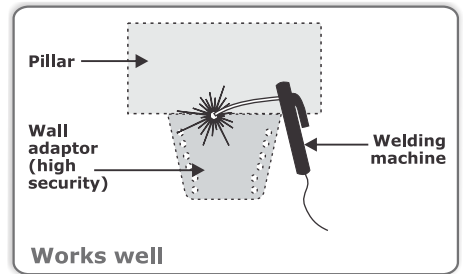

FIGURE 11

Sleeve anchors

Applications:

- Lighter gates
- Domestic

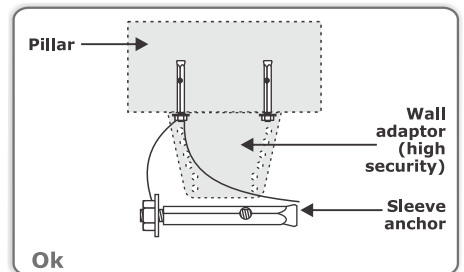

FIGURE 12

RAWL Bolts

Applications:

- Very light
- Very domestic

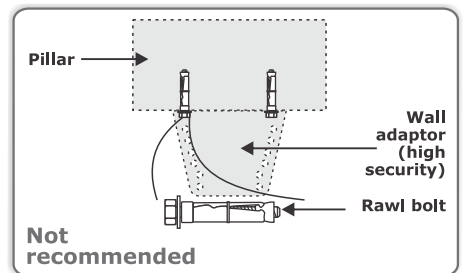

FIGURE 13

Strength of the gate and gate bracket

The gate adaptor kit both strengthens the connection to the gate, and also allows for more flexibility when mounting the bracket to the gate:

Welding Gate adaptor kit

Applications:

- Light-industrial
- Heavy gates
- Frequent use

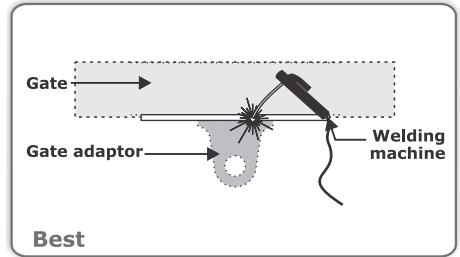

FIGURE 14

Through bolts Gate adaptor kit

Applications:

- Light-industrial
- Heavy gates
- Frequent use

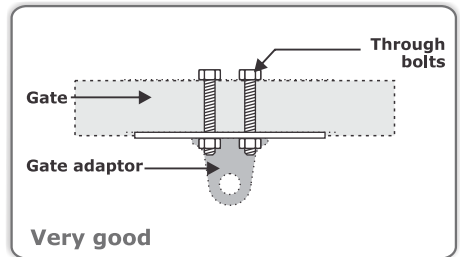

FIGURE 15

Welding

Applications:

- Domestic
- Medium gates
- Frequent use

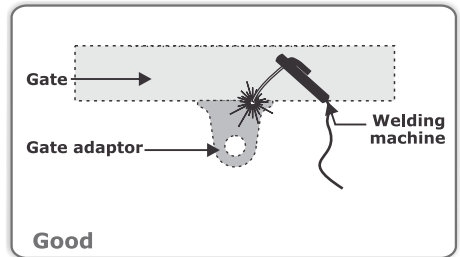

FIGURE 16

Through bolts (High tensile)

Applications:

- Domestic
- Light gates
- Infrequent use

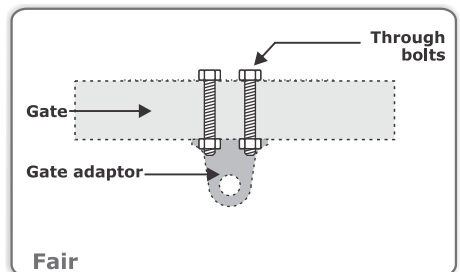

FIGURE 17



Tek screws and mild steel bolts are not recommended

The Mechano kit installation options

This kit is useful when fitting **VECTOR2** to existing installations, and also makes adjustments easier when doing new installations.

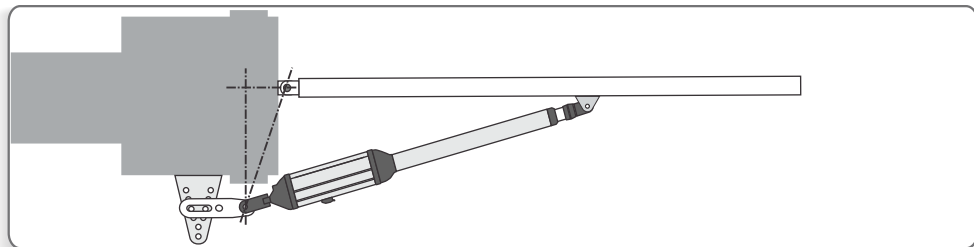

FIGURE 18. INSTALLATION WHEN THE PILLAR IS WIDE

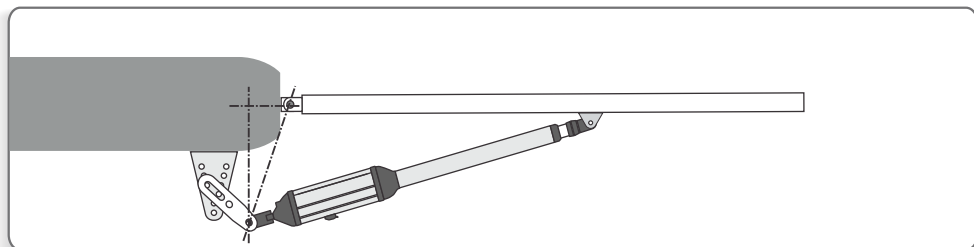

FIGURE 19. INSTALLATION WHEN THE PILLAR IS AN IRREGULAR SURFACE

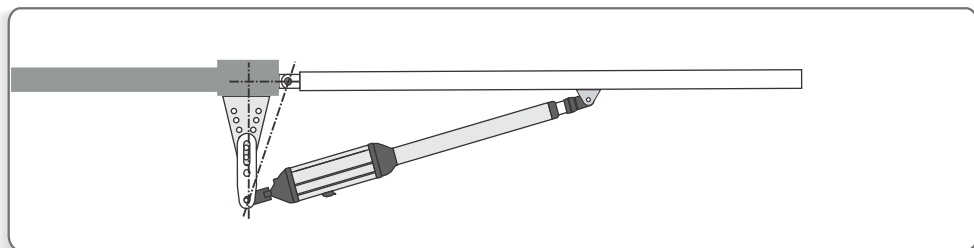

FIGURE 20. INSTALLATION ON A PALISADE FENCE

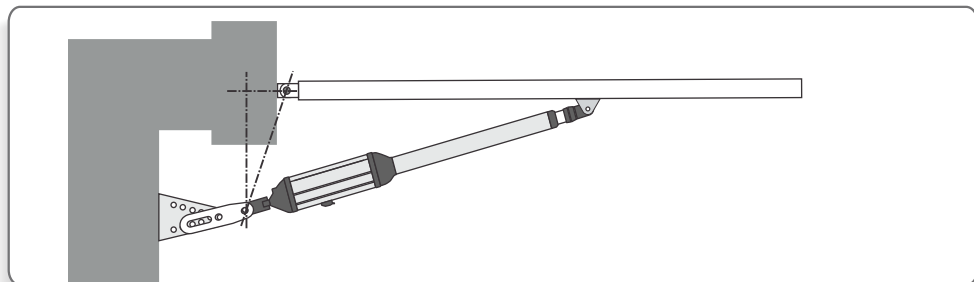

FIGURE 21. INSTALLATION ON AN ANGLED WALL

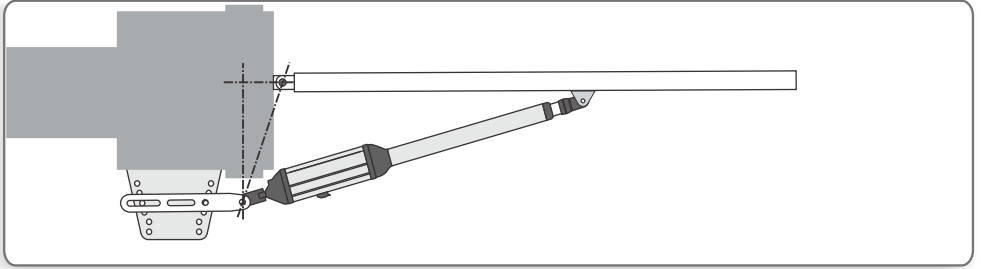

FIGURE 22. INSTALLATION WHEN THE PILLAR IS WIDE

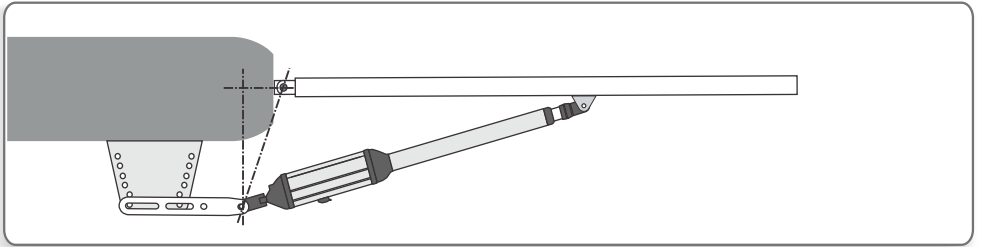

FIGURE 23. INSTALLATION WHEN THE PILLAR IS IRREGULAR SURFACE

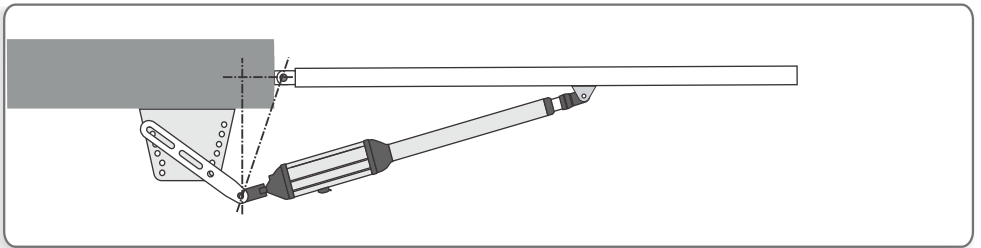

FIGURE 24. INSTALLATION ON A PALISADE FENCE

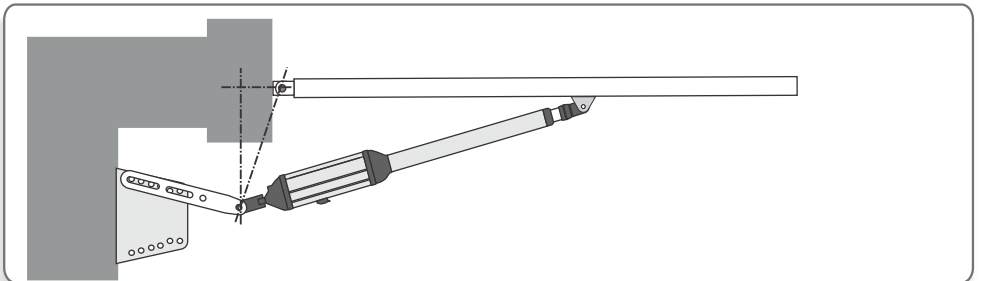

FIGURE 25. INSTALLATION ON AN ANGLED WALL

8. Cabling requirements

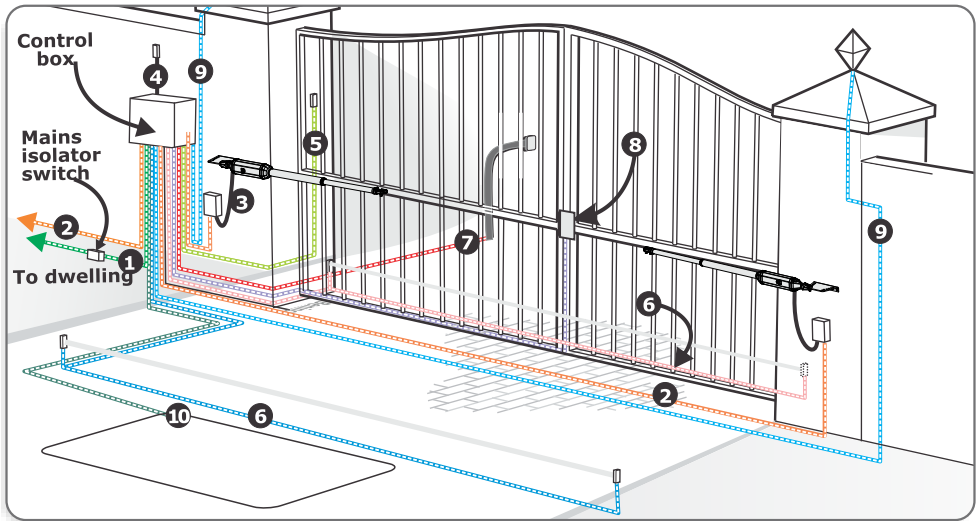

FIGURE 26. CABLING REQUIREMENTS

Legend

1. 220-240V AC mains cable via mains isolator[❖] switch (3 core LNE 0,5mm²)[☆]; or low-voltage 16V AC battery charger supply[✚] (2 core 1,5mm²).
2. Intercom cable (n1 + 6 core) to house.
3. Master motor (MTR M) or Slave motor (MTR S) cable (minimum, 2 core 2mm² + 4 core 0,5mm² multi-stranded) see note[✳]
4. Optional radio receiver cable (3 core 0,5mm² multi-stranded, optional)[✚]
5. Optional pedestrian key-switch (2 core 0,5mm² multi-stranded).or Optional keypad (3 core 0,5mm² multi-stranded).
6. Optional infrared beams or safety edge (3 core 0,5mm² multi-stranded or 4 core 0.5mm² for CE compliance.)
7. Optional intercom cable (n2+2 core 0,5mm² multi-stranded) to gate station
8. Optional electric lock (2 core 0.5mm²)
9. Optional Pillar Light cable (3 core, size according to power reg.)
10. Optional ground loop for free-exit (1core 0.5mm² multi-stranded - silicone-coated)[✚]

❖ Mains isolator must be fitted less than 1m from controller

☆ Increase cable thickness if Pillar Lights are to be installed.

★ Screened cable is always recommended to provide better protection against lightning - earth one end of screening.

✚ Domestic charger only.

✚ For optimum range an external receiver can be mounted on the wall.

✳ CENTSYS has available custom **VECTOR2** cable order reference: CABLEVEC68

✚ Consult manufacturer of loop detector for specific details



- All cables must be routed in conduit unless underground cable is being used
- Mains isolator must be less than 1m from the operator
- Safety beams are always recommended

9. Operator installation



To simplify the installation process, it is recommended that the existing gate is removed from the pillar before proceeding.

1. Determine gate opening angle and direction of operator (inward or outward).



Alternatively the swing angle can be determined more accurately with the process detailed on page 33

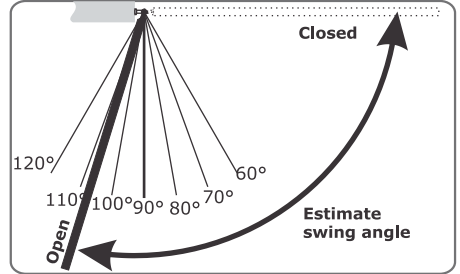

FIGURE 27. ESTIMATE SWING ANGLE

2. Determine a suitable height for the wall bracket.



The gate bracket must fit to a sturdy point on the gate. Consider using the optional gate adaptor kit



Take care to make sure the operator is mounted level

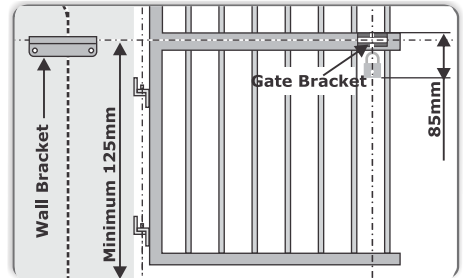

FIGURE 28. GATE HEIGHT

3. Determine where to put the bracket according to A and B values in the tables on pages 28, 29, 31 and 32.

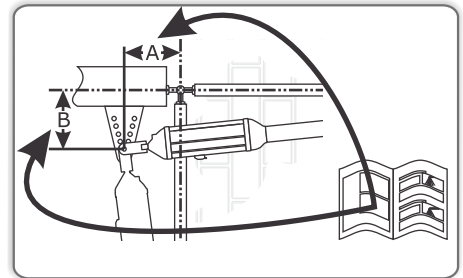

FIGURE 29. BRACKET POSITION

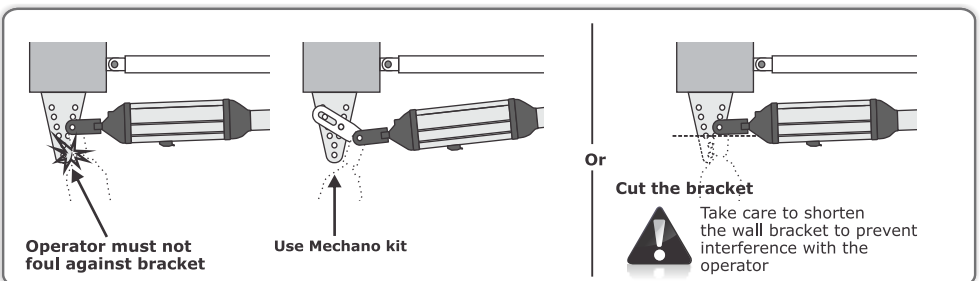

FIGURE 30. BRACKET POSITION

- Secure the bracket to the wall with the most appropriate means.



It is critical that the wall bracket is securely mounted



See page 15 for site considerations

Determine the gate bracket position



Start with the operator fully retracted

Turn out the actuator tube one or two turns

- Fit the gate bracket to the operator.

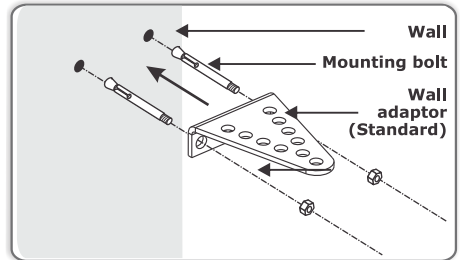

FIGURE 31

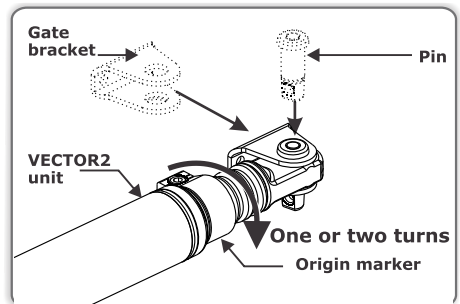

FIGURE 32

- Fit the motor end of the operator to the wall bracket.

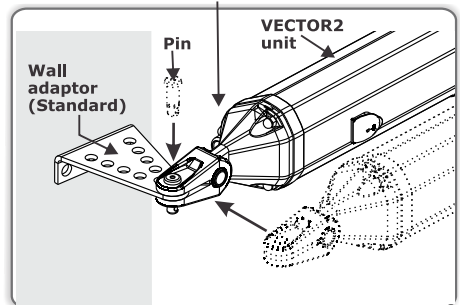

FIGURE 33

- Open the gate fully and temporarily clamp the gate bracket to the gate.



The gate bracket must fit to a sturdy point on the gate

Consider using the optional gate adaptor kit. See page 13

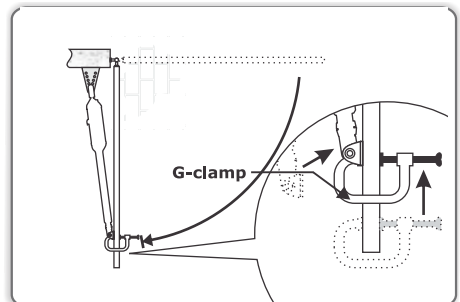

FIGURE 34

8. Unlock the operator and swing the gate closed.

9. Remove the pin and the operator from the bracket, check that there are at least one or two turns of the actuator before it is fully extended.



If it becomes obvious that the operator does not have enough stroke, reduce either the A or B distances by moving the wall



Be sure not to make the A and B values less than allowed for in the installation tables on page 28 and 29

In general:

- Large B distances give good security and good closing push force
- Small A and small B will increase the speed

Fasten gate bracket to gate

10. Secure the gate bracket using the most appropriate means.



It is critical that the gate bracket is securely mounted



See page 15 for site considerations

11. Fit operator, wall bracket pins and snap rings.



As an alternative to the snap ring, fit a padlock

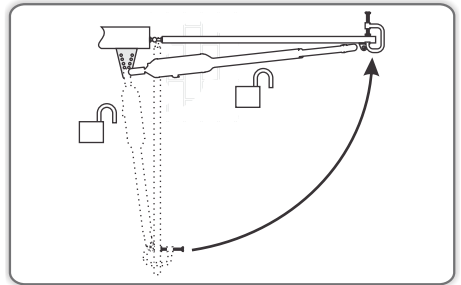

FIGURE 35

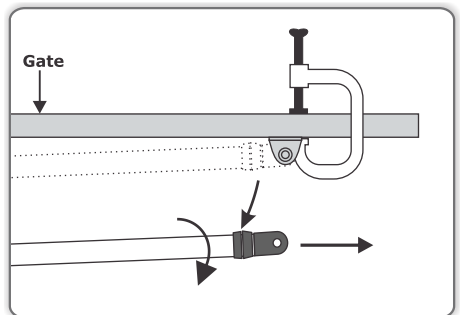

FIGURE 36

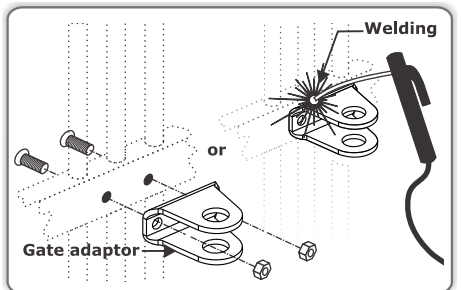

FIGURE 37

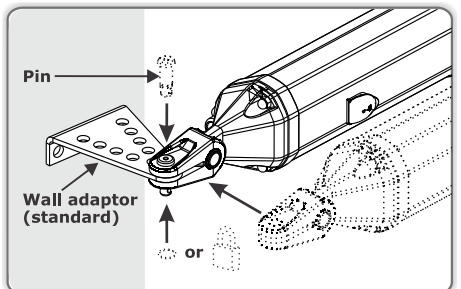

FIGURE 38

12. Fit operator, gate bracket pins and snap rings.



As an alternative to the snap ring, fit a padlock

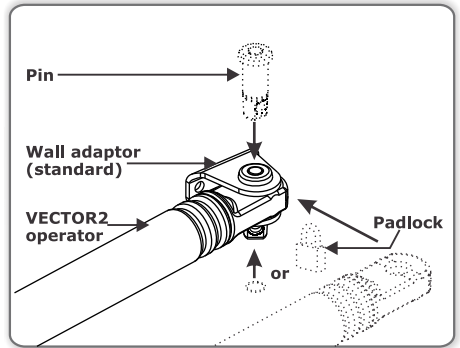

FIGURE 39

Adjust origin clamp

13. Unlock the operator and open the gate fully.
14. Slide the origin clamp along the actuator tube, right up to the operator. Secure in place with an Allen key and **tighten properly.**

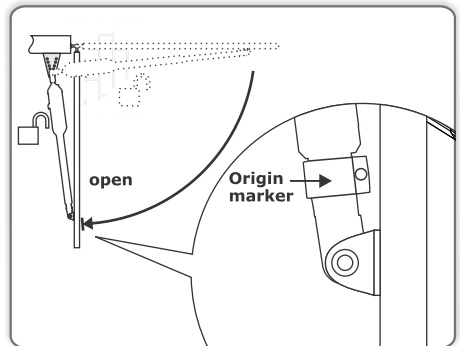

FIGURE 40

15. Attach warning decals to the gate as shown.

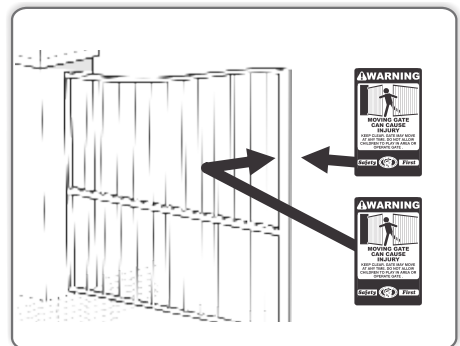

FIGURE 41

Inward swing gate Setup

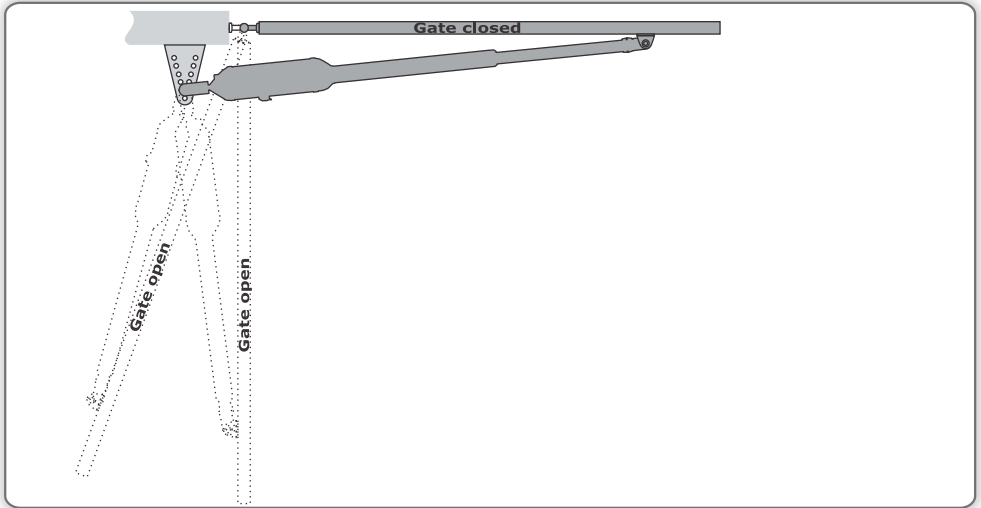

FIGURE 42



For gates opening 90° or less



For best security (but slower operation) install with large B value

For fast operation (but less security) install with small A and small B values



Ensure that the gate does not exceed the gate mass specifications on page 11



For gates opening more than 90°

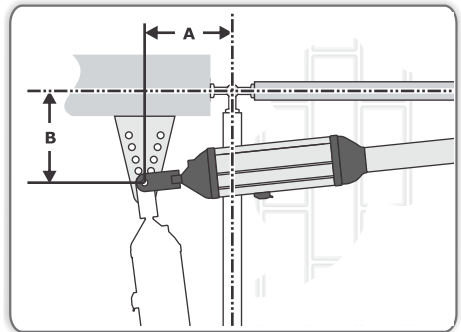

FIGURE 43

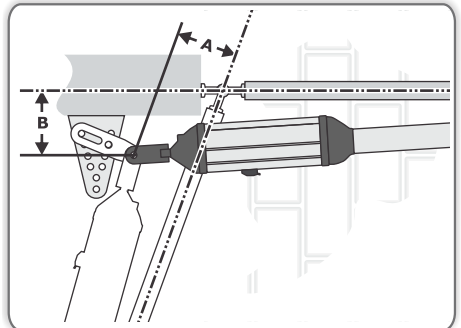

FIGURE 44

For V400 (400mm operator)

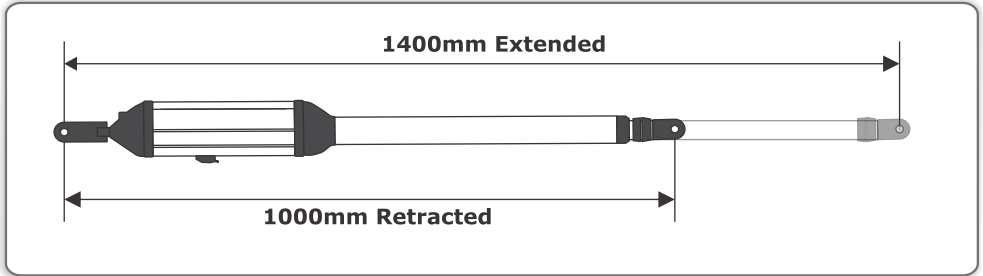

FIGURE 45

Recommended positions

(Only for a 2.5m gate or shorter)

Gate swing angle	A Value	B Value
90° or less	150	150
100°	155	155
110°	125	125
120°	110	110

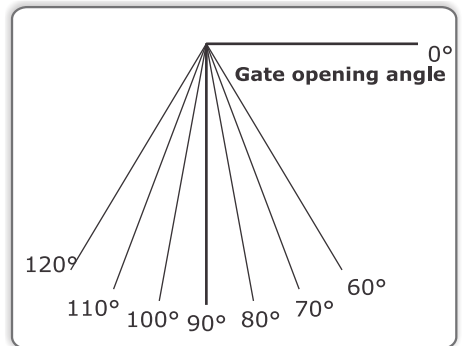

FIGURE 46

Alternative positions

Gate swing angle	A+B should not exceed	A and B must each be greater					
		Up to 1.5m	Up to 2m	Up to 2.5m	Up to 3m	Up to 3.5m	Up to 4m
60° - 90° or less	380mm	100mm	100mm	100mm	120mm	140mm	160mm
100°	325mm	100mm	100mm	100mm	120mm	140mm	160mm
110°	275mm	100mm	100mm	100mm	Not recommended		
120°	230mm	Not recommended					



100mm for A or B would ensure a 10mm clearance between the operator and gate if the gate is 50mm thick

For V500 (500mm operator)

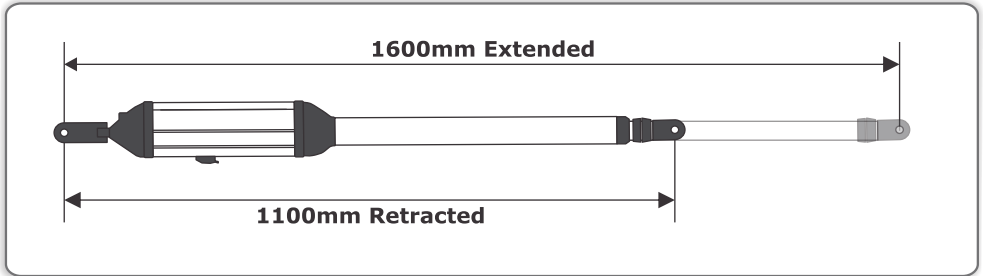

FIGURE 47

Recommended positions

(Only for a 2.5m gate or shorter)

Gate swing angle	A Value	B Value
90° or less	150	150
100°	155	155
110°	125	125
120°	110	110

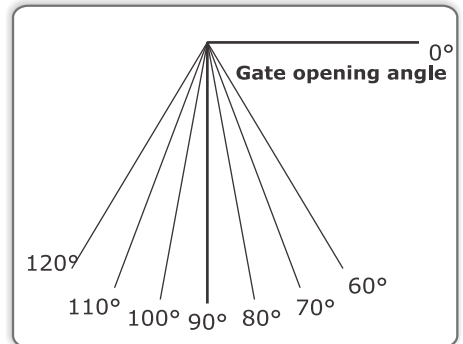

FIGURE 48

Alternative positions

Gate swing angle	A+B should not exceed	A and B must each be greater					
		Up to 1.5m	Up to 2m	Up to 2.5m	Up to 3m	Up to 3.5m	Up to 4m
60° - 90° or less	465mm	100mm	100mm	100mm	120mm	140mm	160mm
100°	400mm	100mm	100mm	100mm	120mm	140mm	160mm
110°	340mm	100mm	100mm	100mm	Not recommended		
120°	285mm	Not recommended					



100mm for A or B would ensure a 10mm clearance between the operator and gate if the gate is 50mm thick

Outward swing gate Setup



For gates opening 90° or less



For best security (but slower operation) install with large B value

For fast operation (but less security) install with small A and small B values



Ensure that the gate does not exceed the gate mass specifications on page 11



For gates opening more than 90°

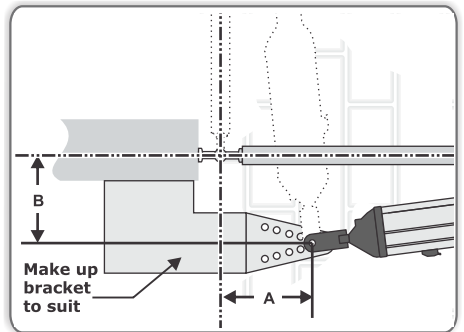

FIGURE 49

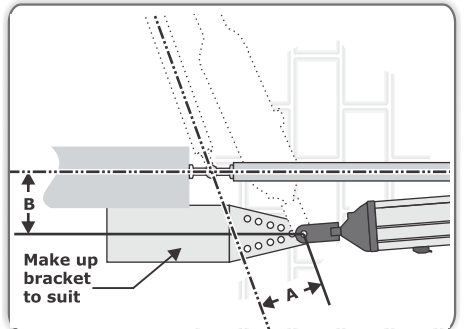
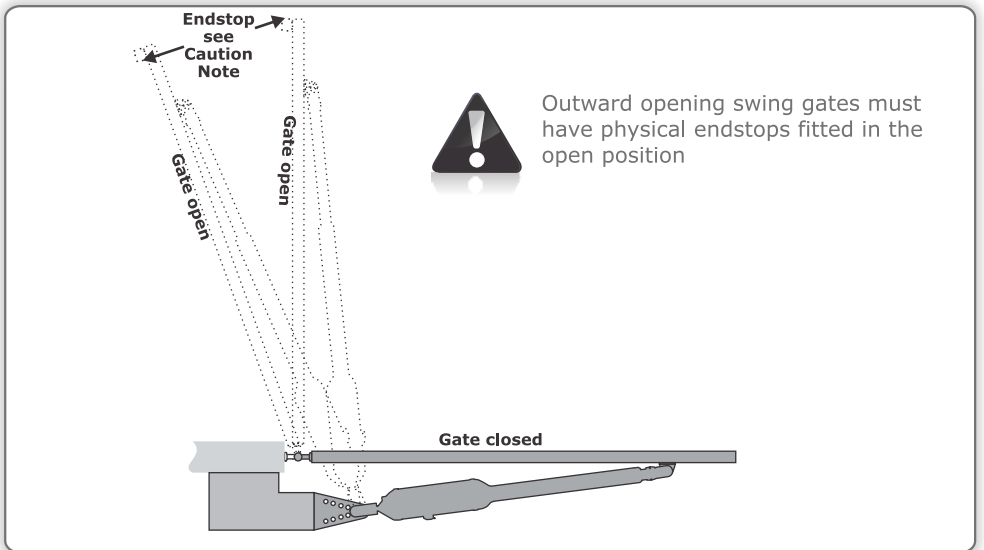

FIGURE 50



Outward opening swing gates must have physical endstops fitted in the open position

FIGURE 51

For V400 (400mm operator)

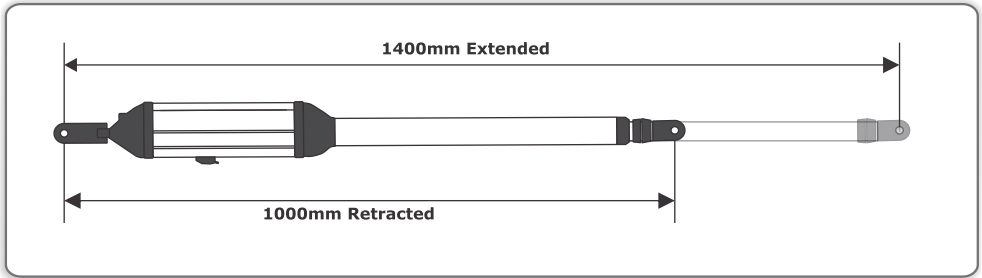

FIGURE 52

Recommended positions

(Only for a 2.5m gate or shorter)

Gate swing angle	A Value	B Value
90° or less	150	150
100°	155	155
110°	125	125
120°	110	110

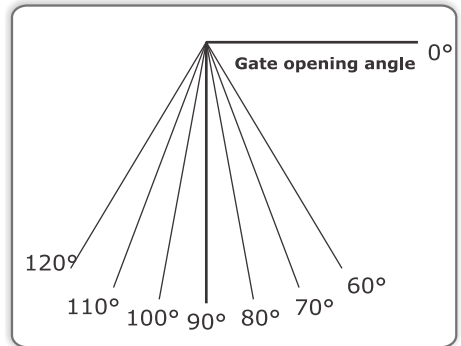

FIGURE 53

Alternative positions

Gate swing angle	A+B should not exceed	A and B must each be greater					
		Up to 1.5m	Up to 2m	Up to 2.5m	Up to 3m	Up to 3.5m	Up to 4m
60° - 90° or less	380mm	100mm	100mm	100mm	120mm	140mm	160mm
100°	325mm	100mm	100mm	100mm	120mm	140mm	160mm
110°	275mm	100mm	100mm	100mm	Not recommended		
120°	230mm	Not recommended					



100mm for A or B would ensure a 10mm clearance between the operator and gate if the gate is 50mm thick

For V500 (500mm operator)

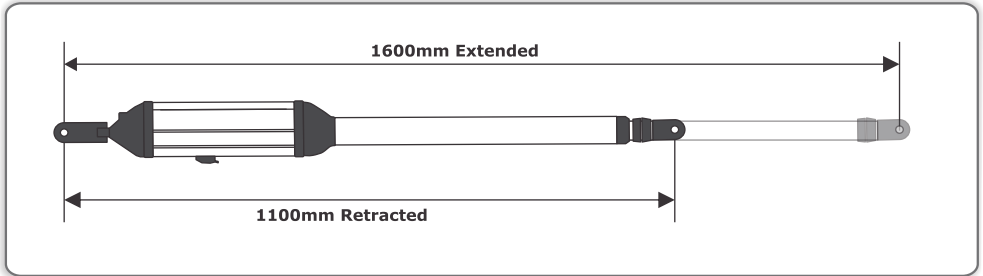

FIGURE 54

Recommended positions

(Only for a 2.5m gate or shorter)

Gate swing angle	A Value	B Value
90° or less	150	150
100°	155	155
110°	125	125
120°	110	110

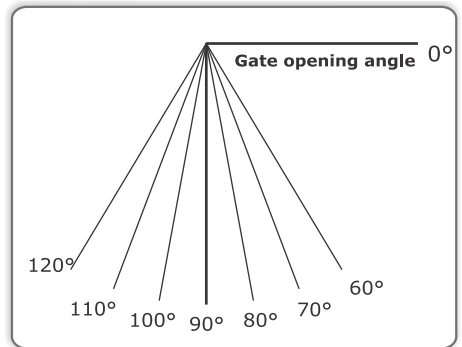

FIGURE 55

Alternative positions

Gate swing angle	A+B should not exceed	A and B must each be greater					
		Up to 1.5m	Up to 1.5m	Up to 2.5m	Up to 3m	Up to 3.5m	Up to 4m
60° - 90° or less	465mm	100mm	100mm	100mm	120mm	140mm	160mm
100°	400mm	100mm	100mm	100mm	120mm	140mm	160mm
110°	340mm	100mm	100mm	100mm	Not recommended		
120°	285mm	Not recommended					



100mm for A or B would ensure a 10mm clearance between the operator and gate if the gate is 50mm thick

10. Determine gate swing angle

Use this procedure to accurately determine the gate opening angle:

Step 1

1. Close the gate and measure a distance of 1m from the centreline of the gate hinge.
2. Make a mark on the ground.

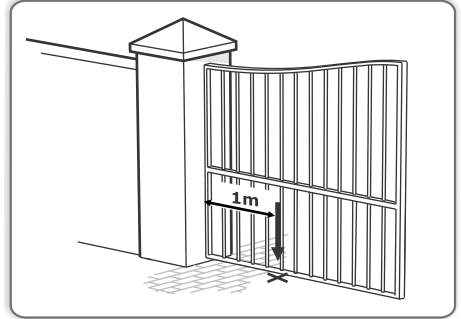

FIGURE 56

Step 2

3. Open the gate and measure a distance along the gate a distance of 1m from the centreline of the gate hinge.
4. Make a mark on the ground.
5. Measure the distance on the ground between the two marks (Z).
6. Using this Z value, read off the gate opening angle from the table below.

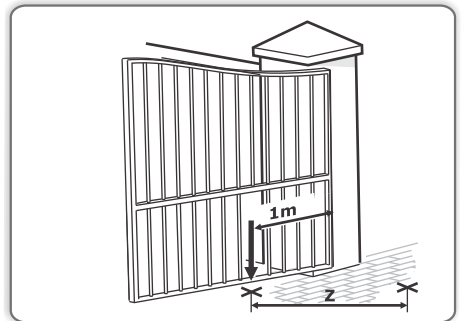

FIGURE 57

Step 3

Value z from	To	Use gate swing angle of
1 000mm	1 075mm	60°
1 075mm	1 218mm	70°
1 218mm	1 351mm	80°
1 351mm	1 475mm	90°
1 474mm	1 587mm	100°
1 587mm	1 687mm	110°
1 687mm	1 732mm	120°

11. Allowable wind load

Wind speeds for which operator will still operate the gate (for V400 or V500 operators)

For a 25% covered gate: (Palisades, etc.) x 1.8m high						
Value of A or B dimension once installed.*	Gate lengths:					
	Up to 1.5m	Up to 2m	Up to 2.5m	Up to 3m[★]	Up to 3.5m[★]	Up to 4m[★]
100mm	94km/h	66km/h	48km/h	44km/h	41km/h	37km/h
140mm	119km/h	85km/h	65km/h	57km/h	51km/h	46km/h
180mm	138km/h	101km/h	78km/h	67km/h	60km/h	53km/h
220mm	156km/h	114km/h	89km/h	76km/h	67km/h	60km/h
260mm	171km/h	126km/h	99km/h	84km/h	74km/h	65km/h
300mm	186km/h	137km/h	108km/h	91km/h	80km/h	71km/h
340mm	199km/h	147km/h	116km/h	98km/h	86km/h	76km/h

* See page 23 or 24 for installation details

★ An electric lock must be fitted

Wind speeds for which operator will still operate the gate (for V400 or V500 operators)

For a 100% covered gate: (Fully clad gates, etc.) x 1.8m high						
Value of A or B dimension once installed.*	Gate lengths:					
	Up to 1.5m	Up to 2m	Up to 2.5m	Up to 3m[★]	Up to 3.5m[★]	Up to 4m[★]
100mm	47km/h	33km/h	24km/h	22km/h	20km/h	19km/h
140mm	59km/h	43km/h	32km/h	28km/h	26km/h	23km/h
180mm	69km/h	50km/h	39km/h	34km/h	30km/h	27km/h
220mm	78km/h	57km/h	44km/h	38km/h	34km/h	30km/h
260mm	86km/h	63km/h	49km/h	42km/h	37km/h	33km/h
300mm	93km/h	68km/h	54km/h	46km/h	40km/h	35km/h
340mm	100km/h	74km/h	58km/h	49km/h	43km/h	38km/h

* See page 23 or 24 for installation details

★ An electric lock must be fitted

12. Electrical setup

1. Always check that the circuit breaker in the electrical panel is in the OFF position, and that all high voltage circuits (more than 42.4V) are completely isolated from the mains supply before doing any work.
2. Ensure that all low voltage systems (less than 42.4V) are suitably protected from damage, by disconnecting all sources of power such as chargers and batteries before doing any work.
3. All electrical work must be carried out according to the requirements of all applicable local electrical codes. (It is recommended that a licensed electrical contractor perform such work.)



Secure control box to wall

1. Secure the control box to the wall using the most appropriate means.

Be sure to position the wall box so as not to cause any hazards during and after the installation



Preferably mount the wall box:

- Out of direct sunlight
- At a comfortable working height
- Away from garden sprinklers etc
- To allow easy access even when the gate is open

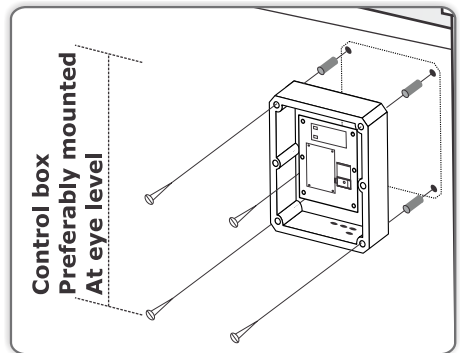

FIGURE 58

Connect all wiring

2. Connect all the cables as required to the control card. See pages 36, 37, 38 and 39.
3. When wiring each operator back to the controller housing, it is recommended to mount a small junction box adjacent each operator. Terminate the cable provided on the operator into this junction box and then route a new cable from the junction box to the controller housing.

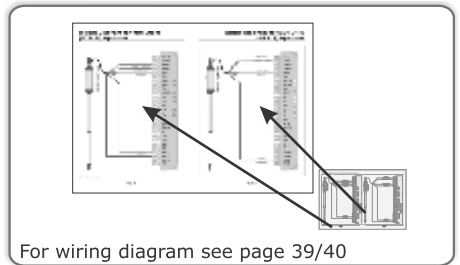

FIGURE 59

It is recommended that the installer tie off the harness in such a way so as to allow for a 350mm loop between the cable exit at the back of the operator and either the mounting bracket or junction box, to minimise the flexing of the harness. If a sharp bend is introduced to the cable harness, or a loop that is less than 350mm in diameter, the resulting cable fatigue may cause the actuators to behave erratically or to stop operating altogether

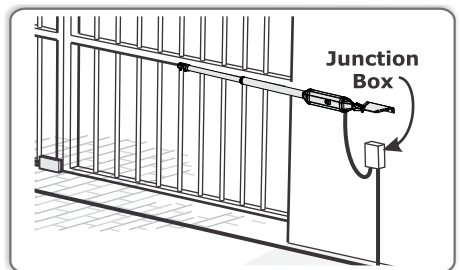

FIGURE 60

4. Check that the charger and battery are connected to the controller.



Ensure the battery polarity is correct

5. Switch on the mains supply (via isolator).
6. Ensure that both the controller and charger are effectively earthed for improved lightning protection.

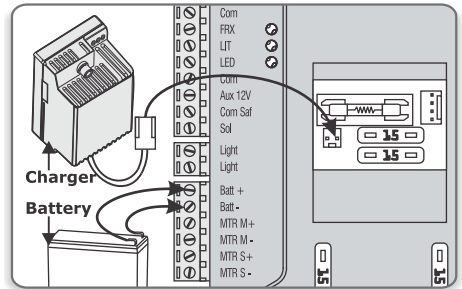

FIGURE 61

Setting the limits

7. Check that the origin has been correctly set. (See page 24).

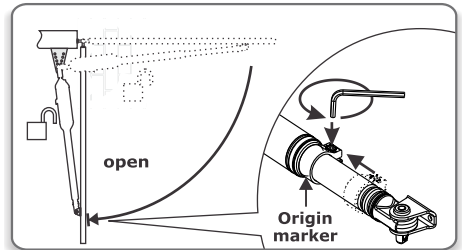

FIGURE 62

8. Check that the gate is closed and the operator is locked.
9. If powering up the system ex-factory, it will request for the operating PROFILE (operating standard) to be set. Select from the list the PROFILE that will suit the specific region. With this set, the system will automatically proceed to the limit setup menu. Follow the onscreen instructions to complete the setup procedure.

If powering up with the PROFILE set but no limits set, the system will automatically proceed to the limit setup menu. Follow the onscreen instructions to complete the setup procedure.

If powering up at any stage after that, push and hold the SETUP button () for 3 seconds.

For more details about the PROFILE (operating profile) – refer to page 53.

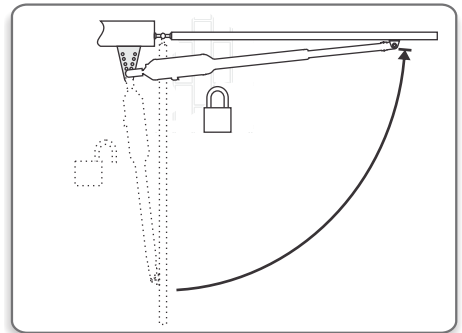

FIGURE 63



Select the "limits" menu by pressing the ENTER button (). Follow the onscreen instructions to complete the setup procedure

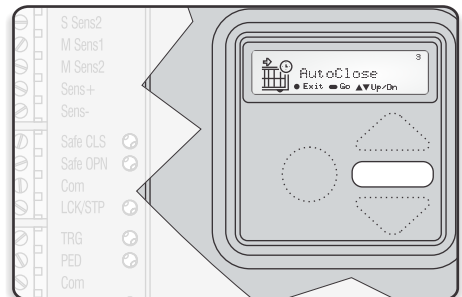

FIGURE 64

13. Wiring diagram for closing safety beam

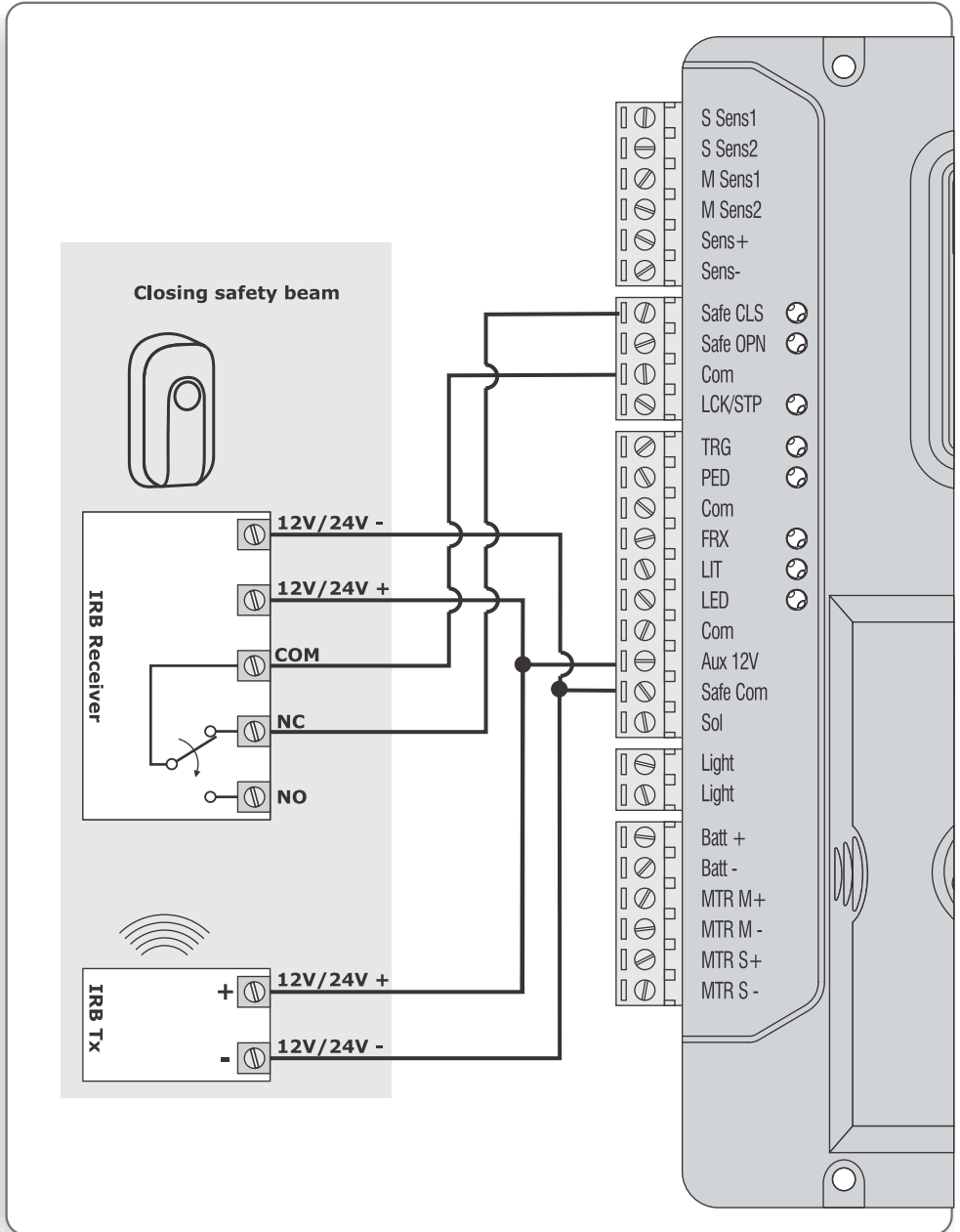

FIGURE 65. WIRING OF SAFETY DEVICE

14. Wiring diagram for opening safety beam

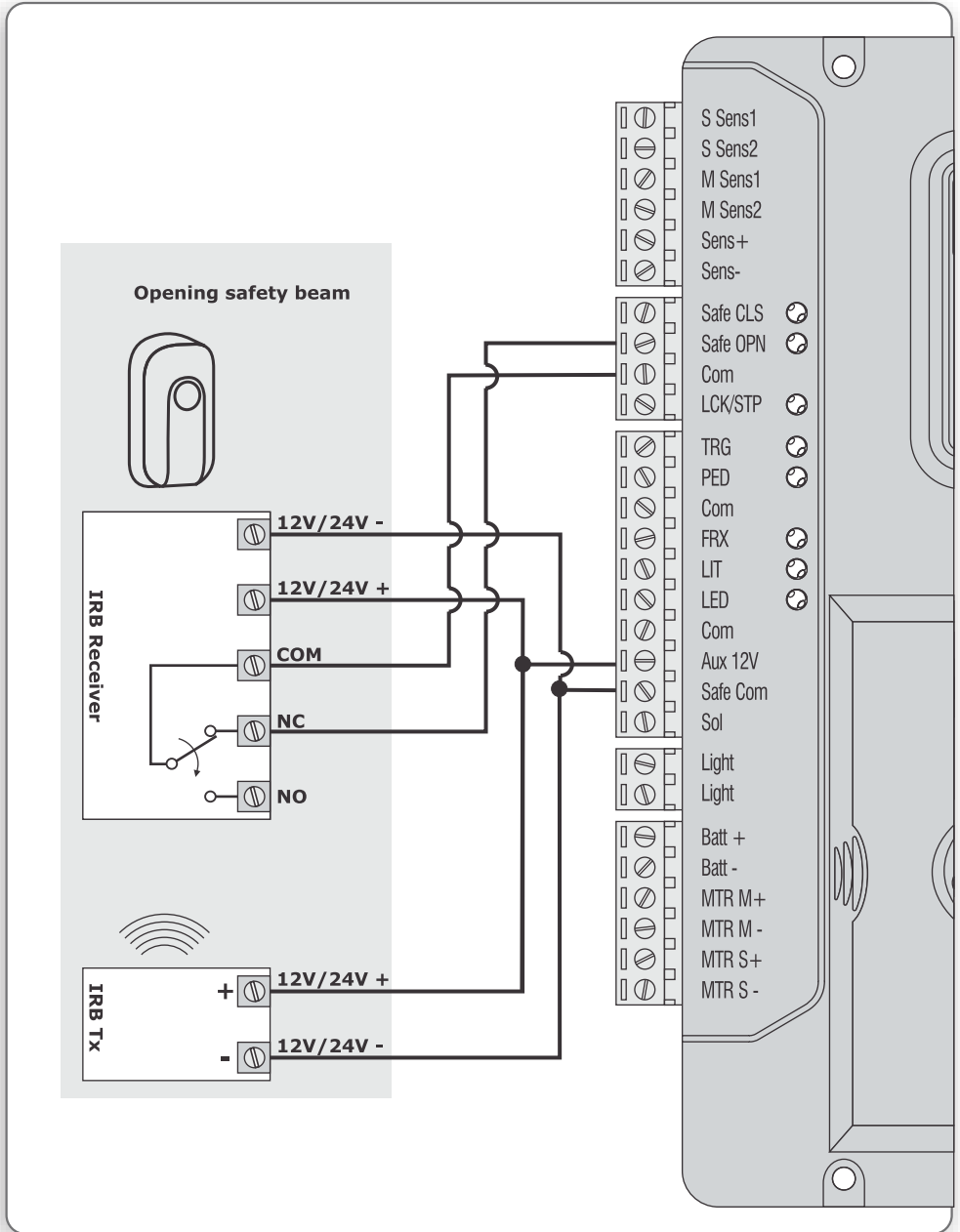
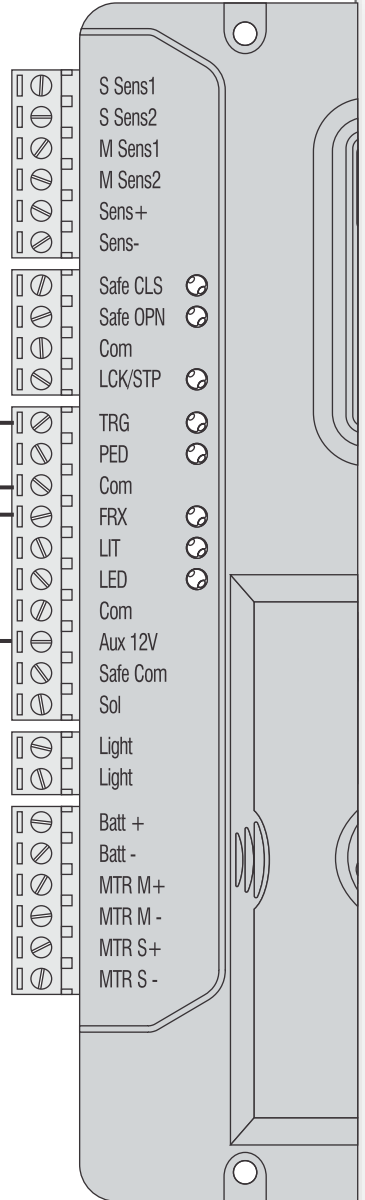
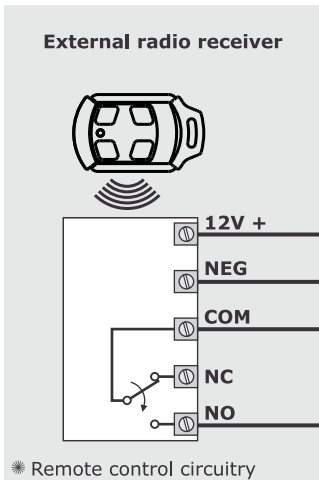
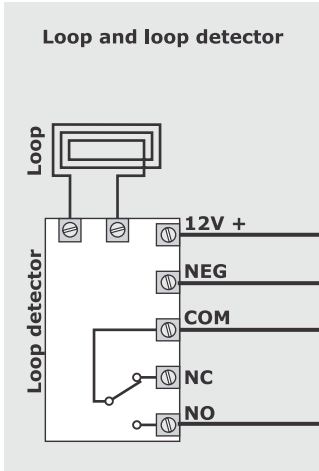

FIGURE 66. WIRING OF SAFETY DEVICE

15. Wiring diagram for external radio receiver and loop detector



* Refer to diagram only if external receiver is being used and not the onboard receiver, disable onboard receiver - Menu 11

FIGURE 67. WIRING OF OTHER INPUTS

16. Wiring diagram for other inputs

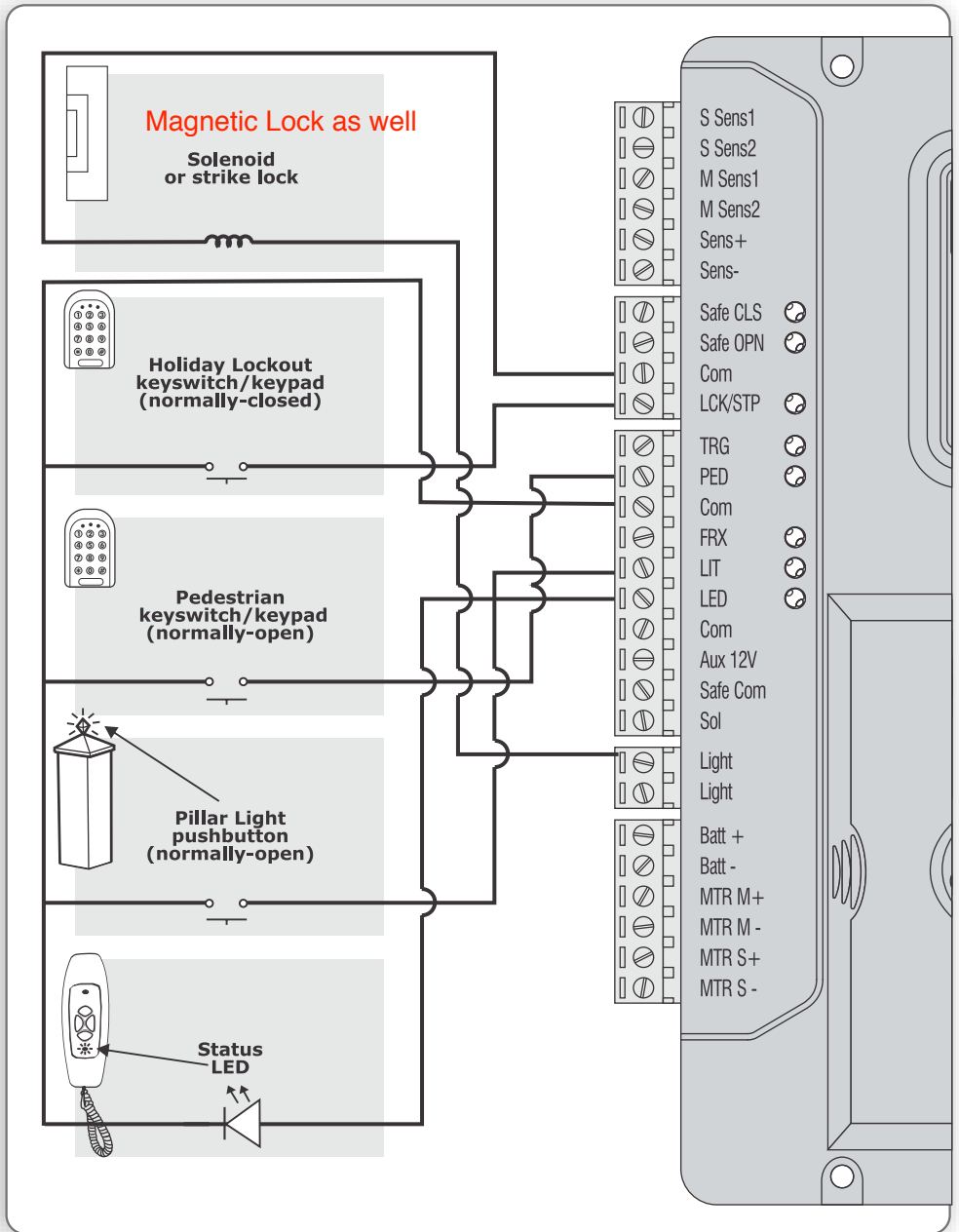

FIGURE 68. WIRING OF OTHER INPUTS

17. Wiring diagram for Master motor (MTRM)

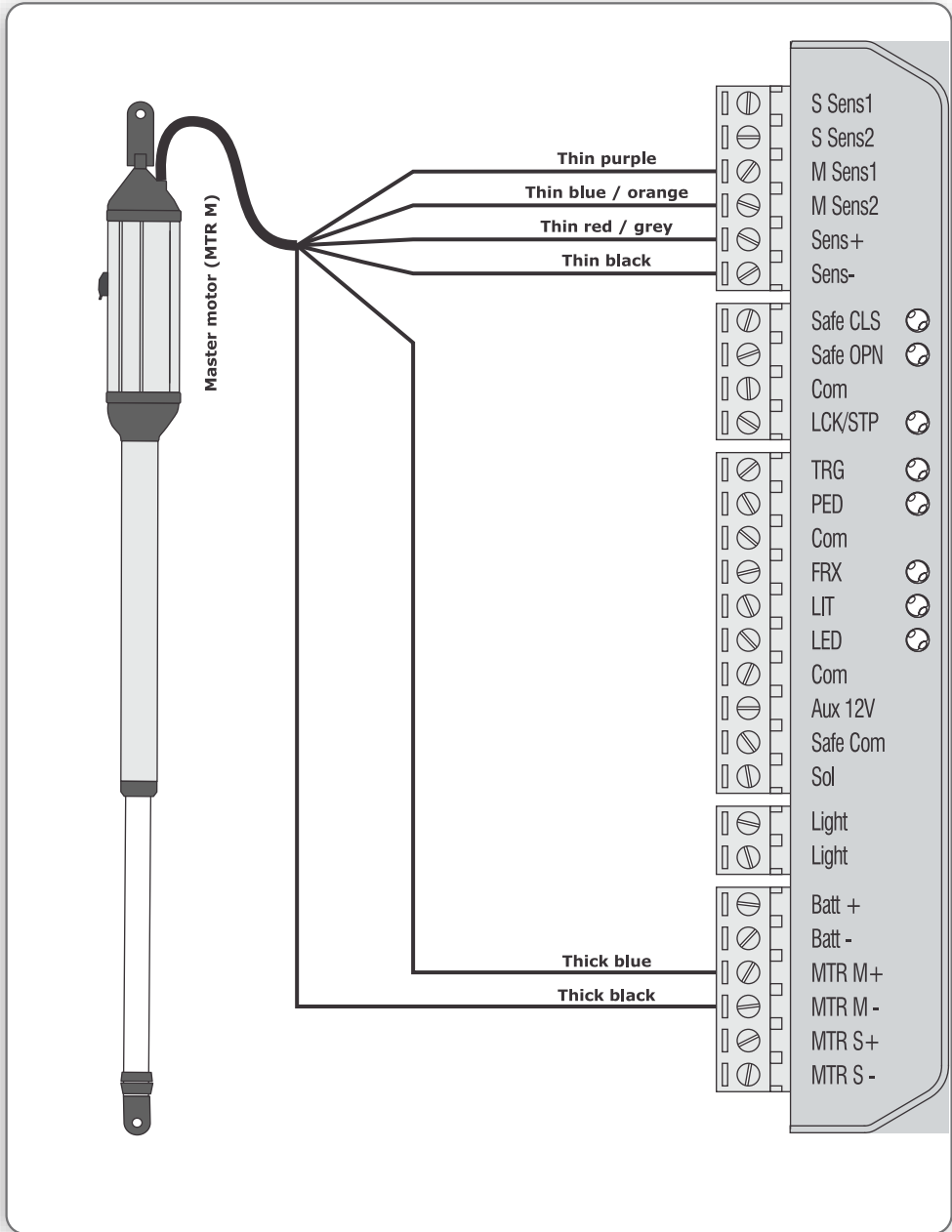

FIGURE 69. WIRING OF THE MASTER MOTOR

18. Wiring diagram for Slave motor (MTRS)

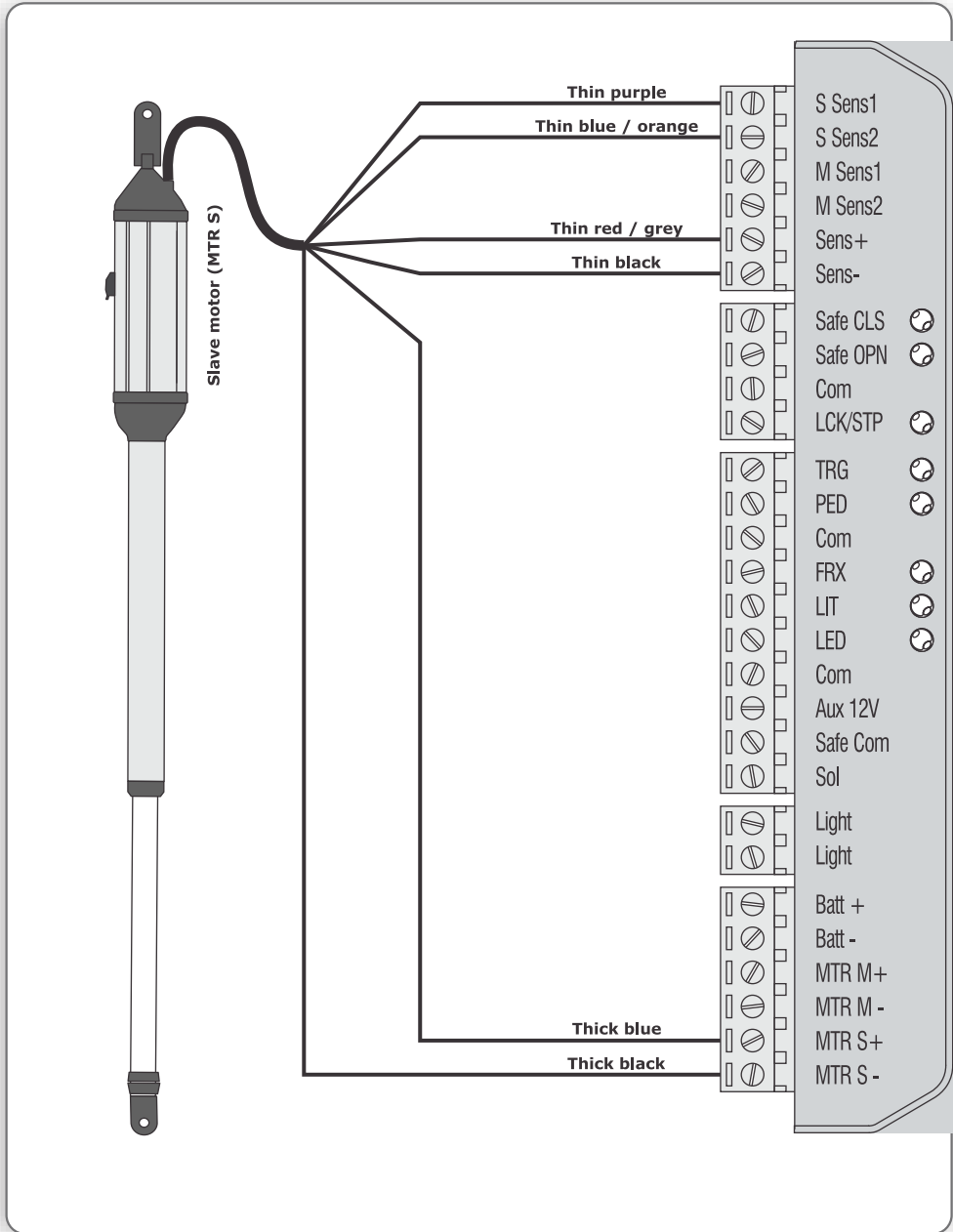

FIGURE 70. WIRING OF THE SLAVE MOTOR

19. Charger and Pillar Light connections

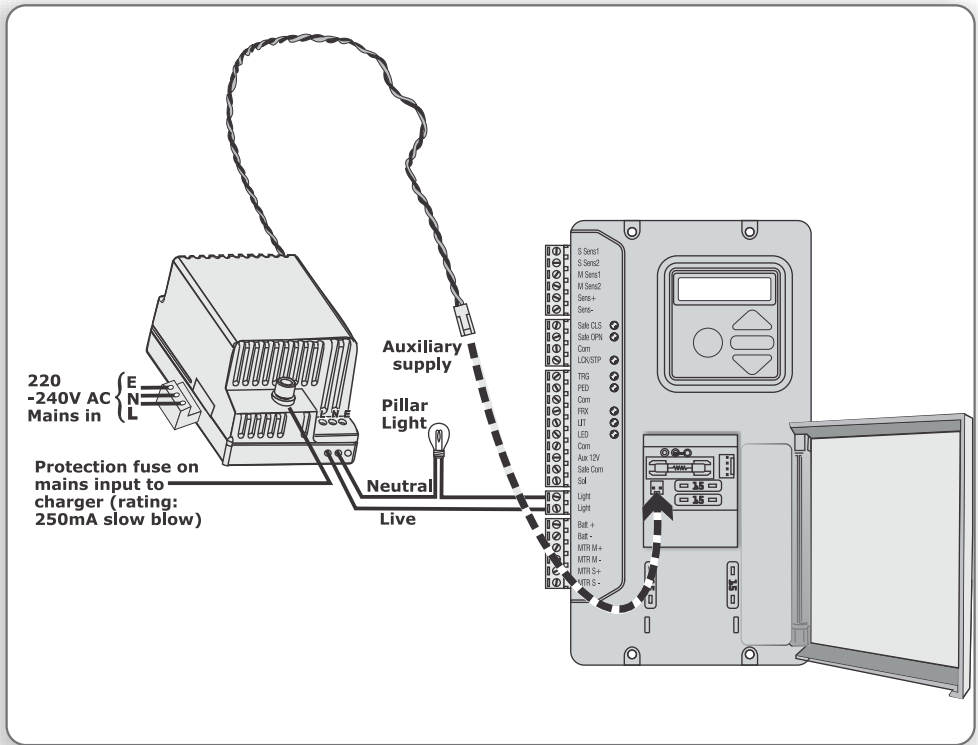

FIGURE 71. CHARGER AND PILLAR LIGHT CONNECTIONS

Fuse protection

The following protection fuses are provided on the system:

Item	Type	Rating
Main controller		
Motor Circuit - fuse per channel	Automotive Fuse (25 x 7)	15A
Light circuit	5 x 20mm	3A Fast Blow
Auxiliary supply	Electronic fuse❖ - not replaceable	3A
CHARGER		
Mains Input	5 x 20mm	250mA Fast Blow

❖ To reset: Power off controller for at least 1 minute and re-apply power

20. Setting up additional features

Figure 68 provides the full menu of features that can be set up on the system. An explanation of each feature is provided in the section 'Controller features'.

When setting up the **VECTOR2** system via the LCD display, all the steps that have to be followed are clearly provided via the display. It is only necessary to note the following:

1. To get into Setup Mode, press the (oblong) button for 3 seconds and follow the instructions provided from there.
2. The buttons provided on the controller for navigating the system, are not marked because at each step during the Setup, the function given to each button is provided on the display.

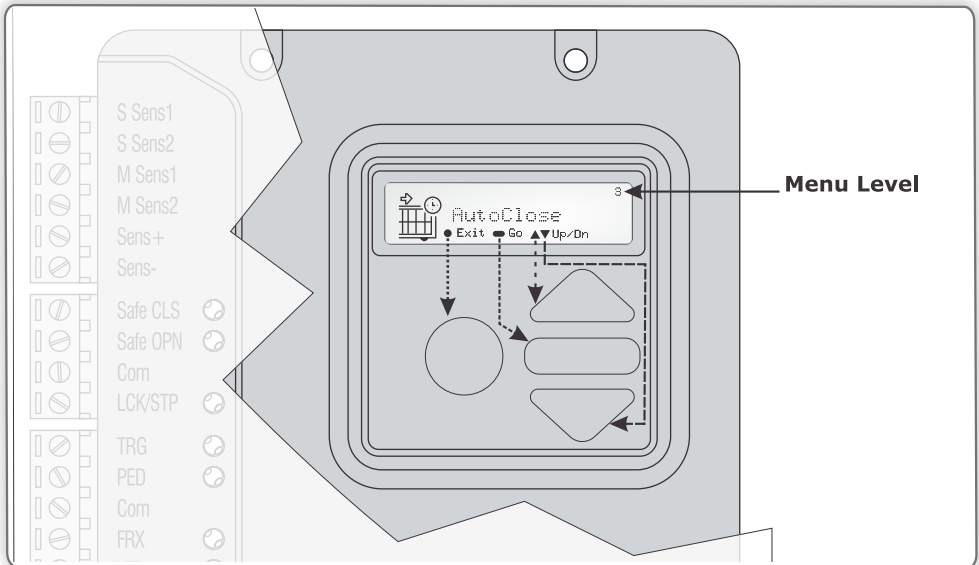

FIGURE 68. VIEW OF CONTROLLER

- 3 **When not in Setup Mode**, ie Normal Mode, the (round) button is used as a TEST button for operating the system. The up/down buttons are not used unless the diagnostic screens have been selected to appear in Normal Mode, in which case these buttons allow switching from one screen to the next.



For each feature a factory default setting has been programmed into the controller. Referred to as an Operating Standard, these defaults have been determined to suit the requirements of the specific region where the installation is being carried out. It is only necessary to change a feature where the default does not suit the installation. When selecting any feature in the menu, details of the current setting stored in the controller are displayed

Refer to Table 1 on page 58 for the Schedule of Factory Defaults for each feature

When the limits are setting (gate opening & Closing) Make sure you see the screen showing the seconds cout it takes to open & shut or the limit switch is not functioning properly

The master gate if you have 2 gates must be wired as the gate that opens first if locking over each other

21. Menu navigation map

Before you set the limits make sure the gate is completely closed using the key



1. Setting limits



1.1. Setup wizard



2. Safety

- 2.1. MTRM Collision Force 2.1.1. MTRM Opening Collision Force
2.1.2. MTRM Closing Collision Force
- 2.2. MTRS Collision Force 2.2.1. MTRS Opening Collision Force
2.2.2. MTRS Closing Collision Force
- 2.3. Collision Count



3. Autoclose

- 3.1. Autoclose status
- 3.2. Autoclose timer
- 3.3. Autoclose override
- 3.4. Autoclose advanced options 3.4.1. Autoclose fully open
3.4.2. Autoclose partly open
3.4.3. Autoclose partly closed

Only set this if it has safety beams fitted and customer wants it



4. Modes of Operation

- 4.1. Operating Mode 4.1.1. Standard Mode ←
- 4.1.2. Condominium Mode
- 4.1.3. Reversing Mode
- 4.1.4. PLC
- 4.1.5. Deadman Control Mode



5. Run profile

- 5.1. Positive Close 5.1.1. Positive Close Status
- 5.1.2. Positive Close Type 5.1.2.1. Short Stop
5.1.2.2. MTRM Only
5.1.2.3. MTRS Only
5.1.2.4. MTRM and MTRS
- 5.1.3. Positive Close Short Stop Value
- 5.1.4. Positive Close Push Force

Set this for Double Gates

Set this for Single Gates to close tight

Set This if required



- 5.2 Leaf delay 2.1.1. Leaf Delay Status
2.2.1. Leaf Delay Value
- 5.2. Pre-open delay
- 5.3. Pre-close delay
- 5.4. Opening speed
- 5.5. Closing speed
- 5.6. Ramp-up distance
- 5.7. Ramp-down distance
- 5.8. TRG stop distance
- 5.9. IRB stop distance
- 5.10. Crawl distance
- 5.11. Torque limit



6. Infrared beams

- 6.1. PIRAC control 6.1.1. PIRAC status
6.1.2. Stop on open 6.1.2.1. Stop on open status
6.1.2.2. Stopping
- 6.2. IR beam test 6.2.1. Status
6.2.2. Test beam
- 6.3. IRBO=IRBC on closing
- 6.4. IR beam alarms..... 6.4.1. Ambush alarm 6.4.1.1. Ambush alarm status
6.4.2. Break-in alarm status 6.4.1.2. Broken IRB time
6.4.3. Alarm output



7. Pedestrian

Set this if customer wants it

- 7.1. Pedestrian open position
- 7.2. Pedestrian Autoclose time
- 7.3. Pedestrian pre-open delay
- 7.4. Pedestrian pre-close delay



8. Gate lock

Check this if it has one

- 8.1. Lock Enabled Status
 - 8.2. Lock Type
 - 8.3. Release Time
 - 8.4. Pre-Release Time
 - 8.5. Lock Location
 - 8.6. Lock Drive (AC/DC)
- Open, Closed or Both**
- Magnet Locks ar DC**



9. Courtesy Light

- 9.1. Courtesy Light timer
- 9.2. Light profile
 - 9.2.1. Courtesy Light
 - 9.2.2. Pre-flash A
 - 9.2.3. Pre-flash B
 - 9.2.4. Pre-flash C



10. Remote controls

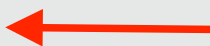

Press button of valid transmitter *(if menu locked)*

- 10.1. Add remotes
- 10.2. Delete remotes
 - 10.2.1.Delete by ID
 - 10.2.2.Delete button
 - 10.2.3.Delete by button
- 10.3. Edit remote button
- 10.4. Autolearn remotes
- 10.5. Tx menu locked
- 10.6. Onboard receiver enable/disable

22. Controller features



Menu 2 - Safety (collision force)

- **Collision force**

If the gate is obstructed, the internal collision circuitry will activate.

The response of the system to a collision will vary, depending on the profile (operating standard, e.g. ZA,) selected. Responses can vary from the gate stopping, to the gate reversing. The collision force can be set from minimum to maximum in five discrete steps.

A sixth step will disable collision sensing entirely, allowing maximum force to be achieved. Under this condition, the motor will continue running until it stalls, at which point a collision will be detected.



This level should only be used if additional safety measures are taken. (e.g. infrared beams, sensitive edge, etc.). Collision force can be set independently per direction of travel

- **Collision count**

A counter monitors the number of collisions that the gate experiences before it reaches the fully closed position. If the value exceeds the value set in the **Multiple Collision Counter** the controller shuts down until the next valid trigger is received. As indication, the **status** LED will flash four times every two seconds. The **Multiple Collision** fault indication will continue to flash indefinitely or until a valid trigger has been received



Menu 3 - Autoclose

- **Autoclose status**

When turned on, the **Autoclose** feature has the function of automatically closing the gate after a preset **Autoclose** time. The **Autoclose** feature is automatically turned on when the controller is set for **Condominium Mode of Operation**

- **Autoclose time**

The **Autoclose** time can be set anywhere from 1 to 255 seconds.

- **Autoclose Override**

It is possible for the user to temporarily turn off **Autoclose** when the Mode of Operation is **Standard** or **Reversing**. To activate **Autoclose Override**, the Trg input must be activated and maintained for a period longer than the time set for the **Autoclose Override Time**.

The gate response will be to start opening on the Trg trigger, and then to stop as soon as the **Autoclose Override** feature is activated. On clearing of the Trg input, the gate will continue opening until fully open. The **Autoclose** feature is now off and the gate will remain open indefinitely.

The next signal received on Trg will clear the **Autoclose Override** feature, close the gate, and set the **Autoclose** feature back to normal.

- **Autoclose Advanced Options**

The conditions under which the gate will automatically close can be set within the **Advanced Autoclose** options menu:

- **Autoclose on open** - automatically close the gate if it has reached the fully open position
- **Autoclose on partly open** - automatically close the gate if it is stopped while opening, but before reaching the fully opened position

- **Autoclose on partly closed** - automatically close the gate if it is stopped while closing, but before reaching the fully closed position



More than one advanced option can be selected



Menu 4 - Modes of Operation

It is possible to select the following Modes of Operation: **Standard, Condominium, Reversing, PLC** and **Deadman Control Mode (DCM)**. All modes are triggered by closing a normally-open contact between the Trg input terminal and the Com terminal.

- **Standard Mode**
When stationary, a trigger impulse on Trg will cause the gate to either open or close. On a moving gate, a trigger impulse on Trg will stop the gate. The next impulse on Trg will cause the gate to reverse its direction of travel, i.e. the action is **start-stop-reverse**.
- **Condominium Mode**
A trigger impulse on Trg will open the gate under all conditions. If it were closing, it will stop and reverse to open. In this Mode of Operation, the only way to close the gate is with the **Autoclose** feature, which is automatically activated when **Condominium** Mode is selected.
- **Reversing Mode**
A trigger impulse on Trg will reverse the direction of a moving gate. If it were closing, it will stop and immediately begin opening. If it were opening, it will stop and immediately begin closing.



Menu 5 - Run Profile

- **Positive Close Mode (PCM)**
Setting **Positive Close Mode** to ON will allow the gate to drive up hard to the closed endstop without causing the collision circuitry to operate. This feature operates only during the last few millimetres of gate travel in closing mode.
- **Positive close type**
 - PCM can be applied to one of the following:
 - Short Stop (further explanation follows)
 - Master motor (MTRM)
 - Slave motor (MTRS)
 - Both Master and Slave motors
- **Short stop**
 - PCM applied to one gate is ideal for securely locking two gates to each other without having to fit endstops. Typically, a 'mechanical' lip is fitted to one gate which will push up against the other gate and via PCM keep pushing until the gates are mechanically locked. To ensure that the gates do not close past their desired end point, the gate (S) against which the gate (M) with the mechanical lip pushes, can be preset to stop slightly short of its closed position. This is referred to as the 'Short Stop' distance. If the 'Short Stop' distance is correctly set, the gate (M) will engage with the S gate sufficiently before the closed position and via the PCM, push the two gates into the fully closed position, but not past.

- **Short Stop value**

The Short Stop distance can be set between 1mm and 40mm of piston stroke

- **PCM push force**

The amount of force applied by the actuator when in PCM can be set as a value from 1 to 15

- **Leaf delay**

Leaf delay is used in cases where one gate leaf must move before the other. The most common need for this arises when a mechanical 'lip' is fitted to one of the gates. In a double leaf installation, a leaf delay can be set whereby the M motor will open before the S motor, and the S motor will close before the M motor

- **Leaf delay value**

The leaf delay is based on piston position, and can be adjusted from 3mm to 250mm of piston travel.

- **Pre-open delay**

Allows a delay between a valid trigger signal being received and the gate commencing movement in the opening direction. A warning light can be set to activate during this delay. (Refer to Pre-flash modes of the feature 'Pillar Light', for more details). This setting applies to both motors

- **Pre-close delay**

Allows a delay between a valid trigger signal being received and the gate commencing movement in the closing direction. The delay will also occur if the gate is set to close automatically. A warning light can be set to activate during this delay. (Refer to Pre-flash modes of the feature 'Pillar Light', for more details). This setting applies to both motors

- **Opening speed**

Sets the maximum piston opening speed in millimeters per second. This setting applies to both motors

- **Closing speed**

Sets the maximum piston closing speed in millimeters per second. This setting applies to both motors

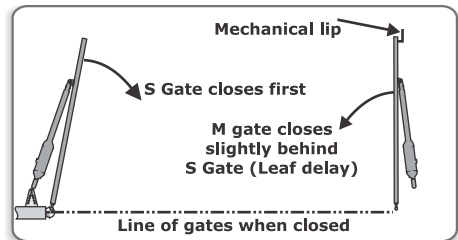

FIGURE 69

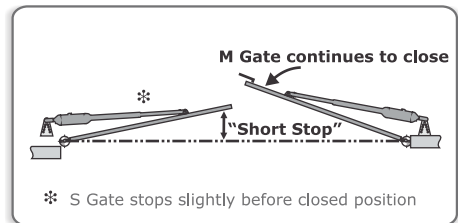

FIGURE 70

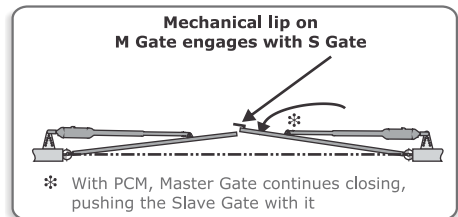

FIGURE 71

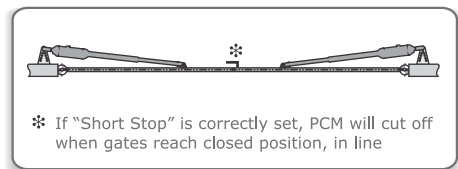

FIGURE 72

- **Ramp-up distance**
Sets the ramp-up distance in millimeters of travel of the piston when starting. This setting applies to both motors
- **Ramp-down distance**
Sets the ramp-down distance in millimeters of travel of the piston when stopping. This setting applies to both motors
- **Crawl distance**
Sets the final crawl distance in millimeters of travel of the piston when reaching an endpoint. This setting applies to both motors
- **Push force limit**
Sets the maximum push force delivered by the motors. The maximum setting is a value of 15 and the minimum is four. This is useful in cases where limited push force is required. This setting applies to both motors



Menu 6 - IR beams

In a swing gate installation, in order to provide protection for a person or vehicle moving through the entrance, it is necessary to have two sets of beams, one across the driveway where the gates are closed and another where the gates are open. Both these beams must be set as closing safety beams, preventing the gate from closing and stop the gates if they have started to close.

However, across the line of the driveway up to where the gates open, it is also recommended to have another set of safety beams to prevent the gate from opening if they are closed and stop if they are opening. Two independent normally-closed inputs are provided for opening and closing safety beams.

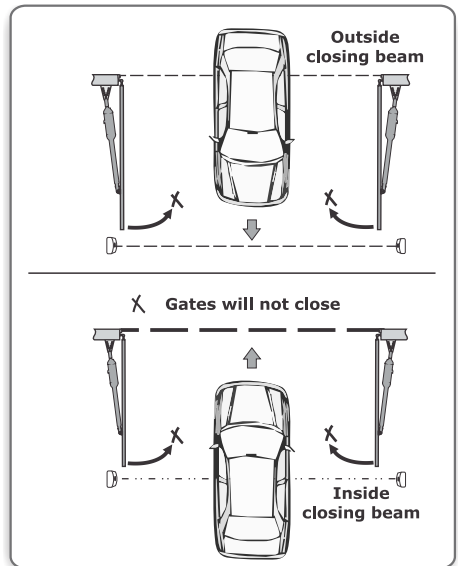

FIGURE 73. TYPICAL CLOSING BEAM INSTALLATION

An interrupted closing beam will prevent the gates from closing and stop and reverse the gates back to the open position if already opening. Vice-versa for a closing beam.

Additional beam functionality is provided:

- **PIRAC**

The **Passive-Infrared Autoclose** feature allows the gate to close automatically, as soon as a vehicle or pedestrian has passed through the closing beam. This security feature ensures that the gate stays open for the minimum amount of time possible.

If the **Autoclose** feature has been enabled, the system will react in the following way:

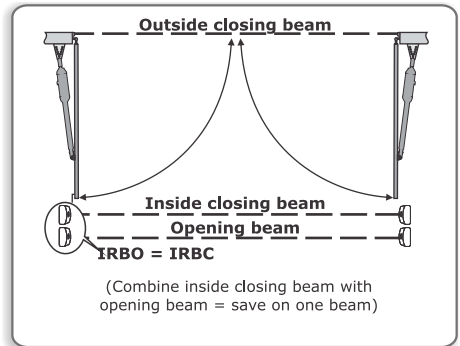

FIGURE 74

- When the gate is triggered to open and nothing moves through or interrupts the closing beam, the gate will open fully and stay open for the period of time determined by the **Autoclose** timer
- However, if the closing beam is interrupted at any stage, while the gate is opening or open, the gate will close immediately after the closing beam is cleared



If the **Autoclose** feature has **not** been enabled then the gate will remain open indefinitely. To close the gate the closing beam must be interrupted or the trigger button must be pressed

- **Safe output status**

Automatically tests the safety beams before each gate cycle. (e.g. as required by CE and UL325)



In order for this feature to work, the power supply negative of the beam transmitter must be wired to the SAF COM terminal of the controller

- The time taken for the gate to open again after it has come to a stop is approximately three seconds

Example:

- **Autoclose override** time set to five seconds: Total time to temporarily disable the PIRAC feature is approximately eight seconds (5s + 3s = 8 seconds)

- **IR beam test**

Automatically tests the safety beams before each gate cycle. (e.g. as required by CE.)

In order for this feature to work, the power supply negative of the beam transmitter must be wired to the safe common terminal of the controller.

- **IRBO=IRBC**

Configures the opening beam to act as a closing beam while the gates are closing. This allows one set of beams to be used across the line of the driveway up to where the gates open.

- **IR beam alarms**

While the gate is fully closed, this feature allows the following alarms:

- **Ambush Alarm**

Activates an alarm if either the opening or closing beams have been continuously interrupted for a predefined time. The alarm will remain activated while the beams are interrupted

For example, if a would-be intruder covers the beams so that when the gate is opened, the gate will stay open, the system will detect this beam override taking place and set off an alarm

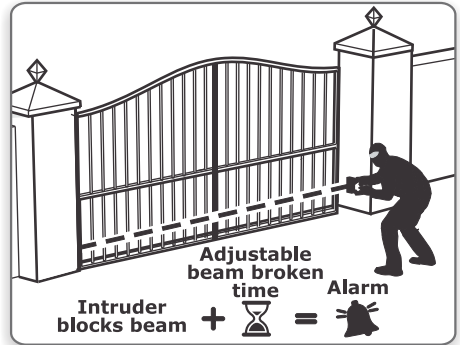

FIGURE 75

- **IR beam broken time**

The time that the beams must be interrupted before the alarm is activated.

- **Break-in Alarm**

Activates an alarm if the closing beam on the outside of the property is interrupted. The alarm remains activated while the beams are broken, and for a period of 30 seconds thereafter. This time is fixed



If this alarm is used, it is recommended that TWO parallel closing beams are used to reduce the chance of false triggering

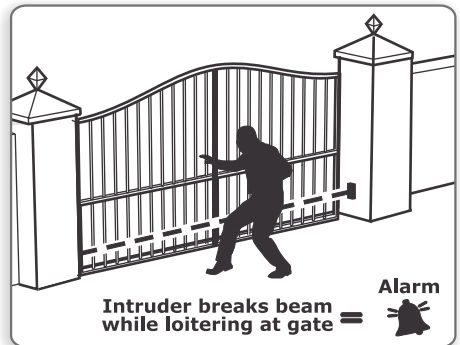

FIGURE 76

- **Alarm output**

The system can be configured to operate one of the following outputs provided on the controller

- **Onboard buzzer** – emits a continuous tone
- **Pillar / Courtesy Light contact** (potential-free normally-open contact, fuse protected – 5A)
- **Aux IO** (this is an open collector drive, maximum current draw 3A, not fuse protected)
- **Safety beam common** (this is an open collector drive, maximum current draw 3A, not fuse protected)
- **Status LED output** (operate up to three LEDs in parallel or interface with multi- LED driver card, CP78)



Menu 7 - Pedestrian Opening

This feature is associated with the Ped input on the controller. When activating this input, the system will open the gate to the pedestrian open position, and then automatically close after the Pedestrian Autoclose time lapses. If the Ped connection to Com is maintained, then the gate will remain open, and when the connection is broken, it will close after the Pedestrian Autoclose time has expired

The time taken for the gate to open to pedestrian is dependent on the pedestrian pre-open delay and the time required for the gate to close from the pedestrian position is dependent on the pedestrian pre-close delay

- **Pedestrian Open Position**

Sets the maximum opening of the pedestrian gate in metres, in one centimetre steps

- **Pedestrian Autoclose Time**

Sets the Autoclose time in seconds after a Pedestrian Opening. This time can be set from zero seconds to four minutes in one second steps.

- **Pedestrian Pre-open Delay**

Sets the time delay between the pedestrian input being activated, and the gate actually opening. This enhances safety in cases where the pedestrian has to reach through the gate in order to activate the pedestrian input. A warning light* would typically be active during this delay. This delay can be set from zero seconds to four minutes in one second steps

- **Pedestrian Pre-close Delay**

Sets the time delay between the Pedestrian Autoclose timer expiring, and the gate actually closing. A warning light* would typically be active during this delay. This delay can be set from zero seconds to four minutes in one second steps



* The warning light is any light wired to the Pillar Light contacts, as described in Menu 9



Menu 8 - Gate lock

An electric strike lock or magnetic lock can be connected to the control card, allowing the gate to be locked when closed, open or both.

- **Lock enable status**

Turns the lock functionality on or off

- **Lock type**

Allows selection of either a solenoid strike lock, or a magnetic lock. A solenoid strike unlocks when power is applied, while a magnetic lock unlocks when power is removed

- **Release time**

Sets the time period (in seconds) for which the lock remains released after the gate has started moving

- **Pre-release time**

Sets the time period (in 0.1s increments) for which the lock releases BEFORE the gate has started moving. This is useful in cases where premature gate movement prevents the lock from releasing

- **Lock location**

Specifies whether the gate is locked while closed, open or both

- **Lock drive**

Specifies if the lock is to be powered by an AC or DC voltage. Selecting AC will power the lock with a 50Hz square wave



Menu 9 - Courtesy/Pillar Light

This feature is associated with the **Light** connections on the controller. Refer to Section 16 of the manual for details on how to connect a pillar or security light to the controller

The Pillar Light circuit has multiple functions:

- It operates as a Courtesy Light and switches on for a selectable time period every time the gate is activated
- The Courtesy Light can also be turned on for the same time period by momentarily connecting the Aux terminal to the Com terminal via a pushbutton
- The Courtesy Light can also be turned on permanently by connecting the Aux terminal to the Com terminal via a pushbutton, for three seconds. A short pulse thereafter will switch the lights off. The status LED will flash once every two seconds to indicate that the Courtesy Light is on permanently. The above-mentioned facility can also be achieved via a remote learned to the system and mapped to the Courtesy Light function from within the remotes menu



The gate will not open when using the **Aux** trigger input

- When the Ped input is triggered, the Courtesy Light flashes for an adjustable (1 to 255 seconds) pre-flash time, before the pedestrian gate opens
- **Courtesy Light time**
The time that the Courtesy Light will remain activated can be set from four seconds to ten hours in one second increments
- **Light profile**
 - The Courtesy Light can be selected to operate according to one of the following:
 - **Courtesy Light** as explained earlier
 - **Pre-flashing Mode**
 - If Pre-flashing Mode A, B or C is selected, the behaviour of the Courtesy Light will be as follows:
 - **Mode A** will turn on the Courtesy Light only while the gate is moving
 - **Mode B** will flash the Courtesy Light during the pre-opening and pre-closing delays, as well as while the gate is moving

- **Mode C** will turn on the Courtesy Light during the pre-opening and pre-closing delays, as well as while the gate is moving
- In these pre-flashing modes, the timed Courtesy Light functionality is not available



Menu 10 - General features

- **Operating standard**

Regional operating standards can be set. Applying this setting will automatically configure the controller settings to conform to the specific region's standard (e.g. UL325 or CE)

- **Reset options**

The controller settings can be reset through the **reset options** menu. Various reset options are available:

- **Factory defaults** – All settings will be restored to the default values dictated by the Operating Standard/Profile that is currently selected. All remote controls and gate limits will not be affected
- **Delete all remotes** - Delete all the remotes stored in the system, no settings affected
- **Reset all** – Clears and defaults the system completely. Unit will be reset to the factory default settings in addition to clearing all remotes and time periods

- **Diagnostic screen**

Allows a diagnostic screen to be displayed. This can be useful when troubleshooting, but requires some technical knowledge

- **Round test button**

Allows the round test button on the controller to be disabled, in cases where higher security is required



Menu 11 - Remote controls

The controller is capable of learning up to 64 CENTSYS NOVA remote controls / transmitters. Each transmitter can have up to four buttons. Each transmitter learned into the system is assigned a unique transmitter ID

- It is possible to artificially increase the number of buttons of a multi-button transmitter by using a two button combination
- One of the buttons is used as a **shift button** to allow the other buttons to be used again in combination with this button. In other words the user will press and hold the shift button, before pressing one of the other buttons to create a **new** button
- The shift button cannot be used as a button on its own, it must always be used in combination with the other buttons



Benefits of the shift button system:

- Use of the **shift button system** allows a three button transmitter to gain an extra button and operate four functions and likewise a four button transmitter gains two extra buttons and can operate six functions





- Another benefit of using the shift button system is that **it requires both hands to operate the two button combination**. This prevents the user from accidentally enabling sensitive functions such as Holiday Lockout on the controller
- Each transmitter learned into the system is assigned a unique transmitter ID
- **Press valid button**
If the **remote controls menu** has been locked as discussed later, only by pressing a button of a transmitter learned into the system, can the **remote controls menu** be accessed
- **Add remote**
Any button can be set to control the Trigger, Pedestrian, Free-exit, Holiday Lockout or Courtesy Light Control (Aux) inputs. When adding transmitters, it is recommended that a record be kept of the ID number allocated by the system to each respective transmitter and the person to whom the transmitter is given. This is necessary should selective deletion be required at a later stage
- **Delete remote**
Transmitters can be deleted at any stage according to one of the following methods:
 - **Delete remote by ID**
Each transmitter can be deleted individually according to its unique ID. To facilitate this, a record of the ID and the person to whom the ID has been assigned must have been made at the time of learning the transmitter into the system. The transmitter is not required for this operation
 - **Delete remote button**
The operation of a button of a particular transmitter can be cleared. For example, it allows the **Holiday Lockout** function set on one remote button of a transmitter to be cleared, without affecting the other operations that the same transmitter performs. The transmitter is required for this operation
 - **Delete remote by button**
Use this procedure to remove the transmitter from the system. All button functionality will be removed. The transmitter is required for this operation
- **Delete all remotes**
Clears the entire memory. All transmitters will be removed
- **Edit remote button**
Change the function of one button to perform another function. For example, button one's function is to open the gate completely. To change this, use the **edit remote button**, select Ped, and button one of the same remote will now only open the gate to pedestrian
- **Transmitter menu locked**
Allows the **remote controls menu** to be locked, preventing the unauthorized addition of new transmitters to the system. Once enabled, the **remote controls menu** can only be accessed by pressing a valid transmitter button

23. Factory defaults schedule

South African standard profile - ZA

Parameter Description	Unit	Minimum	Default	Maximum
Autoclose Enabled	Yes/No		No	
Autoclose from Fully Open	Yes/No		Yes	
Autoclose from Partly Open	Yes/No		Yes	
Autoclose from Partly Closed	Yes/No		No	
Autoclose Time	Mm:ss	00:00*	0:15	04:00*
Autoclose Override Time	S	2*	3	15*
Mode of Operation	S,R,C		Standard	
Motor M Opening Force	Level	1	3	Max (6)
Motor M Closing Force	Level	1	3	Max (6)
Motor S Opening Force	Level	1	3	Max (6)
Motor S Closing Force	Level	1	3	Max (6)
Max. No. Collisions	Collisions	1	4	255
Collision Alarm Output	B,C,P,S,L		Buzzer	
PCM Enabled	Yes/No	No	No	Yes
PCM Type	M,S,M & S,SS		Master only	
PCM Stop Short Distance	mm	1	5	40
PCM Force	%(A)	1	3	15
Leaf Delay Enabled	Yes/No	No	No	Yes
Leaf Delay	Mm	3*	10*	250*
Opening Speed	Mm/s	10	30	Max
Closing Speed	Mm/s	10	30	Max
Ramp-up Distance	Mm	20	30	400
Ramp-down Distance	Mm	20	30	400
Crawl Distance	Mm	5	10	400
Torque Limit	(A)	4	11	15
Pre-Open Delay Time	S	0	0	196
Pre-Close Delay Time	S	0	0	196

* Settings are fixed across standards

** Settings are not configurable via the GUI

South African standard profile - ZA (continued)

Parameter Description	Unit	Minimum	Default	Maximum
PED Open Distance	% (Full Open)	10	30	100
PED Autoclose Time	S	0	5	240
PED Pre-Open Delay Time	S	0	2	240
PED Pre-Close Delay Time	S	0	0	240
Gate Lock Enabled	Yes/No		No	
Gate Lock Type	M,S		Striker	
Gate Lock Pre-Release Time	S	0.1*	0.0 24.0*	24.0*
Gate Lock Release Time	S	0.1*	1.0*	24.0*
Gate Lock Location	C,O,C & O		Close Only	
Gate Lock Drive Type	AC,DC		AC	
Courtesy Light Time	H:mm:ss	0:00:04*	0:02:00	9:59:59*
Courtesy Light Profile	Crt,A,B,C		Courtesy	
PIRAC Enabled	Yes/No	No	No	Yes
SAF Common Enabled	Yes/No	No	No	Yes
SAF Common Tests which Beams	C,O,C & O		IRBC Only	
IRBO acts as IRBC	Yes/No	No	No	Yes
IRB Ambush Alarm Enabled	Yes/No	No	Yes	Yes
RB Ambush Alarm Hold-Off Time	Minutes	1	1	225
IRB Break-In Alarm Enabled	Yes/No	No	No	Yes
IRB Alarms Output	B,C,P,S,L		Buzzer	
Diagnostic Screen Enabled	Yes/No		No	
Test Push-Button Enabled	Yes/No		Yes	
Remote Menu Locked	Yes/No		No	
Helix Mode Disabled**	Yes/No		Yes	
IRBO Starts Wire-Less**	Yes/No		Yes	
IRBC Starts Wire-Less**	Yes/No		Yes	
LCK Starts Wire-Less**	Yes/No		Yes	

* Settings are fixed across standards

** Settings are not configurable via the GUI

CE standard profile

Parameter Description	Unit	Minimum	Default	Maximum
Autoclose Enabled	Yes/No		No	
Autoclose From Fully Open	Yes/No		Yes	
Autoclose From Partly Open	Yes/No		Yes	
Autoclose From Partly Closed	Yes/No		No	
Autoclose Time	Mm:ss	00:00*	00:15	04:00*
Autoclose Override Time	S	2*	3	15*
Mode Of Operation	S,R,C		Standard	
Motor M Opening Force	Level	1	3	Max (6)
Motor M Closing Force	Level	1	3	Max (6)
Motor S Opening Force	Level	1	3	Max (6)
Motor S Closing Force	Level	1	3	Max (6)
Max. No. Collisions	Collisions	1	4	255
Collision Alarm Output	B,C,P,S,L		Buzzer	
PCM Enabled	Yes/No	No	No	Yes
PCM Type	M,S,M&S,SS		Master Only	
PCM Stop Short Distance	Mm	1	10	40
PCM Force	% (A)	1	3	15
Leaf Delay Enabled	Yes/No	No	No	Yes
Leaf Delay	(Mm)	3*	10*	250*
Opening Speed	Mm/s	10	30	30
Closing Speed	Mm/s	10	30	30
Ramp Up Distance	Mm	20	30	400
Ramp Down Distance	Mm	20	30	400
Crawl Distance	Mm	5	5	400
Torque Limit	(A)	4	11	15
Pre-Open Delay Time	S	0	0	196
Pre-Close Delay Time	S	0	0	196

* Settings are fixed across standards

** Settings are not configurable via the GUI

CE standard profile (continued)

Parameter Description	Unit	Minimum	Default	Maximum
PED Open Distance	% (Full Open)	10	50	100
PED Autoclose Time	S	0	5	240
PED Pre-Open Delay Time	S	0	2	240
PED Pre-Close Delay Time	S	0	0	240
Gate Lock Enabled	Yes/No		No	
Gate Lock Type	M,S		Maglock	
Gate Lock Pre-Release Time	S	0.0**	0.0	24.0**
Gate Lock Release Time	S	0.1*	1.0	24.0*
Gate Lock Location	C,O,C&O		Close Only	
Gate Lock Drive Type	AC,DC		DC	
Courtesy Light Time	H:mm:ss	0:00:04*	00:02:00	9:59:59*
Courtesy Light Profile	Crt,A,B,C		PFA	
PIRAC Enabled	Yes/No	No	No	Yes
SAF Common Enabled	Yes/No	Yes	Yes	Yes
SAF Common Tests which Beams	C,O,C&O		IRBC Only	Yes
IRBO acts as IRBC	Yes/No	No	No	
IRB Ambush Alarm Enabled	Yes/No	No	No	Yes
IRB Ambush Alarm Holdoff Time	Minutes	1	1	255
IRB Break-In Alarm Enabled	Yes/No	No	No	Yes
IRB Alarms Output	B,C,P,S,L		Buzzer	
Diagnostic Screen Enabled	Yes/No		No	
Test Push-Button Enabled	Yes/No		Yes	
Remote Menu Locked	Yes/No		No	
Helix Mode Disabled**	Yes/No		Yes	
IRBO Starts Wire-Less**	Yes/No		Yes	
IRBC Starts Wire-Less**	Yes/No		Yes	
LCK Starts Wire-Less**	Yes/No		Yes	

* Settings are fixed across standards

** Settings are not configurable via the GUI

UL325 standard profile

Parameter Description	Unit	Minimum	Default	Maximum
Autoclose Enabled	Yes/No		No	
Autoclose From Fully Open	Yes/No		Yes	
Autoclose From Partly Open	Yes/No		Yes	
Autoclose From Partly Closed	Yes/No		No	
Autoclose Time	Mm:ss	00:00*	00:15	04:00*
Autoclose Override Time	S	2*	3	15*
Mode Of Operation	S,R,C		Standard	
Motor M Opening Force	Level	1	3	Max (6)
Motor M Closing Force	Level	1	3	Max (6)
Motor S Opening Force	Level	1	3	Max (6)
Motor S Closing Force	Level	1	3	Max (6)
Max. No. Collisions	Collisions	1	2	2
Collision Alarm Output	B,C,P,S,L		Buzzer	
PCM Enabled	Yes/No	No	No	Yes
PCM Type	M,S,M&S,SS		Master Only	
PCM Stop Short Distance	Mm	1	10	40
PCM Force	% (A)	1	3	15
Leaf Delay Enabled	Yes/No	No	No	Yes
Leaf Delay	(Mm)	3*	10*	250*
Opening Speed	Mm/s	10	30	30
Closing Speed	Mm/s	10	30	30
Ramp Up Distance	Mm	20	30	400
Ramp Down Distance	Mm	20	30	400
Crawl Distance	Mm	5	5	400
Torque Limit	(A)	4	11	15
Pre-Open Delay Time	S	0	0	196
Pre-Close Delay Time	S	0	0	196

* Settings are fixed across standards

** Settings are not configurable via the GUI



UL325 standard profile (continued)

Parameter Description	Unit	Minimum	Default	Maximum
PED Open Distance	% (Full Open)	10	50	100
PED Autoclose Time	S	0	5	240
PED Pre-Open Delay Time	S	0	2	240
PED Pre-Close Delay Time	S	0	0	240
Gate Lock Enabled	Yes/No		NO	
Gate Lock Type	M,S		Maglock	
Gate Lock Pre-Release Time	S	0.0*	0.0	24.0*
Gate Lock Release Time	S	0.1*	1.0	24.0*
Gate Lock Location	C,O,C&O		Close Only	
Gate Lock Drive Type	AC,DC		DC	
Courtesy Light Time	H:mm:ss	0:00:04*	0:02:00	9:59:59*
Courtesy Light Profile	Crt,A,B,C		Courtesy	
PIRAC Enabled	Yes/No	No	No	Yes
SAF Common Enabled	Yes/No	No	No	Yes
SAF Common Tests which Beams	C,O,C&O		IRBC Only	
IRBO acts as IRBC	Yes/No	No	No	Yes
IRB Ambush Alarm Enabled	Yes/No	No	No	Yes
IRB Ambush Alarm Holdoff Time	Minutes	1	1	255
IRB Break-In Alarm Enabled	Yes/No	No	No	Yes
IRB Alarms Output	B,C,P,S,L		Buzzer	
Diagnostic Screen Enabled	Yes/No		No	
Test Push-Button Enabled	Yes/No		Yes	
Remote Menu Locked	Yes/No		No	
Helix Mode Disabled**	Yes/No		Yes	
IRBO Starts Wire-Less**	Yes/No		Yes	
IRBC Starts Wire-Less**	Yes/No		Yes	
LCK Starts Wire-Less**	Yes/No		Yes	

* Settings are fixed across standards

** Settings are not configurable via the GUI

24. Description of terminal functions

S Sens1	Motor S (MTR S) operator. Connects to the thin PURPLE wire of the Motor S operator.
S Sens2	Motor S (MTR S) operator. Connects to the thin BLUE or ORANGE wire of the Motor S operator.
M Sens1	Motor M (MTR M) operator. Connects to the thin PURPLE wire of the Motor M operator.
M Sens2	Motor M (MTR M) operator. Connects to the thin BLUE or ORANGE wire of the Motor M operator.
Sens +	Operator sensor power connection. A 5V output for connecting to the thin RED sensor wire on both the MTR M and MTR S operators.
Sens -	Operator sensor power connection. A 0V output for connecting to the thin BLACK or GREY sensor wire on both the MTR M and MTR S operators.
Safe CLS	<p>CLOSING edge safety input. (A normally-closed potential-free input). For as long as a connection between this input and COM is maintained the controller will behave normally. When this connection is broken it will prevent the gate from closing if it is stationary, and will stop and reverse the gate if it is closing. This input has no effect if the gate is opening.</p>  <p>(If the Saf CLS function is not required a link must be fitted between Safe CLS and COM for the controller to operate normally.*)</p>
Safe OPN	<p>OPENING edge safety input. (A normally-closed potential-free input). For as long as a connection between this input and COM is maintained the controller will behave normally. When this connection is broken it will prevent the gate from opening if it is stationary, and will stop and reverse the gate if it is opening. This input has no effect if the gate is closing.</p>  <p>(If the Safe OPEN and reverse functions are not required a link must be fitted between safe OPEN and COM for the controller to operate normally.*)</p> <p>When setting up the controller for the first time or after a full reset back to factory default has been performed, the system will electronically override the Safety Inputs and allow the system to function without the links. However if safeties are connected to either or both inputs, thereafter there must be a normally-closed circuit maintained for the system to operate correctly. I.e. if beams are fitted and then removed, the circuit which is affected must be replaced with a wire link to create the normally closed circuit</p> <p>*</p>
LCK/STP	<p>Holiday Lockout or gate STOP input. (A normally-closed potential-free input). For as long as a connection between this input and COM is maintained the controller will behave normally. But, when this connection to COM is broken all inputs are inhibited, and if the gate is moving it will stop.</p>  <p>(If the LCK function is not required a link must be fitted between LCK and COM.)</p>

TRG	Trigger input. (A normally-open potential-free input) Momentarily connecting this input to COM will cause the gate to open or close depending on the operating mode selected. For more information see the Autoclose feature and Modes of Operation
PED	Pedestrian opening input. (A normally-open potential-free input). Momentarily connecting this input to COM will cause one gate to open to the Pedestrian open position. For more information refer to the Pedestrian feature
FRX	Free-exit input. (A normally-open potential-free input). Momentarily connecting this input to COM will cause a gate which is closed, or closing, to open or re-open. If the gate is open, or opening, the signal has no effect other than to reset the Autoclose timer (if selected). Free-exit (FRX) never initiates a closing cycle. The only way to close a gate, if only the FRX input is used, is to activate the Autoclose feature on the controller
LIT	LIT Activates the Pillar Light output. (A normally-open potential-free input). Momentarily connecting this input to COM will cause the LIGHT relay to energize for a period of time as set in the Courtesy Light Timer menu. If the connection is made for a period exceeding 3 seconds the Pillar Light Relay will latch and remain latched indefinitely until a new momentary connection to COM is given.
LED	External gate status indicator. (A low current output signal.) An output terminal which provides a low current drive (approx. 4,5V DC, 20mA) to a LED which can be used to indicate the gate status remotely. If more than three LEDs are required it is necessary to fit the CP78 MULTI LED driver card. For more details on the feedback about the status of the gate provided by the STATUS LED refer to page 64
Com	The COMMON termination point. All trigger signals etc. have their return path to one of the COM terminals.
Aux 12V	Auxiliary power connection. Provides a +12V DC supply for auxiliary equipment such as a radio receiver, photo cells, etc. It is linked directly to the battery positive via a 3A resettable fuse.
Safe Com	Used for switching the power supply to the safety beams. If automatic beam testing is required, the negative power supply connection of the beam transmitters and receivers must be wired to this point
Sol	Solenoid strike or Magnetic lock. A solenoid strike lock or Magnetic lock can be connected between 12V and SOL. Note that the maximum current draw allowed for the lock is 2A. Should the solenoid lock or magnetic lock exceed this current rating it is necessary to use an interposing relay
	Particularly with magnetic locks, ensure that the steady state current draw calculated over a 24 hour period and added to this, the quiescent current draw of the controller, other peripherals and the usage of the motors, does not exceed the current delivered by the charger. If necessary, fit a separate supply to power the lock using an interposing relay connected to the Sol input.

Light	Pillar Light connection. These two terminals provide a normally-open potential-free contact which is generally used to switch on a Pillar Light (Courtesy Light). This contact is fuse protected – refer to page 41 for fuse specifications.
Batt +	Positive battery connection. (Battery terminal normally indicated as + or RED)
Batt -	Negative battery connection. (Battery terminal normally indicated as - or BLACK)
MTR M+	Motor M operator power connection. (Thick BLUE wire).
MTR -	Motor M operator power connection. (Thick BLACK wire).
MTR S+	Motor S operator power connection. (Thick BLUE wire).
MTR S-	Motor S operator power connection. (Thick BLACK wire).

25. Diagnostics

Diagnostic LEDs

The controller is fitted with diagnostic lights (LEDs) that assist with the setup and maintenance of the gate.

Figure 74 below provides a description and purpose of the indicator lights also indicating the location on the controller

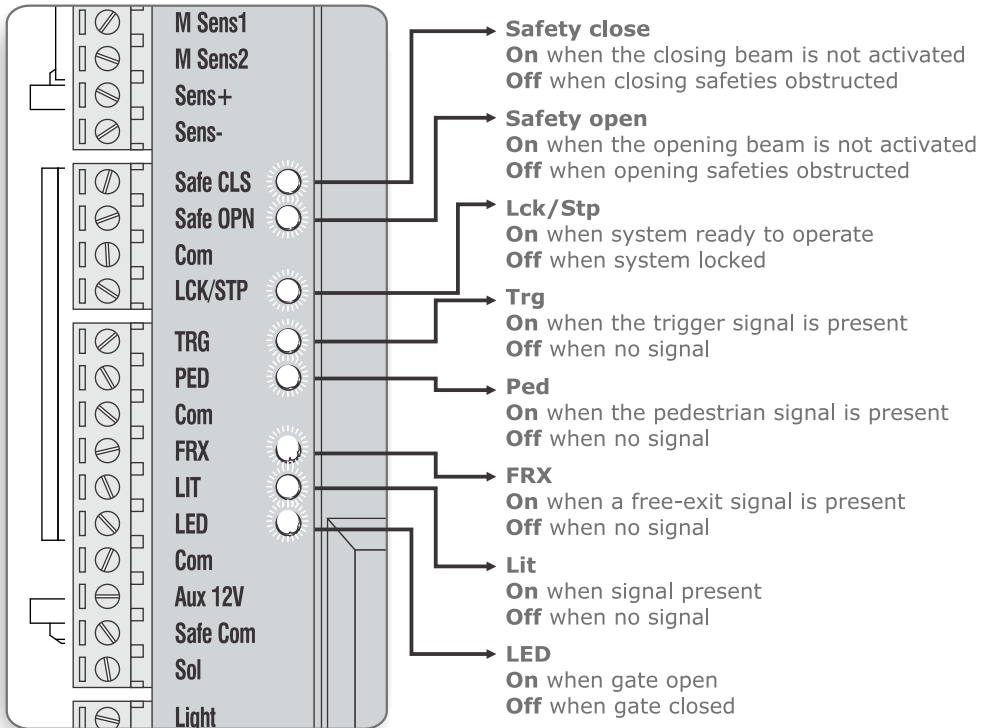

FIGURE 74

Gate status LED

Slow regular flash	Gate is opening
Fast regular flash	Gate is closing
One flash every two seconds	Courtesy Light latched on
Two flashes every two seconds	Mains Failure
Three flashes every two seconds	Battery Low
Four flashes every two seconds	Collision Shutdown
Four flashes every two seconds	Multiple Collisions have occurred

LCD display

The LCD display shows useful information regarding the status of the system.

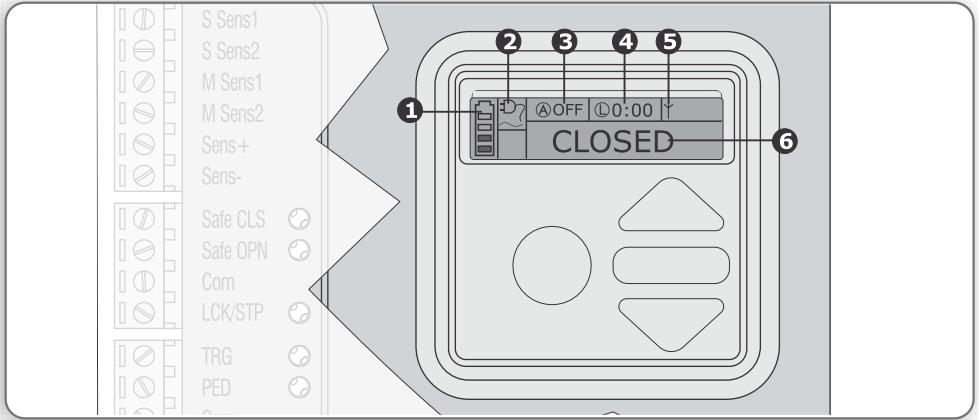

FIGURE 75. CONTROLLER SCREEN

1. Battery icon

Indicates the state of charge of the battery.

- Four solid bars = full capacity
- Two solid bars = 50% capacity
- No solid bars, with the icon flashing = battery empty

2. Mains icon

Displays the presence/absence of mains voltage:

- Plug solid = mains present and battery charging
- Plug hollow and flashing = No mains present and battery not charging

3. Autoclose information

- Displays the state of the Autoclose function
- Displays off if Autoclose is not selected
- OVR if Autoclose is overridden, and the remaining Autoclose time if Autoclose is active
- POVR indicates that the PIRAC option is overridden

4. Pillar Light information

- Displays the remaining light time if Courtesy Light Mode is selected
- Pre-flashing mode is displayed if pre-flash is selected
- LIT will be indicated if the Pillar Light has been turned on permanently

5. Onboard receiver information

Displays the current input being activated by the onboard receiver.

6. Status information

Displays useful information regarding the status of the gate.

Buzzer feedback

The **VECTOR2** controller is equipped with an onboard buzzer which is used for various features and functions on the controller. One of the functions it provides is audible diagnostic feedback as detailed

Inhibitor name	Priority	Number of beeps	Fault type	Gate continues to operate	User can correct error
Break-in alarm	1	Continuous tone for 30 seconds	Alarm	N/A	N/A
Ambush alarm	2	Continuous tone until IRBs are cleared	Alarm	N/A	N/A
Battery low	3	3 beeps periodically for 30 seconds	Power system fault	Yes*	Yes
Multiple collision	4	Periodic until condition is cleared by user (500/500ms)	Collision	No	Yes
Auxiliary overload	5	5 beeps periodically for 30 seconds	Hardware	No	No
Holiday Lockout	6	1 beep periodically for 30 seconds	User	No	Yes
Emergency stop	7	1 beep periodically for 30 seconds	User	No	Yes
Time-barring	8	1 beep periodically for 5 seconds	User	No	Yes
No limits set	9	3 short beeps for 5 seconds	Lost	No	Yes
Mains failure	10	2 beeps periodically for 30 seconds	Power system fault	Yes	Yes
Beams broken (any)	11	1 beep periodically for 30 seconds	User	No	Yes
Beams failure	12	5 beeps periodically for 30 seconds	Hardware	No	No
DOSS disconnected	13	5 beeps periodically for 30 seconds	Hardware	No	No
Fuse blown	14	5 beeps periodically for 30 seconds	Hardware	No	Yes
Motor disconnected	15	5 beeps periodically for 30 seconds	Hardware	No	Yes
Bridge damaged	16	5 beeps periodically for 30 seconds	Hardware	No	No
Gate stalled	17	4 beeps periodically for 10 seconds	Collision	No	Yes

* Gate will close fully and then shutdown for two minutes

26. Installation handover

Once the installation has been successfully completed and tested, it is important for the installer to explain the operation and safety requirements of the system.

NEVER ASSUME THE USER KNOWS HOW TO SAFELY OPERATE AN AUTOMATED GATE!

Even if the user has used one before, it does not mean he knows how to SAFELY operate it. Make sure that the user fully understands the following safety requirements before finally handing over the site.

The following needs to be understood by the user:

- How to operate the manual release mechanism. **(Show them how by demonstration)**
- How the obstruction detection and all other safety features work. **(Show them how by demonstration)**
- All the features and benefits of the operator, i.e. Safety beams, etc.
- **All the safety considerations associated with operating an automated gate. The user should be able to pass this knowledge on to all other users of the automated system and must be made aware of this responsibility.**



- **Do not activate the gate operator unless you can see it and can determine that its area of travel is clear of people, pets, or other obstructions**
- **NO ONE MAY CROSS THE PATH OF A MOVING GATE. Always keep people and objects away from the gate and its area of travel**
- **NEVER LET CHILDREN OPERATE OR PLAY WITH THE GATE CONTROLS, and do not allow children or pets near the gate area**
- **Be careful with moving parts and avoid close proximity to areas where fingers or hands could be pinched**
- **Secure all easily accessed gate operator controls in order to prevent unauthorized use of the gate**
- **Keep the automated gate system properly maintained, and ensure that all working areas are free of debris and other objects that could affect the gate operation and safety**
- **On a monthly basis, check the obstruction detection system and safety devices for correct operation**
- **All repair and service work to this product must be done by a suitably qualified person**

This product was designed and built strictly for the use indicated in this documentation. Any other use, not expressly indicated here, could compromise the good condition/operation of the product and/or be a source of danger!



Centurion Systems (Pty) Ltd does not accept any liability caused by improper use, of the product, or for use other than that for which the automated system was designed.

Ensure that the customer is in possession of the User Guide and that you have completed the installation details in the back of the User Guide.



Head Office: +27 11 699 2400

Technical Support: +27 11 699 2481
from 07h00 to 18h00 (GMT+2)



0.07.B.0045

www.centsys.com.au