



ROTARY SWING GATE OPERATOR

Company Profile

Centurion Systems (Pty) Ltd, South Africa, has been manufacturing automatic gate systems since 1986, and is committed to providing reliable, cost effective solutions in the field of gate and access automation.

We offer a diverse range of products including gate motors, GSM-based products, garage door motors, remote controls, keypads, traffic barriers, proximity access control and intercom systems.

Our products are developed by an in-house team of talented engineers that are constantly researching new and innovative technologies to improve our existing products and expand our product range.

Our production facility in Johannesburg is ISO:9001 quality assurance certified, and all our products are manufactured to the highest level of quality with a 100% test to specification.

Through a team of dedicated technicians and sales personnel, together with a fully fledged in-house training facility, we are committed to providing unmatched service to our customers and support for our products.

A worldwide network of distributors and installers ensure that our products remain The Automatic Choice in access automation .

Further information is available on our website www.centsys.com.au



Centurion Systems (Pty) Ltd reserves the right to make changes to the products described in this document without notice and without obligation of Centurion Systems (Pty) Ltd to notify any persons of any such revisions or changes. Additionally, Centurion Systems (Pty) Ltd makes no representations or warranties with respect to this document.

No part of this document may be copied, stored in a retrieval system or transmitted in any form or by any means electronic, mechanical, optical or photographic, without the express prior written consent of Centurion Systems (Pty) Ltd.

Table of Contents

Declaration of Conformity	4
Important Safety Instructions	5
Fast Track	6
General Description	8
Specifications	8
Product Identification	10
Required Tools & Equipment	12
Site Considerations	13
Cabling Requirements	14
Operator Installation	15
Pedestal Mount Features	15
Wall Mount Features	15
Locate the Operator Position	15
Where to Position the Operator	16
Mount Gate Bracket	22
Route Cables & Secure Motor Mounting	22
Fasten Gearbox in Position	23
Determine Drive Arm Length	23
Fit the Drive Arm	24
Set the Connecting Arm	24
Electrical Setup	27
Connect all Wiring	27
Set Up the Gate Origin/s	27
Get into Programming Mode	28
Select either Master or Slave Motor Setup	29
Set the Gate Limits	29
Setting Additional Features (Optional)	30
Controller Features	32
Set-Up Troubleshooting Guide	35
Fault Finding Guide	37
Procedure to Programme Controller Back to Factory Default Settings	43
Manual Release Mechanism	43
Normal Operation	43
Determine Gate Swing Angle	44
Description of Terminal Function	45
LED Indicator Lights	46
CP75 Controller Functions	47
CP75 Controller Connections	48
CP75 Trigger Connections	49
CP84ER5V01 Charger Connection	50
PSUx Power Connection	50
Installation Handover	51

Declaration of Conformity

Manufacturer: Centurion Systems (Pty) Ltd
Unit 13 Northlands Production Park Epsom Avenue
Northriding Randburg Johannesburg 2196

Declares that the product:

Product Name: R3/R5 Swing Gate Operator
Product Options: All variants

Conforms with the following specifications:

Safety: IEC 60355-1:1991 & Am1:1994 & Am2:1999

Emissions: CISPR 22 CLASS B: RADIATED EMISSIONS - 30MHZ TO 1000MHZ
CISPR 22 CLASS B: CONDUCTED EMISSIONS - 150MHZ TO 30MHZ

Immunity: IEC 61000-4-2 - ELECTROSTATIC DISCHARGE
IEC 61000-4-3 - RADIATED IMMUNITY - 80MHZ TO 1000MHZ
IEC 61000-4-4 - ELECTRICAL FAST TRANSIENTS / BURST
IEC 61000-4-5 - SURGE IMMUNITY TEST
IEC 61000-4-6 - CONDUCTED IMMUNITY - 150KHZ TO 80MHZ
IEC 61000-4-11 - VOLTAGE DIPS AND INTERRUPTION

Standard to which conformity is declared:

IEC 60355-1:1991 & Am1: 1994 & Am2: 1999
IEC 1000-6-3 & IEC 1000-6-1: Generic Emission and Immunity

Signed at North Riding, South Africa on March 24, 2004



Ian Rozowsky
Research & Development Director

Important Safety Instructions

⚠ ATTENTION

To ensure the safety of people, it is important that you read all the following instructions. Incorrect installation or incorrect use of the product could cause serious harm to people.

The installer, being either professional or DIY, is the last person on the site that can ensure that the operator is safely installed, and that the whole system can be operated safely.

WARNINGS FOR THE INSTALLER

1. CAREFULLY READ AND FOLLOW ALL INSTRUCTIONS before beginning to install the product.
2. This appliance is not intended for use by persons (including children) with reduced physical, sensory or mental capabilities, or lack of experience and knowledge, unless they have been given supervision or instruction concerning use of the appliance* by a person responsible for their safety.
3. All installation, repair, and service work to this product must be done by a suitably qualified person.
4. Do not activate your gate opener unless you can see it and can determine that its area of travel is clear of people, pets, or other obstructions.
5. NO ONE MAY CROSS THE PATH OF A MOVING GATE. Always keep people and objects away from the gate and its area of travel.
6. NEVER LET CHILDREN OPERATE OR PLAY WITH THE GATE CONTROLS, and do not allow children or pets near the gate area.
7. Secure all easily accessed gate opener controls in order to prevent unauthorized use of the gate.
8. Do not in any way modify the components of the automated system.
9. Do not install the equipment in an explosive atmosphere: the presence of inflammable gas or fumes is a serious danger to safety.
10. Before attempting any work on the system, cut electrical power and disconnect the batteries.
11. The mains power supply of the automated system must be fitted with an all-pole switch with contact opening distance of 3mm or greater. Use of a 5A thermal breaker with all-pole circuit break is recommended.
12. Make sure that an earth leakage circuit breaker with a threshold of 30mA is fitted upstream of the system.
13. Never short circuit the battery and do not try to recharge the batteries with power supply units other than that supplied with the product, or by Centurion Systems (Pty) Ltd.
14. Make sure that the earthing system is correctly constructed, and that all metal parts of the system are suitably earthed.
15. Safety devices must be fitted to the installation to guard against mechanical movement risks such as crushing, dragging and shearing.
16. It is recommended that at least one warning indicator light be fitted to every system.
17. Always fit the warning signs visibly to the inside and outside of the gate.
18. The installer must explain and demonstrate the manual operation of the gate in case of an emergency, and must hand the User/Warnings guide over to the user.
19. Explain these safety instructions to all persons authorized to use this gate, and be sure that they understand the hazards associated with automated gates.
20. Do not leave packing materials (plastic, polystyrene, etc.) within reach of children as such materials are potential sources of danger.
21. Dispose of all waste products like packaging materials, worn out batteries, etc, according to local regulations.
22. **Always check** the obstruction detection system, and safety devices for correct operation.
23. Centurion Systems (Pty) Ltd does not accept any liability caused by improper use of the product, or for use other than that for which the automated system was intended.
24. This product was designed and built strictly for the use indicated in this documentation. Any other use, not expressly indicated here, could compromise the good condition/operation of the product and/or be a source of

* Appliance should be product described in manual

⚠ WARNING



MOVING GATE CAN CAUSE SERIOUS INJURY OR DEATH

KEEP CLEAR. GATE MAY MOVE AT ANY TIME. DO NOT ALLOW CHILDREN TO PLAY IN AREA OR OPERATE GATE .

These abbreviated instructions are for the experienced installer who needs a checklist to get a standard installation up and running in the minimum of time.

Detailed installation features and functions are referred to later in this manual.

Mechanical Setup

<i>Action</i>		
Step 1	Read and understand all safety instructions	Page 5
Step 2	Gather required tools and equipment.	Page 12
Step 3	Heed necessary site considerations.	Page 13
Step 4	Check cabling requirements.	Page 14
Step 5	Select appropriate mounting configuration	Page 15
Step 6	Mount the gate bracket in position.	Page 22
Step 7	Route cables & secure motor mounting	Page 22
Step 8	Fasten gearbox in position	Page 23
Step 9	Determine drive arm length	Page 23
Step 10	Fit drive arm	Page 24
Step 11	Set connecting arm	Page 24

Electrical Setup

<i>Action</i>		
Step 1	Read and understand all safety instructions	Page 5
Step 2	Connect all wiring:	Page 27
Step 3	Set the gate origin: <ul style="list-style-type: none">• Release the manual override and close the gate(s)• Use origin tool and line up marks• Open gate 1/2 way and unscrew the manual release mechanism.	Page 27
Step 4	Get into programming mode: <ul style="list-style-type: none">• Remove all power.• Fit the SET link.• Reapply power.	Page 28
Step 5	Select master or slave set-up: <ul style="list-style-type: none">• Press and hold TEST, release after 1 flash of L1.• Press and hold TEST, release after 1 or 2 flashes (1=master, 2=slave).	Page 29
Step 6	Set the gate limits: <ul style="list-style-type: none">• Press and hold TEST until gate is closed, release.• Press and hold TEST until gate is open, release.• Press and release TEST. (The MASTER gate will close and open to pedestrian. The SLAVE gate will close slightly).	Page 29
Step 7	Set additional features: (If required)	Page 30
Step 8	Exit programming mode: <ul style="list-style-type: none">• Remove the SET link.	
Step 9	Perform installation hand over	Page 51

General Description

The R3 & R5 rotary swing gate systems are designed to open and close swing gates. The CP75 controller is capable of handling both single and double swing gates and offers many features to suit almost any application.

Detailed specifications for the R3 & R5 motors are shown in the figure below and the table alongside.

The unit employs a battery driven DC motor for low duty domestic applications, which provides automatic backup protection in the event of a power failure. The unit can also be fitted with a high duty power supply in addition to the battery to allow for more frequent operation of the gate.

The R3 & R5 operators are fitted with an internal electronic limit switch system, which provides reliable and accurate positioning of the gate. This system allows the operator to smoothly slow the gate down at the fully open or closed positions.

A fail-safe and highly reliable collision sensing system is built into the controller, which will cause the motor to stop while the gate is opening, and stop and reverse when closing if a gate is obstructed in any way. (The collision sensitivity will be reduced during the endpoints of sinusoidal motion).

Gate movement is transmitted to the gate by means of articulated arms. The length of both the drive arm and the connecting arm is easily adjusted to give maximum installation flexibility.

Specifications

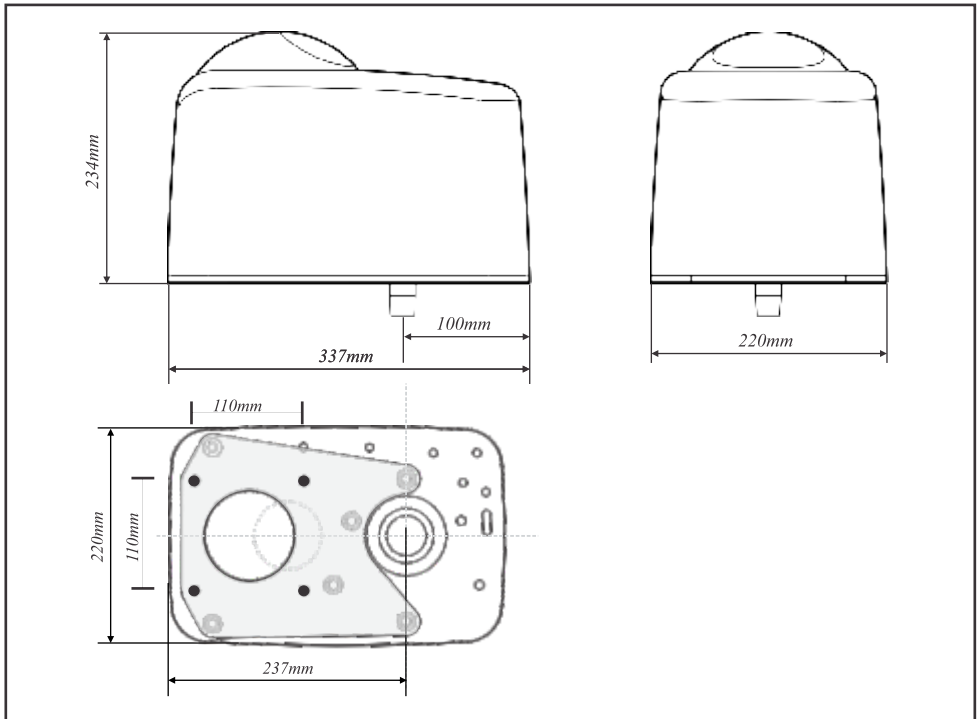

Figure 1 Overall Dimensions

SPECIFICATION	R3	R5
Input Voltage*	220V AC \pm 10% 50Hz	220V AC \pm 10% 50Hz
AC Current draw (with C84E Battery Charger)	120mA	120mA
DC Motor Voltage	12V	12V
DC Current draw (Max)	30A	35A
Maximum solenoid lock current draw	2A	2A
Output shaft rotational speed	3.5 rpm	2.6 rpm
Maximum output torque	95Nm	250Nm
Mass of master motor kit (excluding pedestal or wall bracket)	14.4kg	15,5kg
Mass of slave motor kit (excluding pedestal or wall bracket)	12.9kg	14,0kg
Maximum number of operations per day (Average):		
Light industrial, with 10A power pack (PSU)	100	250
Domestic, with 1A Battery Charger (CP84E)	20	20
Maximum number of continuous operations	20	100
Typical time to open/close a gate (For standard pedestal in recommended position)	10 seconds	13 seconds
No. of operations on a 7A/H battery (should the mains power fail)	\pm 20	\pm 20
Limit switches	Sealed optical counter with origin switch	Sealed optical counter with origin switch
Collision sensitivity	Electronic adjustable	Electronic adjustable
Temperature range	-20° to +50°C	-20° to +50°C
Housing protection	IP55	IP55
Control card (single or double motor)	CP75	CP75
Corrosion protection (baseplate and arms)	Zinc passivation with lacquer impregnation	Zinc passivation with lacquer impregnation

*Other voltages are available

SPECIFICATION (continued)

Maximum gate length & mass for Installation:

Standard Inward Opening or Limited Space Installation

Maximum wind speeds for which the operator will open the gate:

Gate Length:	1,5m	2,0m	2,5m	3,0m [▲]	3,5m [▲]
R3 - Max. Allowable Leaf Mass:	400kg	400kg	320kg	225kg	160kg
R3: For a 1,8m high gate, 25% coverage#:	75km/h	54km/h	44km/h	38km/h	34km/h
R3: For a 1,8m high gate, 100% coverage#:	37km/h	27km/h	22km/h	19km/h	17km/h

R5 - Max. Allowable Leaf Mass:	600kg	600kg	510kg	360kg	260kg
R5: For a 1,8m high gate, 25% coverage#:	127km/h	93km/h	74km/h	64km/h	56km/h
R5: For a 1,8m high gate, 100% coverage#:	64km/h	46km/h	37km/h	32km/h	28km/h

Perpendicular or Parallel Wall Mount & Outward Opening

Maximum wind speed for which the operator will open the gate

Gate Length:	1,5m	2,0m
R3 - Max. Allowable Leaf Mass:	400kg	300kg
R3: For a 1,8m high gate, 25% coverage#:	50km/h	34km/h
R3: For a 1,8m high gate, 100% coverage#:	25km/h	17km/h

R5 - Max Allowable Leaf Mass:	600kg	600kg
R5: For a 1,8m high gate, 25% coverage#:	89km/h	63km/h
R5: For a 1,8m high gate, 100% coverage#:	44km/h	31km/h

[▲] -Electric lock recommended; # -When installed in recommended positions, and collision sensitivity set to LOW.

Product Identification

The actual components supplied may vary depending on the model purchased.

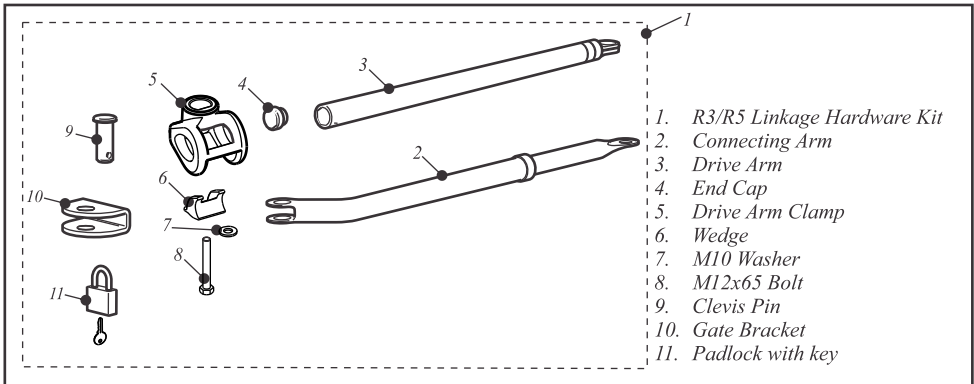
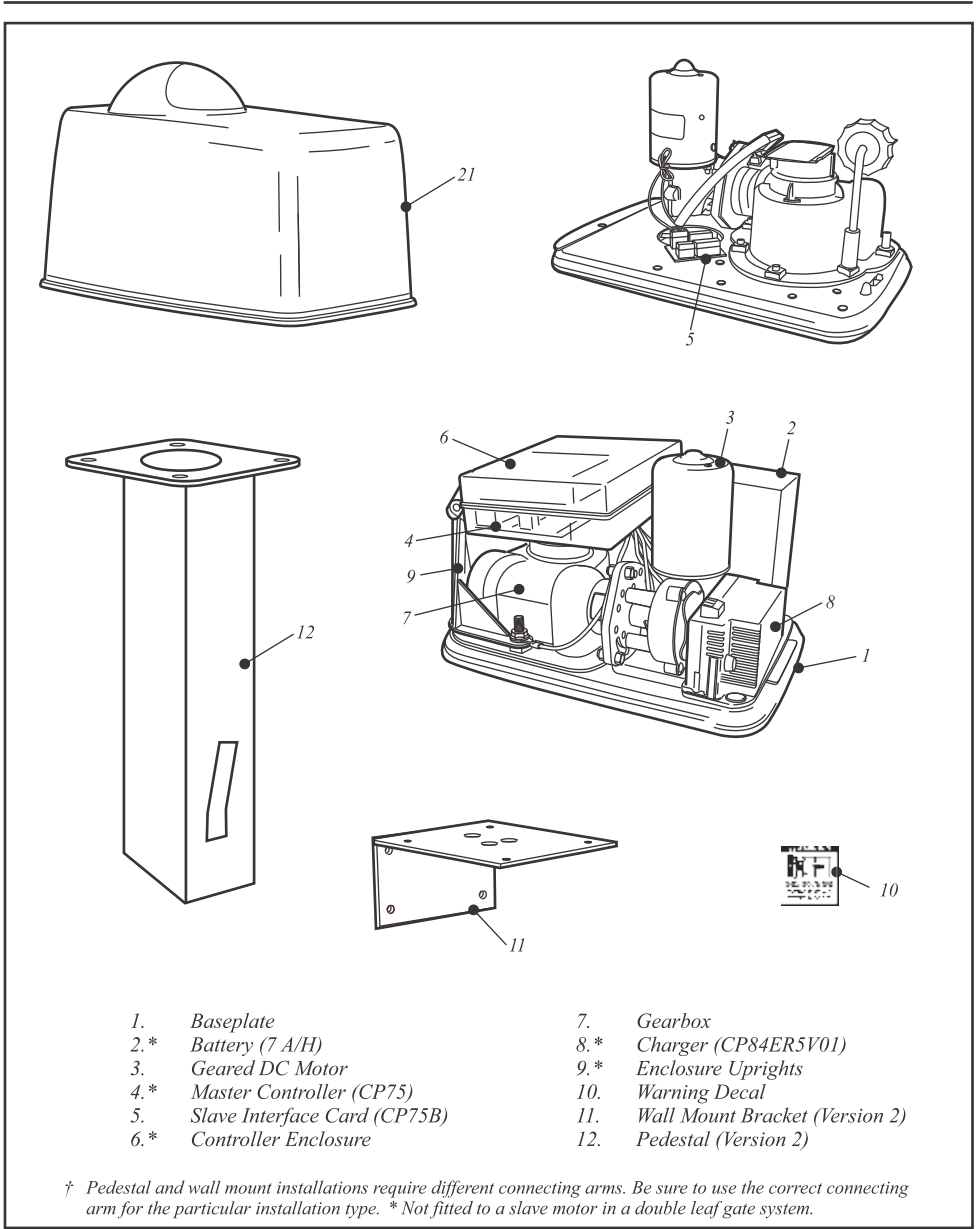

Figure 2 Linkage Hardware Kit



- | | | | |
|-----|------------------------------|-----|--------------------------------|
| 1. | Baseplate | 7. | Gearbox |
| 2.* | Battery (7 A/H) | 8.* | Charger (CP84ER5V01) |
| 3. | Geared DC Motor | 9.* | Enclosure Uprights |
| 4.* | Master Controller (CP75) | 10. | Warning Decal |
| 5. | Slave Interface Card (CP75B) | 11. | Wall Mount Bracket (Version 2) |
| 6.* | Controller Enclosure | 12. | Pedestal (Version 2) |

† Pedestal and wall mount installations require different connecting arms. Be sure to use the correct connecting arm for the particular installation type. * Not fitted to a slave motor in a double leaf gate system.

Figure 3 Product Identification

Required Tools & Equipment

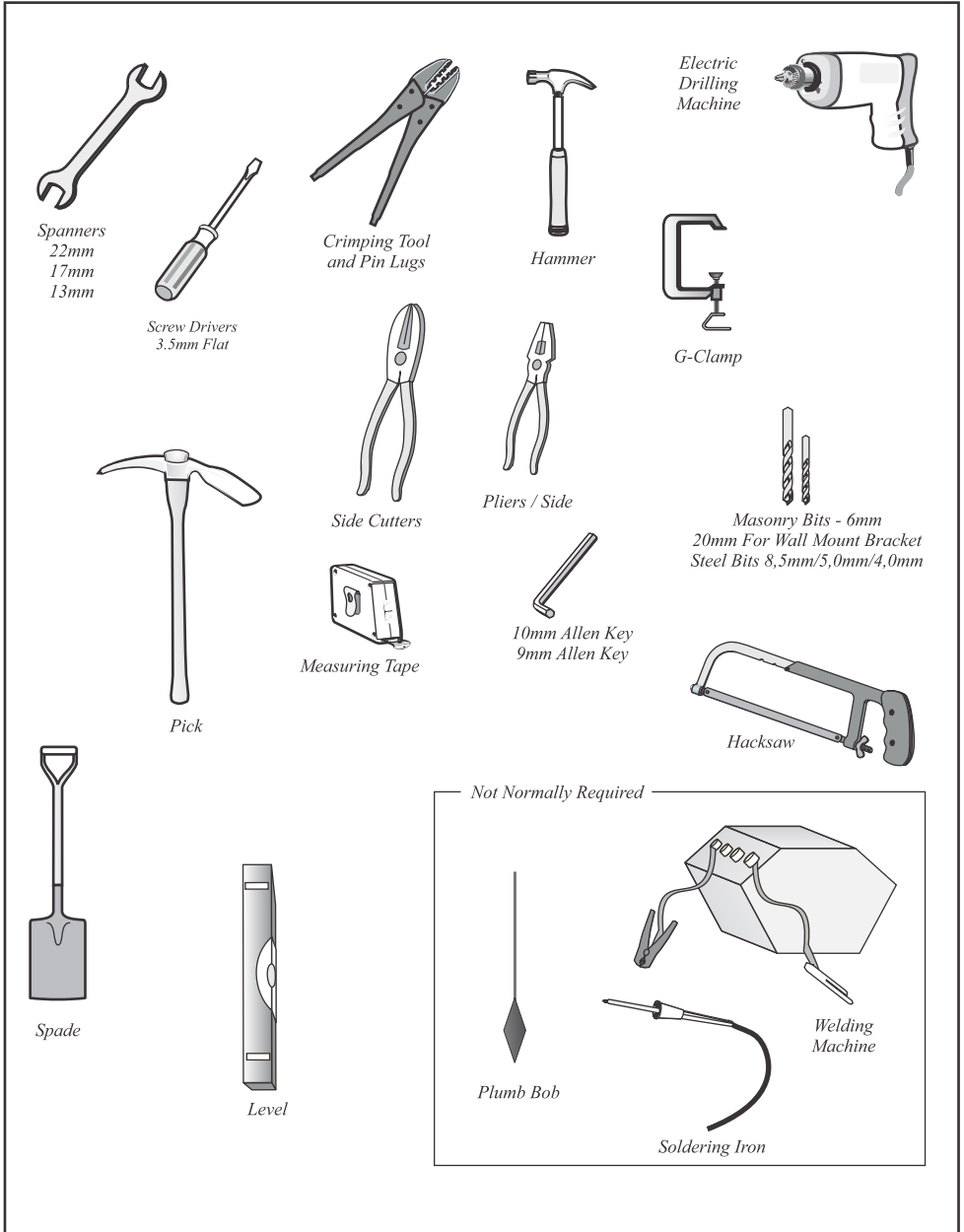

Figure 4 Required Tools and Equipment

Site Considerations

Install the gate operator only if:

1. It will not pose a hazard to the public.
2. There is sufficient clearance to a roadway and/or public thoroughfares.
3. The installation will meet all municipal and/or local authority requirements once completed.
4. The gate mass, length and application is within the operator specifications (see page 9).
5. The gate is in good working order, meaning:
 - That it moves freely.
 - Does not move on its own if left in any position.
6. It can be installed to have sufficient clearance between moving parts when opening and closing to reduce the risk of personal injury and entrapment.
7. Pushbuttons or key switches, when required, can be positioned so that the gate is in line of sight of the operator.

General considerations for the installation:

1. Always recommend the fitment of additional safety equipment such as safety edges and safety beams, for additional protection against entrapment or other mechanical risks.
2. Check that there is enough ground clearance below the motor to enable assembly of the drive arm clamps (see page 21).
3. Check that no pipes or electrical cables are in the way of the intended installation.
4. Check that enough space is available for the gate operator with the gate in the required open position.
5. Check for loose sandy soil if installing foundations, as the soil condition may require a larger foundation.
6. Check the strength of the mounting pillar in the case of a wall mount installation.
7. If the swing gate leaf is longer than 2.5m for a wall mount installation, or 3.5m for pedestal-mount installations, ensure that a lock can be fitted.
8. Never fit the operator on the outside of the gate, where the public has access to it. (Follow the instructions for an outward opening swing gate, if required.)

Operator Installation

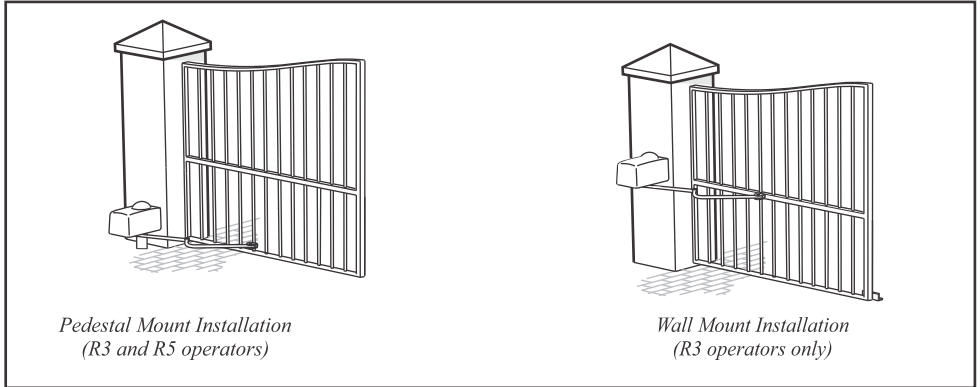

Figure 6 Basic Installation Options

Pedestal Mount Features

- Secure locking with no need for gate end stops.
- Can be used on both inward and outward opening gates and on installations where space is limited.
- Provides the smoothest gate motion.
- Provides very secure locking and high security.
- Where a gate leaf width exceeds 3.0m a gate lock is recommended for security.
- Installation is independent of the size and strength of gate pillar.

Products required per gate leaf automation:

- 1 x R3 or R5 operator.
- 1 x R3 or R5 long linkage hardware kit (which includes drive arm, connecting arm, fasteners and bracket).
- 1 x Pedestal.

NOTE: Ensure that you use a LONG connecting arm for this type of installation.

Wall Mount Features

- Very compact installation.
- Requires a pillar strong enough to support the operator and potential loading if the gate is forced.
- Where a gate leaf width exceeds 2.5m a gate lock is recommended for optimum security.
- The operator may be mounted parallel or perpendicular to the pillar, whichever is best suited for the installation.
- Perpendicular installations are recommended since it inherently provides better locking and greater security.

Products required per gate leaf automation:

- 1 x R3 or R5 operator.
- 1 x R3 or R5 long linkage hardware kit (which includes drive arm, connecting arm, fasteners and bracket)
- 1 x Wall mount bracket.

NOTE: Ensure that you use a SHORT connecting arm for this type of installation.

Locate the Operator Position

1. Swing the gate to the required open position and estimate the swing angle of the gate using the angle diagrams in Fig.7 to 11. Alternatively determine the gate swing angle by following the procedure detailed on page 44.

Where to Position the Operator

PEDESTAL POSITIONING FOR STANDARD INSTALLATION (SMOOTHEST MOVEMENT, BEST LOCKING)

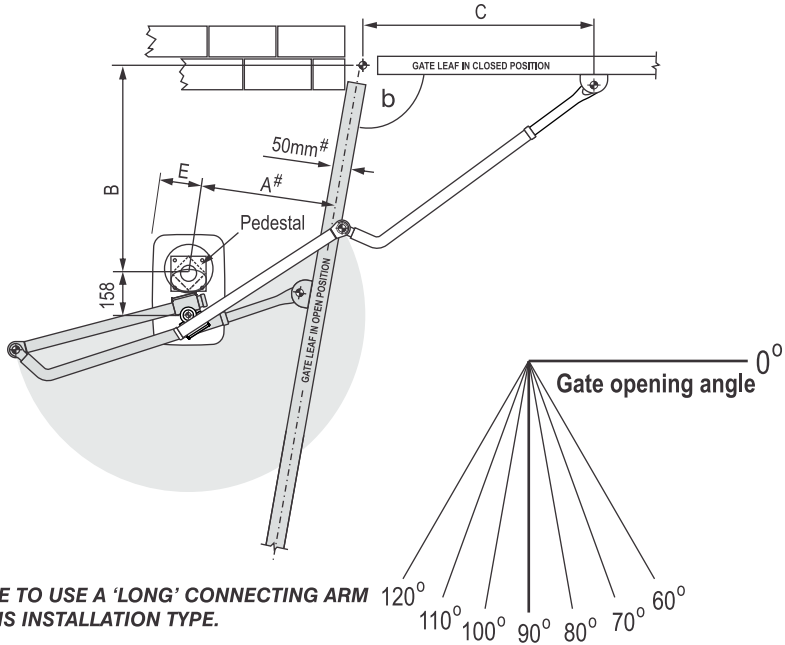

BE SURE TO USE A 'LONG' CONNECTING ARM FOR THIS INSTALLATION TYPE.

b Gate Opening Angle (Degrees)	A# Gate Centre to Pedestal Centre	B Hinge Centre to Pedestal Centre	C Hinge Centre to Gate Bracket	E Pedestal to edge of motor
60	350 to 610 (370)	550 to 790 (750)	650 to 700 (700)	224
70	320 to 600 (340)	550 to 790 (750)	650 to 700 (700)	191
80	240 to 530 (260)	550 to 790 (750)	650 to 700 (700)	153
90	200 to 450 (220)	550 to 740 (700)	650 to 700 (700)	110
100	210 to 400 (230)	500 to 740 (700)	600 to 650 (650)	122
110	250 to 440 (330)	450 to 640 (600)	500 to 610 (610)	130
120	280 to 440 (300)	300 to 490 (450)	500 to 570 (570)	130

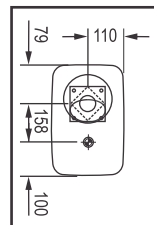

- Ensure that the gate does not exceed the relevant specifications on page 9.
- Recommended values are shown in bold type.
- All dimensions shown are indicated in millimetres.
- All recommended values will result in gates with similar opening times.

© Centurion Systems (Pty) Ltd

Figure 7 Pedestal Positioning for Standard Installations

PEDESTAL POSITIONING FOR INSTALLATIONS WITH LIMITED SPACE

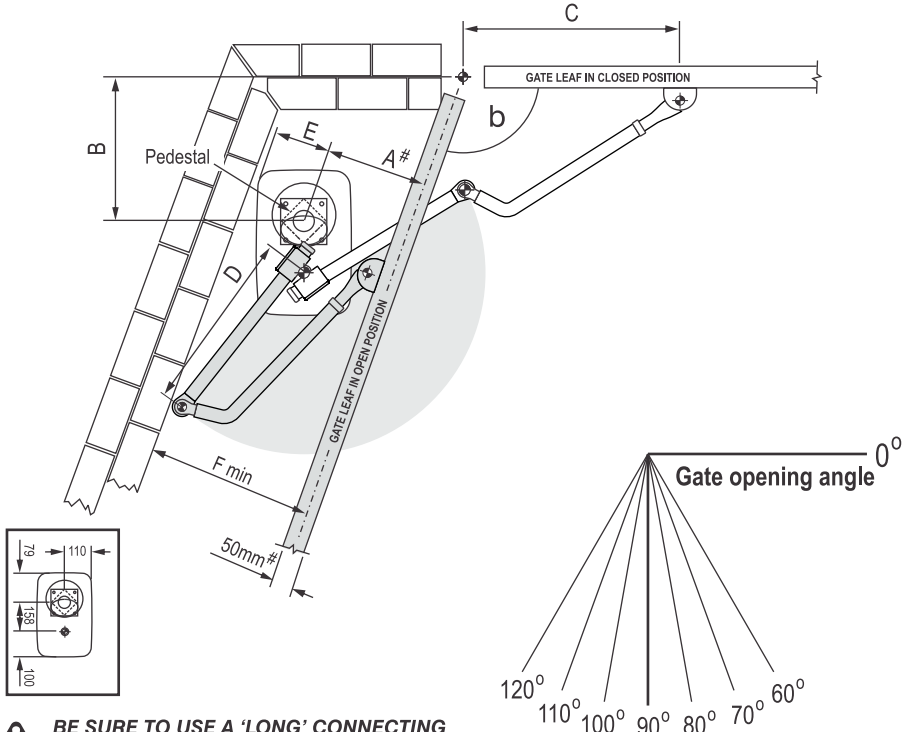

! BE SURE TO USE A 'LONG' CONNECTING ARM FOR THIS INSTALLATION TYPE.

b	A#	B	C	D	E	F
Gate Opening Angle (Degrees)	Gate Centre to Pedestal Centre	Hinge Centre to Pedestal Centre	Hinge Centre to Gate Bracket	Drive Arm Length	Edge of Motor to Pedestal Centre	Gate Centre to Wall
60	190 to 390 (190)	800 to 890 (850)	800 (800)	475 (419)	224	414
70	190 to 380 (190)	750 to 890 (850)	700 to 750 (750)	500 (444)	191	381
80	180 to 370 (180)	750 to 840 (800)	650 to 700 (700)	500 (461)	153	333
90	170 to 360 (170)	700 to 840 (800)	600 to 650 (650)	500 (459)	110	280
100	210 to 400 (210)	550 to 840 (800)	550 to 610 (610)	500 (464)	122	332
110	250 to 440 (250)	450 to 640 (600)	500 to 590 (590)	500 (487)	130	380
120	280 to 420 (280)	350 to 540 (500)	500 to 570 (570)	500 (496)	130	410

- Ensure that the gate does not exceed the relevant specifications on page 9.
- Recommended values are shown in bold type.
- All dimensions shown are indicated in millimetres.
- All recommended values will result in gates with similar opening times.

© Centurion Systems (Pty) Ltd

Figure 8 Pedestal Positioning for Installations with Limited Space

PEDESTAL POSITIONING FOR OUTWARD OPENING GATES

It is recommended to fit end stops in the open position of the gate to reduce gate movement when open.

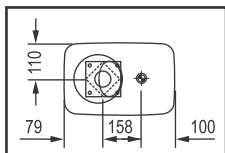
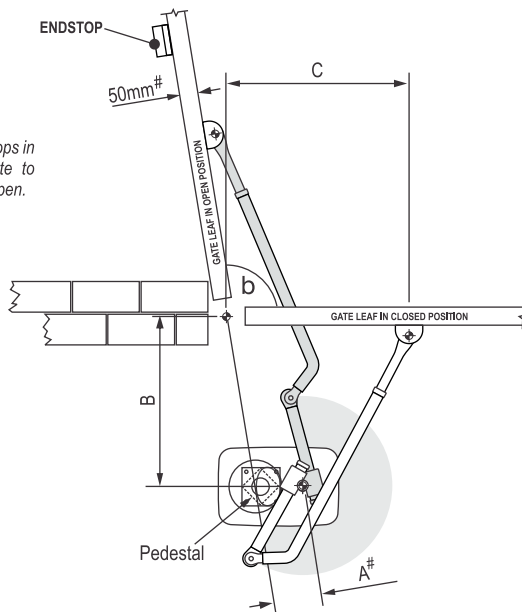

BE SURE TO USE A 'LONG' CONNECTING ARM FOR THIS INSTALLATION TYPE.

b	A#	B	C
Gate Opening Angle (Degrees)	Gate Edge or Hinge Point to Shaft Centre	Hinge Centre to Shaft Centre	Hinge Centre to Gate Bracket
60	240 to 530 (250)	600 to 660 (640)	500 (500)
70	150 to 440 (160)	580 to 640 (620)	500(500)
80	100 to 400 (120)	560 to 660 (580)	500 to 550 (550)
90	100 to 400 (120)	520 to 640 (580)	550 to 600 (600)
100	100 to 400 (120)	440 to 660 (580)	550 to 600 (600)
110	100 to 380 (120)	360 to 620 (400)	550 to 600 (600)
120	100 to 260 (120)	340 to 580 (480)	550 to 650 (650)

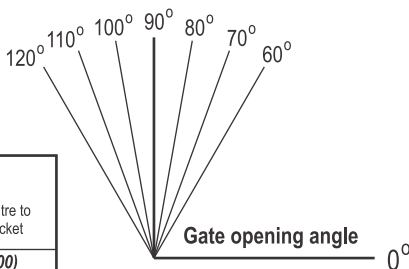

- Ensure that the gate does not exceed the relevant specifications on page 9.
- Recommended values are shown in bold type.
- All dimensions shown are indicated in millimetres.
- All recommended values will result in gates with similar opening times.

PERPENDICULAR WALL MOUNT

**FOR INSTALLATIONS WHERE
THE GATE OPENS 90° OR LESS**

**FOR INSTALLATIONS WHERE THE
GATE OPENS MORE THAN 90°**

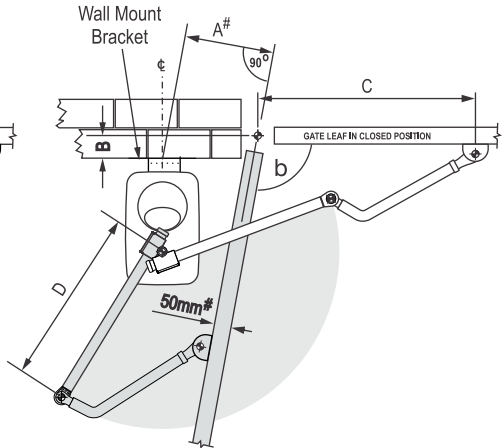
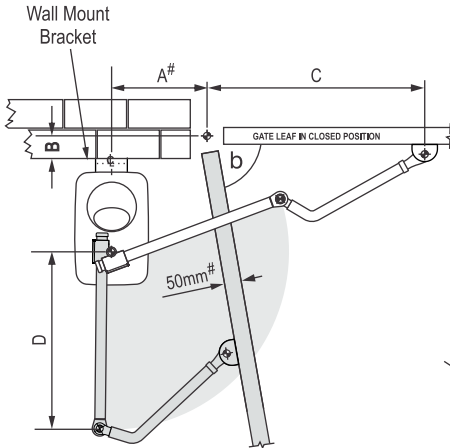

b	A#	B	C	D
Gate Opening Angle (Degrees)	Gate Centre to Bracket Centre	Hinge Centre to Mounting Face	Hinge Centre to Gate Bracket	Drive Arm Length
60	140 to 180 (140)	50 to 220 (180)	(700)	(250)
70	180 to 220 (180)	50 to 220 (180)	(700)	(300)
80	180 to 260 (180)	50 to 220 (140)	(700)	(350)
90	170 to 350 (210)	50 to 220 (140)	(700)	(420)
100	230 to 370 (270)	50 to 220 (180)	(700)	(480)
110	290 to 400 (330)	50 to 140 (80)	(700)	(500)
120	340 to 410 (380)	50 to 140 (80)	(610)	(500)

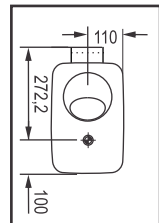

- Ensure that the gate does not exceed the relevant specifications on page 9.
- Recommended values are shown in bold type.
- All dimensions shown are indicated in millimetres.
- All recommended values will result in gates with similar opening times.

#The minimum value will ensure a clearance of 30mm if the gate



BE SURE TO USE A 'SHORT' CONNECTING ARM FOR THIS INSTALLATION TYPE.

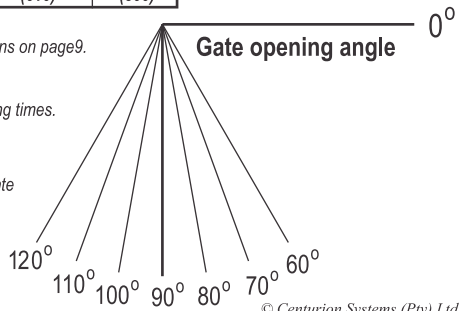

© Centurion Systems (Pty) Ltd

Figure 10 Determining Wall Bracket Position for Perpendicular Wall Mount

PARALLEL WALL MOUNT

**FOR INSTALLATIONS WHERE
THE GATE OPENS LESS THAN 90°**

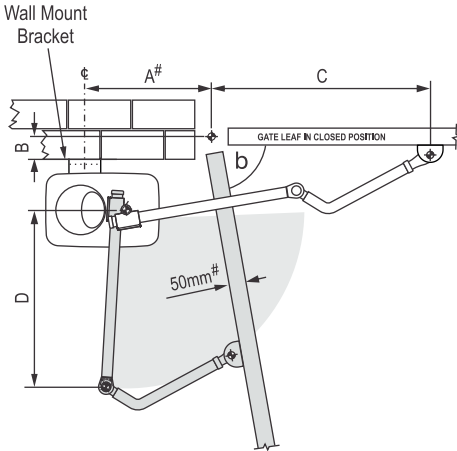

**FOR INSTALLATIONS WHERE THE
GATE OPENS MORE THAN 90°**

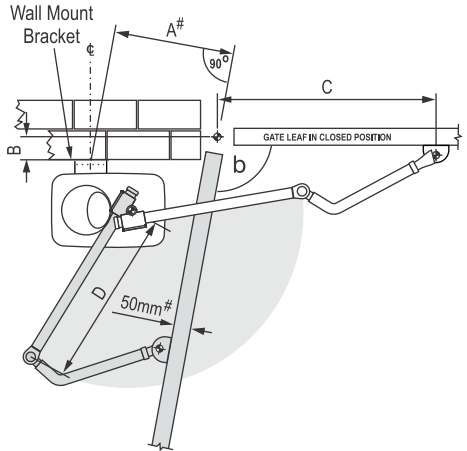

b	A#	B	C	D
Gate Opening Angle (Degrees)	Gate Centre to Bracket Centre	Hinge Centre to Mounting Face	Hinge Centre to Gate Bracket	Drive Arm Length
60	310 to 330 (310)	220 to 380 (340)	(700)	(250)
70	350 to 370 (350)	220 to 380 (340)	(700)	(300)
80	350 to 410 (350)	220 to 380 (300)	(700)	(350)
90	340 to 500 (380)	220 to 380 (300)	(700)	(420)
100	370 to 500 (400)	220 to 380 (340)	(700)	(480)
110	390 to 490 (430)	220 to 300 (240)	(700)	(500)
120	400 to 460 (440)	220 to 300 (240)	(610)	(500)

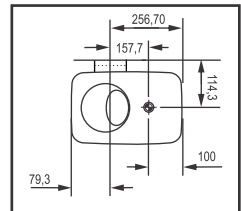

- Ensure that the gate does not exceed the relevant specifications on page 9.
- Recommended values are shown in bold type.
- All dimensions shown are indicated in millimetres.
- All recommended values will result in gates with similar opening times.

#The minimum value will ensure a clearance of 30mm if the gate



BE SURE TO USE A 'SHORT' CONNECTING ARM FOR THIS INSTALLATION TYPE.

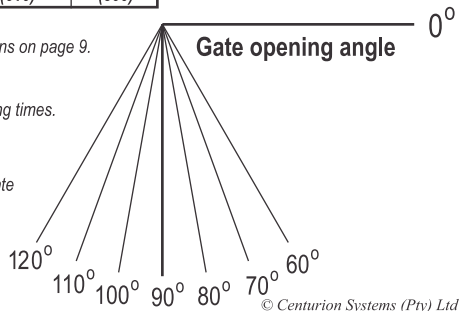

© Centurion Systems (Pty) Ltd

Figure 11 Determining Wall Bracket Position for Parallel Wall Mount

GATE BRACKET LOCATION & PEDESTAL HEIGHT FOR PEDESTAL MOUNT INSTALLATION

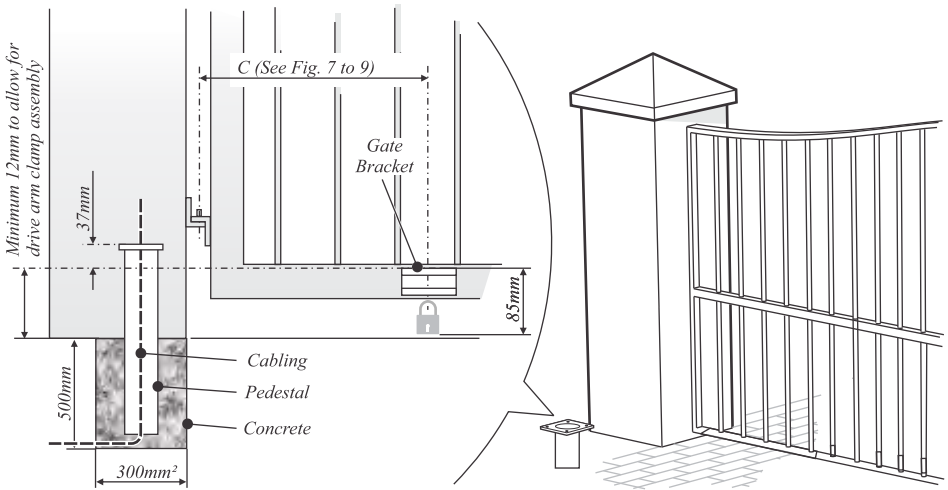

GATE & WALL BRACKET LOCATION FOR VERTICAL WALL MOUNT INSTALLATION

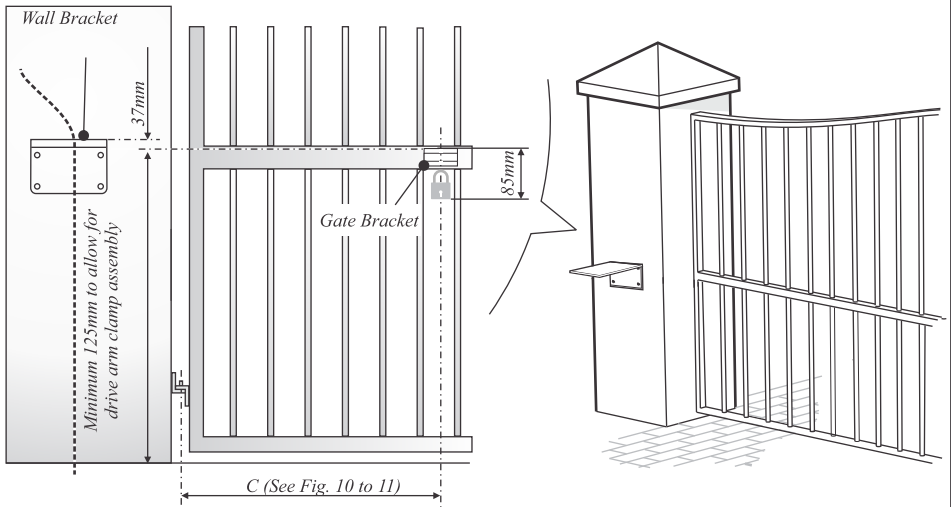

Figure 12 Determine the Position of the Gate Bracket and Pedestal or Wall Bracket

- Determine a suitable position for the pedestal or wall mount bracket using the swing angle and dimensions A and B as found in the tables in Fig 7 to 11. (Values given in BOLD indicate the recommended dimensions). Before finalising the position of the pedestal or wall bracket, see points 5 & 6 below.

If it is not possible to find a suitable position within the given A and B dimensions, then contact your local Centurion Systems (Pty) Ltd sales office.

- Determine the vertical height of the pedestal or wall bracket to be 37mm above the gate bracket as in Fig. 12.
- If installing a pedestal, prepare a square hole for the pedestal foundation according to Fig. 12 at the predetermined position.

Mount Gate Bracket

- Locate a suitable place for mounting the gate bracket according to dimension "C" as shown in Fig. 12

By positioning the gate bracket further from the hinge (increasing the "C" value), it would:

- increase the time it takes to open the gate (make it slower),
 - improve the gates locking and security properties.
- (The A dimension does not affect the opening time or other properties of the gate.)*

- Determine the height of the bracket above ground by taking into account drive arm clearance and ground clearance for the padlock. (See Fig. 12). Once correctly located, weld or screw the gate bracket to the gate using the two M4 screws provided.

Route Cables & Secure Motor Mounting

- Route cables as determined in the cabling plan (Fig. 5), making sure that all cables protrude at least 400mm above the pedestal mounting plate or wall mount bracket as shown in Fig. 13.

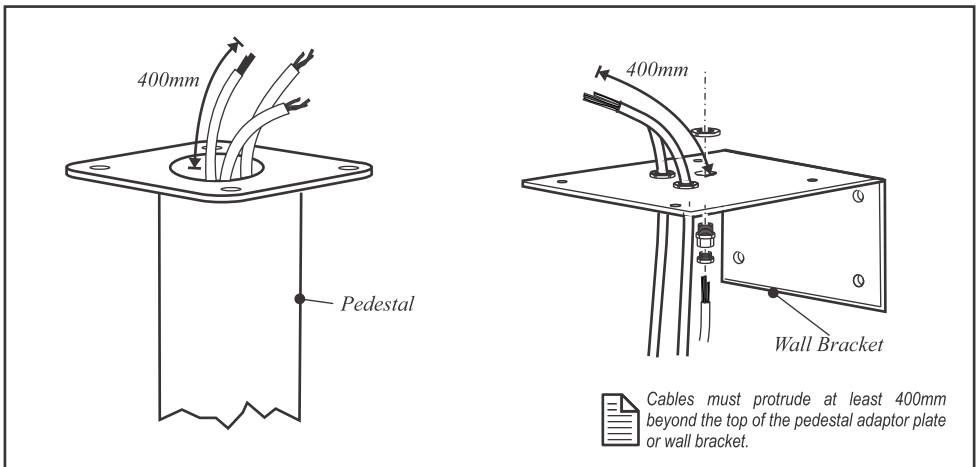

Figure 13 Pedestal Adaptor Plate Assembly

- Securely concrete the pedestal into position making sure that it is vertical, and at the correct height relative to the gate bracket, as shown in Fig. 12. Allow concrete sufficient time to cure.

In the case of a wall mount installation, securely fix the wall mount bracket in the determined position to the wall or pillar using four M12 Rawl bolts.

Fasten Gearbox in Position

- Fasten the motor onto the pedestal adaptor plate or wall bracket, as shown in Fig. 14, using the M8 bolts and spring washers as supplied.

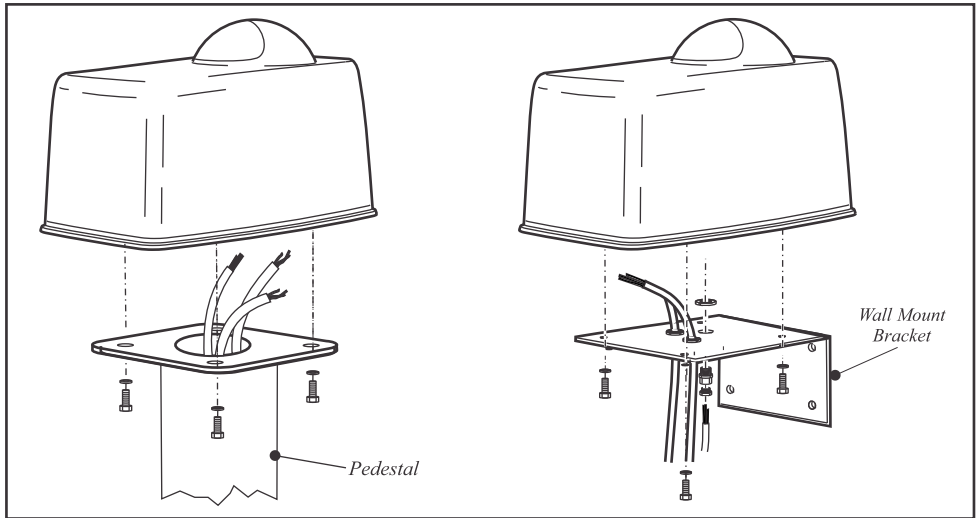

Figure 14 Secure Gearbox to Pedestal Adaptor or Wall Mount Bracket

Determine Drive Arm Length

- Depending on the particular installation type, determine the drive arm length as follows:

For Standard Pedestal & Outward Opening Gates:

Measure dimensions L (long) and S (short) as in Fig. 15 and calculate the drive arm length D as shown in Fig. 15. **DO NOT CUT THE DRIVE ARM TO THIS LENGTH.** Cut the drive arm at least 50mm longer than D. The cut length is therefore = $D + 50\text{mm}$. (See Fig. 16)

For Pedestal Mounted Installations With Limited Space:

From the tables on Fig. 8, determine the drive arm length D, and select the **boldface** value if the motor is mounted in the recommended. **DO NOT CUT THE DRIVE ARM TO THIS LENGTH.** Cut the drive arm at least 50mm longer than D. The cut length is therefore = $D + 50\text{mm}$ (see Fig. 16)

Assemble the drive arm and connecting arm as in steps 11 to 18 and check the gate operation

- If the drive arm interferes with the gate or,
- If the ball joint on the drive arm is more than 30mm from the obstructing wall, then,
Shorten the drive arm by 25mm and repeat the process until the gate operates smoothly.

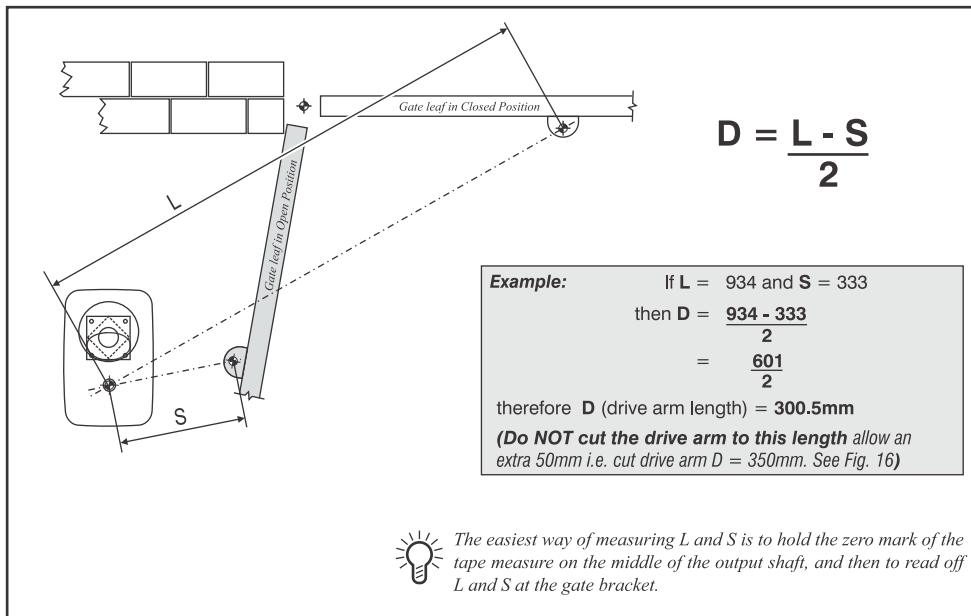

Figure 15 Determining Drive Arm Length for Standard Pedestal & Outward Opening Gates

For Parallel and Perpendicular Wall Mount Installations:

Determine the drive arm length (D) from Figures 10 and 11. **DO NOT CUT THE DRIVE ARM TO THIS LENGTH.** Cut the drive arm at least 50mm longer than D. The cut length therefore = $D + 50$ mm (see Fig. 16)

Fit the Drive Arm

11. Once the drive arm has been cut to length, regardless of installation type, put the gearbox into manual mode (See Page 43)
12. Fit the drive arm and connecting arm assembly to the motor output shaft as in Fig. 20, using the supplied M10 or M12 bolt and washer (Check that the flats on the shaft and clamp line up before tightening up the bolt.)

Set the Connecting Arm

13. Prepare the connecting arm for installation, by moving the inner tube to the retracted position (see Fig. 17). Turn the inner tube clockwise

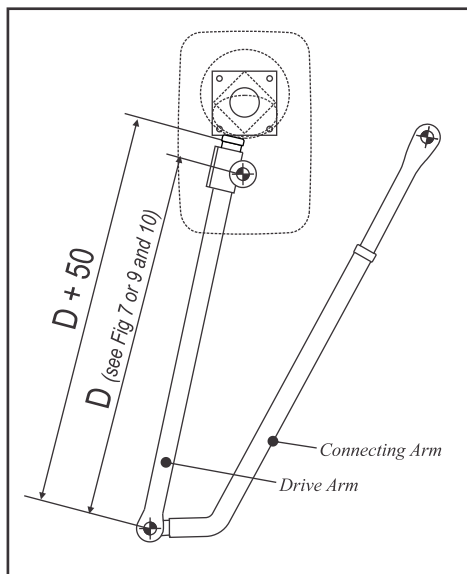

Figure 16 Adjust Drive Arm length

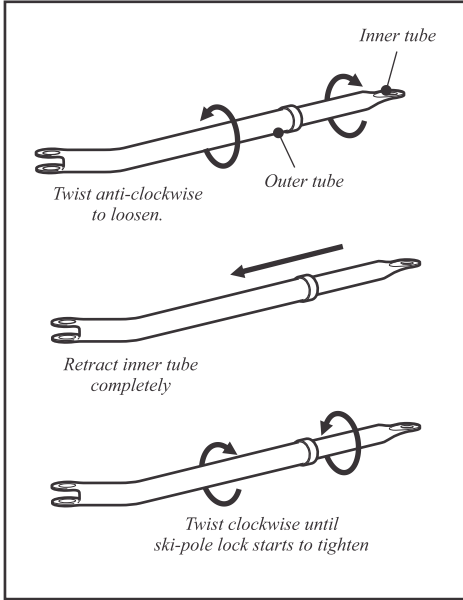

Figure 17 Prepare Connecting Arm For Installation

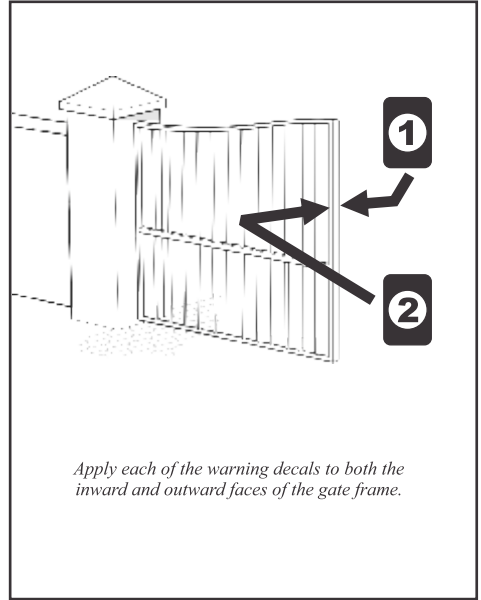

Figure 18 Apply warning decals to gate

until the ski-pole lock starts to tighten. Do not over tighten, as that will make the final adjustment more difficult.

14. Open the gate, and possibly swing the drive arm slightly, until the connecting arm can be fitted into the gate bracket using the clevis pin (see Fig. 19)
15. Using the gate as a lever, slowly close the gate to extend the connecting arm. **When the gate is completely closed, the hinge points of the connecting and drive arms must be in a straight line** (see Fig. 22).
16. In a double leaf gate system, ensure that both gates are correctly aligned in the closed position.
17. Carefully unhook the connecting arm from the gate bracket making sure it's length is not altered. Hand tighten the connecting arm ski-pole lock and reconnect it to the gate bracket.
18. Manually operate the gate leaf and check that it opens sufficiently.



If the gate opens too little, lengthen the drive arm by 10mm and readjust the connecting arm by restarting from step 14.

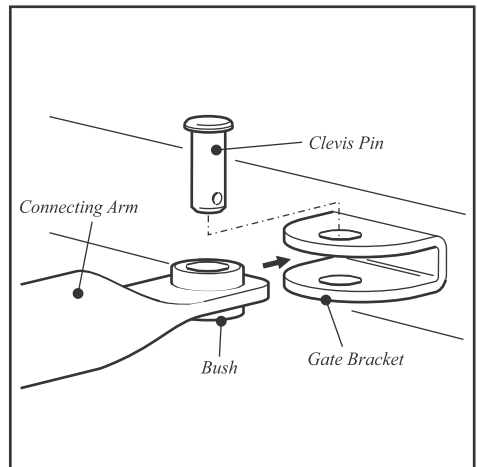

Figure 19 Fit Connecting Arm to Gate Bracket

19. Once a satisfactory gate opening has been achieved, the connecting arm must be fully tightened: Disconnect the connecting arm from the gate bracket. Remove the bushes from the front end of the connecting arm. Using a large screwdriver or similar lever, tighten the ski-pole lock using half-turns until it is as tight as possible and aligned with the gate bracket. Replace the bushes and reconnect the connecting arm to the gate as shown in Fig. 19.
20. Apply the two warning decals supplied to the inward and outward facing sides of the gate frame about 1.2m above ground at the non-hinged end of the gate.

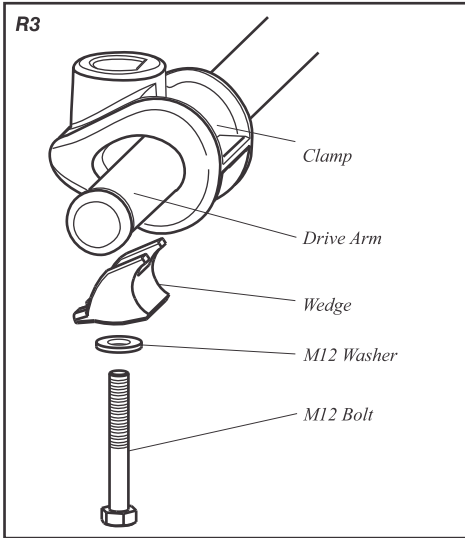

Figure 20 Assemble Clamp to Drive Arm (R3 only)

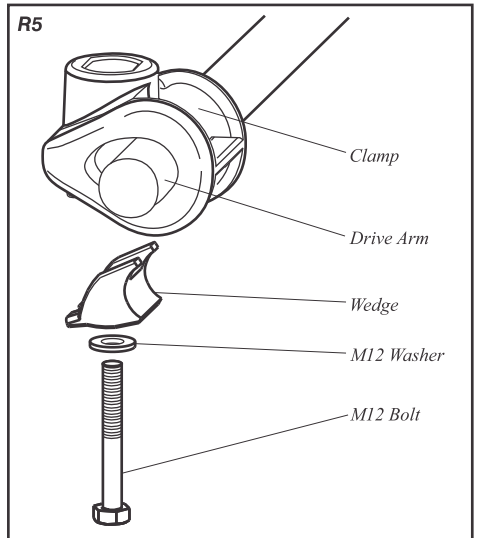

Figure 21 Assemble Clamp to Drive Arm (R5 only)

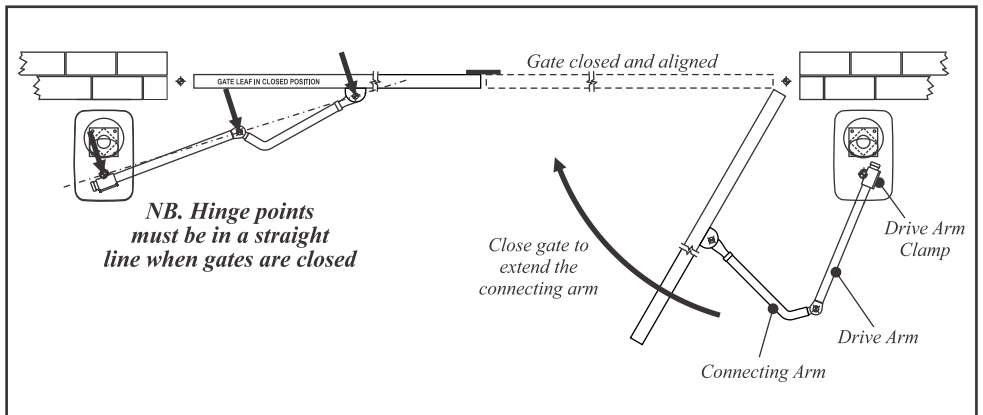

Figure 22 Align Gates

Electrical Set-up

⚠ WARNING

1. Always check that the circuit breaker in the electrical panel is in the OFF position, and that all high voltage circuits (more than 42.4V) are completely isolated from the mains supply before doing any work.
2. Ensure that all low voltage systems (Less than 42.4V) are suitably protected from damage, by disconnecting all sources of power such as chargers and batteries before doing any work.
3. All electrical work must be carried out according to the requirements of all applicable local electrical codes. (It is recommended that a licensed electrical contractor perform such work.)

Connect all wiring

1. Connect all cables as required to the control card and battery charger, according to the wiring diagrams on page 48 & 49.
2. Check that the battery charger is plugged into the controller board as shown in Fig. 23
3. Check that the **power source link is in the STD position** when using a standard CP84ER5V01 charger, or **PSU position** for PSUx power supply driven installations. See Fig. 24

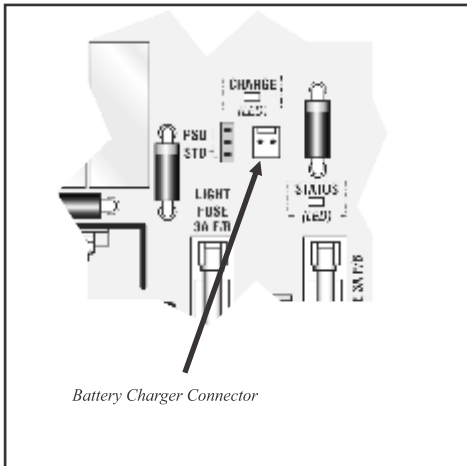

Figure 23 CP75 Controller Battery Charger Connector

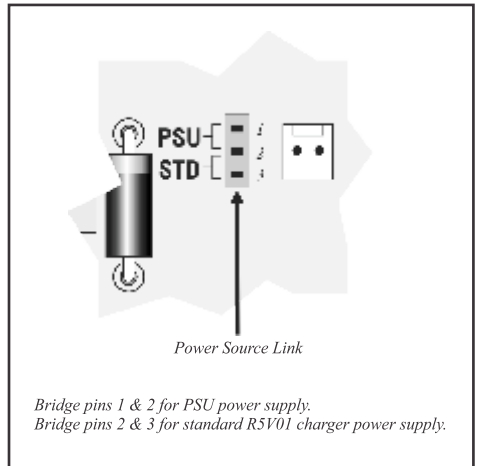

Figure 24 CP75 Power Source Link

Set up the gate origin/s

4. With both the master and slave gates still in manual mode, **move both gates to the closed position.**
5. Flip over the controller enclosure. Open the override dust cover as shown in Fig. 31, and remove the origin tool from its storage position (see Fig. 25).
6. Insert the origin setup tool into the release mechanism with a twist action, until the tool is snugly seated (see Fig. 26).
7. Now turn the origin setup tool, until the arrow on the set-up tool lines up with the mark on the release mechanism cover as in Fig. 27 (Take care to line it up with the correct mark.)

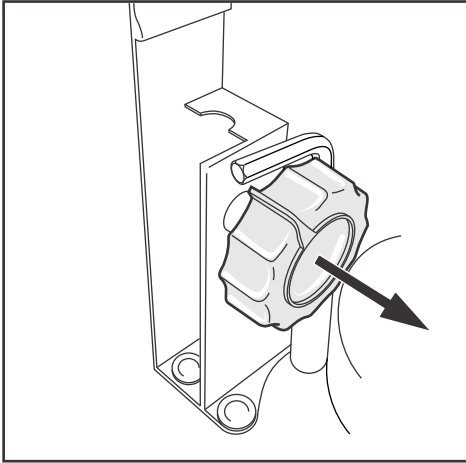

Figure 25 Setup tool in stored position

8. Repeat the procedure for the other motor in a double swing system.
9. Return the origin tool to its storage position on the upright pillar and close the override dust cover.
10. With the gates still in manual mode, **move the gates to the ½ way open position**, and unscrew the manual release until the top of the screw is flush with the top of the shaft. (The gearbox does not have to be engaged with the drive arm, when in the ½ way open position.)

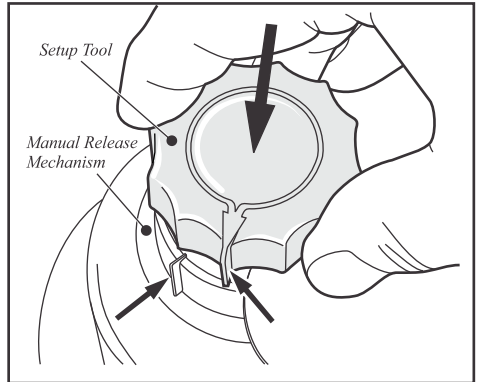

Figure 26 Fit Setup Tool into Release Mechanism

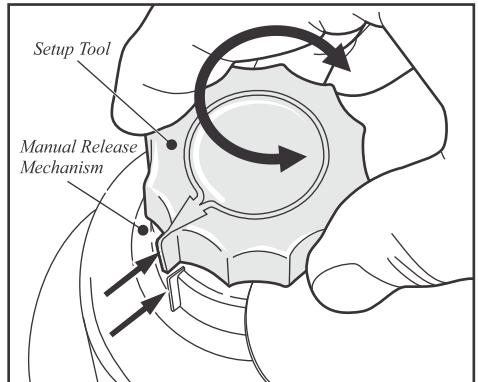

Figure 27 Twist Setup Tool Until Marks Align

Get into programming mode

11. **Remove ALL power** from the controller, i.e. charger plug and battery.
12. **Fit the SET link** to the SET pins as shown in Fig. 28.
13. **Reapply power** by reconnecting the charger plug, and then the battery to the controller.
14. Immediately after reconnecting the power, the STATUS light will flash 5 times. The SET and L2 lights will now be on. You are now in programming mode.

(See *Set-up Troubleshooting Guide* step 14).

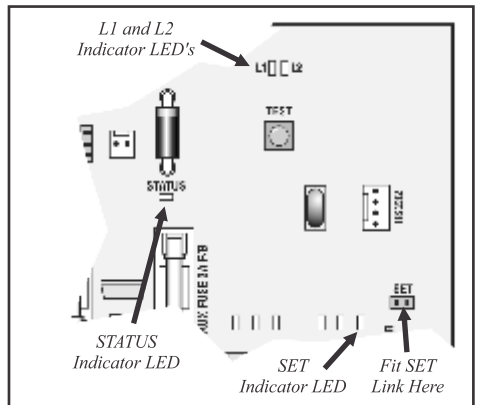



Figure 28 Controller SET Link & Programming LED's

Select either Master or Slave motor setup

 (The gate limits of the Master and Slave motors are set independently of each other.)

15. **Press and hold** the TEST button (Fig 29) down for 1 flash of L1, and then release. L2 will go off, and L1 will now be flashing once per second.
16. Again **press and hold** TEST button, but this time monitor the STATUS light. **Release** the TEST button after **1 flash for selecting the Master motor**, or **2 flashes for the Slave motor**. The STATUS light will turn on to indicate that gate setup is in progress.

(See *Set-up Troubleshooting Guide* step 16) 

Set the gate limits

17. To set the closed limit **press and hold** the TEST button. The master (or slave) motor will activate, and within ± 60 sec the release mechanism will engage, and the master (or slave) leaf will begin to slowly CLOSE.

If the gate OPENS, release the TEST button and swap the master or slave motor wires as shown in Fig. 30. To continue the setup, **press and hold** the test button as in step 17.

(See *Set-up Troubleshooting Guide* step 17) 

18. When the connecting and drive arm hinge points are in a straight line (Fig. 22), **release the TEST button**. (The gate will now be in the CLOSED position). Light L1 must now be **OFF** when setting the Master, or L2 **OFF** when setting the Slave motor.

 For fine adjustment of the gate CLOSED position, lengthen or shorten the connecting arm accordingly.

(See *Set-up Troubleshooting Guide* step 18) 

 *Has the gate gone too far/short? Simply **remove and refit** the SET link. The gate will OPEN slightly. Try again by **pressing, holding and releasing** the test button, as in step 17 and 18.*

19. To set the OPEN limit, again **press and hold** the TEST button. The gate will slowly OPEN.

(See *Set-up Troubleshooting Guide* step 19) 

20. When the gate has reached the OPEN position, **release the TEST button**. Light L1 must be **on** when setting the Master, or L2 **on** when setting the Slave motor.

(See *Set-up Troubleshooting Guide* step 20) 

 *Has the gate gone too far/short? Simply **remove and refit** the SET link. The gate will CLOSE slightly. Try again by **pressing, holding and releasing** the test button, as in step 19 and 20.*

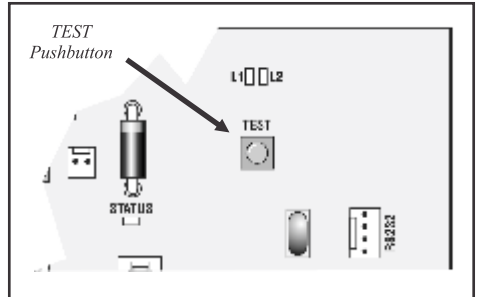

Figure 29 CP75 Controller TEST Pushbutton

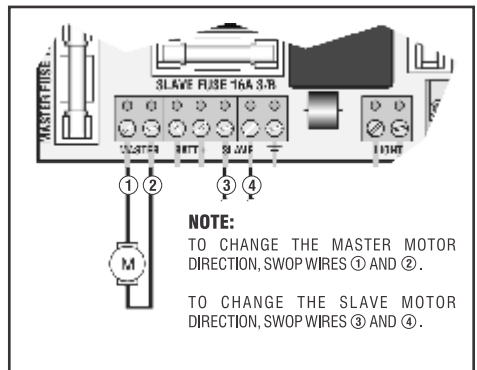

Figure 30 CP75 Controller Motor Wire Connections

21. Then **press and release** the TEST button once more to confirm the OPEN limit.

When setting Master motor limits:

22. The gate will close completely, pause and then open to the minimum pedestrian position.

 *If a larger pedestrian opening is required, momentarily short the PED input to COM to jog the master leaf further open.*

At the required position, **press and release** the TEST button.

The MASTER gate will open fully, then the SLAVE gate (where fitted) will close slightly. The STATUS light will flash 5 times, and L2 will come on, to indicate that the limits were set.

The control card has now returned to the initial programming mode.

When setting Slave motor limits:

The gate will close slightly. The STATUS light will flash 5 times, and L2 will come on, to indicate that the limits were set.

The control card has now returned to the initial programming mode.

23. If no additional Features are required, then exit programming mode by removing the SET link. Store the link by pushing it over **ONE** of the two pins.

(See *Set-up Troubleshooting Guide* step 23) 

24. Open and close the gate a few times to check operation.

(See *Set-up Troubleshooting Guide* step 24) 

Setting Additional Features (Optional)

The default factory settings on the CP75 Controller have been selected to suit most applications. In many cases there would be no need to change the default settings. A list of features can be found on page 47, with a detailed description of each feature on page 32.

Determine What Features are Required

25. Determine from Table 2 on Page 47 what Features are required together with the STATUS or COUNT value.

Example: “To turn the Autoclose Feature ON”: According to Table 2 the Autoclose feature is Feature number 2, and to turn it ON is a status of 1.

Get Into Programming Mode (Exactly the same as for limits setup)

26. **Remove ALL power** from the controller, i.e. charger plug and battery.

27. **Fit the SET link** to the SET pins as shown in figure 28.

28. **Reapply power** by reconnecting the charger plug, and then the battery to the controller.

29. Immediately after reconnecting the power, the STATUS light must flash 5 times, and then SET and L2 will come on. You are now in programming mode.

(See *Fault Finder's Guide* step 14 or 29) 

Selecting the Feature to Change

(This is the first of two steps in setting a Feature. This only **SELECTS** the feature to change).

30. To select the Feature to change, **Press and hold** the TEST button while monitoring L1.
31. L1 will flash once then go off, twice in short succession then go off, three times then go off, etc. **Release the TEST button** when the number of flashes is the same as the Feature number to select.

Example 1:

To set the MODE OF OPERATION to CONDOMINIUM (That is Feature number 4, to a status of 2 according to table 2 on page 47) **Press and hold** the TEST button while monitoring L1:

The L1 light will flash once and pause,
then flash twice and pause....
then flash three times and pause....
then flash four times and pause....

At this moment **release the TEST** button to select Feature 4. L2 will turn off, and L1 will keep on flashing four times and pausing to indicate that **Feature 4 is selected**



NOTE: The STATUS of the Feature is not changed yet, the feature has only been selected to be changed!

32. If an incorrect Feature is selected, then remove and re-apply power and re-start from step 30. None of the Feature settings will have been altered at this stage.

Changing the STATUS or COUNT value of a Feature.

33. To set the **STATUS** value of the Autoclose, Mode of operation, Collision Sensitivity, Positive Close mode, Pre-flashing, or the Leaf delay Features:

Press and hold the TEST button while monitoring the STATUS light. The STATUS light will flash the same as for selecting a Feature. (See Step 31) Release the TEST button when the number of flashes is the same as the STATUS value required.

Example 1 (continued):

To set the MODE OF OPERATION to CONDOMINIUM:

After selecting the Feature, again **press and hold** the TEST button while monitoring the STATUS light:

The L1 light will flash once and pause,
then flash twice and pause.....

At this moment **release the TEST** button to give a STATUS value of 2. The mode of operation has been changed to condominium.



NOTE: Only after setting the STATUS, would the ode of Operation be changed to reversing!

L2 will come back on, indicating that the STATUS has been updated.

34. To set the **COUNT** value of the Autoclose timer, Pedestrian Autoclose time, Courtesy light timer, Autoclose override timer, Pre-flashing time, Collision counter, or the Leaf delay time Features:

Press and hold the TEST button while monitoring the STATUS light. After a slight pause, the STATUS light will start flashing at an even rate. Count all the flashes, and **release the TEST** button when the number of flashes is the same as the COUNT value required.

Example 2:

Set the AUTOCLOSE TIME to 10 seconds (That is Feature number 3, to a COUNT value of 10):

First select the Feature number 3 as in steps 30 to 32. Then **press and hold** the TEST button while monitoring the STATUS light:

After a slight pause, the STATUS light will start flashing regularly:

Flash (1), Flash (2), Flash (3), Flash (4), Flash (5), Flash (6),Flash (9),

Flash (10).

At this moment **release the TEST** button to give a COUNT value of 10. This sets the Autoclose timer to 10 seconds.

L2 will come back on, indicating that the COUNT has been updated.

Controller Features

The terminology "FEATURE 2-2" refers to Feature number 2 with a status of 2. "FEATURE 3- COUNT" refers to Feature number 3, with a user specified COUNT value.

Autoclose

This can be programmed ON (FEATURE 2-1) or OFF (FEATURE 2-2). The factory default is OFF. Autoclose has the function of automatically closing a gate after a preset Autoclose time. Autoclose must not be turned OFF in condominium or PIRAC mode.

A gate that is stopped while opening will always Autoclose. A gate that is stopped while closing will remain where it is stopped indefinitely.

This time is set in FEATURE 3-COUNT. It can be set from 1 to 255 seconds. It is possible for the user to temporarily turn off Autoclose when the mode of operation is either STANDARD and REVERSING. This is done by applying an impulse to the TRG input at the time of opening the gate, for a period of time longer than the AUTOCLOSE OVERRIDE TIME as set in FEATURE 8-COUNT. To provide feedback that the override signal has operated, the gate will stop opening after the override time. The instant the impulse is removed the gate will complete its opening cycle. The Autoclose is now off and the gate will remain open indefinitely. The next impulse received on TRG will initiate the closing cycle and the Autoclose is automatically re-instated.

Mode of Operation

It is possible to select four different Modes of Operation: STANDARD, CONDOMINIUM, PIRAC and REVERSING (FEATURE 4-1 to 4-4). Only one mode can be activated at any one time. All the modes are triggered by the contact present between the TRG input terminal and the COM terminal.

STANDARD MODE (FEATURE 4-1) (This is the factory default mode) - A trigger impulse will cause the gate to start moving (either open or closed depending on its position). A second

impulse while the gate is still moving will stop the gate. A third impulse will cause the gate to reverse its direction of travel, i.e. the action is START - STOP - REVERSE.

CONDIMINIUM MODE (FEATURE 4-2) - Any trigger will cause a gate, which is closed or closing to open or re-open. If not already active, the Autoclose will automatically be turned on when Condominium Mode is selected. It is only the Autoclose signal, which can close a gate in Condominium Mode. If a trigger impulse is given while the gate is open the Autoclose time is reset to its preset value.

PIRAC MODE (FEATURE 4-3) - An acronym for Passive Infra red Autoclose, this mode operates similarly to Condominium Mode but instead of waiting for the Autoclose timer to close the gate, it will close as soon as an object that has passed through the gate clears the infrared beam. If the beam is not broken the gate will get to its fully open position and close after the preset Autoclose time. This feature will only operate if infrared safety beams or if an inductive loop is fitted (IRB terminal).

REVERSING MODE (FEATURE 4-4)- This mode is similar to standard mode but instead of stopping a gate when it is in motion, a trigger will cause the gate to reverse its direction of travel. It is thus impossible to leave a gate stationary in a partly open position. The only two normally stable states are fully open or fully closed. If the Autoclose is ON then the gate will always tend towards being closed.

Pedestrian Autoclose Time (FEATURE 5 - COUNT)

A separate Autocloser timer exists for the pedestrian opening. The time can be set from 1 to 255 seconds but cannot be turned off completely. The default time is 5 seconds.

Collision Sensitivity (FEATURE 7-1 to 7-3) (The factory default is 7-1)

If the gate is obstructed the internal collision circuitry will activate. When the gate is opening, and it is obstructed the gate will stop. Master and slave gates operate independently of each other while opening i.e. a collision to the master gate will not stop the slave gate from opening fully. During closing however, an obstruction to either master or slave gate will cause both gates to immediately stop and reverse direction. There is a counter (FEATURE 12-COUNT) that monitors the number of collisions. If the collision count is reached before both gates reach the fully closed position all trigger signals are inhibited for a 1 minute period. The STATUS LED flashing four times indicates this condition. After the 1 minute period, triggers will again become active, (with the exception of Autoclose). The fault indication will continue to flash indefinitely after the 1 minute period but will clear after the 1 minute period is a valid trigger is given. The collision counter resets to zero after the 1 minute delay, or the processor is reset. (e.g. By removing all power from the controller.)

Courtesy (Pillar) Light:

The pillar circuit has multiple functions:

- It operates as a courtesy light and switches on for a timed period. (The factory default is 2 minutes) (set by FEATURE 6-COUNT) every time the gate triggers.
- It can be turned on for the preset timed period, by the application of a short impulse between the SET terminal and COM.
- It can be turned ON permanently by application of an impulse longer than 3 seconds on SET and COM terminals. A short impulse thereafter will switch the lights off. The gate will not trigger open when using the SET trigger. The fact that the pillar light is ON permanently is indicated by the STATUS LED flashing once every 2 seconds.

- When the PED input is triggered the pillar light flashes for an adjustable (1 to 255 seconds) pre-flash time (FEATURE 11 - COUNT) before the pedestrian gate opens. (Default pre-flash time is 2 seconds).
- The contact can be used to operate a lamp, which will warn that the gate is about to open. Selection of pre-flashing is done in FEATURE 10. Three modes and OFF are selectable (The factory default is OFF):
 - Mode 1 - Light comes on only while gates are in motion.
 - Mode 2 - Light flashes at 1Hz for the pre-flash time and then flashes in synchronism with the STATUS LED while the gates are in motion.
 - Mode 3 - Light comes on for the pre-flash time and while the gates are in motion.

Positive Close Mode:

Setting Positive Close Mode to ON (FEATURE 9-1) (default is OFF, FEATURE 9-2) will allow the gate to drive up hard to an end stop without causing the collision circuitry to operate. This Feature operates only during the last 10 degrees of arm travel in the closing mode.

Leaf Delay:

(Feature 13 & 14) It is possible to select three different types of leaf delay. Feature 14 selects the delay time.

FEATURE 13-1	Will delay the slave motor during its opening cycle only for the leaf delay time.
FEATURE 13-2	Will delay the master motor during its closing cycle. This is to ensure that the slave gate will reach the fully closed positions before the master leaf. For example, in situations where the master gate has a flap which must close against the slave gate.
FEATURE 13-3	Will cause the slave gate to delay on opening and the master gate to delay on closing.
FEATURE 13-4	Turns all leaf delays OFF (Default setting).
FEATURE 14-COUNT	Allows the leaf delay to be set from 1 to 255 seconds. The default delay time is 2 seconds.



NOTE: The solenoid lock strike time is set via the leaf delay timer.

All the known causes of problems are listed, according to the step number in the gate limits setup instructions.

Set-up Troubleshooting Guide

SET-UP STEP	PROBLEM	POSSIBLE CAUSES & SOLUTIONS TO PROBLEM
14 or 29	<p>SET light is not on:</p> <p>L2 is not on:</p> <p>STATUS light did not flash 5 times:</p> <p>L1 is flashing:</p>	<p>Check that the SET link is correctly fitted. Fit and remove the link a few times to ensure good contact.</p> <p>All sources of power on the card must be removed. Check by confirming that all the lights turn off, before reconnecting the power with the set link fitted.</p> <p>The controller did not “boot-up” correctly. Try to fit the charger plug before reconnecting the battery.</p> <p>Check for and remove latching inputs on the TRG terminal then restart from step 11.</p>
16	STATUS light flashes five times and L2 turns on.	<p>This could be due to:</p> <ul style="list-style-type: none"> • The gate not being correctly positioned. Move the gate to its half way position and restart from step 14. • The origin not being set correctly. Restart the setup from step 14. • A faulty origin PCB or cable. To check, go out of programming mode by removing the SET link. Then insert the origin setup tool, turn the tool a full revolution while monitoring L1 and L2. If either L1 or L2 changed state during the adjustment, then the origin system for the motor tested is OK, restart the setup from step 4. • If not, check the status of all plugs and wiring. If the problem is not resolved then the sensor, cable or controller might be faulty.
17	<p>There is a click but the motor does not turn. The STATUS light flashes rapidly, then flashes five times. L2 turns on.</p> <p>There is a click, the motor turns but the gate does not move.</p>	<p>This could be due to:</p> <ul style="list-style-type: none"> • The motor not being connected to the controller, or • The motor fuse could be blown, or • The motor is faulty. Check motor by connecting motor leads directly to the battery. • Check for loose connections or corrosion on battery terminals. • The motor cables are too thin. They must be 2,5mm² • Check for low battery condition by following procedure A on page 41. <p>Correct the problem, remove and refit the SET link and start from step 17.</p> <p>The manual release mechanism is still in manual mode. The manual release must be unscrewed as in step 10.</p> <p>Not enough time is allowed for the manual release to re-engage. To continue setup, press the TEST button as in step 17</p>

Set-up Troubleshooting Guide Continued...

<p>17 <i>(continued)</i></p>	<p>Motor briefly starts and then stops, and STATUS flashes 5 times.</p> <p>Motor starts then stops after 1 second (STATUS flashes 5 times)</p>	<p>The battery is not connected. Correct the problem, remove and refit the SET link and start from step 17.</p> <ul style="list-style-type: none"> Faulty DOSS sensor or cable. <p>The DOSS sensor system is faulty. Is the DOSS harness plugged in? If so, there could be a fault on the sensor, cable or controller.</p>
<p>18</p>	<p>Light L1 is on when setting the Master, or L2 is on when setting the Slave motor:</p>	<p>The leaf has not passed through the origin yet. In which case:</p> <ul style="list-style-type: none"> Either keep on pressing and holding the test button until the required gate closed position is reached with L1 off, or Mechanically reset the gate origin by restarting from step 4.
<p>19</p>	<p>The gate does not open, STATUS light flashes five times and L2 turns on.</p>	<p>The battery is discharged. Replace or charge the battery.</p>
<p>20</p>	<p>Light L1 is off when setting the Master, or L2 is off when setting the Slave motor:</p>	<p>The leaf has not passed through the origin yet. In which case:</p> <ul style="list-style-type: none"> Either keep on pressing and holding the test button until the required gate closed position is reached with L1 or L2 on, or Mechanically reset the gate origin by restarting from step 4.
<p>23</p>	<p>L2 and SET did not go off</p>	<p>Check for, and remove, inputs on the SET terminal.</p>
<p>24</p>	<p>The gate stopped short of either the open or closed position:</p> <p>The gate does not close when pressing TEST:</p> <p>The gates do not close simultaneously:</p>	<ul style="list-style-type: none"> The gate limits were not set correctly. Restart from step 4. The gate dynamics could be detected as a collision by the controller. Set the gate collision sensitivity to be less sensitive (feature 7 to Status 2 or 3) The open position of the gate was not confirmed by pressing the TEST button as in step 21. Restart from step 11. Mode of operation could be set to condominium, which only allows the gate to be closed by the Autoclose timer. The safety beams or holiday lockout features could be activated. Check the IRB and LCK lights, both must be ON for normal operation. The link between COMMON and LCK might not be fitted, when the safety lockout feature id not used. The link between COMMON and IRB might not be fitted, when safety beams are not used. <p>One of the leaf delay modes is selected. The gates can be set to close simultaneously by setting feature 13 to status 4</p>

Set-up Troubleshooting Guide Continued...

<p>24 (continued)</p>	<p>The motors keep on driving past the closed position:</p> <p>The slave gate runs slower than the master gate:</p> <p>The gate starts and then stops moving when gate is fully OPEN and triggered to close.</p>	<p>Positive close mode has been activated. Deactivate positive close mode by setting feature 9 to 1.</p> <p>The slave motor cables are too thin, ensure that the cables are at least 2.5mm²</p> <p>The installation geometry does not give the motor enough mechanical advantage to get the gate started.</p> <ul style="list-style-type: none"> For limited space and wall mounted installations, shorten the drive arm by 25mm and re-adjust the connecting arm as in steps 17 to 213 of the mechanical setup. Alternatively, set the collision sensitivity, feature 7, to status 2 (medium) or 3 (low).
---------------------------	---	---

Fault Finding Guide

PROBLEM	POSSIBLE CAUSES & SOLUTIONS TO PROBLEM
<p>1 Gate does not open at all:</p>	<ul style="list-style-type: none"> Check that you are out of programming mode, SET light must be OFF. LCK (lockout) input activated. Green LCK light should be ON. IRB (IR beams) input activated (Gates would not move once open). Green IRB light should be ON. Check cabling, alignment and 12V power (3A auxiliary fuse). Latching input on TRG or FRX. (Both TRG and FRX lights must be off for gate to operate.) Check the battery condition with procedure A: Low battery voltage condition, later in this section. If STATUS light flashes four times then the operator is in Multiple Collision Mode. Remove & reapply all power, or wait 60 seconds to reset operation. If required, check with procedure B: False collision detection, later in this section. If the problem persists, the CP75 main controller might be faulty.

Fault Finding Guide Continued...

PROBLEM	POSSIBLE CAUSES & SOLUTIONS TO PROBLEM
<p>2 Gate does not move, but the relays “click” when the unit is activated:</p>	<ul style="list-style-type: none"> • Check that you are out of programming mode, SET light must be OFF. • Check the battery condition with procedure A: Low battery voltage condition, later in this section. • Check the motor wires. • If STATUS light flashes four times then the operator is in Multiple Collision Mode. Remove & reapply all power, or wait 60 seconds to reset operation. If required, check with procedure B: False collision detection, later in this section. • If the problem persists, the CP75 main controller might be faulty.
<p>3 Gate moves a short distance and stops:</p>	<ul style="list-style-type: none"> • Check the battery condition with procedure A: Low battery voltage condition, especially if the STATUS light flashes three times. • Motor wires use for the SLAVE operator are too thin. • Check for false collisions with procedure B: False collision detection, later in this section (STATUS light could also flash four times if the number of detected collisions exceeded the COLLISION COUNTER feature value). • Intermittent IRB trigger. Check that the voltage applied to the beams are appropriate. • Spurious trigger. Remote with same coding operated in area, or intermittent short due to possible moisture on the FRX or TRG inputs. • If the problem is still not solved, the CP75 main controller might be faulty.
<p>4 Gate starts closing then stops & reopens:</p>	<ul style="list-style-type: none"> • Check collision sensitivity and other causes with procedure B: False collision detection.

PROBLEM	POSSIBLE CAUSES & SOLUTIONS TO PROBLEM
	<ul style="list-style-type: none"> • Check for intermittent IRB (IR Beam) triggers. (Check beam operation, alignment and supply voltage). • Intermittent/spurious signal on FRX or TRG if in CONDO,, PIRAC or REVERSING modes. (Standard mode would first stop then reverse) • If the problem is still not solved, the CP75 main controller might be faulty.
<p>5 Gate overruns its limits:</p>	<p>For both MASTER and SLAVE motors: (only the faulty gate's components need to be inspected)</p> <ul style="list-style-type: none"> • Check that the ORIGIN sensor wire harness is securely plugged into the CP75 (master controller) or CP74A (slave board), and securely into the ORIGIN sensor. • Check that the respective ORIGIN sensor is securely clipped into the housing. • Check if the gate origin was accidentally moved, steps 4 to 10 of the electrical setup. If so reset the limits. • For SLAVE motor, check the wiring of S1, S2 and S3 for continuity and short circuits. Look for and correct all loose connections and signs of corrosion, be sure to solder all joints. • Make sure that the ORIGIN dust cover is closed. (Ants could give intermittent false triggers). • If the problem is not solved, the CP75 main controller might be faulty.
<p>6 Gate opens on its own</p>	<ul style="list-style-type: none"> • Check for latched TRG or FRX input. (Respective lights would be on continuously). • Intermittent fault on TRG or FRX inputs. Look at all joints, switches, etc. (Underground joints with moisture buildup) • Outside transmitter with the same code. (Typically only with DIP switch type remotes) • Faulty receiver • Faulty electric fence • If the problem is still not solved, the CP75 main controller might be faulty.
<p>7 Unreliable Autoclose</p>	<ul style="list-style-type: none"> • Latching Receiver on TRG, would activate the Autoclose override feature.

Fault Finding Guide Continued...

PROBLEM	POSSIBLE CAUSES & SOLUTIONS TO PROBLEM
	<ul style="list-style-type: none"> • Long pulse on TRG would activate the Autoclose override feature. • Faulty IR Beam input. • Intermittent power loss, check for low voltages with procedure A: Low battery voltage condition. • If the problem is still not solved, the CP75 main controller might be faulty.
8 Gate opens to pedestrian and closes	<ul style="list-style-type: none"> • Intermittent fault on PED (pedestrian) input. Check wiring, and key switch operation. B: False collision detection. • If the problem is still not solved, the CP75 main controller might be faulty.
9 Gate takes a few seconds before it opens to pedestrian	<ul style="list-style-type: none"> • By default the motor would delay opening to pedestrian for 2 seconds. This time can be changed or removed by changing the value of the PREFLASH TIME feature (Feature 11)
10 Gate opens to pedestrian & stays there	<ul style="list-style-type: none"> • There is a continuous PED signal, the PED light will be on continuously. (The PED light & signal must turn on momentarily for the gate to close after a pedestrian signal.) Check for latching Receiver, or a faulty key switch. • If the problem is still not solved, the CP75 main controller might be faulty.
11 Slave motor moves slower than the master gate	<ul style="list-style-type: none"> • The slave motor wires are too thin. • Either of the Master or Slave motors were not installed on the recommended positions.
12 Gate opens from the intercom but not from the receiver	<p>The fault is with the receiver.</p> <ul style="list-style-type: none"> • Check the wiring between the receiver and control card. • Check that the receiver has power. If not, check the 3A Auxiliary fuse on the main controller. (NB. remove fuse before measuring.) • The receiver could be faulty.

PROBLEM	POSSIBLE CAUSES & SOLUTIONS TO PROBLEM
<p>A Low Battery Voltage Condition (STATUS light flashes 3 times)</p>	<p>(If the battery voltage is less than 10.5V, the motor would not operate at all. For any other voltage, the battery could still be the cause of the problem.</p> <ul style="list-style-type: none"> • Check that the power is turned ON, by first disconnecting the battery and then to check that the green CHARGE light is ON. If it is OFF, then power is not connected to the charger or the power pack. • Check that the power source link is in the STD position when using the CP84E charger, and in the PSUx (10A power pack) driven installations. • Check the condition of the battery leads, terminals and connectors. Look for and correct all loose connections and signs of corrosion. • The battery might be discharged. Measure the battery voltage with the charger connected, if the voltage is below 12.5V then the battery is discharged. The number of opening cycles per hour may be excessive, thus discharging the battery. Charge the battery, or fit a 10A power pack if required. • Charger might be faulty. Disconnect the battery, and measure the voltage on the battery leads. It must be between 13.6V and 13.8V, if not replace the charger. • Battery might be old, and might have to be replaced. If in doubt test as follows: <ul style="list-style-type: none"> ◦ Check that the battery is charged, by ensuring that the battery voltage is above 13.5V with the charger connected. (If the battery is in a good condition it would probably pass the test without being fully charged) ◦ Disconnect the charger from the battery ◦ Remove the DC Motor leads from the DC Controller ◦ Apply the DC motor leads directly to the battery, while measuring the battery voltage. WARNING: First make sure that the moving gate will not pose any danger. ◦ If the gate does not move, the battery or motor could be faulty. ◦ If the battery voltage remains unchanged, then the motor is faulty and must be serviced. If the battery voltage drops to below 11,5V then the battery must be replaced. <p>(Before replacing the battery, measure the charging voltage on the battery leads with the battery disconnected. It must be between 13.6V and 13.8V, if not, replace the charger.)</p>

PROBLEM	POSSIBLE CAUSES & SOLUTIONS TO PROBLEM
<p>B False Collision Detection (STATUS light could flash four times to indicate that number of collisions have exceeded COLLISION COUNTER feature value. Wait 60 seconds, or remove & reapply all power to reset operation.)</p>	<p>To determine which is the faulty gate in a double swing system, activate the gates. Both gates will stop and reverse on closing, but only the faulty gate will stop when opening.</p> <p>For both MASTER and SLAVE motors: (Only the offending gate's components need to be inspected)</p> <ul style="list-style-type: none"> • Check for tight hinges, unbalanced gate, or something physically obstructing the gate. Activate the manual override and move the gates to check for ease of operation. • For SLAVE motor, check the wiring of S1, S2, S3 and the 2 motor wires for continuity and short circuits. Look for moisture on any joints and correct all loose connections and signs of corrosion. (Joints should be soldered together to ensure a reliable joint.) • Check for ants and dirt in and around the DOSS sensor. • Check the DC motor wires for loose connections. • Check contact of the fuses with the fuse holder on CP75 (main controller). • Check that the sensor wire harness is securely plugged into the CP75 (master controller) or CP75A (slave board) and into the DOSS sensor. • Check that the DOSS sensor is securely clipped into the housing. • If the problem is not solved replace the DOSS sensor (CP75B), then the Slave card (CP75A), and main controller (CP75). <p>Note:</p> <p>Orange Wire = Encoder and Purple Wire = Origin</p>

Procedure to Programme Controller Back to Factory Default Settings

1. Remove all power (Power supply and battery).
2. Fit the "SET" link.
3. Connect "PED" and "FRX" to "COM".
4. Reconnect all power. (L1 AND L2 will illuminate).
5. Remove all power (Battery and power supply).
6. Remove the "SET" link and disconnect "PED" and "FRX" from "COM".
7. The card is now programmed to default settings as shown in table 2 (see page 47) (Gate end points are not affected).

Manual Release Mechanism

The manual release mechanism is used to disengage the output shaft from the motor, thus making it possible to open or close the gates manually without turning the motor or any other internal parts.

Normal Operation

1. Flip over the controller enclosure. Open the override dust cover as shown in Fig. 31.
2. Insert the 6mm Allen key supplied into the release mechanism (Fig 25).
3. Turn the Allen key **clockwise** to **release** the mechanism as shown in Fig 25.
or
Turn the Allen key **counter clockwise** to **engage** the release mechanism.
4. Remove the allen key.
5. Close the override dust cover.

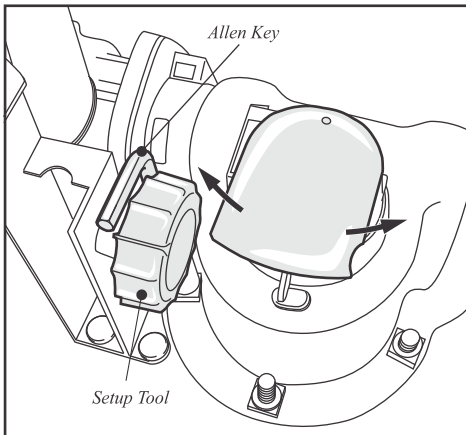

Figure 31 Manual Release Mechanism

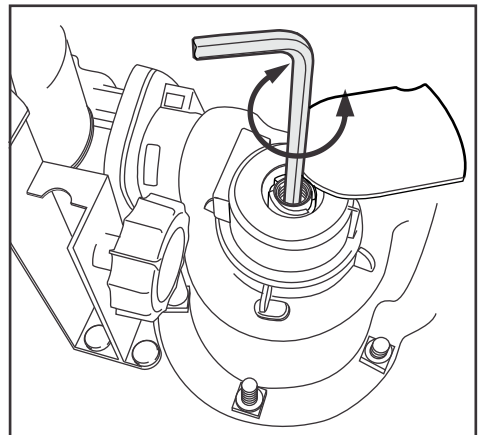
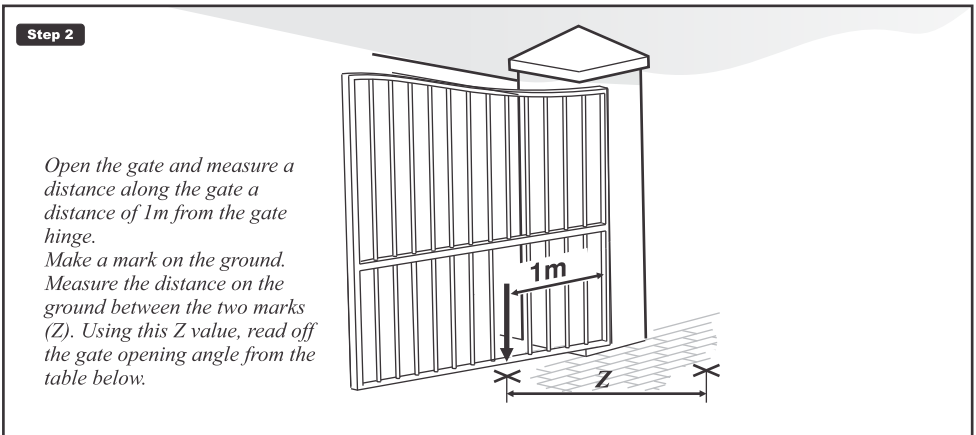
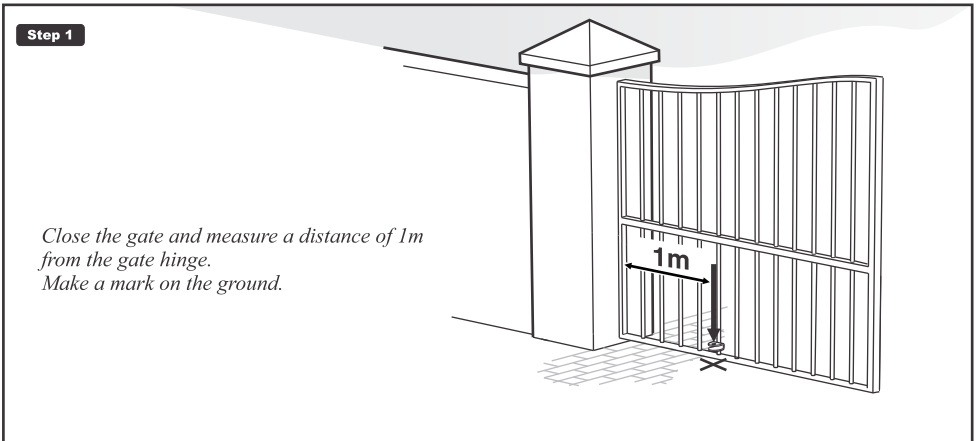

Figure 32 Manual Release Operation



Determine Gate Swing Angle

Use this procedure to accurately determine the gate opening angle:



Step 3	GATE SWING ANGLE	VALUE Z FROM...	...TO
	60 Degrees	1 000mm	1 075mm
	70 Degrees	1 075mm	1 218mm
	80 Degrees	1 218mm	1 351mm
	90 Degrees	1 351mm	1 475mm
	100 Degrees	1 474mm	1 587mm
	110 Degrees	1 587mm	1 687mm
	120 Degrees	1 687mm	1 732mm

Description of Terminal Functions

MASTER	The master motor is connected to these terminals. If the master motor direction is incorrect swap around the wires connected to these terminals.
SLAVE	The slave motor (in dual swing gate applications) is connected to these terminals. As with MASTER, swap the connected wires around for motor direction reversal.
COM	The battery/power supply negative terminal. All trigger signals etc. have their return path to one of the COM terminals.
LIGHT	These two terminals provide a normally open potential free contact which is generally used to switch on a pillar light (courtesy light). It can also be used for other purposes if required.
12V	Provides a +12V DC supply for auxiliary equipment such as a radio receiver, photo cells etc. It is linked directly to the battery positive via a 3A fast blow fuse (see page 47).
TRG	A momentary, normally-open trigger device such as relay, pushbutton etc. connected between TRG and COM will cause the gate to trigger open/closed. Connect multiple trigger devices in parallel (Refer to the section MODE OF OPERATION on page 32).
IRB	The signal from the infrared beam (IRB) (photo cell), safety edge, loop or other safety device. This prevents the gate from closing when the normally-closed contact between IRB and COM is open. For multiple safety devices wire all contacts in series.  NB: If no safety devices are fitted ensure a wire link is fitted between IRB and COM. If Autoclose is selected the time will be reset to the selected value when the device is tripped.
FRX	A momentary normally-open contact from a device such as a free exit inductive loop detector (or photo cell or pushbutton) which causes a gate which is closed or closing to open or re-open. If the gate is open or opening the signal has no effect other than to reset the Autoclose timer (if selected). Free exit (FRX) will never initiate a closing cycle. If only the FRX input is used, the Autoclose must be turned on alternatively the TRG input used to close the gate.
LED	An output terminal which provides a low current, (approx. 4.5V DC, 20mA) drive to an LED which can be used to indicate the gate status remotely. If more than three LED's are required it is necessary to fit a LED driver card (consult Centurion Systems (Pty) Ltd for details).
PED	A momentary normally-open contact from a pedestrian key switch, pushbutton, keypad, radio receiver etc which will cause the MASTER gate only, to open to the limited pedestrian open position. The gate opens only after the adjustable pre-flash time (default - 2 seconds). If the contact is held closed the Autoclose is suspended until the contact reopens.
LCK	If the latched normally-closed contact between LCK and COM is held open, all triggers which would normally cause a closed gate to open (e.g. TRG, PED, FRX) will be inhibited. If the gate is open, opening or closing and the LCK contact is opened the gate will continue to respond until such time as the gate is in the fully closed position.  NB: If the LCK function is not required a link must be fitted between LCK and COM.
SET	This terminal has two functions: <ol style="list-style-type: none">1. If SET is linked to COM with no power present to the controller and power is then applied, the controller will be put into PROGRAMME mode.2. If SET is linked to COM when power is already applied, this action will cause the pillar light relay to energise. A momentary contact causes the relay to energize for a period of time as defined for the courtesy light timer. If the contact is made for a period exceeding 3 seconds the pillar light relay will energize and remain energized indefinitely until a new momentary contact is given.
SOL	A solenoid strike lock is connected between SOL and 12V. Each time the gate triggers to open (or close) the SOL terminal switches to COM thus energizing the solenoid. The time that the SOL terminal remains switched to com is set using FEATURE 14. The maximum current draw is 2A.
SS1 to SS3	Limit switch contacts from the slave interface PCB.

LED Indicator Lights

The controller is fitted with diagnostic lights (LEDs) that assist with the set-up and maintenance of the gate. Table 1 provides a description and purpose of the indicator lights. Refer to page 46 for location.

During Normal Operation				
NAME	COLOUR	ON	OFF	REMARKS
STATUS (During normal operation)	Red	Gate fully open	Gate fully closed	1 Flash/sec - Pillar light on permanently 2 Flashes/sec - Charging failure 3 Flashes/sec - Battery low detection 4 Flashes/sec - Collision detector operated 5 Flashes/sec - Microprocessor reset
L1	Red			Master origin diagnostic (Changes state to indicate origin status)
L2	Red			Slave origin diagnostic (Changes state to indicate origin status)
CHARGER ON	Green	Battery charging	No charge voltage present.	
TRG	Red	Signal present	No signal	N/A
IRB	Green	Safeties clear	Safeties obstructed	N/A
FRX	Red	Signal present	No signal	N/A
PED	Red	Signal present	No signal	N/A
LCK	Green	System ready to operate	System locked	N/A
SET	Red	Signal present	No signal	N/A
During Programming Mode				
STATUS	Red			The number of flashes correspond to the STATUS or COUNT value being set.
L1	Red	If LED2 also on, system reset to factory default.		The number of flashes corresponds with the FEATURE number being selected
L2	Red	System in programme mode. If L1 also on, system reset to factory default.		

Table 1 LED Indicator Light Description & Purpose

CP75 Controller Functions

FEATURE		STATUS or COUNT		
DESCRIPTION	FEATURE NUMBER	STATUS VALUE	COUNT VALUE	DESCRIPTION
Gate Limit Settings	1	-	-	See detailed instructions on page 29
Autoclose	2	1	-	ON
		2	-	OFF (Default)
Autoclose Time	3	-	1 Flash = 1 second	15 seconds (Default)
Mode of Operation	4	1	-	STANDARD (Default)
		2	-	CONDOMINIUM
		3	-	PIRAC
		4	-	REVERSING
Pedestrian Autoclose	5	-	1 Flash = 1 second	5 seconds (Default)
Courtesy Light	6	-	1 Flash = 10 seconds	120 seconds (Default)
Collision Sensitivity	7	1	-	HIGH (Default)
		2	-	MEDIUM
		3	-	LOW
Autoclose Override	8	-	1 Flash = 1 second	3 second (Default)
Positive Close Mode	9	1	-	ON
		2	-	OFF (Default)
Preflashing	10	1	-	MODE 1
		2	-	MODE 2
		3	-	MODE 3
		4	-	OFF (Default)
Preflash Time	11	-	1 Flash = 1 second	2 seconds (Default)
Collision Counter	12	-	1 Flash = 1 count	4 counts (Default)
Leaf Delay Select	13	1	-	Delay on slave opening
		2	-	Delay on master closing
		3	-	Delay on slave opening & master closing
		4	-	Delay off (Default)
Leaf delay time / Solenoid Strike Time	14	-	1 Flash = 1 second	2 seconds (Default)

Table 2 Controller Functions Menus and Submenus

CP75 Controller Connections

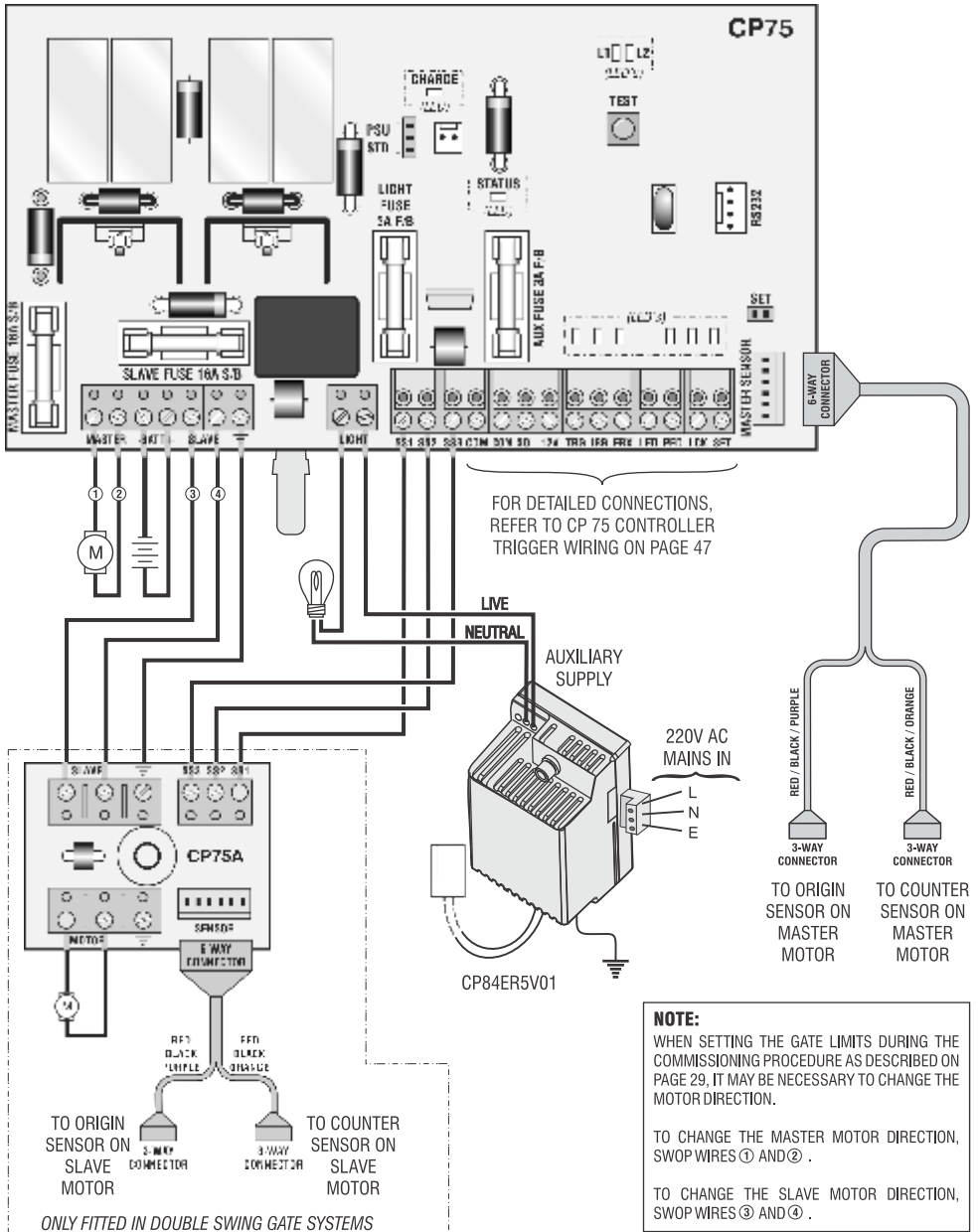

CP75 Trigger Connections

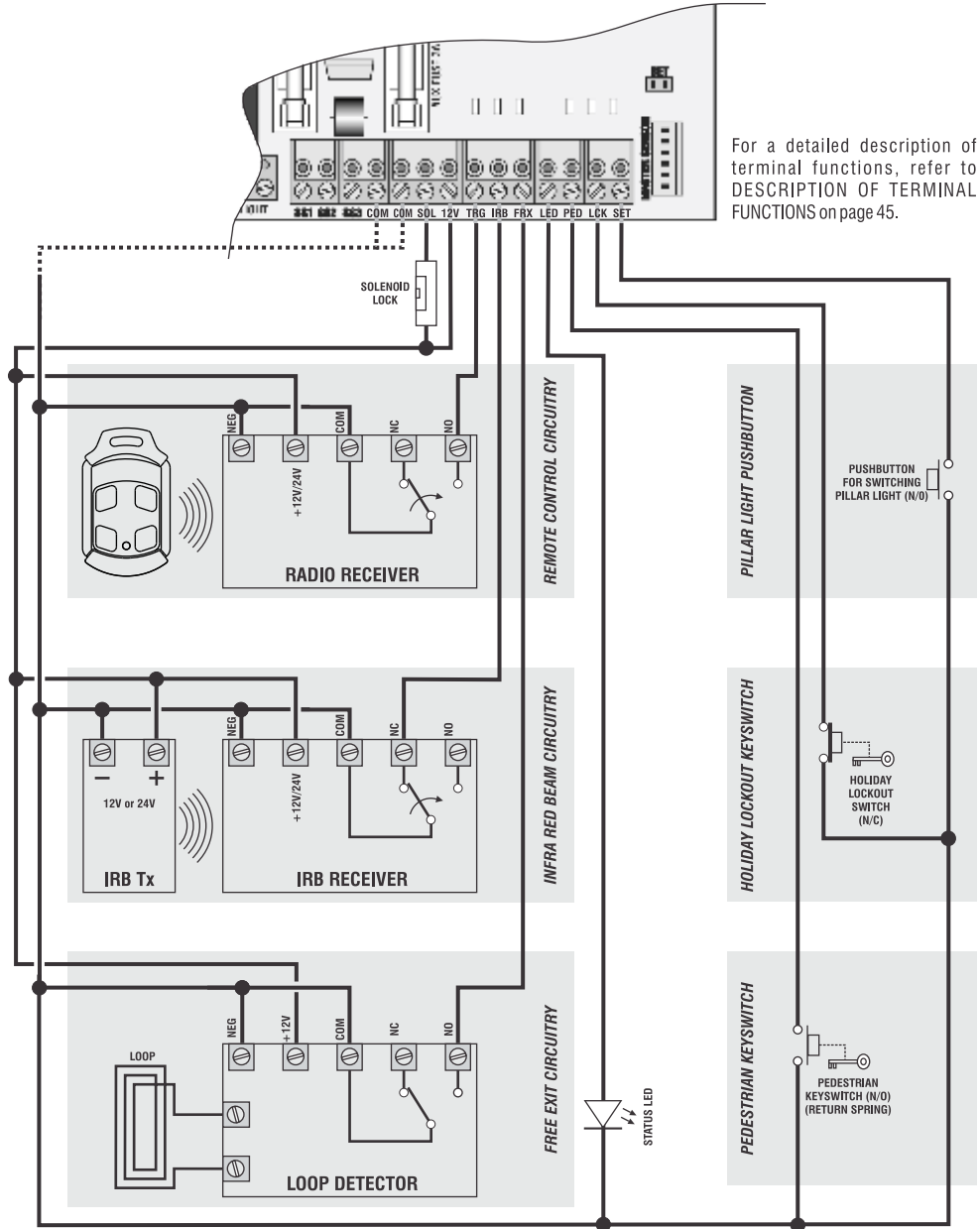

For a detailed description of terminal functions, refer to DESCRIPTION OF TERMINAL FUNCTIONS on page 45.

CP84ER5V01 Charger Connection

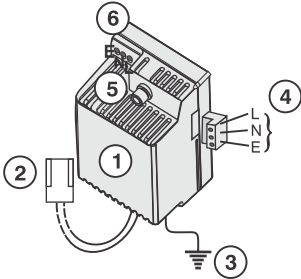

- 1 CP84ER5V01 Charger Transformer
- 2 14.2V DC charger plug to CP75 controller
- 3 Lightning Earth Point
- 4 220V AC, 1Ø, Mains Supply for CP84ER5V01 using removable connectors
- 5 Mains fuse (250mA, size 5 x 20mm)
- 6 Auxiliary Mains Connector, 220V AC

PSUx Power Connection

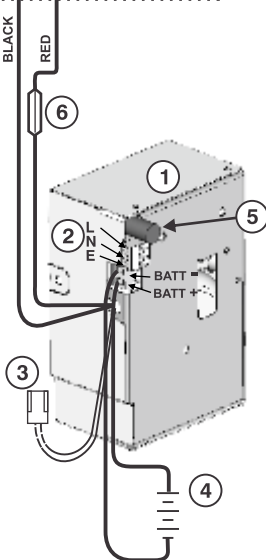
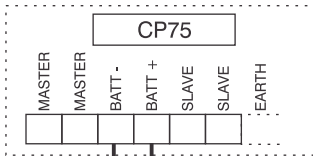

- 1 PSUx - Power Supply Unit
- 2 220V AC, 1Ø, Mains Supply for CP84E using removable connectors
- 3 DC charger plug to CP75 controller
- 4 12V DC lead acid battery (Amp/hour rating to suit)
- 5 Mains Fuse - 250mA size - 5x20mm
- 6 16A Slow-blow fuse



Ensure that the power source link is set to PSU in Fig. 24 on page 27

Installation Handover

Once the installation has been successfully completed and tested, it is important for the installer to explain the operation and safety requirements of the system.

NEVER ASSUME THE USER KNOWS HOW TO SAFELY OPERATE AN AUTOMATED GATE. Even if the user has used one before, it does not mean he knows how to **SAFELY** operate it. Make sure that the user fully understands the following safety requirements before finally handing over the site.

Ensure that the user fully understands:

- How to operate the manual release mechanism. (By demonstration)
- How the obstruction detection and all other safety features work. (By demonstration)
- All the safety considerations associated with operating an automated gate, and that he understands that he is responsible for explaining these safety instructions to all other users of the automated system:
 1. Do not activate your gate opener unless you can see it and can determine that its area of travel is clear of people pets, or other obstructions.
 2. **NO ONE MAY CROSS THE PATH OF A MOVING GATE.** Always keep people and objects away from the gate and its area of travel.
 3. **NEVER LET CHILDREN OPERATE OR PLAY WITH THE GATE CONTROLS**, and do not allow children or pets near the gate area.
 4. Be careful with moving parts and avoid close proximity to areas where fingers or hands could be pinched.
 5. Secure all easily accessed gate opener controls in order to prevent unauthorized use of the gate.
 6. Keep the automated gate system properly maintained, and ensure that all working areas are free of debris and other effects that could affect the gate operation and safety.
 7. On a monthly basis, check the obstruction detection system and safety devices for correct operation.
 8. All repair, and service work to this product must be done by a suitably qualified person.
 9. This product was designed and built strictly for the use indicated in this documentation. Any other use, not expressly indicated here, could compromise the good condition/operation of the product an/or be a source of danger.
 10. Centurion Systems (Pty) Ltd does not accept any liability caused by improper use of the product, or for use other than that for which the automated system was intended.
 11. Ensure that the customer is in possession of the User Guide and also complete the installation details in the back of the User Guide.

Installation Details

Installation Date:

Installer's Name:

Installer's Address:

Installer's Telephone Number: Installation Checked By:









Head Office: +27 11 699 2400

Technical Support: +27 11 699 2481
from 07h00 to 18h00 (GMT+2)



0.07.B.0030

www.centsys.com.au