

D2 Turbo and D2 Turbo Low-Voltage Installation Manual



D2 unlocks turn right 90 degrees
D5 unlocks turning left



Company Profile



1986

1990

1995

1999

Today

In-house R&D development team



100% testing of products

Manufacture to international quality standard ISO 9001:2008



After-sales multi-language Technical Support from 07h00 to 18h00 UTC+2 Monday to Friday



Sales and technical support to Africa, Europe, Asia, the Americas, Australia and the Pacific

Centurion Systems (Pty) Ltd reserves the right to make changes to the products described in this manual without notice and without obligation to notify any persons of any such revisions or changes. Additionally, **Centurion Systems (Pty) Ltd** makes no representations or warranties with respect to this manual. No part of this document may be copied, stored in a retrieval system or transmitted in any form or by any means electronic, mechanical, optical or photographic, without the express prior written consent of **Centurion Systems (Pty) Ltd**.



Contents

FAST TRACK	Mechanical Setup	page 5
	Electrical Setup	page 6
	Commissioning and Handover	page 6
<hr/>		
SAFETY FIRST	IMPORTANT SAFETY INSTRUCTIONS	page 7
	Glossary of Terms	page 9
1.	General Description	page 11
2.	Icons Used in this Manual	page 12
3.	Specifications	page 13
3.1.	Physical Dimensions	page 13
3.2.	Technical Specifications	page 13
4.	Product Identification	page 15
5.	Required Tools and Equipment	page 16
6.	D2 Turbo Low-voltage Site Considerations	page 17
7.	Preparation of Site	page 18
8.	Cabling Requirements	page 21
9.	Lubrication	page 22
10.	Operator Installation	page 23
10.1.	Foundation plate installation	page 25
10.2.	Route Cables and Secure Foundation Plate	page 31
10.3.	Mount the gearbox	page 31
10.4.	Mount the rack	page 34
10.5.	Mount the origin marker	page 38
10.6.	Apply warning decal	page 41
11.	Electrical Setup	page 42
11.1.	Connect all Wiring	page 42
11.2.	Wiring Diagram for Closing Safety Beams/ Photocells	page 43
11.3.	Wiring Diagram for Opening Safety Beams/ Photocells	page 44
11.4.	Wiring Diagram for External Radio Receiver	page 45

11.5.	Wiring Diagram for Other Inputs	page 46
11.6.	Wiring Diagram for Pillar Light to D2 Turbo	page 47
11.7.	Wiring Diagram for Pillar Light to D2 Turbo Low-Voltage	page 48
11.8.	Wiring Diagram for Solar Panel to D2 Turbo	page 49
11.9.	Wiring Diagram for Solar Panel to D2 Turbo Low-Voltage	page 50
11.10.	Mains Supply and Battery Connections	page 51
11.11.	Earthing for Effective Lightning Protection	page 52
12.	Commissioning the System	page 53
13.	Features and Functions	page 55
14.	Customising the Features and Functions	page 67
15.	Description of Terminal Functions	page 86
16.	Diagnostics	page 88
17.	Troubleshooting	page 89
18.	Manual Operation	page 93
19.	Additional Features	page 94
20.	Basic Maintenance	page 95
21.	Servicing the Operator	page 96
22.	24 Month Carry-in Product Warranty	page 97
23.	Installation Handover	page 99

FAST TRACK Mechanical Setup

These abbreviated instructions are for the experienced installer who needs a checklist to get a standard installation up and running in the minimum of time.

Detailed installation features and functions are referred to later in this manual.

STEP 1	Gather Required Tools and Equipment	page 16
STEP 2	Heed Necessary Site Considerations	page 17
STEP 3	Cabling requirements	page 21
STEP 4	Lubrication	page 22
STEP 5	Operator installation	page 23
STEP 6	Foundation plate installation	page 25
STEP 7	Cabling and Wiring	page 31
STEP 8	Mount Gearbox	page 31
STEP 9	Mount the Rack	page 34

Electrical Setup

STEP 10

Connect all wiring

page 42

STEP 11

Set the gate limits

page 53

STEP 12

Set additional features

page 67

Commissioning & Handover

STEP 13

Carry out a Professional Handover to Client

page 99

IMPORTANT SAFETY INSTRUCTIONS

ATTENTION

To ensure the safety of people and possessions, it is important that you read all the following instructions.

Incorrect installation or incorrect use of the product could cause serious harm to people.



The installer, being either professional or DIY, is the last person on the site who can ensure that the operator is safely installed, and that the whole system can be operated safely.

Warnings for the Installer

CAREFULLY READ AND FOLLOW ALL INSTRUCTIONS before beginning to install the product.

- All installation, repair, and service work to this product must be carried out by a suitably qualified person
- This appliance is not intended for use by persons (including children) with reduced physical, sensory or mental capabilities, or lack of experience and knowledge, unless they have been given supervision or instruction concerning use of the appliance by a person responsible for their safety
- Do not activate your gate unless you can see it and can determine that its area of travel is clear of people, pets, or other obstructions
- NO ONE MAY CROSS THE PATH OF A MOVING GATE.
- Always keep people and objects away from the gate and its area of travel
- NEVER LET CHILDREN OPERATE OR PLAY WITH THE GATE CONTROLS
- Secure all easily-accessed gate opener controls in order to prevent unauthorised use of the gate
- Do not in any way modify the components of the automated system
- Do not install the equipment in an explosive atmosphere: the presence of flammable gasses or fumes is a serious danger to safety
- Before attempting any work on the system, cut electrical power to the operator and disconnect the batteries
- The mains power supply of the automated system must be fitted with an all-pole switch with contact opening
- Make sure that an earth leakage circuit breaker with a threshold of 30mA is fitted upstream of the system
- Never short-circuit the battery and do not try to recharge the batteries with power supply units other than that supplied with the product, or by Centurion Systems (Pty) Ltd

- Make sure that the earthing system is correctly constructed, and that all metal parts of the system are suitably earthed
- Safety devices must be fitted to the installation to guard against mechanical movement risks such as crushing, dragging and shearing
- It is recommended that at least one warning indicator light be fitted to every system
- Always fit the warning signs visibly to the inside and outside of the gate
- The installer must explain and demonstrate the manual operation of the gate in case of an emergency, and must hand the User Guide/Warnings over to the user
- Explain these safety instructions to all persons authorised to use this gate, and be sure that they understand the hazards associated with automated gates
- Do not leave packing materials (plastic, polystyrene, etc.) within reach of children as such materials are potential sources of danger
- Dispose of all waste products like packing materials, worn- out batteries, etc., according to local regulations
- Always check the obstruction detection system, and safety devices for correct operation
- Neither Centurion Systems (Pty) Ltd, nor any of its subsidiaries, accepts any liability caused by improper use of the product, or for use other than that for which the automated system was intended
- This product was designed and built strictly for the use indicated in this documentation. Any other use, not expressly indicated here, could compromise the service life/operation of the product and/or be a source of danger

Glossary of Terms

- **DOSS:** Digital Origin Seeking System. An opto-electronic system that counts pulses in order to determine the position of the gate and the distance that it needs to travel to its respective endstops
- **IRBO:** Opening infrared Safety Beams. If the opening beams are interrupted while the gate is in the closed position, it will prevent the gate from opening. If they are interrupted while the gate is travelling in the open direction, it will stop and close the gate. It will have no effect upon a closing gate
- **IRBC:** Closing infrared Safety Beams. If the closing beams are interrupted while the gate is in the open position, it will prevent the gate from closing. If they are interrupted while the gate is closing, it will stop and open the gate. It will have no effect upon an opening gate
- **PIRAC Mode:** Passive infrared Autoclose Mode. This feature allows the gate to close automatically as soon as a vehicle or pedestrian has passed through the closing beam. This security feature ensures that the gate stays open for the minimum amount of time possible, thus maximising security at the entrance

Declaration of Conformity

Manufacturer

Centurion Systems (Pty) Ltd
 Unit 13 Production Park
 Intersection of Newmarket Road and Epsom Avenue
 North Riding
 Gauteng
 South Africa

Declares that the product

Product name: D2 Turbo/D2 Turbo Low-Voltage Sliding gate operator.

Conforms with the following specifications

Emissions: CISPR 11 CLASS A - Radiated and conducted Interference field strength (emission tests) - 150KHz TO 6GHz

Immunity: IEC 61000-4-2 - Electrostatic discharge
 IEC 61000-4-3 - Radiated immunity - 80MHz TO 1000MHz
 IEC 61000-4-4 - Electrical fast transients/burst
 IEC 61000-4-5 - Surges
 IEC 61000-4-6 - Conducted immunity - 150KHz TO 80MHz
 IEC 61000-4-11- Voltage dips and interruption

Standard to which conformity is declared

IEC 60335-1:2006	Safety
IEC 61000-6-4:2006	Emissions
IEC 61000-6-2:2005	Immunity

Signed at North Riding, South Africa on April 14, 2010



Ian Rozowsky
 Research & Development Director

1. General Description

The D2 Turbo is designed to open and close domestic sliding gates weighing up to 250kg. The gearbox, moulded from a high-tech engineering polymer not only looks good, but is corrosion-free and guarantees that even if you live on the coast, your D2 Turbo will just keep on going. A robust steel pinion ensures that your D2 Turbo can easily be retrofitted on sites with existing steel rack and will deliver years of reliable service.

The D2 Turbo Low-Voltage is a cost-effective domestic sliding gate motor for gates weighing up to 250kg. Its logic controller and onboard charger require only a low-voltage AC or DC input, which means there is no need for costly high-voltage cable runs or expensive isolators.

The integral 12V 5Ah battery (charged by an internal charger) comes with full battery backup and advanced lightning protection so you can always get in – even when the power is out. For increased power capacity you can install a larger, 7Ah battery (your D2 Turbo was designed to cater for this), or you can even use a solar panel to power it (See the section on Solar Panels, for more details about solar charging).

Advanced features of the D2 Turbo logic controller:

The D2 Turbo has various useful features and functions, all easily-accessible from a user-friendly dial-based setup system:

- Opening and closing safety beam inputs with beam circuit functional test¹
- High-security cleared-beam Autoclose in conjunction with safety beams (PIRAC)¹
- Multiple Modes of Operation: Standard Mode, Open only Mode (multi-user), Reversing Mode, and two Pre-flashing Modes
- Automatic closing with adjustable time delay, and pushbutton override
- Remote gate-status indicator (gate position, power failure, low battery, multiple collision detection and Pillar Light status indication)²
- Pedestrian Opening³ (with adjustable Autoclose time)
- Holiday Lockout³
- Courtesy/Pillar-Light timer (fixed duration), with pre-delays and two Pre-flashing Modes⁴
- Selectable gate speed modes - Low Speed/High Speed (High Speed is the default)
- Positive Close Mode (e.g. ensure activation of electric fence contact switch)
- Onboard multichannel code-hopping receiver with the ability to learn transmitter buttons to specific functions (e.g. Gate trigger, Pedestrian Opening, Holiday Lockout)

1. Infrared Safety Beams or equivalent detection device must be fitted

2. Remote LED must be fitted

3. Onboard receiver must be used or external access control device such as a keypad or keyswitch that must be fitted

4. Pillar Lights/Pre-flash warning light must be fitted

2. Icons Used in this Manual



This icon indicates tips and other information that could be useful during the installation.



This icon denotes variations and other aspects that should be considered during installation.



This icon indicates warning, caution or attention! Please take special note of critical aspects that MUST be adhered to in order to prevent injury.

3. Specifications

3.1. Physical Dimensions



FIGURE 1. OVERALL DIMENSIONS

3.1. Technical specifications

	D2 Turbo	D2 Turbo Low-Voltage		
Supply Voltage	90V - 240V AC ± 10%, 50Hz ¹	10V - 20V AC ¹ 10V - 28V DC ¹		
Battery Charger Amperage Output (dependant on PSU input voltage)	Voltage output: 13.76V DC			
	90V AC Input	1A Output	10V AC Input	400mA Output
			20V AC Input	1A Output
	240V AC Onput	1.2A Output	10V DC Input	200mA Output
20V DC Input			1A Outpu	
Motor voltage	12V DC			
Motor Power Supply	Battery-driven (Standard Capacity - 12V 5Ah) ²			
Current Consumption (mains)	70mA	NA		

	D2 Turbo	D2 Turbo Low-Voltage
Current Consumption (motor at rated load)	8A	
Operator Push Force - Starting	18kgf	
Operator Push Force - Rated	9kgf	
Gate Mass - Maximum	250kg	
Gate Length - Maximum	20m	
Gate Speed (Varies with Load) ³	24m/min	
Manual Override	Lockable with Key Release	
Life Expectancy of Electric Motor	Ten Years (based on ten operations per day)	
Duty Cycle - Mains Present ^{4,5}	50%	
Operations in Standby with 5Ah Battery		
Half Day ⁶	30	
Full Day ⁶	15	
Collision Sensing	Electronic	
Operating Temperature Range	-15°C to +50°C	
Onboard Receiver Type	Code-hopping Multichannel Receiver with Selective add and Delete	
Receiver Code Storage Capacity	32 Transmitter Buttons	
Receiver Frequency	433.92MHz	
Degree of Protection	IP44	
Mass of Unit Packed (with standard kit, but excl. rack and battery)	4.83kg	
Packaging Dimensions (with standard kit, but excl. rack and battery)	255mm wide x 188mm deep x 333mm high	

TABLE 1

1. Can operate off a solar supply, consult your local dealer for assistance
2. Can increase battery capacity to 7Ah for longer standby times
3. Gate operating speed can be configured to run slower depending on the requirements of individual installations
4. Based on 25°C ambient temperature and unit not in direct sunlight
5. Based on an operator push force of less than 50% of rated
6. Based on four metre gate, excluding infrared Safety Beams

4. Product Identification

Refer to the drawings below, for how to identify your D2 Turbo/D2 Turbo Low-Voltage motor and its parts.

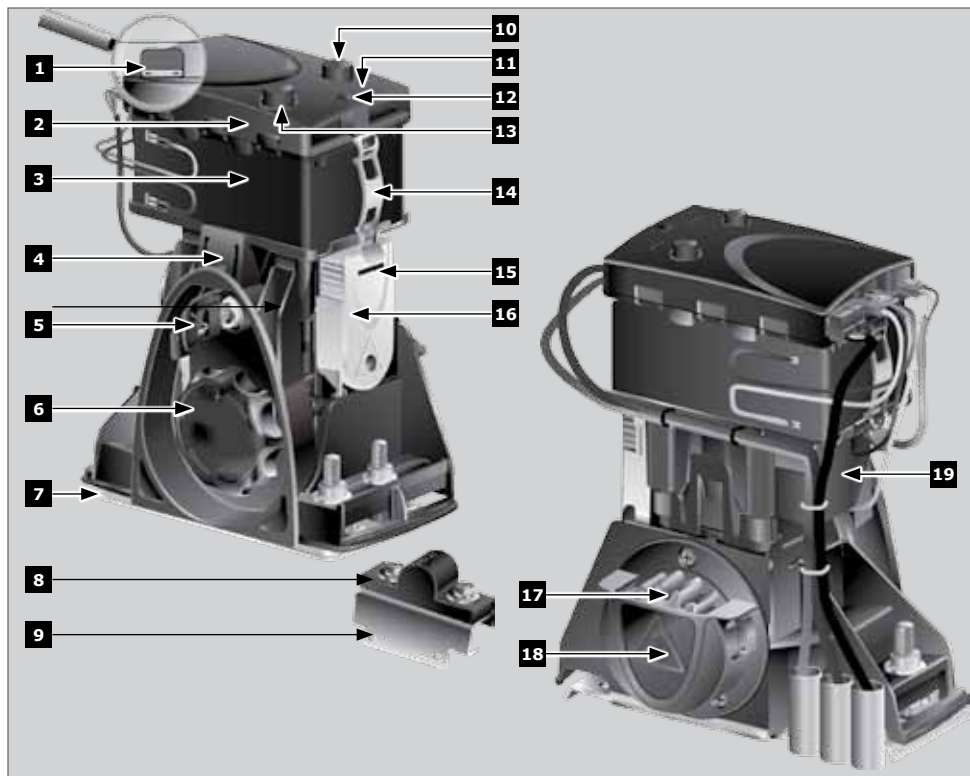

FIGURE 2. PRODUCT IDENTIFICATION

- | | |
|---|--------------------|
| 1. Motor fuse | 11. Status LED |
| 2. D2 Turbo 220V orange controller and D2 Turbo Low-Voltage dark-green controller | 12. Function Dial |
| 3. 12V 7.2Ah or 5Ah battery | 13. Selection knob |
| 4. Motor enclosure unit | 14. Battery strap |
| 5. Camlock cover | 15. Spare fuse |
| 6. Manual Release thumbwheel | 16. Pulley guard |
| 7. Foundation plate | 17. Pinion |
| 8. Gate-mounted origin marker | 18. Pinion guard |
| 9. Origin marker bracket | 19. Motor housing |
| 10. Selection knob | |

5. Required Tools & Equipment



FIGURE 3. REQUIRED TOOLS & EQUIPMENT

6. D2 Turbo Low-voltage Site Considerations

IMPORTANT Site Considerations for the D2 Turbo Low-Voltage

Before you attempt to use your new gate motor for the first time, you should know::

- **At no point must 220V be supplied to the system! This is a low-voltage model and connecting a mains voltage supply that exceeds its maximum specifications will irreparably damage the electronics**
- **No earth terminal is provided for the incoming power, and is not necessary, but the earthing lead must still be grounded to the motor base plate as this serves as lightning protection**
- **The thickness of the cable needed to supply power to the system will depend on the distance between the transformer and the motor, as well as on the output voltage of the transformer used. The table below shows the typical cable thicknesses for corresponding distance and assumes a 16V AC transformer output**

Distance from transformer to operator	Minimum cable thickness required
Up to 20m	1mm ²
20m - 40m	1.5mm ²
40m - 60m	2.5mm ²

7. Preparation of Site



WARNING!

Endstops are mandatory and must be fitted to prevent death or accidental injury should the gate overrun its limit. They are also required to complete the setup procedure.

7.1. Endstops

Fit endstops capable of stopping the gate at rated speed. Refer to specifications at the beginning of this manual for the operating speed

Make $H > h$ to ensure gate will not jump over endstop

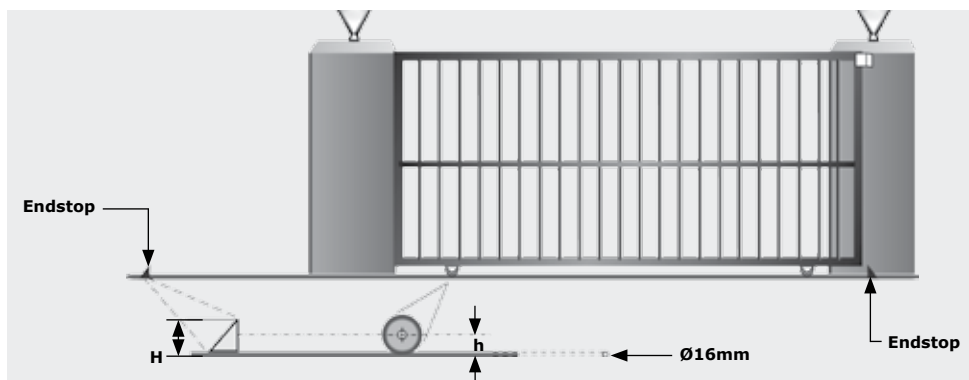

FIGURE 4. FITTING ENDSTOPS

7.2. General Considerations for the Installation

Always recommend the fitment of additional safety equipment such as Safety Edges and Safety Beams/Photocells, for additional protection against entrapment or other mechanical risks.

Check that no pipes or electrical cables are in the way of the intended installation

Check that enough space is available for the gate operator with the gate in the required open position.

Check for loose, sandy soil if installing foundations, as the soil condition may require a larger foundation.

Never fit the operator on the outside of the gate, where the public has access to it.

7.3. Install the gate operator only if:

It will not pose a hazard to the public.

There is sufficient clearance to a roadway and/or public thoroughfares

The installation will meet all municipal and/or local authority requirements once completed.

The gate mass, length and application is within the operator specifications

The gate is in good working order, meaning:

- That it moves freely
- Does not move on its own if left in any position
- It can be installed to have sufficient clearance between moving parts when opening and closing to reduce the risk of personal injury and entrapment

Pushbuttons or keyswitches, when required, can be positioned so that the gate is in line of sight of the operator

7.4. Guide-rollers and anti-lift brackets

Guide-rollers must ensure that the gate is held vertically

For improved safety, fit additional support post to prevent gate from falling over if guide-rollers fail

To prevent unauthorised access fit anti-lift brackets as shown

The gap between the anti-lift bracket and the gate must be less than 5mm



Ensure that the gate cannot be lifted off the motor pinion with the anti-lift bracket fitted.

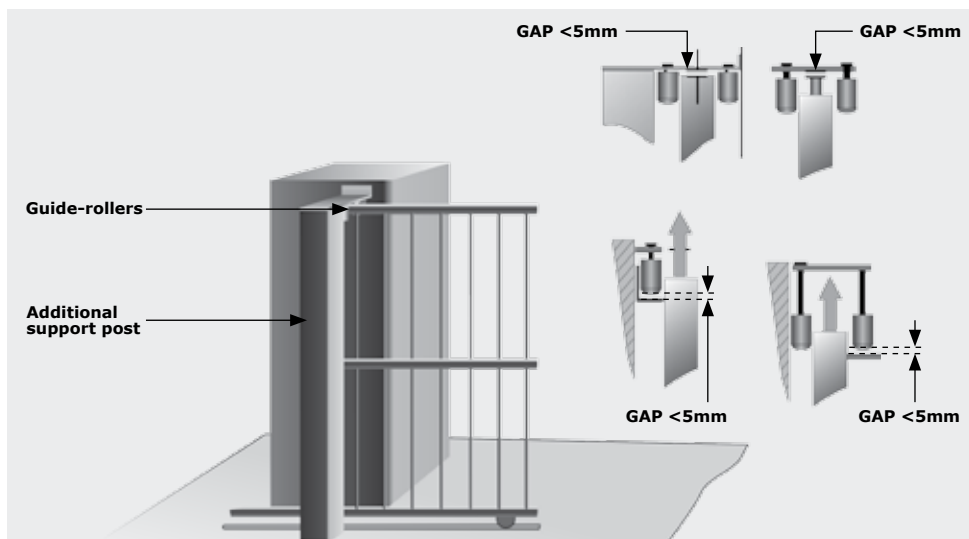

FIGURE 5. FITTING GUIDE-ROLLERS

7.5. Starting and running forces

Test the starting force of the gate as per Figure 6. Use a pull scale to determine the maximum amount of pull force required to get the gate moving

Determine the running force of the gate by continuing to pull on the scale with just sufficient force to keep it running and read off the maximum value in kgf shown on the scale

Where possible determine the gate mass

The warranty will be void if the pull force and/or gate mass exceed the operator specification as below:

- Starting force - 18kgf
- Running (rated) force - 9kgf
- Maximum gate mass - 250kgf

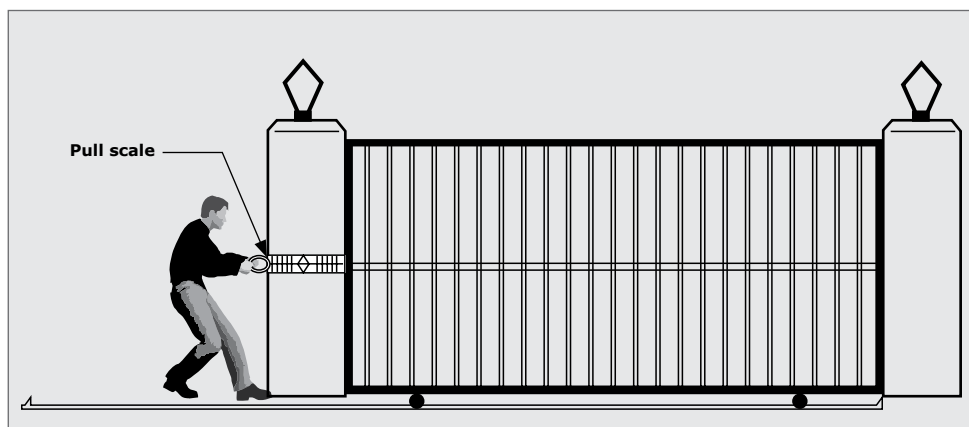

FIGURE 6. STARTING AND RUNNING FORCES

8. Cabling Requirements

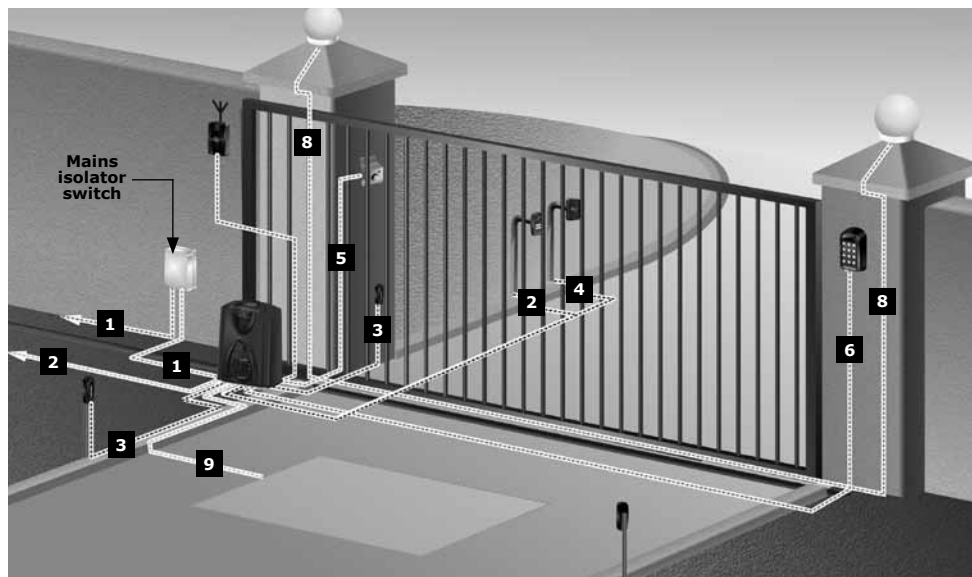

FIGURE 7. CABLING REQUIREMENTS

Legend

1. D2 Turbo: 220V - 240V AC mains cable via double mains isolator switch (3 core LNE 1.5mm² SWA) D2 Turbo Low-Voltage: 10V - 20V AC or 10-28V DC cable via transformer in dwelling¹

Optional Wiring (all cable is multi-stranded):

2. Intercom, cable from control box to dwelling (n1 6 + 6 core 2 0.5mm² multi-stranded) or cable from control box to entry panel (n2 6 0.5mm² multi-stranded)
 3. Infrared Safety Beams (3 core 0.5mm² multi-stranded)
 4. Access control device (3 core 0.5mm² multi-stranded⁴)
 5. Pedestrian keyswitch (2 core 0.5mm² multi-stranded) or
 6. Keypad (3 core 0.5mm² multi-stranded)
 7. External radio receiver (3 core 0.5mm² multi-stranded⁵)
 8. Pillar Lights (3 core LNE SWA², size according to power requirements)
 9. Inductive loop detector for free-exit (1 core 0.5mm² multi-stranded - silicone-coated⁶)
1. Possibly increase cable thickness if Pillar Lights are to be installed
 2. SWA - steel wire armoured. Type of cable must adhere to municipal bylaws and preferably be screened. Screening provides better protection against lightning - earth one end of the screening
 3. Allows for all features such as Pedestrian Opening, Status LED, etc. to be operated from the intercom handset inside the dwelling
 4. Number of cores and type of cable could vary depending on the brand of access control system being used
 5. For optimum range an external radio receiver can be mounted on the wall
 6. Number of cores required by the intercom

9. Lubrication

The gearbox of the D2 Turbo is filled with grease during the assembly process, and the gearset does not have to be lubricated ex-factory.

10. Operator Installation

To ensure operator does not protrude into the driveway, install the foundation plate at least flush with the driveway entrance

Determine a suitable position and vertical height for the operator by considering Figures 8, 9 and 10.



With careful selection of the rack configuration, and operator vertical height, mounting of the rack could in some cases be greatly simplified.



If a theft-resistant cage is required, be sure to leave enough clearance from pillars, etc.

It is typical to mount the rack above the pinion as shown in figures 8A, 9A and 10A for each type of rack considered. However, figures 8B, 9B and 10B show in each case the rack mounted underneath.

Pros of mounting the rack below the pinion

- The rack is more hidden from view
- It provides a very effective anti-lift bracket
- It ensures that as the gate beds in, the rack does not drop onto the pinion, loading the operator unnecessarily

Cons of mounting the rack below the pinion

- Rack teeth face up vertically, potentially collecting dirt
- Custom bracket required to mount origin magnet

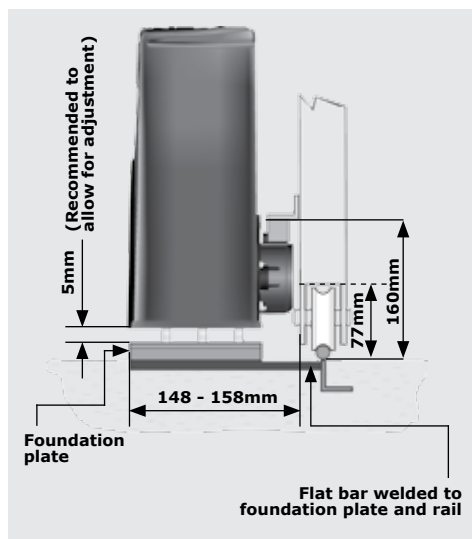

FIGURE 8A. ABOVE PINION - RAZ RACK

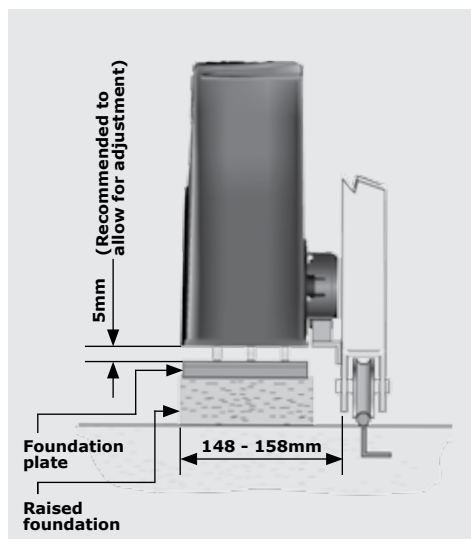

FIGURE 8B. BELOW PINION - RAZ RACK

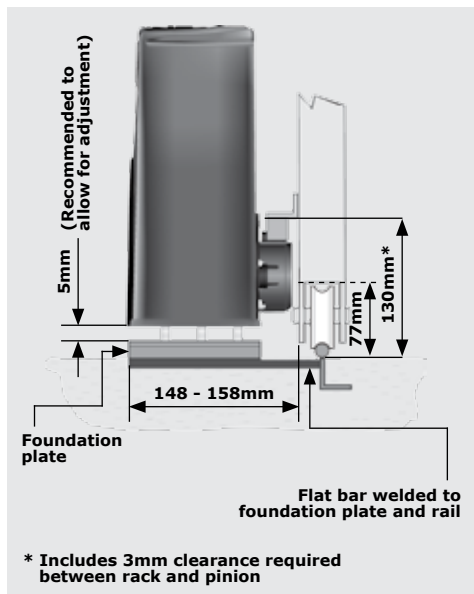

FIGURE 9A. ABOVE PINION - NYLON ANGLE RACK

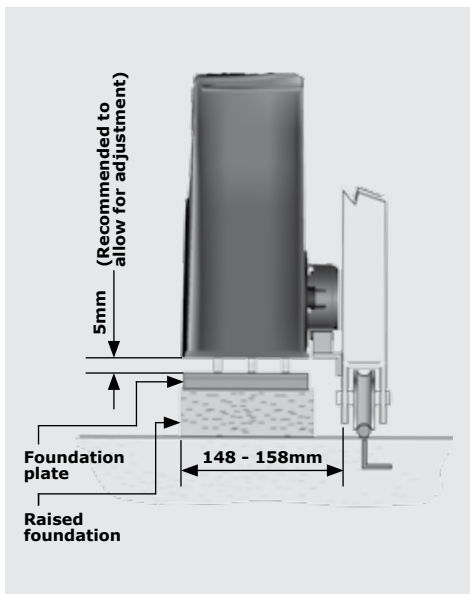

FIGURE 9B. ABOVE PINION - NYLON ANGLE RACK

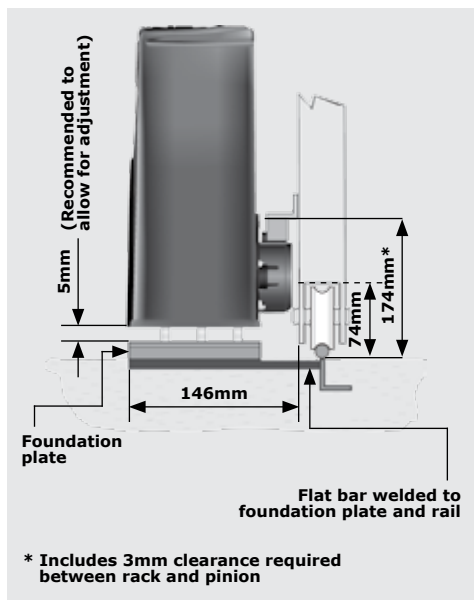

FIGURE 10A. ABOVE PINION - STEEL RACK

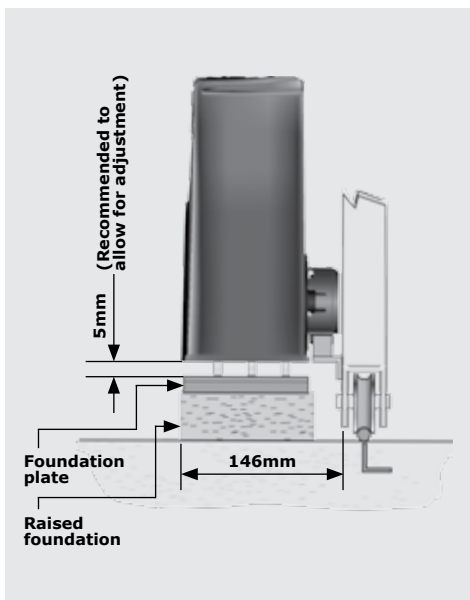

FIGURE 10B. ABOVE PINION - STEEL RACK

10.1. Foundation plate installation



When using a concrete foundation it is recommended that the foundation plate is welded to the rail/track of the gate using short length of flat bar, as in Figure 11. This makes it possible to complete the whole mechanical and electrical installation, without having to wait for the concrete to set. After completing the installation the concrete can be poured and the operator left in the Manual Mode until the concrete has set.

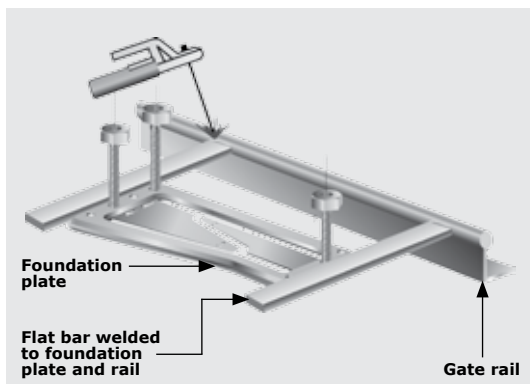

FIGURE 11

The foundation plate can either be set into a concrete foundation, as in Figures 12 to 18, or bolted down onto an existing concrete plinth as shown in Figure 19 and 20. If the D2 Turbo is being used to replace a D3 gate operator, refer to Figures 22 to 27.



FIGURE 12

Option 1: Cast foundation plate into concrete

Bend the anchor brackets outwards as shown in Figure 13.



FIGURE 13

Using a pair of long-nosed pliers, bend the ends of the anchor brackets at a 90° angle.

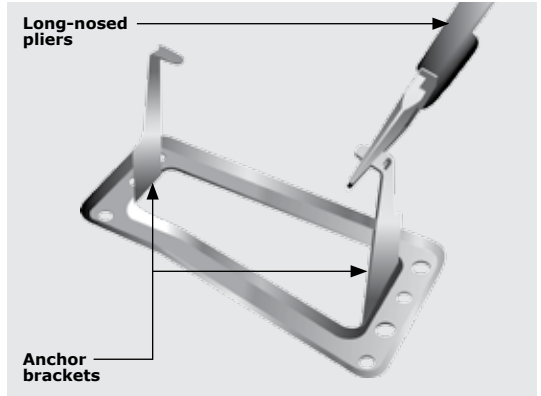

FIGURE 14



FIGURE 15

Fit the mounting bolts to the foundation plate and secure in place with nuts and washer.

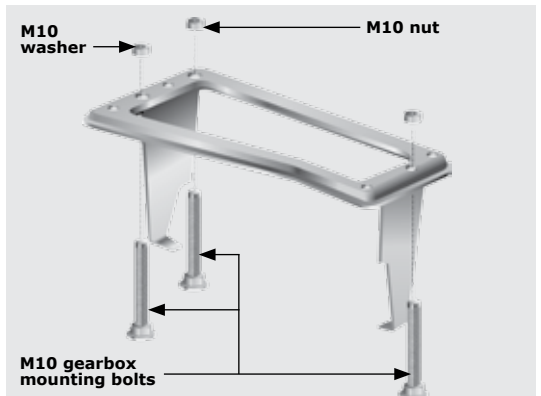

FIGURE 16



ENSURE THAT MOUNTING STUDS AND LOCKNUTS ARE FITTED BEFORE setting the foundation plate in concrete or bolting to an existing plate.

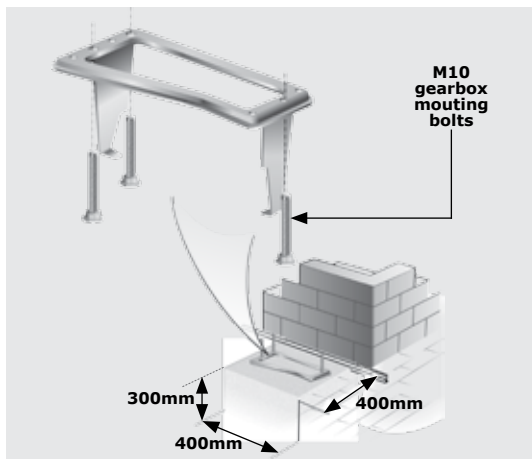

FIGURE 17

Do not finish pouring concrete before the cables have been installed – see next section Route Cable and Secure Foundation Plate on page 28.

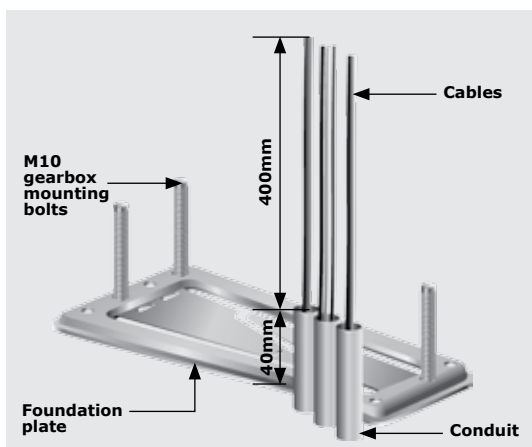

FIGURE 18

Option 2: Bolt foundation plate onto an existing concrete plinth

If bolting onto an existing concrete plinth, place the foundation plate down in the correct position and use the plate as a template for marking the rawlbolt holes.

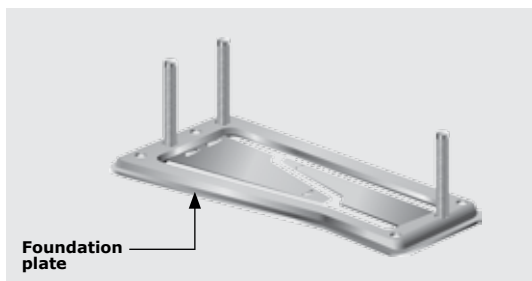

FIGURE 19

Fit the mounting studs to the foundation plate and secure in place with the stud locknuts.



Do not bend out the anchor brackets.

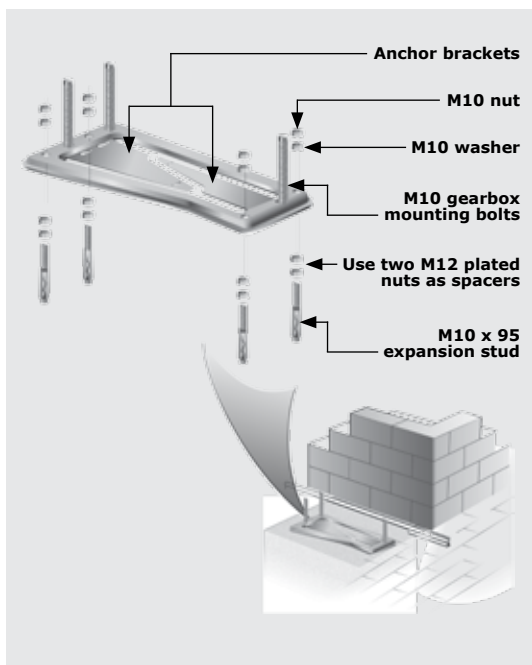

FIGURE 20

Route Cables and Secure Foundation Plate

Route cables as determined in Section 7, Cabling Requirements.

Make sure that all cables and conduits protrude at least 400mm above the foundation plate once installed.

Securely concrete or bolt the foundation plate in position.

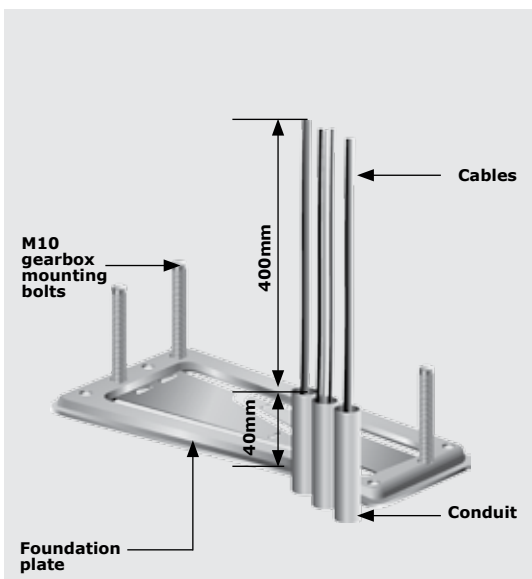

FIGURE 21

Option 3: Retrofitting D2 Turbo to an existing D3 foundation plate.

Grind off the existing mounting studs from the D3 foundation plate as shown in Figure 22.

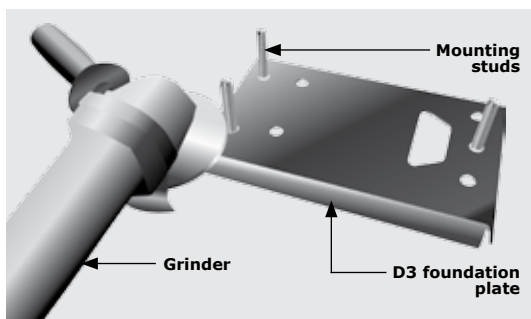

FIGURE 22

Fit the three mounting studs to the D2 Turbo foundation plate and secure in place using the stud locknuts supplied with this kit. The half-height nuts should be used on the underside of the plate as shown in Figure 23, as these will later be used for height adjustment. However, if space allows – i.e. there will be sufficient clearance between the rack and the pinion once the operator has been mounted – the orange height-adjustment nuts may be used

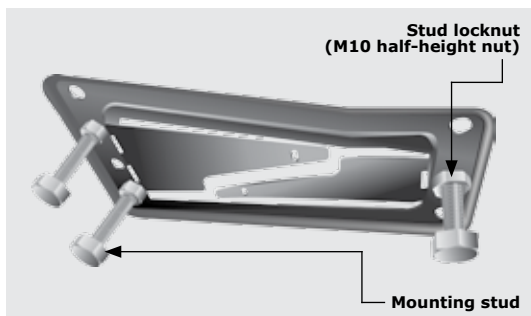

FIGURE 23

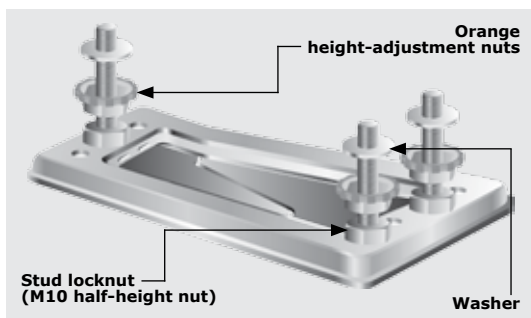

FIGURE 24



Do not attempt to mount the gearbox without using either the half-height nuts or the orange jacking nuts as doing so will result in the gearbox being damaged when the hold-down nuts are tightened.

Use the supplied full-height hold-down nuts to temporarily secure the plate in place from above as shown in Figure 24.

Place the D2 Turbo foundation plate onto the existing D3 plate in the optimum position.

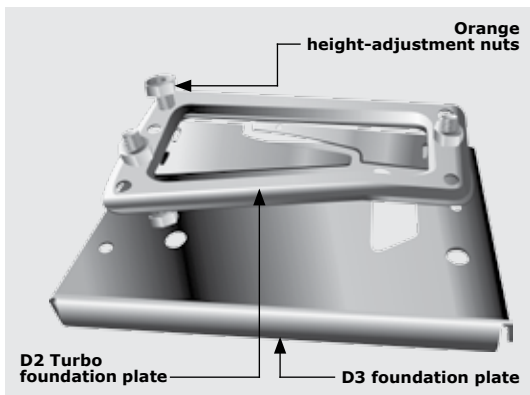

FIGURE 25

Carefully tack-weld the head of each individual mounting stud onto the D3 foundation plate.

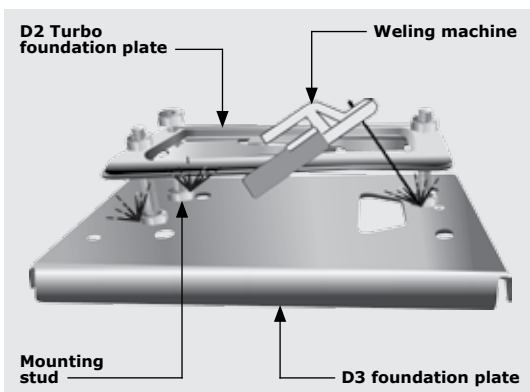

FIGURE 26

Remove the hold-down nuts and lift the D2 Turbo foundation plate off of the mounting studs.

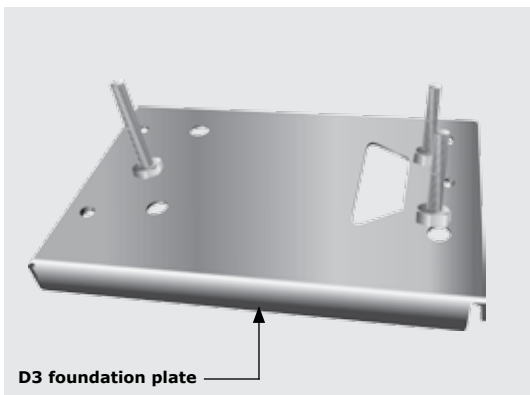

FIGURE 27

10.2. Route Cables and Secure Foundation Plate

Route cables as determined in Section 7, Cabling requirements

Make sure that all cables and conduits protrude at least 400mm above the foundation plate once installed. Cable entry is allowed for in the far left-hand side corner of the gearbox.

Securely anchor the foundation plate in concrete or bolt it in position.

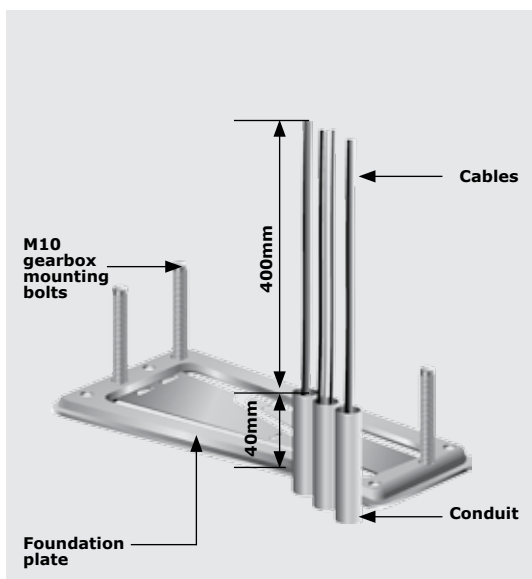

FIGURE 28

10.3. Mount the gearbox

Fit the orange height-adjustment nuts to the base as shown in Figure 29 to level the gearbox

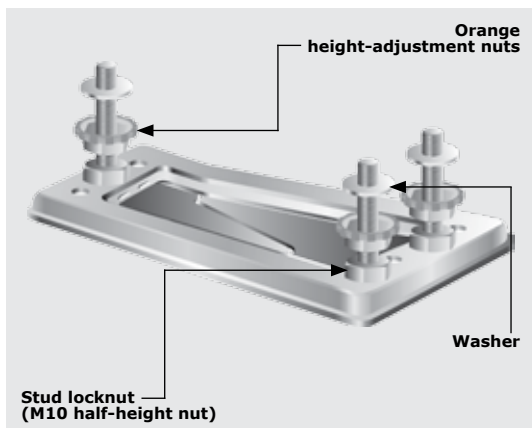

FIGURE 29

At the start of the gearbox installation, install the gearbox so that the bottom of the gearbox is 7mm above the foundation plate. This is done so that the pinion of the operator can be used as a pivot point to ensure that the rack is installed level. Once the rack is on the gate, the gearbox is lowered so that it is 5mm above the foundation plate. This is done to ensure that there is enough space for future adjustment, in the case where the rack lowers on to the pinion over time, causing added friction.

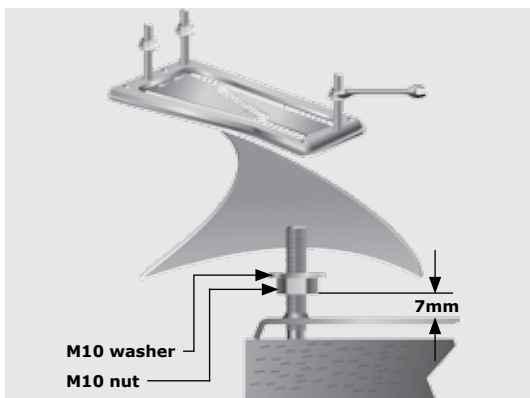

FIGURE 30

Secure the gearbox in place, fitting a washer, spring washer and M10 hold-down nut onto each gearbox mounting.

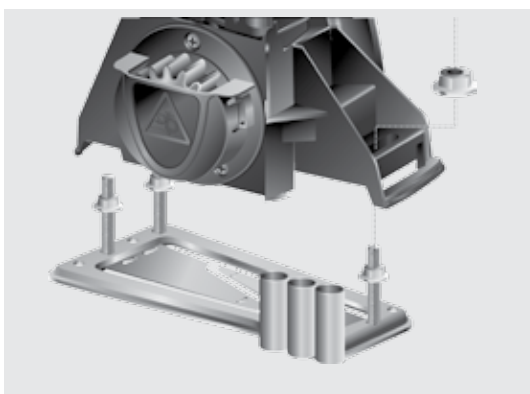

FIGURE 31

Feed the cables through the dedicated cable entry indent while fitting the gearbox to the foundation plate.

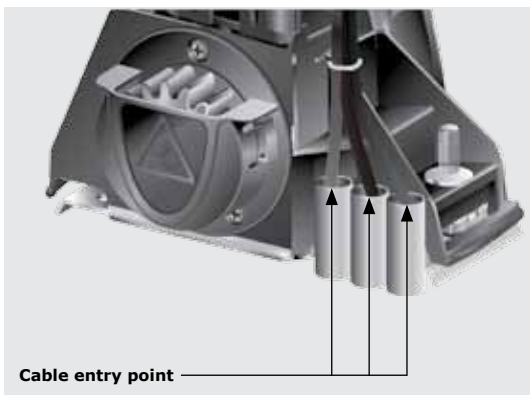

FIGURE 32

Note how the cables route up into the control card.



FIGURE 33

Tighten the hold-down nuts when the gearbox is in the correct position.

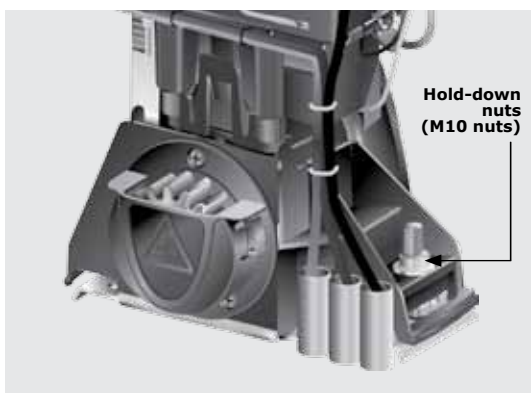

FIGURE 34



Theft-resistant Nut and Discus padlock are available for sites requiring additional security.

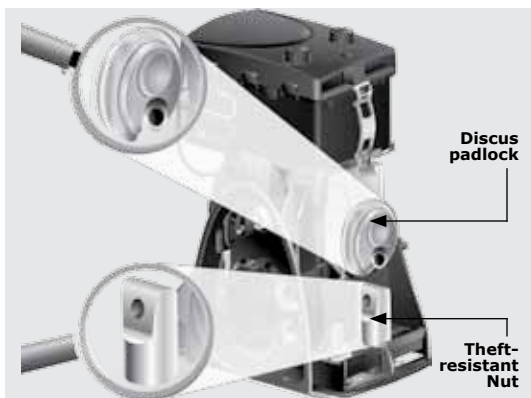

FIGURE 35

10.4. Mount the rack



The rack must be securely mounted to the side of the gate, it must be parallel with the gate rail and there must be a 2mm - 3mm gap between the teeth of the pinion and the rack along the entire travel of the gate. Follow this procedure whether mounting steel, RAZ or nylon angle rack. Refer to the sections that follow for specifics about the mounting of each type of rack

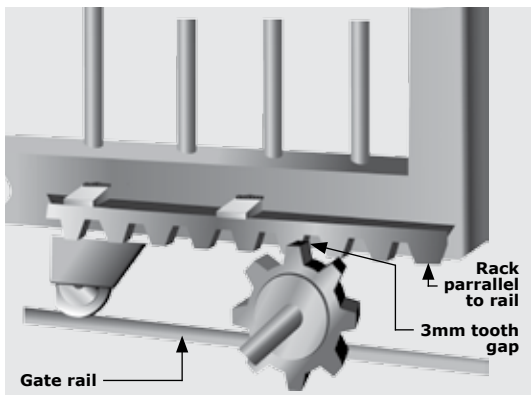

FIGURE 36

Before mounting the rack, raise the operator an additional 3mm.

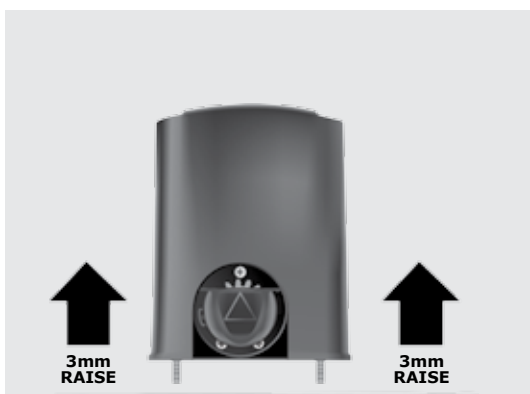

FIGURE 37

Put the gearbox into Manual Mode. Refer to Section 18.



FIGURE 38

Start with the gate either fully open or fully closed.

Place the one end of the first section of rack on the pinion. Let it mesh fully.

Level the other end and fix that end to the side of the gate.



Refer to sections that follow for instructions on how to fix the different types of rack.

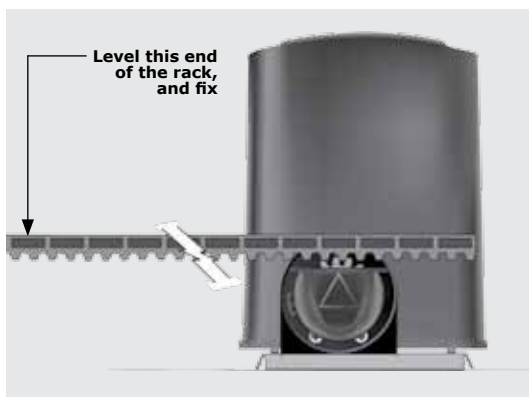

FIGURE 39

Slide the gate halfway along the first section.

Level the unsecured end, ensuring that the rack is resting on the pinion, not pressing down on it.

Before fully fixing each section of rack, slide the gate backwards and forwards along the section, checking that the rack is only resting on the pinion, not pressing down on it.

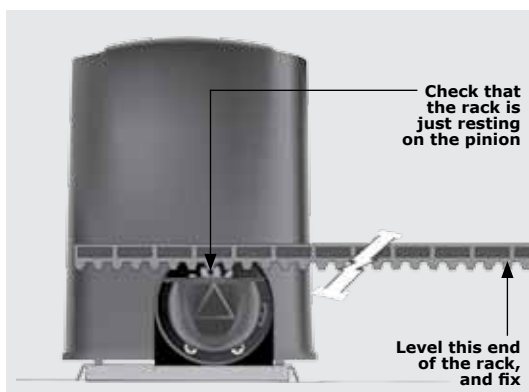

FIGURE 40

Continue this way to fix all sections.

Finally lower the operator 3mm to achieve the required 3mm tooth clearance.

Ensure that operator mounting bolts are securely tightened

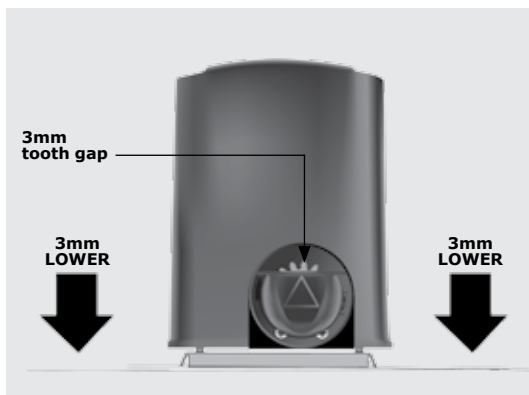

FIGURE 41

10.4.1. Steel rack

Fit the rack using the steel angle brackets provided.

Brackets must be spaced no more than 300mm apart.

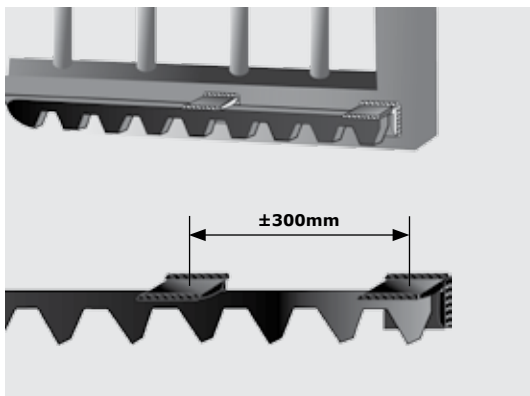

FIGURE 42

When joining the different lengths of steel rack, a simple way of ensuring correct pitch spacing, is to clamp a small off-cut between the two pieces.

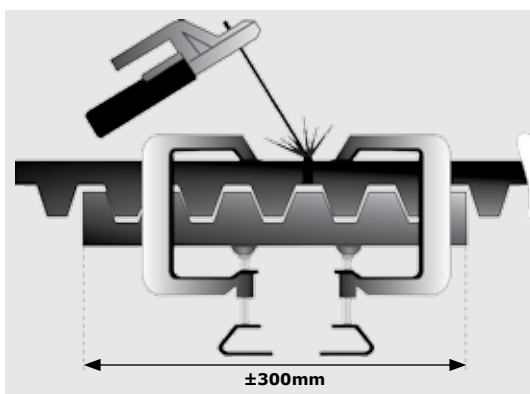

FIGURE 43

10.4.2. RAZ rack

Fix the RAZ rack to the side of the gate using the TEK Screws provided. Use the vertical slots in order to allow for adjustment.

Use at least three TEK screws per half metre section of rack.

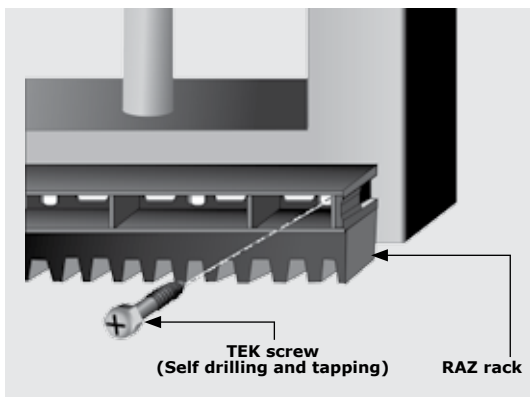

FIGURE 44

When fitting RAZ rack it is easier to start on the right and work towards the left.

RAZ rack simply clips together.

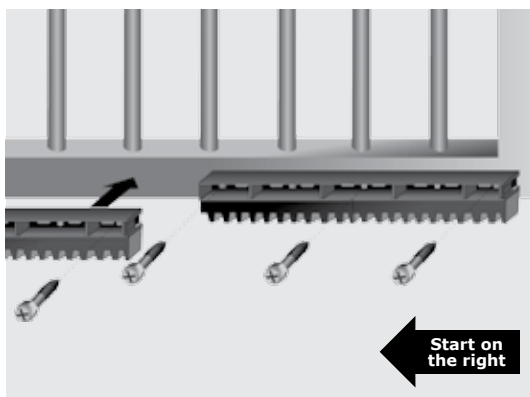

FIGURE 45



Fit additional fixing screws through the horizontal slots to secure the rack to the gate directly above the pinion when the gate is in the closed, pedestrian and open positions.

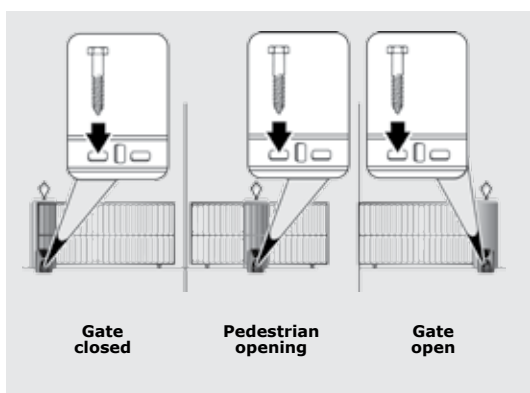

FIGURE 46

10.4.3. Nylon Angle rack

Fix the rack to the side of the gate using the TEK screws provided.

Ensure that all the mounting holes provided in the angle section are used

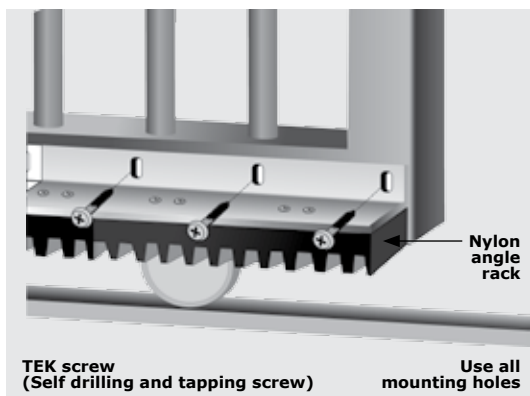

FIGURE 47

When joining two lengths together, simply butt each section firmly together to ensure the correct pitch.

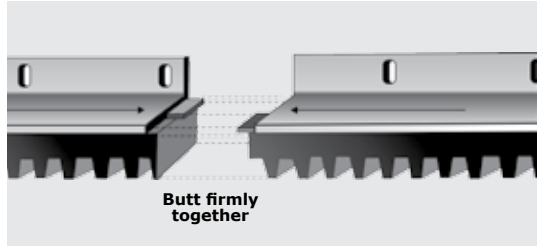

FIGURE 48

10.5. Mount the origin marker

Close the gate completely.

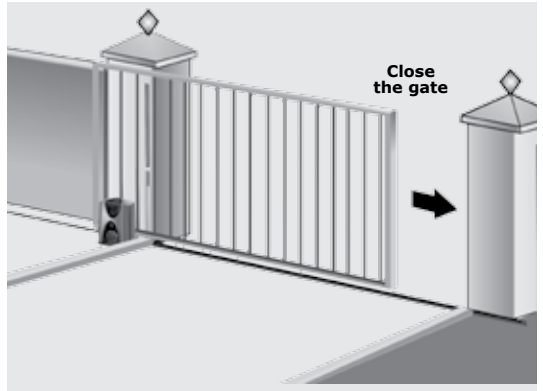

FIGURE 49

Mount the origin marker to the rack, making sure that there is a minimum of 500mm from the origin sensor. Refer to Figure 50, isometric view A or plan view B.



It is possible to make the distance between the origin marker and the origin sensor much greater than 500mm. However, if using the Pedestrian Opening facility, it is preferable to mount the origin marker inside of the Pedestrian Opening point (even though the position of the marker will not affect the width of the Pedestrian Opening).

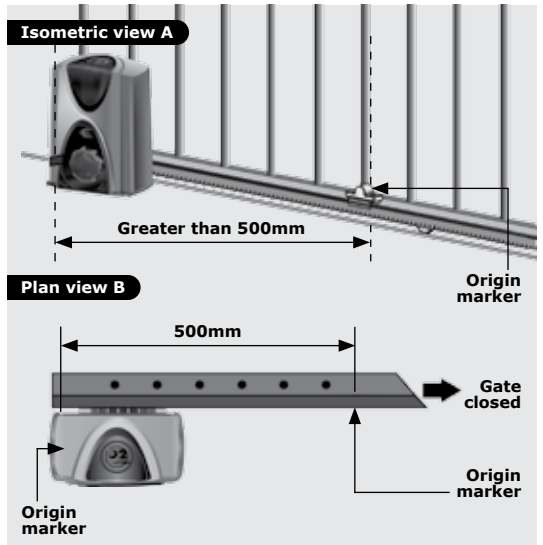

FIGURE 50

For the steel rack, mount the origin marker onto the rack using the bracket provided.

Weld the bracket to the rack.

Bolt the origin marker onto the bracket using the fasteners provided.

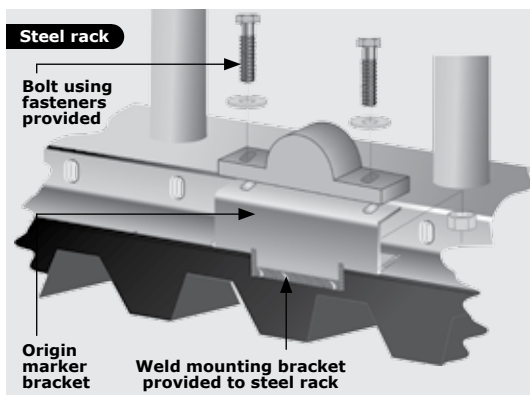

FIGURE 51

With RAZ rack the origin marker mounts directly on top of the rack without a bracket.

Drill mounting holes directly into the rack and bolt into position.

File away the front lip of the rack if you need to move the origin marker closer to the operator as the gate slides past.

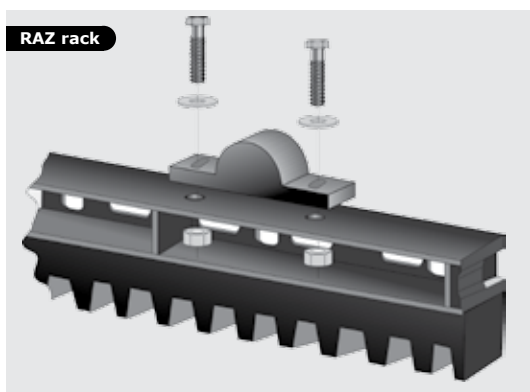

FIGURE 52

With Nylon Angle rack it is necessary to use the bracket provided.

It is preferable to use self-tapping fasteners to secure the bracket into the side of the nylon rack as shown.

Make a small tack weld to secure the back of the bracket onto the angle iron section of the rack.

Bolt the origin marker onto the bracket using the fasteners provided

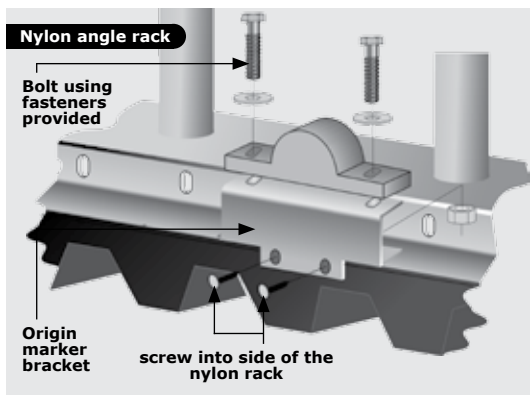

FIGURE 53

Note the orientation of the origin marker.

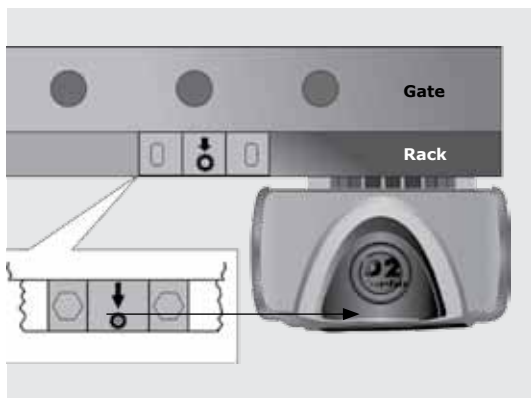

FIGURE 54

Manually slide the gate open until the origin marker is in line with the origin sensor.

Ensure distance between the face of marker and front face of the sensor is between 13mm and 20mm.

Adjust distance by sliding the origin marker along the slotted mounting holes until the specified distance is achieved.

With Nylon Angle rack it is necessary to use the bracket provided.

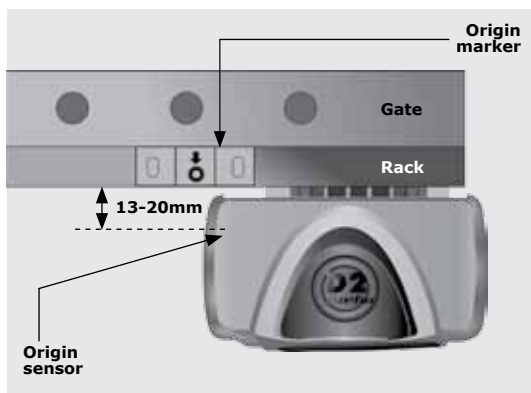

FIGURE 55



For best results keep gap between marker and sensor as small as possible.

10.6. Apply warning decal

Apply the supplied warning decals to both sides of the gate as indicated in the second drawing on the reverse side of the decal.



FIGURE 56

11. Electrical Setup

1. Always check that the circuit breaker in the electrical panel is in the OFF position, and that all high-voltage circuits (more than 42.4V) are completely isolated from the mains supply before doing any work.
2. Ensure that all low-voltage systems (less than 42.4V) are suitably protected from damage, by disconnecting all sources of power such as chargers and batteries before doing any work.
3. All electrical work must be carried out according to the requirements of all applicable local electrical codes. (It is recommended that a licensed electrical contractor perform such work)

11.1. Connect all Wiring

Connect all cables as required to the control card, according to the wiring diagrams from page 43.

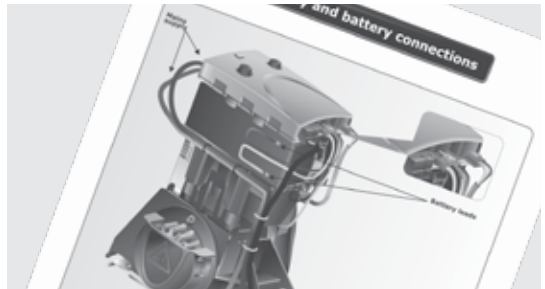

FIGURE 57

Check that the battery is connected to the controller. Refer to page 49.



Ensure that the battery polarity is correct.



FIGURE 58

Ensure that the controller is effectively earthed for improved lightning protection as shown on page 50.



FIGURE 59

11.2 Wiring Diagram for Closing Safety Beams/ Photocells

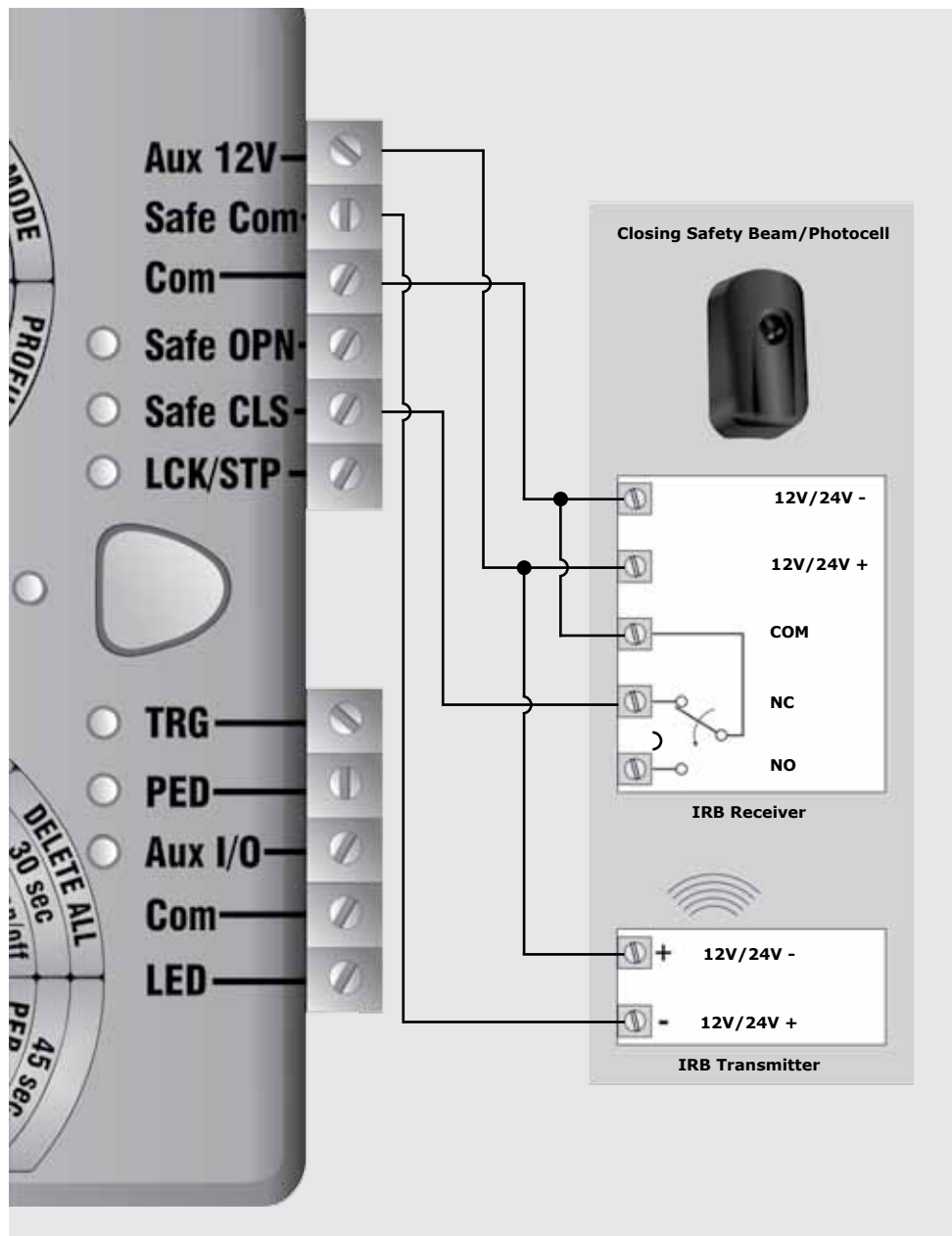

FIGURE 60

11.3 Wiring Diagram for Opening Safety Beams/ Photocells

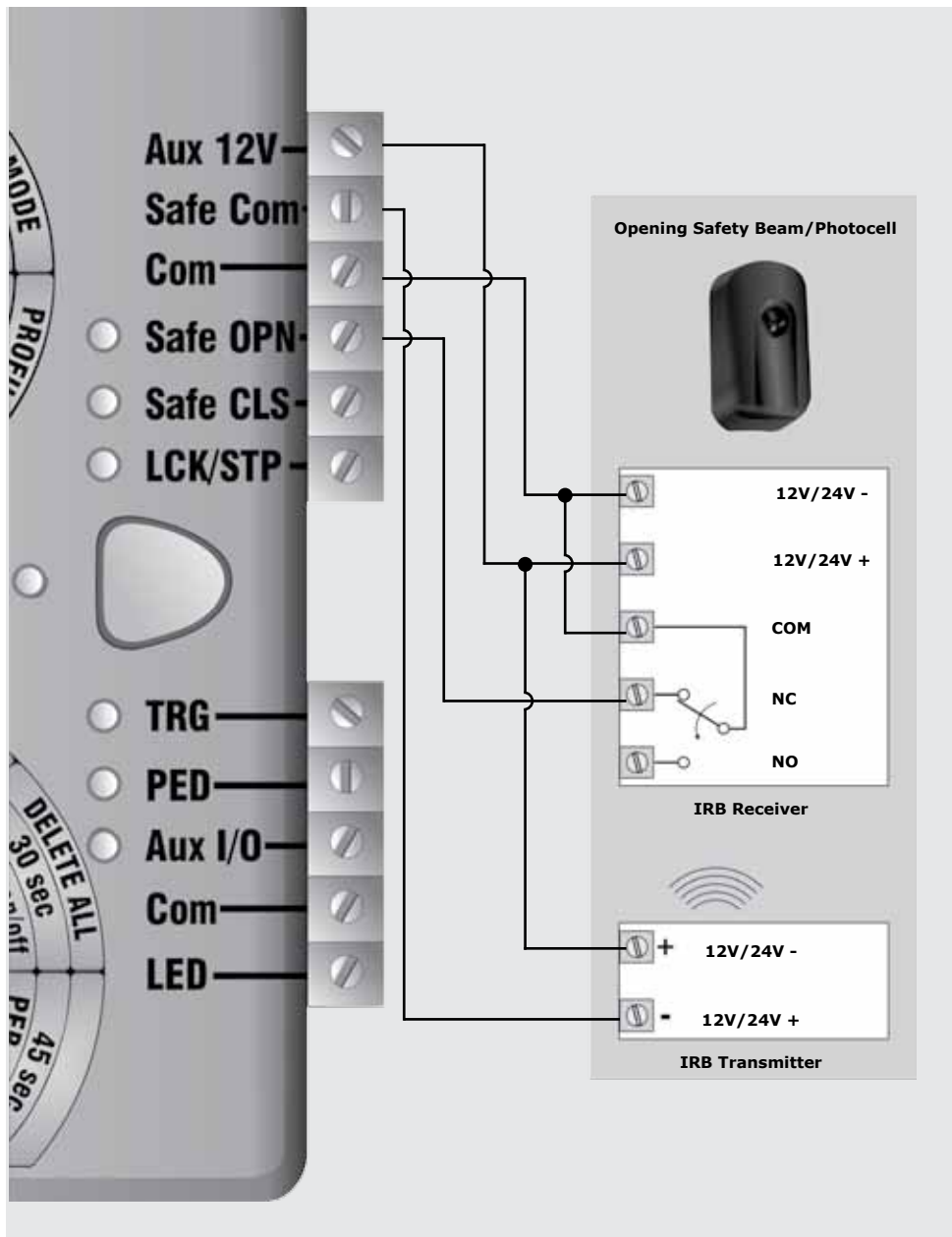

FIGURE 61

11.4 Wiring Diagram for External Radio Receiver

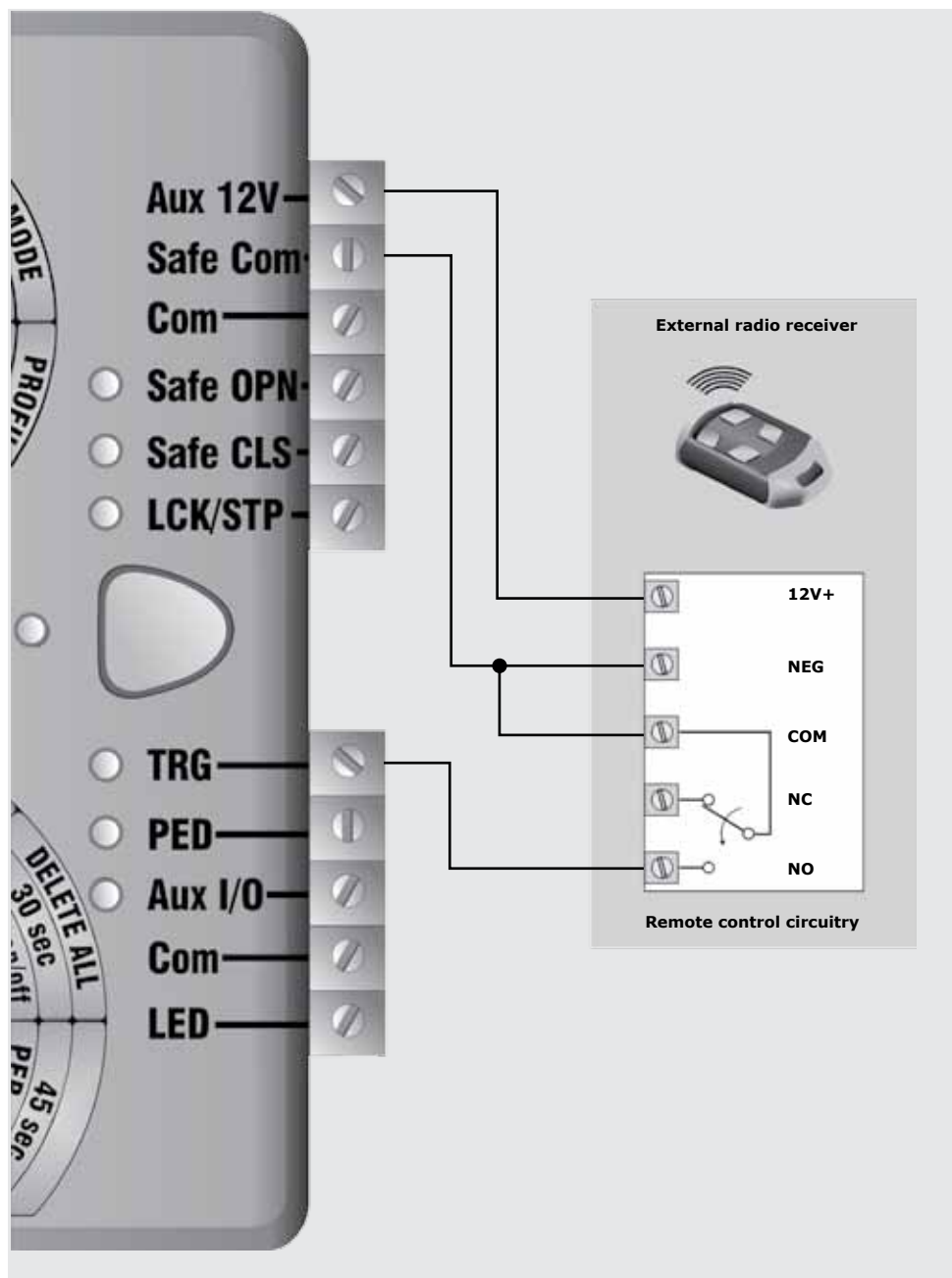

FIGURE 62

11.5 Wiring Diagram for Other Inputs

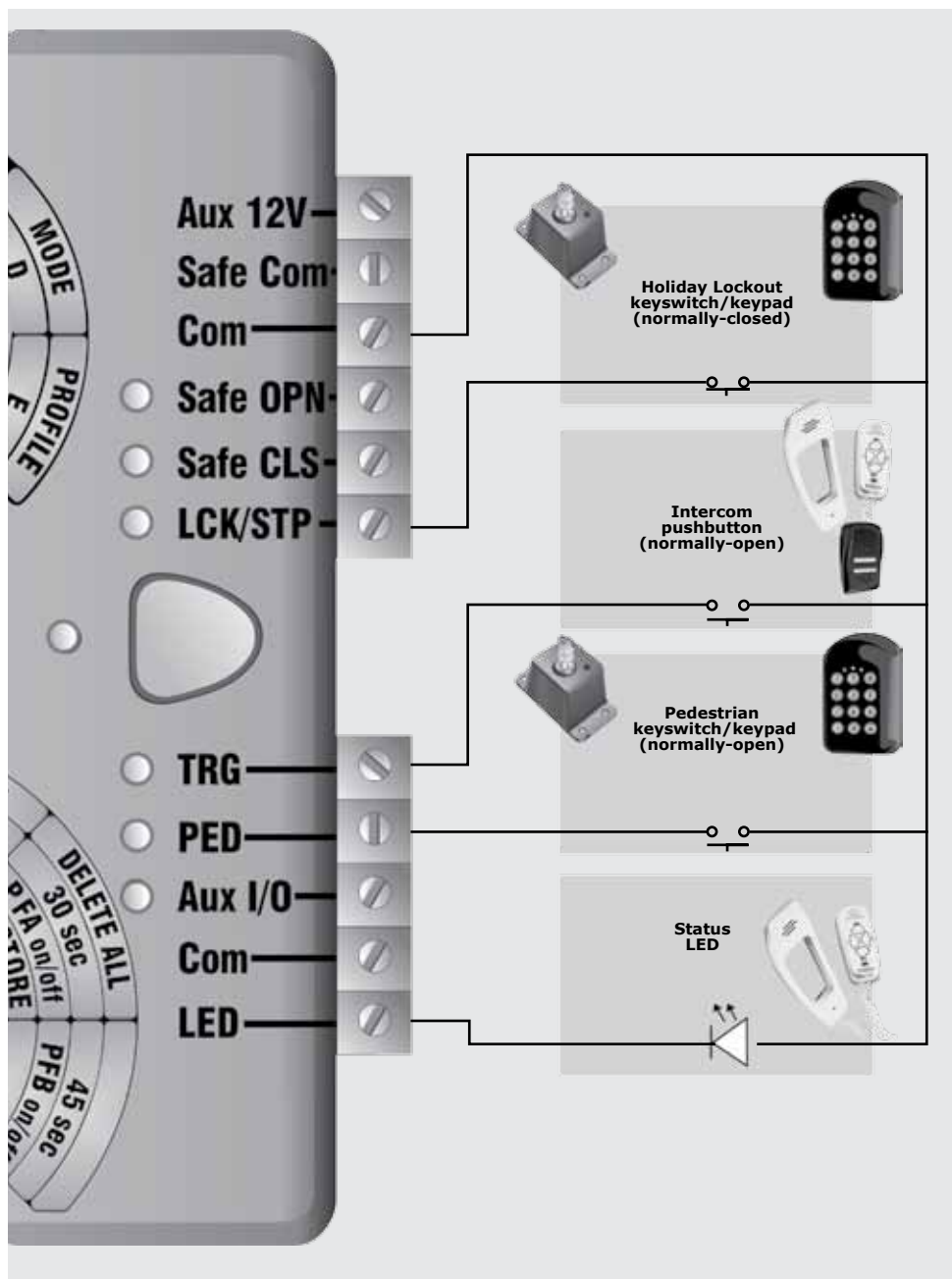

FIGURE 63

11.6 Wiring Diagram for Pillar Light to D2 Turbo

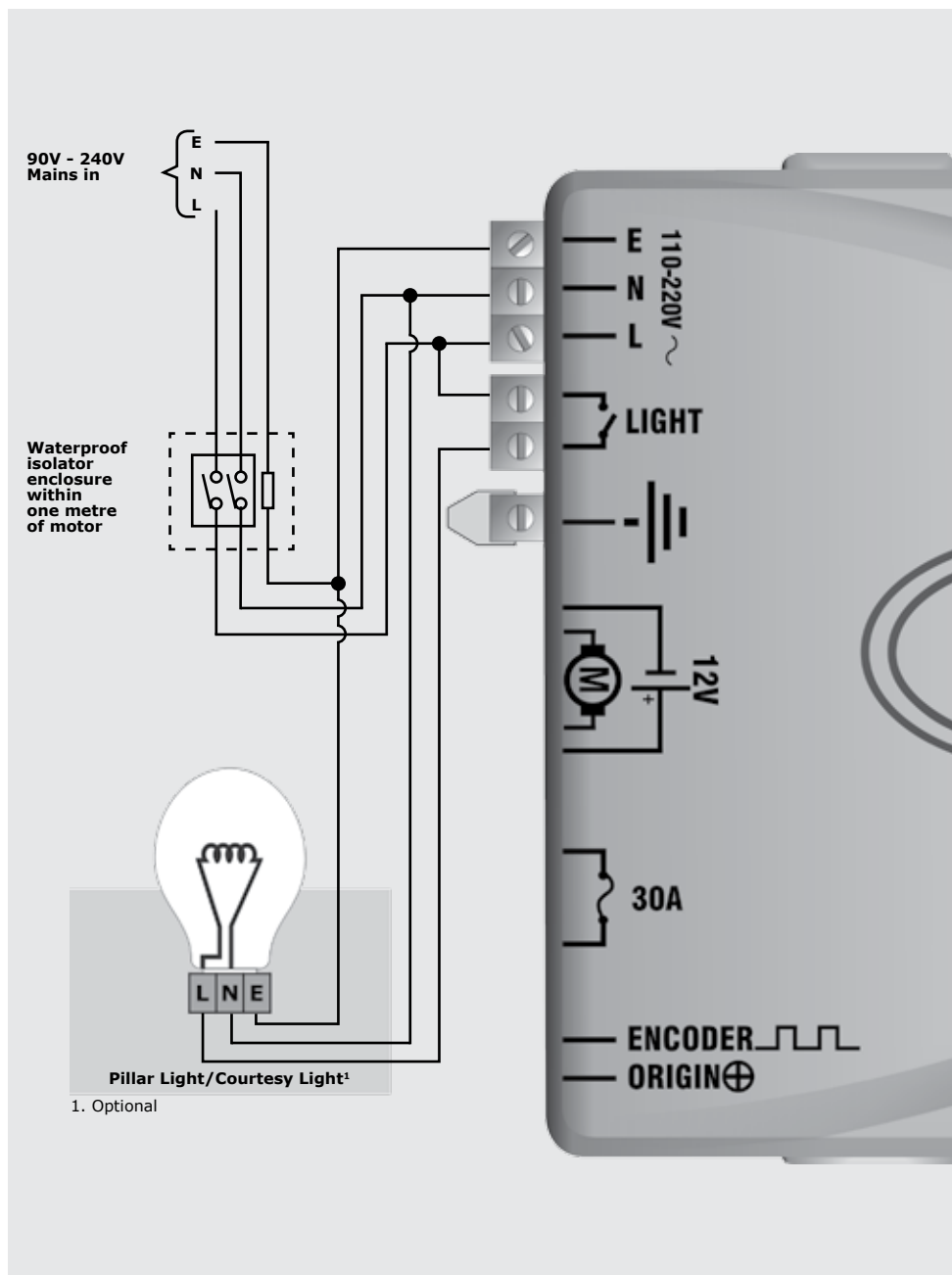

FIGURE 64

11.7 Wiring Diagram for Pillar Light to D2 Turbo Low-Voltage

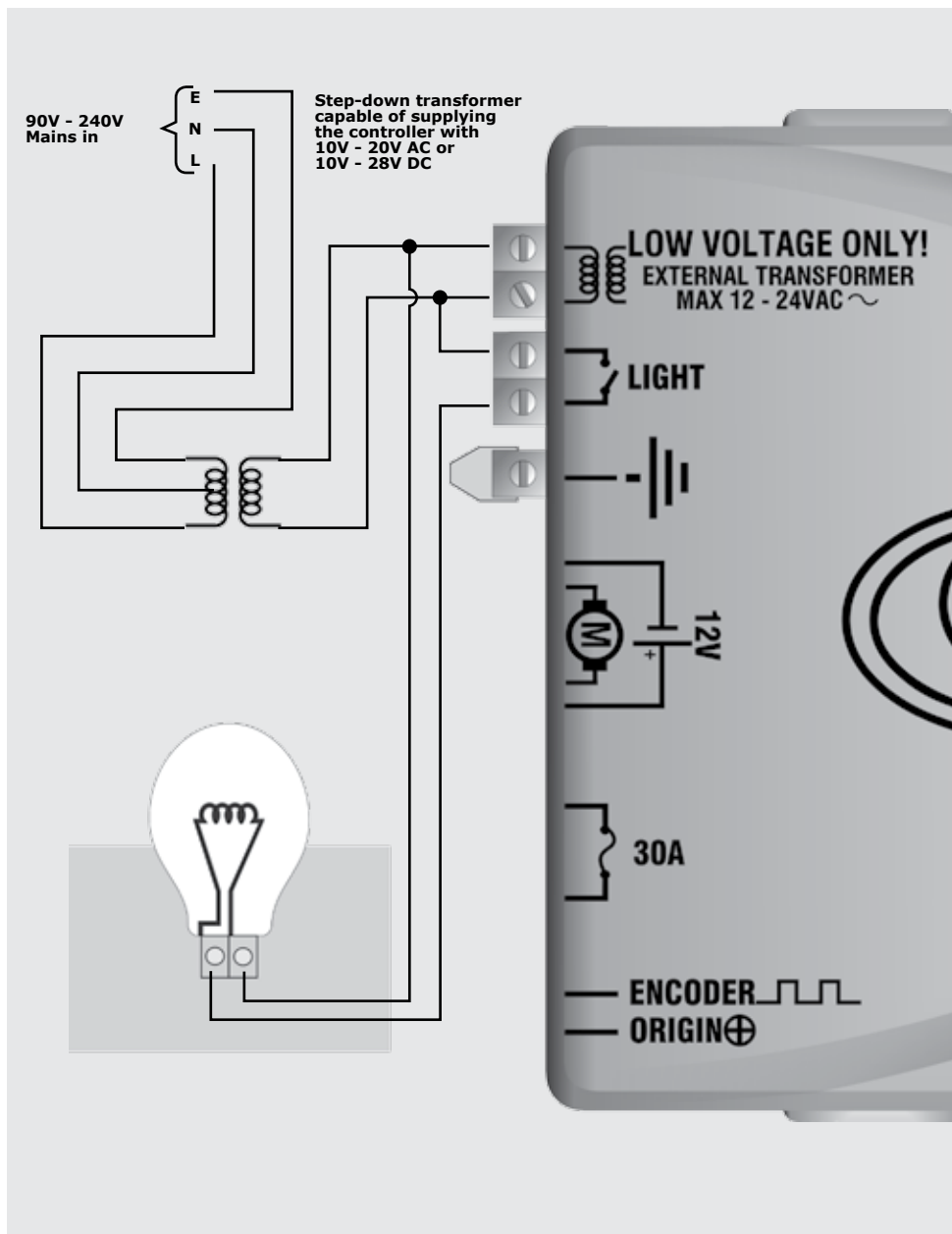

FIGURE 65

11.8 Wiring Diagram for Solar Panel to D2 Turbo

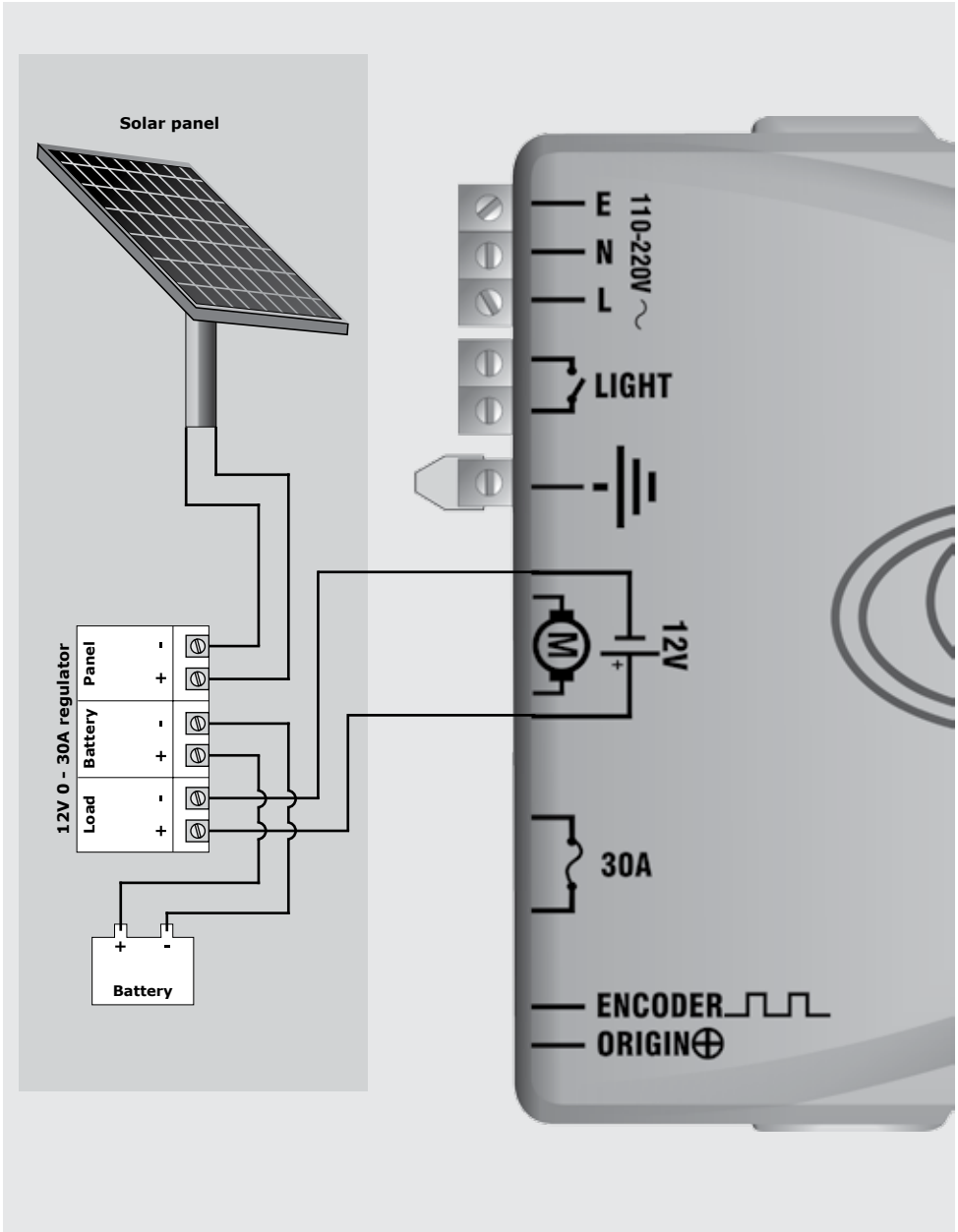

FIGURE 66

11.9 Wiring Diagram for Solar Panel to D2 Turbo Low-Voltage

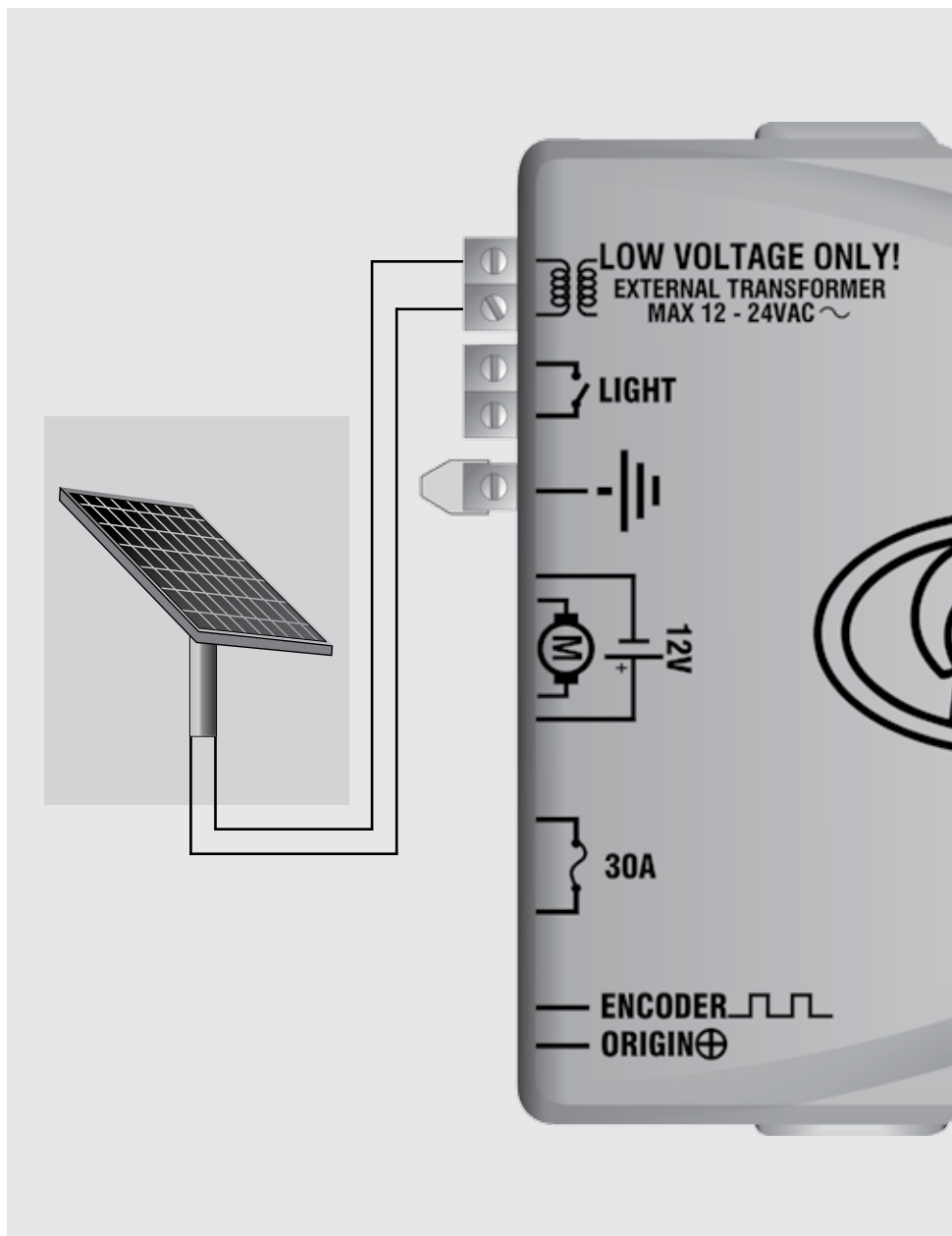

FIGURE 67

11.10 Mains Supply and Battery Connections

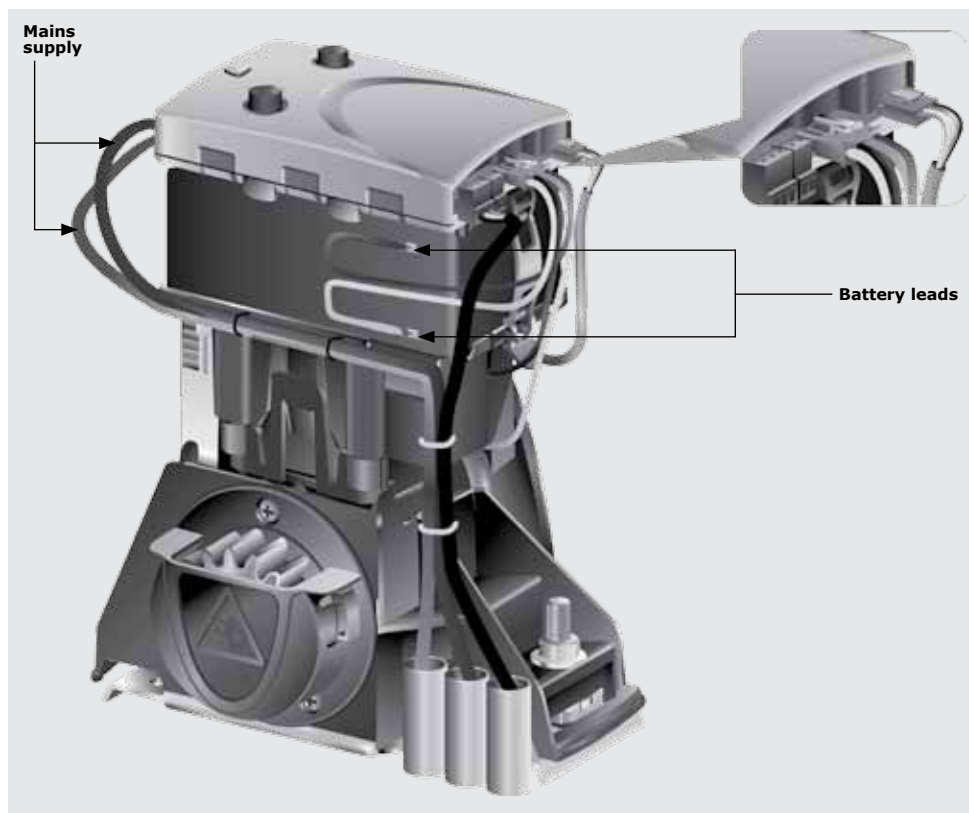

FIGURE 68

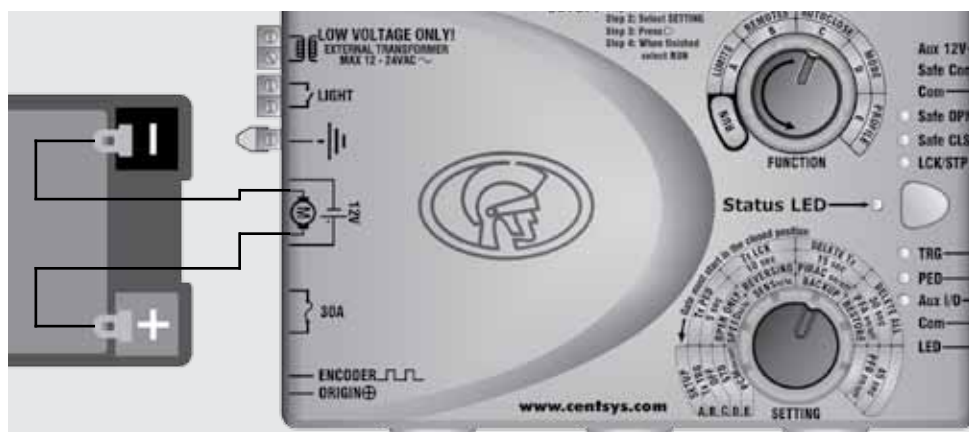

FIGURE 69

11.11 Earthing for Effective Lightning Protection

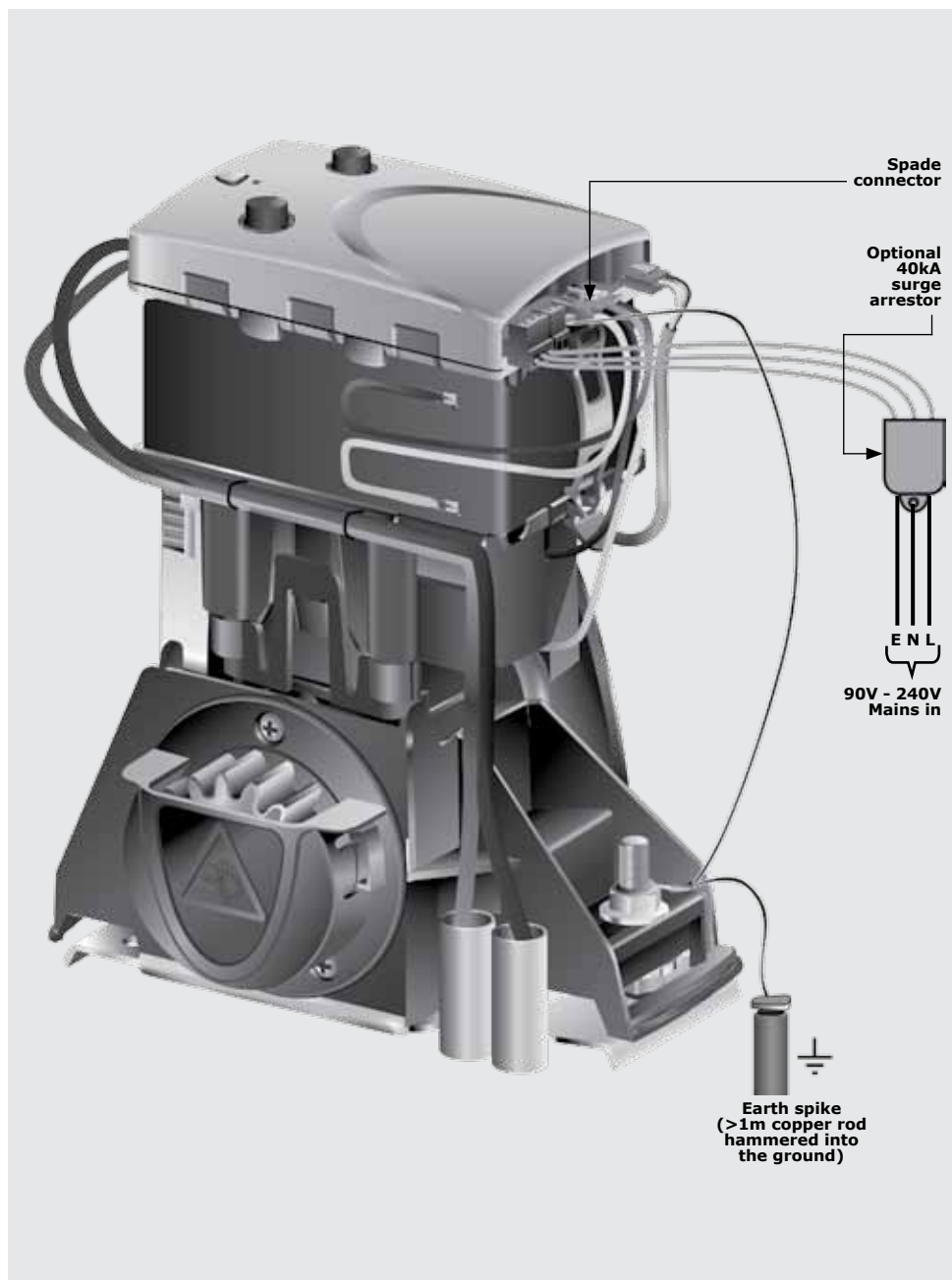

FIGURE 70

12. Commissioning the System

Introduction

The D2 Turbo and D2 Turbo Low-Voltage sliding gate operators' advanced functions are controlled by intelligent microcontroller-based electronic controllers. These systems' features and functions are enabled and disabled using the two user-friendly setting dials, with the top dial used for selecting the desired function, and the bottom dial used for selecting the specific setting to be enabled or disabled.

Setting up the gate Limits

Ensure that the gate is in the fully closed position and the motor drive is engaged.

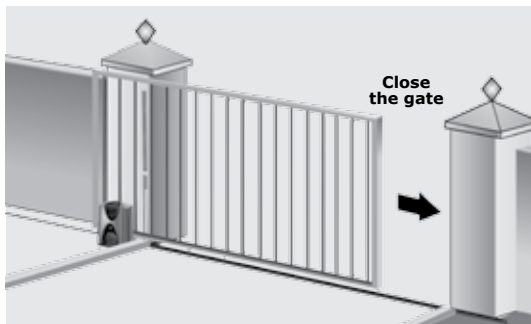

FIGURE 71

Rotate the Function Dial to the LIMITS position along the 'A' row of options.

Rotate the Setting Dial to the SETUP position along the 'A' row of options.



FIGURE 72

Press the pushbutton to select this feature.



FIGURE 73

13. Features and Functions

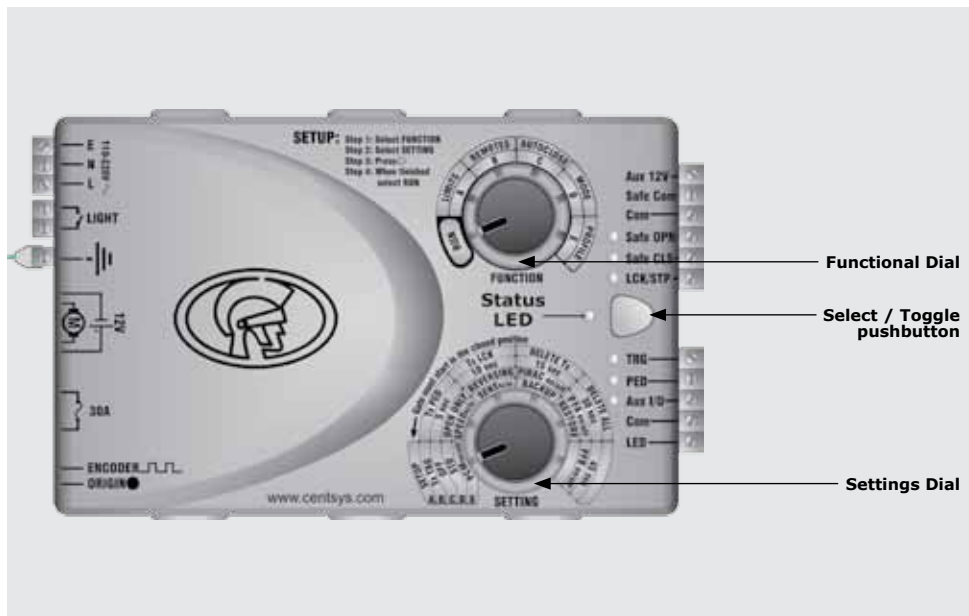

FIGURE 76. D2 TURBO CONTROLLER (ORANGE)

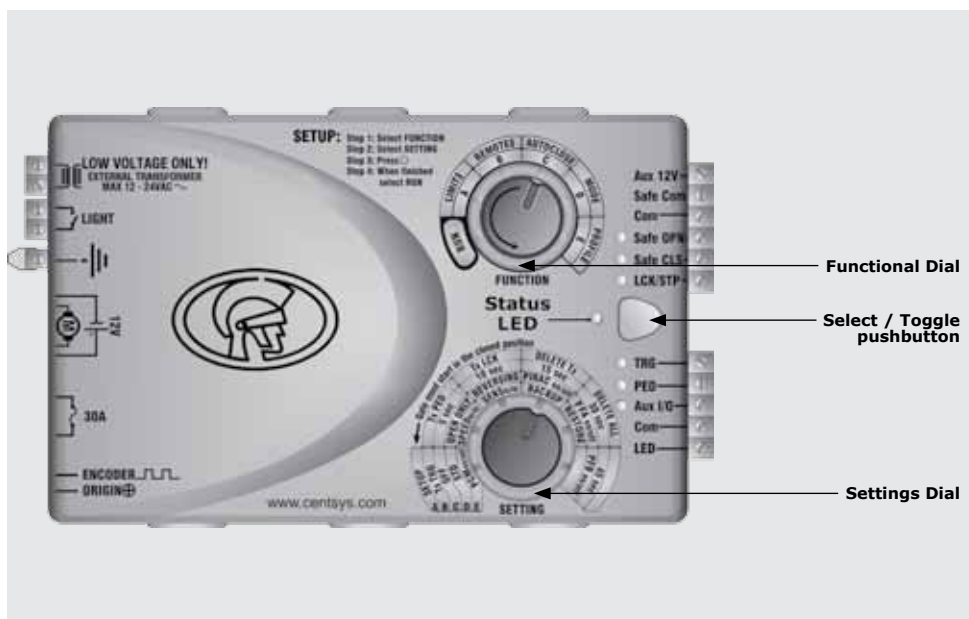

FIGURE 77. D2 TURBO LOW-VOLTAGE CONTROLLER (DARK GREEN)

Gate operation

Full Gate Opening

The remote controls supplied with the D2 Turbo are used to operate the gate.

However, most automatic gate installations are also fitted with an intercom which provides for communication between the house or building and the gate.

The handset is usually fitted with a gate pushbutton which, when pressed, sends a signal to the D2 Turbo controller to operate the gate.



FIGURE 78

Modes of Operation

To operate the gate to open fully, the D2 Turbo has three modes to choose from depending on the application. Only one mode can be selected at any given time.

Standard Mode

Standard Mode is the most commonly used mode for domestic applications as it allows full control of the gate. Press the remote control button for approximately one second to set the gate in motion. If the remote control button is pressed while the gate is moving, the gate will stop. Press the remote control button again and the gate will go into reverse.

Autoclose, explained on page 57 and PIRAC (Beam/photocell Autoclose) on page 63, can be used with Standard Mode.

Open Only Mode

This mode is ideal for increased safety in multi-user, single dwelling applications.

If you select Open Only Mode, your gate will open when you press the button of the remote control or the gate pushbutton on the intercom – but pressing the button again while the gate is opening will be ignored. It will not cause the gate to stop or to reverse. Only the internal Autoclose feature described on page 57 of this installation manual, which is automatically enabled, will close the gate if you have selected Open Only Mode.

If the button of the remote control or intercom gate release is pressed while the gate is closing, the gate will immediately reopen. The gate cannot be stopped in a midway position and will therefore always close. If the button is pressed while the gate is in the open position, the Autoclose timer (page 57) will be reset.



We highly recommend that a pair of Safety Beams are installed across the gate entrance and connected to the Closing Safety Beam input on the D2 Turbo controller if you select Open Only Mode. This will prevent the gate from closing on people, pets or vehicles (page 59).



PIRAC (Beam Autoclose) (page 63) can be used with Open Only Mode.

Reversing Mode offers slightly more security than Standard Mode as it allows you to close your gate quickly by pressing, for instance, your remote control just as you drive through the gate to prevent children or pets running out - or anybody getting in behind you. When pressing the button of the remote control or the gate pushbutton on the intercom, your gate will be set in motion. If you press the button again, the gate will move in the opposite direction. So, if the gate is opening and you press the button, the gate will stop and immediately start to close (and vice versa).



Autoclose (page 57) and PIRAC (Beam Autoclose) (page 63) can be used with Reversing Mode.

To configure any of the operating modes please refer to the section, 'Customising the Features and Functions' on page 67

Automatic closing (Autoclose Mode)

The D2 Turbo/D2 Turbo Low-Voltage has the facility to automatically close the gate after it has opened (Autoclose Mode). The time that the gate stays open is by default fifteen seconds, but this time period can be set to be five, ten, fifteen, thirty, or forty-five seconds.

As described in the previous section, Autoclose Mode is selectable with Standard Mode (page 74) and Reversing Mode (page 78) - by default the function is Off. However, Autoclose is automatically enabled in Open Only Mode.



We highly recommended that a Safety Beam is installed across the gate entrance and connected to the Closing Safety Beam input on the D2 Turbo controller, if you select Autoclose in order to prevent the gate from closing on people, pets or vehicles.

Autoclose Override

Automatic closing can be overridden in Standard and Reversing Modes by pressing and holding the button of the remote control or intercom gate release for no less than three seconds.

The gate response will be to start opening and then to stop as soon as the Autoclose Override feature is activated. On releasing the button, the gate will continue opening until fully open.

Your gate will stay open until you use the remote control or intercom gate release to close the gate. The D2 Turbo will then revert to normal Autoclose operation



The Autoclose function cannot be overridden in Only Open Mode.

To enable/disable the Autoclose function and/or change the Autoclose time, please refer to the section, 'Customising the Features and Functions' on page 67.

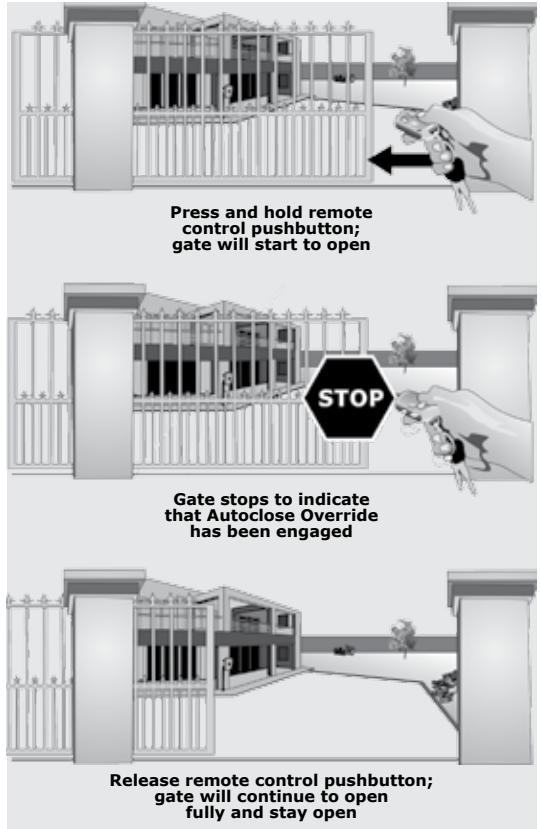

FIGURE 79

Pedestrian Opening

The Pedestrian Opening input opens the gate just wide enough for a pedestrian to pass through the opening. A second button on your remote control can be used to operate the Pedestrian Opening function. You can also connect a keyswitch or keypad mounted adjacent the gate entrance to operate this function.



FIGURE 80

There is a default two second delay before the gate opens. This is to warn the pedestrian that the gate is about to move.

It will also give the person enough time to move their hand away if they are reaching through the gate to operate a keyswitch or a keypad.

If the Courtesy Light (page 64) is connected to the D2 Turbo control card, it will flash indicating that the gate will open approximately one metre. The gate will close after a default time of five seconds.



FIGURE 81

The gate can be kept open by keeping a trigger on the input (keeping your key in the keyswitch, for example) – once removed the gate will close after the default five seconds.

If a Closing Safety Beam (page 60) is fitted and the beam is broken while the gate is closing, the gate will stop and open to the Pedestrian Opening position. The gate will remain open while the beam is broken and the five second (fixed) Autoclose Delay will only commence once the beam has been cleared.



For safety reasons, it is recommended that all Pedestrian Keyswitches and keypads are installed on the opposite end of the gate to where the operator is installed.

Safety Beam(s)/Photocell(s) (optional, but recommended)

It is always recommended to connect additional safety mechanisms to the D2 Turbo/D2 Turbo Low-Voltage instead of relying only on the inherent anti-crushing protection, referred to above. The typical device is an infrared Safety Beam/Photocell which can detect the presence of any vehicle, person or pet that breaks the beam and communicates back to the D2 Turbo that something is in the path of the gate.

Another option is an Inductive Loop Detector, which is mounted in the ground, adjacent to the gate, which is very effective at detecting vehicles or the like, but not persons or pets.

Closing Safety Beams

Closing Safety Beams provide additional protection against your gate closing on people or vehicles.

If the beam is broken while the gate is opening, the gate will continue to open.

If the gate is open, the gate cannot be closed if the beam is broken, and if the gate is closing when the beam is broken, it will stop and re-open.

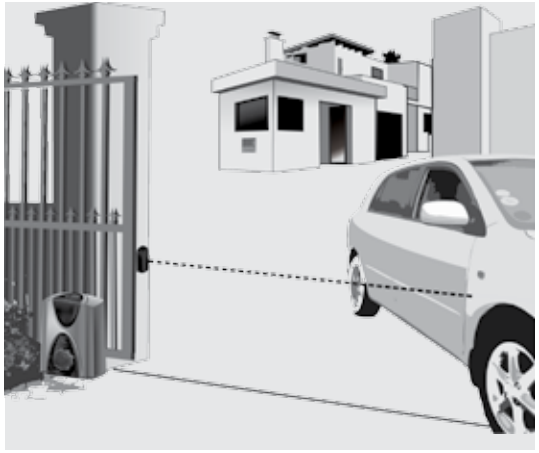

FIGURE 82

If you select the Autoclose (page 74) feature, the gate will remain open if the beam is broken and it will only close after the set Autoclose time has expired when the beam has been cleared.

Please contact us for more information on suitable protection devices.

Opening Safety Beams

These beams prevent your gate from opening if an object, person or pet is in the way.

If the beam is broken while the gate is closed, the gate will not open.

If the gate is opening and the beams are broken, it will stop then close.

If the gate is closing while the beams are broken, it will continue to close



**Gate closed - gate cannot open
 Gate opening - gate stops and re-closes
 Gate closing - gate continues closing**

FIGURE 83

Holiday Lockout Mode

This feature completely immobilises the operator and deactivates all inputs so nobody can get into your property while you are away.

One of the buttons on your remote control can be used to switch the Holiday Lockout function On and Off, as well as a latching keyswitch or keypad mounted adjacent the gate entrance, accessible from the outside of the property.

When Holiday Lockout is enabled, any and all of the access control devices that are connected to the D2 Turbo will be rendered inactive. Not even tampering with the keyswitch or keypad on the outside of the property will open the gate – this is particularly useful if you intend leaving your property unattended for extended periods of time.



FIGURE 84

If Holiday Lockout is enabled while the gate is moving or in the open position, it will only activate once the gate is back in the closed position.

If somebody tries to open the gate via a valid remote control, keypad code, etc. and Holiday Lockout is enabled, the onboard buzzer will emit one beep periodically for 30 seconds to confirm that the gate has been disabled using this feature. Only the input device that invoked Holiday Lockout will be capable of disabling it, and returning the controller to normal operation.

To enable/disable the Holiday Lockout Mode feature, please refer to the section, 'Customising the Features and Functions' on page 67.

Positive Close Mode

Positive Close Mode is intended for applications where the gate must close fully against the gate end post for security reasons – such as ensuring proper contact of a switch on the gate that feeds power to an electric fence.

This feature operates only during the last few millimetres when the gate closes.



It is recommended that a rubber strip be fixed to the front edge of the gate to reduce the noise when the gate closes against the end post.

To enable / disable the Positive Close Mode feature, please refer to the section, 'Customising the Features and Functions' on page 67.

Speed Profiles

The D2 Turbo can be set to run in either a High Speed Mode (default) which is approximately 24 metres per minute, or a Low Speed Mode which is approximately 16 metres per minute.

High speeds offer a greater level of convenience and security, while slower speeds ensure increased levels of safety at the gate.

To change the Speed Profile, please refer to the section, 'Customising the Features and Functions' on page 67.

Anti-crushing Sensitivity

The D2 Turbo incorporates a sensitive electronic anti-crushing technology that responds in the event that a person or vehicle obstructs your gate.

Using this technology, the typical response for an opening gate is to immediately stop and retract a short distance, while a closing gate will stop and fully reopen.

Collision Sensing can be set to either High Sensitivity or Low Sensitivity. Generally High Sensitivity should be used, but in instances where the gate runs very poorly, for example if the gate's rail is damaged, Low Sensitivity can be selected.

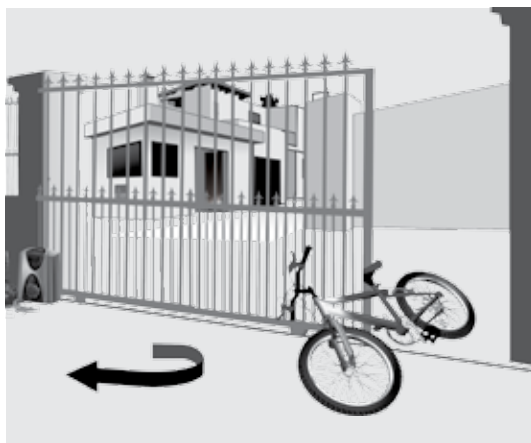

FIGURE 85

Collision Count

A counter monitors the number of collisions that the gate experiences before it fully closes. If the number exceeds the default value of four, the gate will stop. The Status LED (page 88) will flash four times every second until a remote control or intercom gate release pushbutton is pressed.

Please refer to Gate Status Indication (page 88) for more information on this diagnostic device.

PIRAC

With PIRAC Mode enabled, your gate will close as soon as you have driven through and passed the Safety Beams – giving intruders no time to follow behind you.

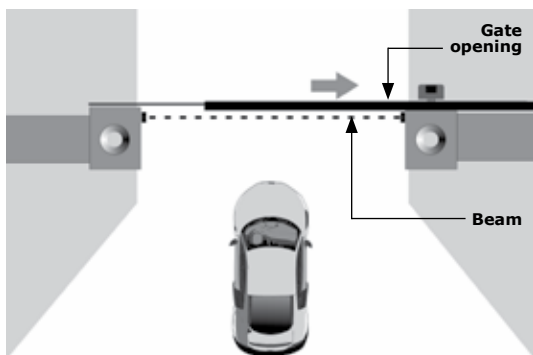

FIGURE 86

If Autoclose is enabled and the gate has been opened but nothing moves through the Closing Safety Beam, the gate will stay fully open for the duration of the Autoclose timer before closing. However, if something passes through the Closing Beam the gate will close immediately.

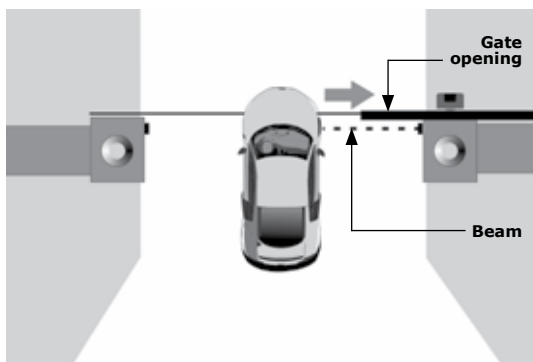

FIGURE 87

If something crosses the beam while the gate is opening, the gate will continue to open until the beam is cleared. Once the beam is cleared, the gate will stop and close. If the gate has reached its fully open position, it will stop and remain open until the beam is cleared.

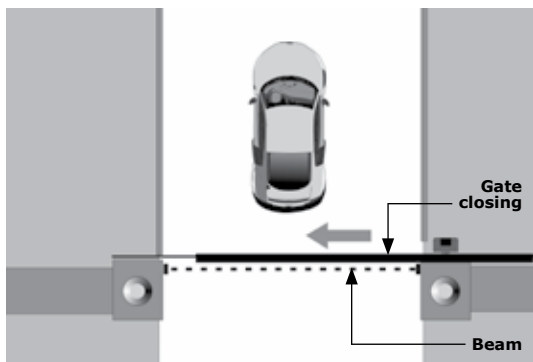

FIGURE 88

To enable/disable PIRAC Mode, please refer to the section, 'Customising the Features and Functions' on page 65.

Courtesy (Pillar) Light Timer (optional feature)

Courtesy (Pillar) Lights can be connected through the D2 Turbo/D2 Turbo Low-Voltage controller if an adequate power supply is available at the gate. The lights will switch on every time the gate is given a signal to operate (the trigger could be a remote control button, or the gate pushbutton on an intercom).

The lights will stay on for a fixed period of two minutes, then automatically turn off.

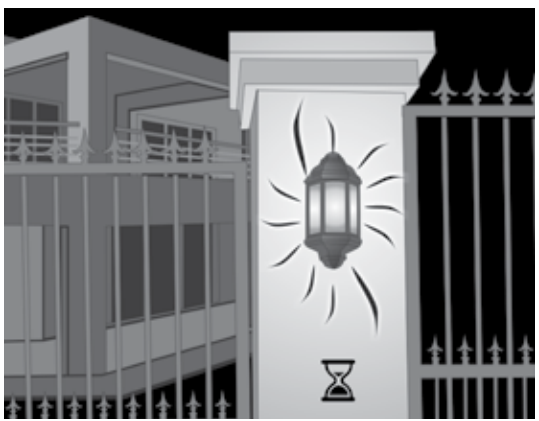

FIGURE 89

The purpose is to bathe your entrance with light when you open the gates and increase your security as you drive into your property – it also saves electricity as the lights only come on when you use the gate motor.

Using the Pedestrian Opening feature will cause the Courtesy (Pillar) Lights to flash three times before the gate opens.



The cabling that supplies the input voltage to the D2 Turbo must be suitably sized to carry the additional load of the Courtesy (Pillar) Lights.

Courtesy (Pillar) Lights act as Warning Light

These modes replace the standard Courtesy Light feature.

Pre-flashing Modes

Depending on your requirements or local regulations, your gate automation system can provide for two different safety Pre-flashing Modes which will activate the gate's Pillar Lights if fitted and connected to the D2 Turbo controller.



FIGURE 90

Pre-flashing Mode A

With Pre-flashing Mode A activated, the Pillar Light Relay will only activate during gate movement.

Pre-flashing Mode C

With Pre-flashing Mode C activated, the Pillar Light Relay will activate for two seconds before gate movement occurs, as well as during gate movement. This means that gate movement will be delayed for a period of two seconds after a trigger signal has been received.

To change the Courtesy (Pillar) to one of the Pre-flashing Modes, please refer to the section, 'Customising the Features and Functions' on page 67.

External Gate Status Indication LED

An LED (Light Emitting Diode) mounted on your intercom allows you to view the position of your gate and the condition of the battery and power supply from the safety of your home. The different signals of the LED are described below:



FIGURE 91

Off	Gate is closed
On	Gate is partially or fully open
Continuous slow flash	Gate is opening
Continuous fast flash	Gate is closing
Two flashes every two seconds	No mains present
Three flashes every two seconds	Battery voltage is low

Battery-low Protection

The controller has circuitry that monitors the state of the battery. During a power failure, energy is drawn from the battery but not replaced. To protect the battery from being quickly damaged, the protection circuitry prevents the motor from being run off the battery when the battery voltage drops below 10.6V.

Indication that the battery-low protection has been triggered is provided by the onboard buzzer and status LED on the controller (and intercom if so equipped and connected to the controller). The LED will flash three times every two seconds, and the buzzer will beep three times every two seconds.

The gate system will also shut off until such time as the battery has recharged to an acceptable level. Consult your gate automation specialist if you discover that your Battery-low Protection signal continues to re-occur.

Solar Profile

D2 Turbo and D2 Turbo Low-Voltage controllers manufactured after August 2014 support Solar Mode.

This useful profile option allows the mains fail circuitry to be bypassed in instances where solar power is being used in lieu of an electrical mains supply. The standard response of the controller upon detecting a mains failure is to emit two short beeps every two seconds but, if the Solar Profile has been selected, the condition will not be flagged.

To enable/disable Solar Mode, please refer to the section 'Customising the Features and Functions' on page 67.

14. Customising the Features and Functions

Simplicity is the ultimate sophistication'. ~ Leonardo Da Vinci

The D2 Turbo and D2 Turbo Low-Voltage controllers make ordinarily complex settings as quick and easy as possible. Using the Function and Setting Dials, the Select/Toggle pushbutton, and the bi-colour (red and green) Status LED you can set up the many features and functions in a flash.

Please always adjust the Function Dial first.

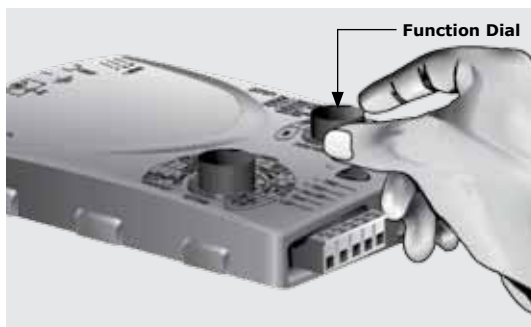

FIGURE 92

Set this to the desired function, and then move the Setting Dial to the preferred setting.

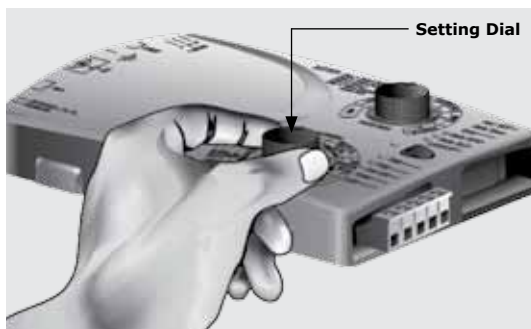

FIGURE 93

If a setting is for a single fixed value, for example, 15 second Autoclose time, then the Select pushbutton acts as a select for that single choice.

However, if the setting has two options, for example On/Off or Hi/Lo, then the pushbutton acts as a toggle between the two preferences.



FIGURE 94

When using the Select pushbutton to toggle between preferences, the status LED will light up as green to indicate On or High; or alternatively red to indicate Off or Low.



FIGURE 95



The Function Dial must always be returned to the Run position (rotated fully counter-clockwise) after you have finished setting up any of the features, modes or profiles. This ensures that it will be ready for use.



FIGURE 96

Remote control administration

The D2 Turbo controllers incorporate an onboard multichannel receiver compatible with code-hopping technology.

The receiver will allow any combination of the different inputs - Trigger (Gate fully open), Pedestrian, Holiday Lockout, etc. to be operated from a single multi-button remote control.

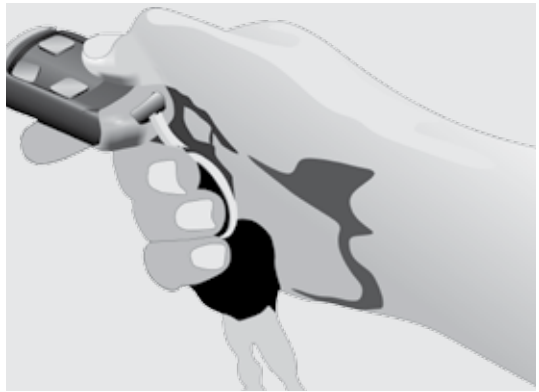

FIGURE 97

You can also artificially increase the number of buttons by using a two-button combination. One of the buttons is used as a Shift button to allow the other buttons to be used again in combination with this button. Press and hold the allocated Shift button and then press one of the other buttons to create a new button. The Shift button cannot be used as a button on its own - it must always be used in combination with another button.

Use of the Shift button principle allows a three-button transmitter to gain an extra button and operate four functions and a four-button transmitter gains two extra buttons and can operate six functions.

This is quite handy if you'd like to control additional devices from a single multi-button remote control, for example your garage doors if they are equipped with compatible code-hopping receivers.

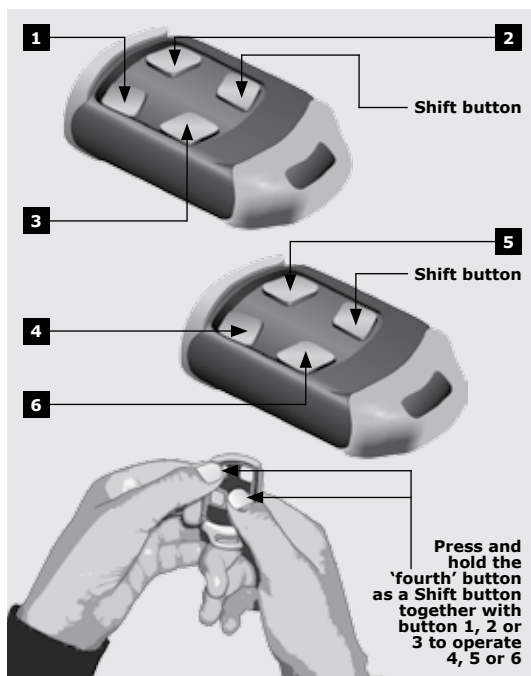

FIGURE 98

However, it's important to note that the other devices cannot be activated with the new Shift button, only the D2 Turbo (and other operators that are equipped with an onboard receiver) is able to recognise the Shift button signals.

Using the shift key principle also prevents you from enabling functions like Holiday Lockout Mode by accident. This is because you have to use both hands to press the two-button combination.

At any stage remote controls can be selectively added or deleted within the system. To selectively delete a remote control, the remote control must be available. Please refer to the section, 'Deleting Specific Remote Controls' on page 71.

Adding code-hopping remote controls

To add a code-hopping remote control to the onboard receiver and assign a button to any specific function as described above, please follow the steps below:

Step 1: Rotate the Function Dial to the REMOTES position (B).

Step 2: Rotate the Setting Dial to the desired selection along the 'B' row of options.



FIGURE 99

You can choose from the following settings:

- Tx TRG to assign a remote control button to be learned into the system and trigger the gate to fully open
- Tx PED to assign a remote control button to be learned into the system and partially open the gate for a pedestrian
- Tx LCK to assign a remote control button to be learned into the system and activate Holiday Lockout Mode



Step 3: Press the pushbutton to select the setting chosen from above – the Status LED will change from red to green to confirm the setting.



FIGURE 100

Step 4: Press the desired button on the remote control(s) that you want to activate the selected function.

The Status LED will flash twice indicating that the onboard receiver has learned in the remote control(s). The onboard buzzer will also pulse twice.

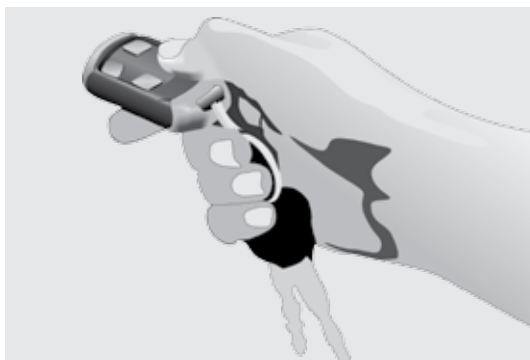

FIGURE 101

Step 5: Return the Function Dial to the RUN position.



FIGURE 102

Deleting specific remote controls

To delete specific remote controls from the D2 Turbo's onboard receiver, please follow the steps below:

Step 1: Rotate the Function Dial to the REMOTES position (B).

Step 2: Rotate the Setting Dial to DELETE Tx along the 'B' row of options. This will delete specific remote controls from the onboard receiver's memory.

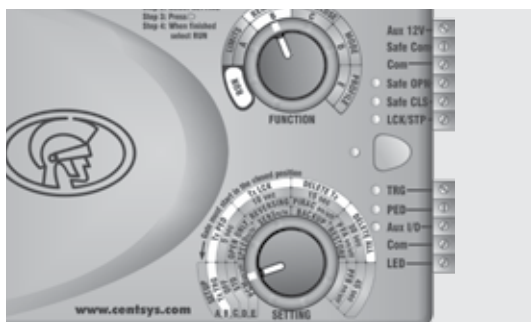

FIGURE 103

Step 3: Press the pushbutton to select – the Status LED will change from red to green.



FIGURE 104

Step 4: Press any button on the specific remote control(s) that you want to delete from the onboard receiver's memory. The Status LED will flash green three times and the buzzer will also beep three times indicating that the onboard receiver has deleted the remote control(s) from its memory.

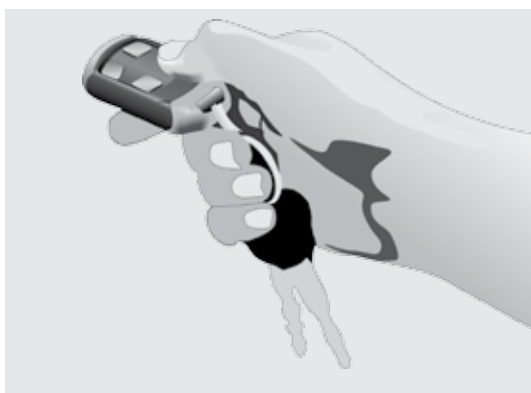

FIGURE 105

Step 5: Return the Function Dial to the RUN position.

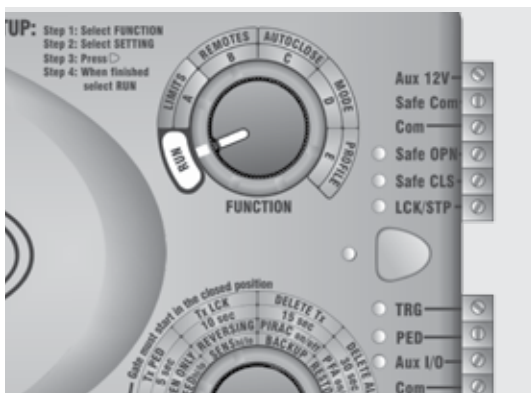

FIGURE 106

Deleting all remote controls

To delete all the learned-in remote controls from the D2 Turbo onboard receiver, please follow the steps below:

Step 1: Rotate the Function Dial to the REMOTES position (B).

Step 2: Rotate the Setting Dial to DELETE ALL along the 'B' row of options. This will delete all remote controls from the onboard receiver's memory.



FIGURE 107

Step 3: Press the pushbutton to select the setting.

The Status LED will initially flash red. Hold down the pushbutton until the Status LED turns green and three beeps are heard.

This will indicate that the onboard receiver has deleted the remote control(s) from its memory.



FIGURE 108

Step 4: Return the Function Dial to the RUN position.

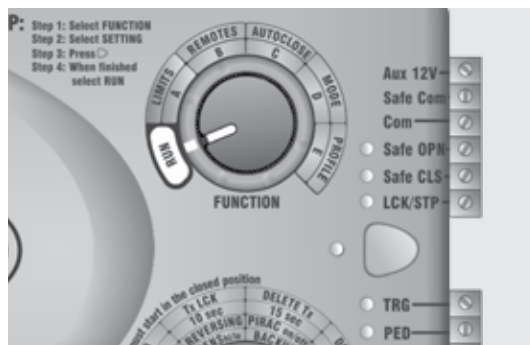

FIGURE 109

Setting the Autoclose feature

The Autoclose feature can be selected to be either Off or Activated, with a pre-selected time delay.

Activating the Autoclose feature

To activate the Autoclose, with a pre-selected time delay, please follow the steps below:

Step 1: Rotate the Function Dial to the AUTOCLOSE position (C).

Step 2: Rotate the Setting Dial to the desired time delay setting along the 'C' row of options. You can choose either 5 seconds, 10 seconds, 15 seconds, 30 seconds or 45 seconds.



FIGURE 110

Step 3: Press the pushbutton to select your choice.



FIGURE 111

The Status LED will change from red to green indicating that the Autoclose feature has been activated with the delay time selected in Step 2.



FIGURE 112

Step 4: Return the Function Dial to the RUN position.



FIGURE 113



Please note that if the operator is running Open Only Mode – the Autoclose feature is activated with a 15 second delay as the default – this can be changed if necessary.

Deactivating the Autoclose feature

To deactivate the Autoclose feature, please follow the steps below:

Step 1: Rotate the Function Dial to the AUTOCLOSE position (C).

Step 2: Rotate the Setting Dial to the OFF selection along the 'C' row of options. The Status LED will be red if Autoclose is on. If it is already Off, the Status LED will be green.



FIGURE 114

Step 3: Press the pushbutton to select.

The Status LED will change from red to green indicating that the Autoclose feature has been deactivated or switched Off.



FIGURE 115

Step 4: Return the Function Dial to the RUN position.

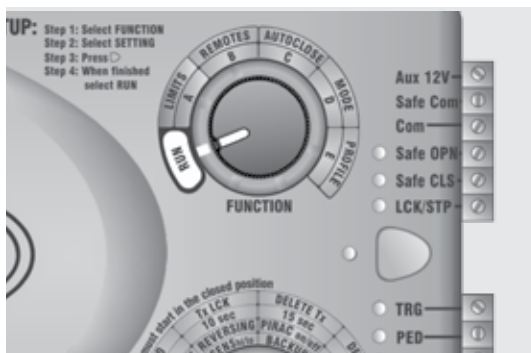

FIGURE 116

Setting the Mode of Operation

The D2 Turbo has three modes to choose from depending on the application. Only one mode can be selected at any given time

Step 1: Rotate the Function Dial to the AUTOCLOSE position (C).

Step 2: Rotate the Setting Dial to the OFF selection along the 'C' row of options. The Status LED will be red if Autoclose is on. If it is already Off, the Status LED will be green.

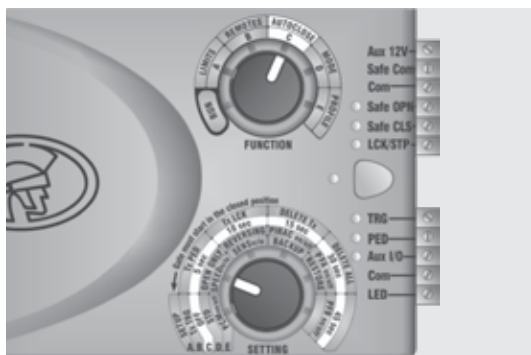

FIGURE 117

Step 3: Press the pushbutton to select.

The Status LED will change from red to green indicating that the Autoclose feature has been deactivated or switched Off.



FIGURE 118

Step 4: Return the Function Dial to the RUN position.



Please note that PIRAC Mode can be active in addition to this mode if so desired.

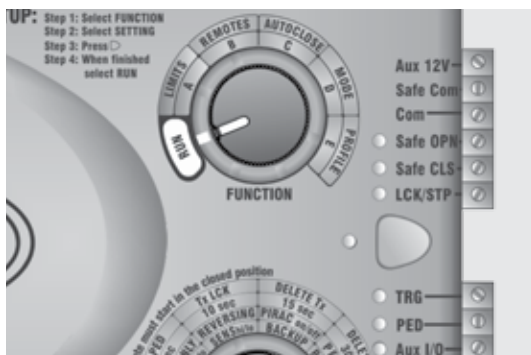

FIGURE 119

Open Only Mode

To activate Open Only Mode please follow these steps:

Step 1: Rotate the Function Dial to the MODE position (D).

Step 2: Rotate the Setting Dial to the OPEN ONLY selection along the 'D' row of options.

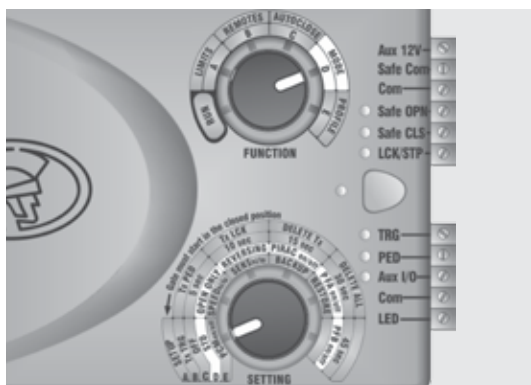

FIGURE 120

Step 3: Press the pushbutton to select the setting.

The Status LED will change from red to green indicating that the Open Only Operating Mode has been activated.



FIGURE 121

Step 4: Return the Function Dial to the RUN position.



Please note that PIRAC Mode can be active in addition to this mode if so desired.

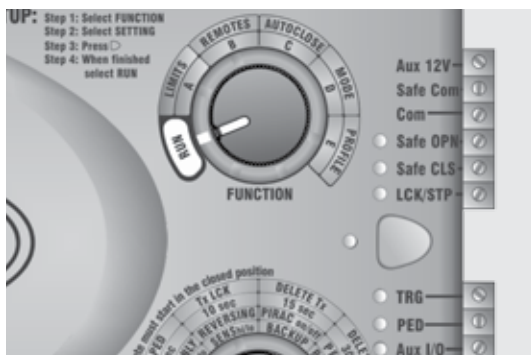

FIGURE 122

Reversing Mode

To activate Reversing Mode, please follow the steps below:

Step 1: Rotate the Function Dial to the MODE position (D).

Step 2: Rotate the Setting Dial to the REVERSING selection along the 'D' row of options.

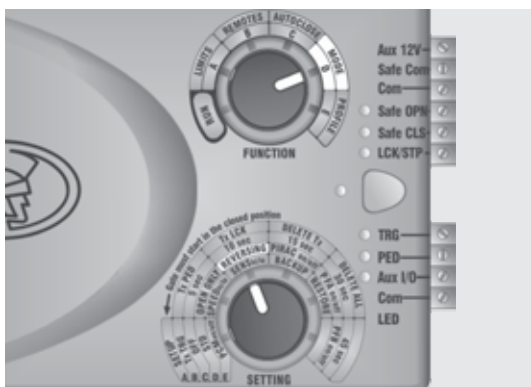

FIGURE 123

Step 3: Press the pushbutton to select the setting.

The Status LED will change from red to green indicating that the Reversing Operating Mode has been activated.



FIGURE 124

Step 4: Return the Function Dial to the RUN position.



Please note that PIRAC Mode can be active in addition to this mode if so desired.

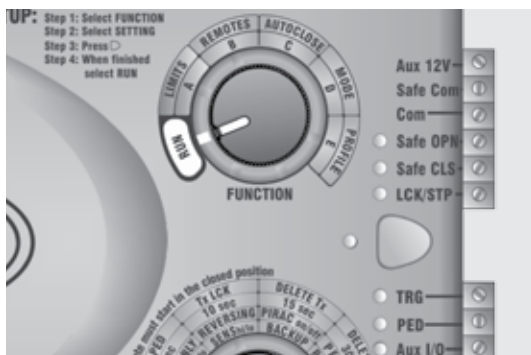

FIGURE 125

Setting PIRAC Mode

PIRAC (Beam Autoclose) Mode can be activated when using any of the three Operating Modes (Standard, Open Only, or Reversing).

To select PIRAC Mode as either On or Off, please follow the steps below:

Step 1: Rotate the Function Dial to the MODE position (D).

Step 2: Rotate the Setting Dial to the PIRAC on/off selection along the 'D' row of options.

Step 3: Press the pushbutton to select the setting.

The Status LED will change from red to green indicating that PIRAC Mode has been activated, or it will change to red indicating that PIRAC Mode has been deactivated.

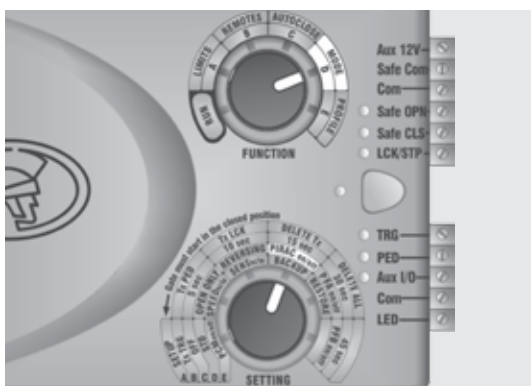

FIGURE 126



FIGURE 127

Step 4: Return the Function Dial to the RUN position.

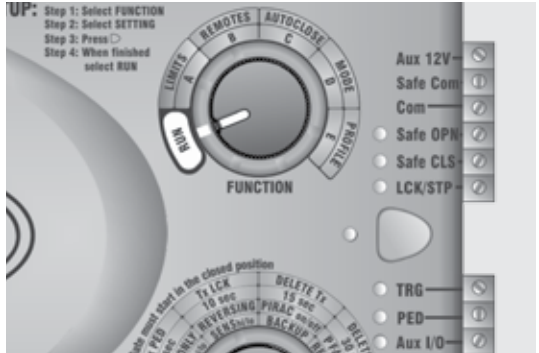

FIGURE 128

Setting the Pre-flashing Modes

Pre-flashing Mode A and Pre-flashing Mode C can be activated in addition to any of the above Modes of Operation.

To select a Pre-flashing Mode as either on or off, please follow the steps below:

Step 1: Rotate the Function Dial to the MODE position (D).

Step 2: Rotate the Setting Dial to either PFA on/off for Pre-flash Mode A, or PFC on/off for Pre-flash Mode C along the 'C' row of options.

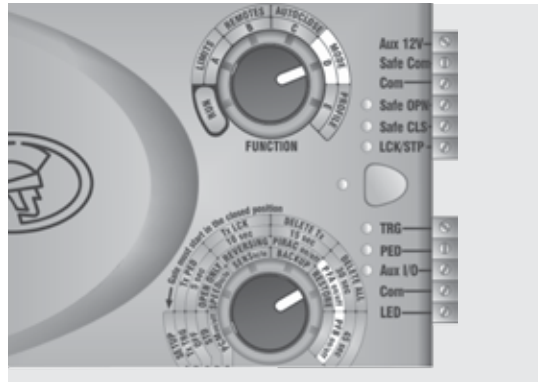

FIGURE 129

Step 3: Press the pushbutton to toggle the Pre-flash Mode between On and Off.

The Status LED will change from red to green indicating that the selected Pre-flash Mode has been activated, or it will change to red indicating that it has been deactivated.



FIGURE 130

Step 4: Return the Function Dial to the RUN position.

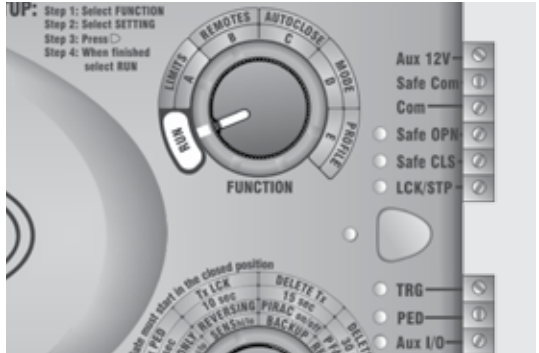

FIGURE 134

Setting the Speed Profile to High or Low

To select the desired speed profile, either High (approximately 24m/min) or Low (approximately 16m/min) please follow the steps below:

Step 1: Rotate the Function Dial to the PROFILE position (E).

Step 2: Rotate the Setting Dial to SPEED hi/lo along the 'E' row of options.

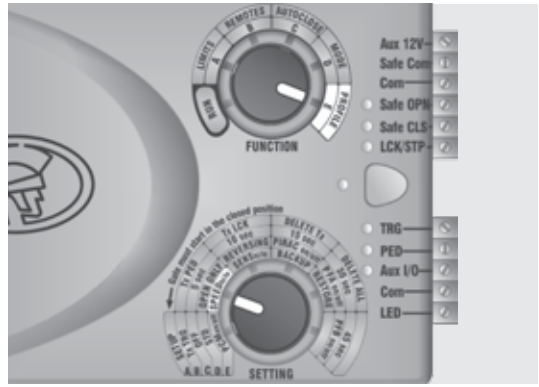

FIGURE 135

Step 3: Press the pushbutton to toggle Speed profile between High and Low.

The Status LED will change from red to green indicating that the High Speed Profile has been activated, or it will change to green indicating that the Low Speed Profile has been activated.



FIGURE 136

Step 4: Return the Function Dial to the RUN position.

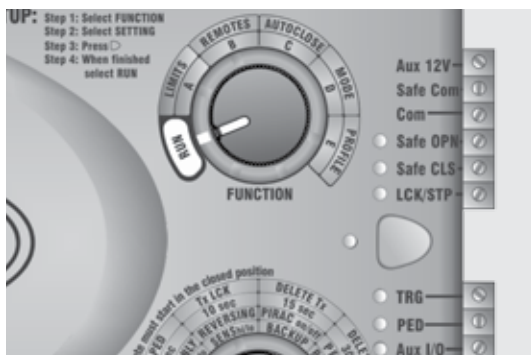

FIGURE 140

Solar

To configure the controller for solar power (controllers manufactured after August 2014 only), please follow the steps below:

Step 1: Rotate the Function Dial to the PROFILE position (E).

Step 2: Rotate the Setting Dial to SOLAR on/off along the 'E' row of options.



FIGURE 141

Step 3: Press the pushbutton to toggle the Solar Profile between On and Off.

The Status LED will change from red to green indicating that the Solar Profile has been activated, or it will change to red indicating that it has been deactivated.



FIGURE 142

Step 4: Return the Function Dial to the RUN position.



FIGURE 143

Should you wish to verify your settings you can rotate the Function Dial to the function that you want to check the settings of. Then rotate the Setting Dial to the various selection options. The status LED will light up as green to indicate that the selected option is either On or High; or alternatively red to indicate Off or Low.

Reverting to Factory Defaults

It is possible to clear and default the system completely, resetting all programmed settings to default values and clearing all learned remotes as well as gate limits.

To perform a complete reset:





- Remove power from the unit by disconnecting both the mains supply and one battery terminal
- Press and hold the pushbutton
- Reapply power to the unit (it makes no difference whether the battery or mains is reconnected first)
- Release the pushbutton
- The controller is now defaulted



Reverting to Factory Defaults

Parameter description	Unit	Minimum	Default	Maximum
Sensitivity	Hi/Lo	Lo	Hi	Hi
Autoclose status	On/Off		Off	
Autoclose timer	s	15s	Off	45s
Modes of Operation	S, O, R		S	
PIRAC	On/Off		Off	
PCM status	On/Off		Off	
Speed	Hi/Lo	Lo	Hi	Hi
Light profile	CUR, PFA, PFC		CUR	

TABLE 2

15. Description of Terminal Functions

Motor	Motor output – connects to the Blue or Brown motor wire.
Motor	Motor output – connects to the Blue or Brown motor wire.
Batt +	Positive battery connection.  Battery terminal normally indicated as + or red (right-hand battery)
Batt -	Negative battery connection.  Battery terminal normally indicated as - or black (right-hand battery)
COM	The common termination point. All trigger signals, etc. have their return path to one of the COM terminals.
PED	Pedestrian Opening input. (A normally-open potential-free input). Momentarily connecting this input to COM will cause the gate to open to the Pedestrian open position. For more information refer to the Pedestrian feature.
TRG	Trigger input. (A normally-open potential-free input) Momentarily connecting this input to COM will cause the gate to open or close depending on the operating mode selected. For more information see the Autoclose feature and Modes of Operation.
LCK/STP	Holiday Lockout or gate Stop input. (A normally-closed potential-free input). For as long as a connection between this input and COM is maintained the controller will behave normally. But, when this connection to COM is broken all inputs are inhibited and all triggers except the one that invoked the feature will be ignored, and if the gate is moving it will stop. As the name implies, this feature is mostly used in situations where the premises will be left uninhabited for a period of time, for example when the residents go away on holiday, and electronically locks the entire system for added security. While this is usually a remote control button, other typical devices include a pushbutton, keypad, keyswitch and any number of access control devices.  If this input is enabled while the gate is moving or in the open position, it will only activate and inhibit operation of all the inputs when the gate is back in the closed position  If the LCK function is not required a link must be fitted between LCK and COM*(refer to note on page 80)

Safe OPN	<p>OPENING edge safety input. (A normally-closed potential-free input). As long as a connection between this input and COM is maintained the controller will behave normally. When this connection is broken it will prevent the gate from opening if it is stationary, and will stop and reverse the gate if it is opening. This input has no effect if the gate is closing.</p> <p>If the Safe OPN function is not required a link must be fitted between safe OPE and COM for the controller to operate normally. When setting up the controller for the first time or after a full reset back to factory default has been performed, the system will electronically override the Safety Inputs and allow the system to function without the links. However, if safeties are connected to either or both inputs, thereafter there must be a normally-closed circuit maintained for the system to operate correctly. I.e. if beams are fitted and then removed, the circuit which is affected must be replaced with a wire link to create the normally-closed circuit.</p> 
Safe CLS	<p>CLOSING edge safety input. (A normally-closed potential-free input). As long as a connection between this input and COM is maintained the controller will behave normally. When this connection is broken it will prevent the gate from closing if it is stationary, and will stop and reverse the gate if it is closing. This input has no effect if the gate is opening.</p> <p>If the Saf CLS function is not required a link must be fitted between Safe CLS and COM for the controller to operate normally.) When setting up the controller for the first time or after a full reset back to factory defaults has been performed, the system will electronically override the Safety Inputs and allow the system to function without the links. However, if safeties are connected to either or both inputs, thereafter there must be a normally-closed circuit maintained for the system to operate correctly. I.e. if beams are fitted and then removed, the circuit which is affected must be replaced with a wire link to create the normally-closed circuit.</p> 
LED	<p>External gate status indicator. (A low-current output signal.) An output terminal which provides a low-drive (approx. 4,5V DC, 20mA) to an LED which can be used to indicate the gate status remotely. If more than three LEDs are required it is necessary to fit the CP78 MULTI-LED driver card.</p>
Aux 12V	<p>Auxiliary power connection. Provides a +12V DC supply for auxiliary equipment such as a radio receiver, Safety Beam(s) etc. It is linked directly to the battery positive via a 3A resettable fuse.</p>
Safe Common	<p>Used for switching the power supply to the Safety Beam(s). If automatic beam testing is required, the negative power supply connection of the beam transmitters must be wired to this point.</p>



When setting up the controller for the first time or after a full reset back to factory default has been performed, the system will electronically override the Safety Inputs and allow the system to function without the links. However, if safeties are connected to either or both inputs thereafter, there must be a normally-closed circuit maintained for the system to operate correctly. I.e. if beams are fitted and then removed, the circuit which is affected must be replaced with a wire link to create the normally-closed circuit.

16. Diagnostics

Diagnostic LEDs

The D2 Turbo controller has a series of diagnostic LEDs which indicate the state of the inputs. Normally-open inputs are indicated by a RED LED, and normally-closed inputs by a GREEN LED. An illuminated RED LED indicates that the signal is present (e.g. intercom button pressed), while an illuminated GREEN LED indicates that the signal is absent (e.g. infrared Safety Beam not broken).

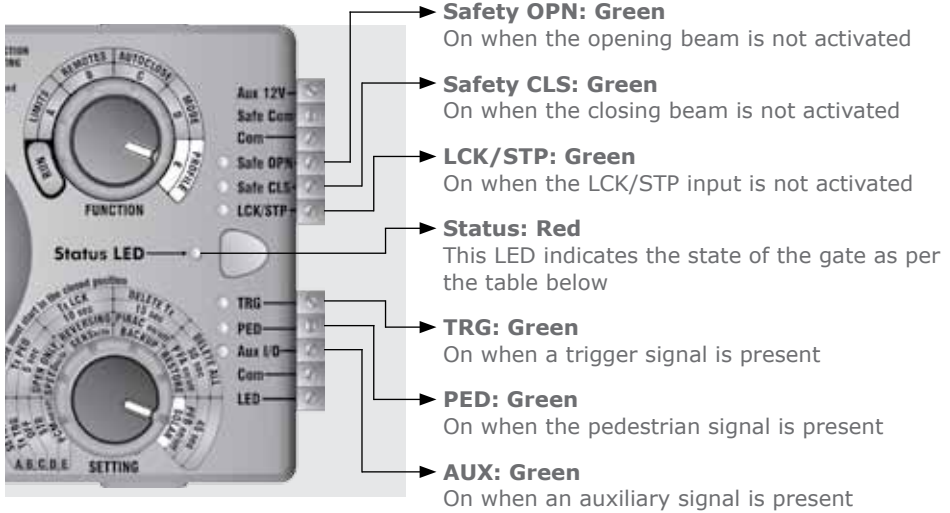

Buzzer feedback

A warning buzzer will sound (where applicable) as per the table below:

Inhibitor name	Priority	Number of beeps	Fault type	Gate continues to operate	User can correct error
Battery-low	1	3 beeps every two seconds for 30 seconds	Power system fault	Yes ¹	Yes
Multiple collisions	2	Periodic until condition is cleared by user	Collision	No	Yes
Holiday Lockout	3	3 beeps periodically for 30 seconds	User	No	Yes
Mains failure	4	2 beeps every two seconds for 30 seconds	Power system fault	Yes	Yes
Beams broken (any)	5	1 beep periodically for 30 seconds	User	No	Yes
Beams broken (any)	6	3 beeps each time the gate is triggered	User	No	Yes

1. Gate will close fully and then shutdown for two minutes

TABLE 3

17. Troubleshooting

Problem	Possible faults
Gate does not move	<ul style="list-style-type: none"> • Fuse is blown – Check 30A ATO fuse, and replace if necessary • LCK (Holiday lockout) input activated. Green LCK light should be ON • IRBC/IRBO (IR beams) inputs activated • Latching input on TRG. (TRG light must be off for gate to operate) • IRBC - gate will not close once open; IRBO - gate will not open once closed • Green IRBC/IRBO lights should be ON - • Check the battery condition with Procedure A: Low battery voltage condition, later in this section
Gate moves a short distance, and then stops	<ul style="list-style-type: none"> • Procedure B: False collision detection, later in this section • If the problem persists, the main controller might be faulty • If Status light flashes four times, then the operator is in Multiple Collision Mode. If required, check with • Check the battery condition with Procedure A: Low battery voltage condition, especially if the Status Light flashes three times • Check for false collisions with Procedure B: False Collision Detection, later in this section • Intermittent IRBC/IRBO signals. Check that the voltage applied to the beams is appropriate • False trigger. Intermittent short due to possible moisture on the TRG input. Monitor TRG LED
Gate starts closing, then stops and re-opens	<ul style="list-style-type: none"> • If the problem is still not solved, the main controller might be faulty
Gate overrides its limits	<ul style="list-style-type: none"> • Check collision sensitivity and other causes with Procedure B: False Collision Detection • Besides a faulty controller, which will be considered last, the only factor that could cause this symptom is a missing origin or faulty DOSS module • However, initially before the gate overrides its limits, if the origin is not detected, the controller will automatically start beeping when the gate is running, but it will allow normal operation.

Gate overrides its limits	<p>Check for the following:</p> <ul style="list-style-type: none"> • Check that the origin marker is correctly positioned as shown on page 38 • Check that the DOSS sensor harness is properly plugged into the magnetic switch at one end and the controller at the other • Carefully check the condition of the harness. • Look out for any bad crimp joints between the wires and the connectors at both ends of the harness • Check that the magnetic switch is mechanically switching. In manual mode, slide the gate backwards and forwards so that the magnet passes the switch each time. Listen out for a distinctive click as the switch operates
Unreliable Autoclose	<ul style="list-style-type: none"> • Check that the respective origin sensor is securely clipped into the housing • Check that the origin magnet is correctly positioned as shown on page 38 • If the problem is not solved, the main controller might be faulty
Gate opens to Pedestrian and closes	<ul style="list-style-type: none"> • Latching receiver on TRG would activate the Autoclose override feature • Long pulse on TRG would activate the Autoclose override feature
Gate opens to Pedestrian and stays open	<ul style="list-style-type: none"> • Faulty IRBC Beam signal • Intermittent power loss, check for low voltages with Procedure A: Low Battery Voltage Condition • If the problem is still not solved, the main controller might be faulty • Intermittent fault on PED (Pedestrian) input. Check wiring, and key switch/keypad operation
Gate opens from the intercom, but not via the remote control	<ul style="list-style-type: none"> • Check Procedure B:False Collision Detection • If the problem is still not solved, the main controller might be faulty • There is a continuous PED signal, the PED light will be on continuously. (The PED light and signal must turn on momentarily for the gate to close after a pedestrian signal.) If an external receiver is operating the PED input, check for an accidentally latching contact, or a faulty keyswitch/ keypad • If the problem is still not solved, the main controller might be faulty

Procedure A - Low-battery voltage condition

Status light flashes three times

If the battery voltage is less than 10.5V, the motor will not operate at all. For any other voltage, the battery could still be the cause of the problem. Check that the battery is being properly charged.

- Check that the mains power is turned ON (measure 90V - 240V AC on the mains connector for the D2 Turbo, or 10V - 20V AC/10V - 28V DC for the D2 Turbo Low-Voltage)
- Check the condition of the battery leads, terminals and connectors. Look for and correct all loose connections and signs of corrosion
- The battery might be discharged. Measure the battery voltage with the charger connected; if the voltage is below 12.5V then the battery is discharged. The number of opening cycles per hour may be excessive, thus discharging the battery. Charge the battery if required
- The onboard charger might be faulty. Disconnect the battery, and measure the voltage on the battery leads.
- It must be between 13.6V and 13.8V. If not, replace the controller
- Battery may be old, and might have to be replaced. If in doubt test as follows:
- Check that the battery is charged by ensuring that the battery voltage is above 13.5V with the onboard charger connected. (If the battery is in a good condition it would probably pass the test without being fully charged)
- Isolate the mains from the controller
- Remove the DC motor leads from the DC Controller
- Apply the DC motor leads directly to the battery, while measuring the battery voltage



First make sure that the moving gate will not pose any danger.

- If the gate does not move, the battery or motor could be faulty
- If the battery voltage remains unchanged, then the motor is faulty and must be serviced. If the battery voltage drops to below 11.2V then the battery must be replaced
- Before replacing the battery, measure the charging voltage on the battery leads with the battery disconnected. It must be between 13.6V and 13.8V. If not, replace the charger.

Procedure B - False collision detection

Status light flashes four times to indicate that number of collisions have exceeded the Collision Counter feature value.

With the operator in Manual Mode, check the following and correct if necessary:

- Check for badly running gate, or something physically obstructing the gate
- Activate the manual override and manually move the gate to check for ease of operation
- Rack pressing down onto pinion
- Bad rack joints
- Seized or badly running wheels
- Top guide-rollers restricting the gate
- Dirt on rail
- Physical damage to the rail
- Wheel catching side of pinion
- Gate hitting endstop
- Check the DC motor wires for loose connections
- Check that the sensor wire harness is securely plugged into controller
- If the problem is not solved, replace the motor module and main controller

18. Manual Operation

Disengage the gearbox/drive

To manually override the operator you will need to:

Open the camlock cover, insert the camlock key and rotate it 90° clockwise (the cover can also be removed at this stage if so desired). This will allow for the rotation of the Manual Release thumbwheel.



FIGURE 144

By turning the Manual Release thumbwheel 90° counter-clockwise until it clicks, the motor pinion will be put into 'Manual Mode'.



FIGURE 145

Re-engage gearbox/drive

To re-engage the drive mechanism of the operator you will need to:

Turn the Manual Release thumbwheel 90° clockwise until it clicks.

Once you have re-engaged the drive mechanism, don't forget to lock the camlock by inserting the key and rotating it 90° counter-clockwise – this will help prevent unauthorised tampering with the operator.



FIGURE 146

19. Additional Features

Battery saver

In the event of a battery-low shutdown, only the motor will stop drawing current – the controller, infrared beams and any other peripheral devices will continue to flatten the battery; however, at a much slower rate.

An optional low cut-out switch (product code CP107) totally disconnects the battery and protects it from being fully discharged and potentially damaged.

Consult your gate automation specialist for further details.



FIGURE 147

Solar power supply

A solar panel can be used to charge the battery instead of the conventional charging circuit. A 20W panel will provide enough power for 20 daily operations of an average gate (less if 12V DC security lights are fitted).

You will need to fit a deep-cycle low-maintenance battery (minimum 35Ah) in order to provide sufficient backup capacity during days of poor weather.

These are typical values for Southern Africa. Contact your gate automation specialist for details on what solar panel to select in your area.

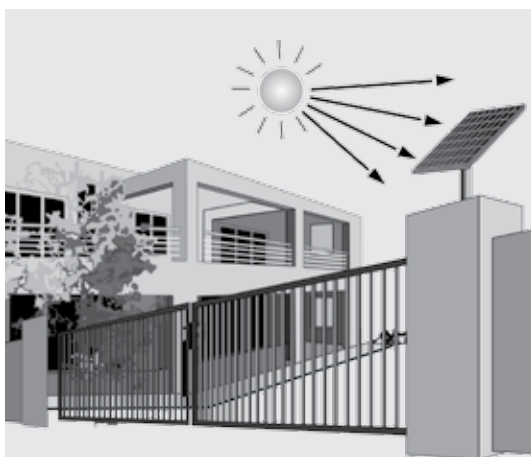

FIGURE 148

Refer to Figure 66 and 67 on pages 49 and 50 for instructions on how to connect a solar panel to your D2 Turbo/D2 Turbo Low-Voltage operator.



The mains fail buzzer can be disabled by selecting the Solar Profile option (controllers manufactured after August 2014 only). Refer to 'Customising the Features and Functions' on page 65 for details.

20. Basic Maintenance

Our operators are designed to be maintenance-free. However, there are some basic checks that should be carried out regularly (every six months). These checks will increase the long-term reliability of the system and prevent erratic operation of your gate.



Isolate mains supply to system before cleaning or working on the equipment

General

Even if the user has used a gate operator before, it does not mean that he knows how to SAFELY operate it. Make sure that the user fully understands the following safety requirements before finally handing over the site.

Show the user how to do the following:

- Keep the track clear of stones, dirt and obstructions
- Ensure that all rollers run freely
- Put the operator into Manual Mode and check that the gate runs freely on its rail and does not catch or foul against the walls or pillars
- Ensure that the gate wheels and guide-rollers are rotating freely and are not worn. In high-volume applications it will be necessary to replace these components regularly
- Ensure that the rack is properly secured to the gate and that it does not press down onto the operator pinion at any point along its travel
- Keep shrubs and vegetation clear of the motor and rack
- Check that the key still operates the camlock - spray with lubrication if necessary
- Keep the inside of the motor housing clean
- The operators are fitted with high-quality, maintenance-free lead acid batteries which should provide up to three years of normal service life.
- Check for corrosion of the battery terminals
- Clean and apply copper-based grease as necessary

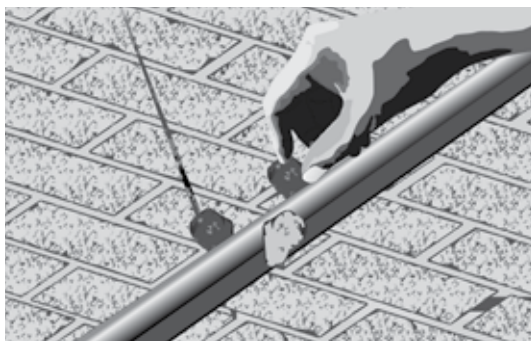

FIGURE 149



FIGURE 150

21. Servicing the Operator

Refer all servicing to qualified service personnel. Consult your local dealer for assistance.

Your D2 Turbo sliding gate operator requires no special care other than that described in the Maintenance section. If you are having a problem with your D2 Turbo, please contact your installer or local dealer.

22. 24 Month Carry-in Product Warranty



You can register your product(s) online at www.CentSys.co.za, which will assist you in keeping a record of your date of purchase or installation, serial numbers, etc.

All of our products are manufactured with extreme care, thoroughly inspected and tested.

The goods supplied by us shall be subject to the provisions of sections 55 to 57 of the Consumer Protection Act (68/2008) except where the provisions of the warranty contained in our product documentation are more favourable to the purchaser. Subject to the warranty contained in our product documentation, if applicable, our products are warranted for a period of twenty-four months after delivery. However, it is expressly noted that batteries carry a six month warranty due to the nature of these products being such that they are subject to possible misuse. Please note that warranties will be honoured on a carry-in basis; in other words, the product in question must be taken in to one of our branches, or to the authorised reseller that the product was purchased from, for assessment and, if necessary, repair. For equipment not of our manufacture, the warranty as supplied by the original manufacturer will apply if such warranty is more favourable to the purchaser than the relevant provisions of the Consumer Protection Act (Act 68/2008 of South Africa), or any other applicable law as so required in different countries in which the product was sold. Such warranty is valid only once full payment has been received for such goods.

Australian customers:

Our goods come with guarantees that cannot be excluded under the Australian Consumer Law. You are entitled to a replacement or refund for a major failure and compensation for any other reasonably foreseeable loss or damage. You are also entitled to have the goods repaired or replaced if the goods fail to be of acceptable quality and the failure does not amount to a major failure

Any warranty may be voidable on any equipment which:

1. Has not been installed in accordance with the installation instructions provided.
2. Has been subject to misuse or which has been used for any purpose other than that designed for by the manufacturers.
3. Has damage caused as a result of handling during transit, atmospheric conditions (including lightning), corrosion of metal parts, insect infestation, power surges or other forces outside of the control of the manufacturer.
4. Has been repaired by any workshop and / or person NOT previously authorised by the manufacturer.
5. Has been repaired with components not previously tested, passed or authorised by Centurion Systems (Pty) Ltd, South Africa or one of its subsidiary companies.

Any warranty may be voidable on any equipment which:

1. There has been a failure to install the product in accordance with the installation instructions provided by the manufacturer, or
2. A failure to abide by the safety instructions provided by the manufacturer, or

3. There is no breach of a legal duty of care owed to you by us or by any of our employees or agents.
4. Such loss or damage is not a reasonably foreseeable result of any such breach, and any increase in loss or damage resulting from breach by you of any term of this contract.

23. Installation Handover

Once the installation has been successfully completed and tested, it is important for the installer to explain the operation and safety requirements of the system.



Never assume the user knows how to safely operate an automated gate!

Even if the user has used a gate operator before, it does not mean he knows how to SAFELY operate it. Make sure that the user fully understands the following safety requirements before finally handing over the site.

1. The following needs to be understood by the user:
 - How to operate the Manual Release thumbwheel mechanism.
(Show them how by demonstration)
 - How the obstruction detection and all other safety features work.
(Show them how by demonstration)
 - All the features and benefits of the operator, i.e. Safety Beams, etc.
 - All the safety considerations associated with operating an automated gate. The user should be able to pass this knowledge on to all other users of the automated system and must be made aware of this responsibility
- Do not activate the gate operator unless you can see it and can determine that its area of travel is clear of people, pets, or other obstructions
 - NO ONE MAY CROSS THE PATH OF A MOVING GATE. Always keep people and objects away from the gate and its area of travel
 - NEVER LET CHILDREN OPERATE OR PLAY WITH THE GATE CONTROLS, and do not allow children or pets near the gate area
 - Be careful with moving parts and avoid close proximity to areas where fingers or hands could be pinched
 - Secure all easily-accessed gate operator controls in order to prevent unauthorised use of the gate
 - Keep the automated gate system properly maintained, and ensure that all working areas are free of debris and other objects that could affect the gate operation and safety
 - On a monthly basis, check the obstruction detection system and safety devices for correct operation
 - All repair and service work to this product must be done by a suitably qualified person
 - This product was designed and built strictly for the use indicated in this documentation. Any other use, not expressly indicated here, could compromise the good condition/operation of the product and/or be a source of danger!

Neither Centurion Systems (Pty) Ltd, nor any of its subsidiaries, accepts any liability caused by improper use of the product, or for use other than that for which the automated system was designed.

Ensure that the customer is in possession of the User Guide and that you have completed the installation details in the back of the User Guide.

Once the installation has been successfully completed and tested, it is important for the installer to explain the operation and safety requirements of the system.



Connect with us on:

 facebook.com/CenturionSystems

 YouTube.com/CenturionSystems

 [@askCenturion](https://twitter.com/askCenturion)

Subscribe to the newsletter: www.CentSys.com/Subscribe

Call Centurion Systems (Pty) Ltd • South Africa
Head Office: +27 11 699 2400

Call Technical Support: +27 11 699 2481
from 07h00 to 18h00 (UTC+2)



Doc number: 0.07.D.0038_21042015 ENGLISH

www.CentSys.com