

ROLL-UP DOOR OPENER



INSTALLATION MANUAL

IMPORTANT SAFETY RECOMMENDATIONS

FAILURE TO COMPLY WITH THE FOLLOWING SAFETY RECOMMENDATIONS MAY RESULT IN SERIOUS PERSONAL INJURY, DEATH AND/OR PROPERTY DAMAGE.

1. **READ AND FOLLOW ALL SAFETY AND INSTALLATION INSTRUCTIONS CAREFULLY.**
2. **The installation of your new Automatic Garage Door Opener (herein after referred to as “RDO”) must be carried out by a technically qualified or licensed person. Attempting to install your new RDO without suitable technical qualification may result in severe personal injury, death and/or property damage.**
3. Only install the RDO on a properly balanced and aligned, well functioning Garage Door. An improperly balanced or malfunctioning Garage Door could cause serious injury. Have a qualified person check and if required, make repairs to your Garage Door **before** installing the RDO. As a general rule, your Garage Door is deemed to be well balanced and aligned if it
 - a. requires an equivalent amount of applied force to manually open or close and,
 - b. requires no more than 150N of applied force to either manually open or close and,
 - c. does not rise or fall more than 100mm when stopped at any position between fully open or fully closed positions and,
 - d. does not rub on or make contact with any supporting or surrounding structures.
4. Repairs to Garage Doors must only be carried out by technically qualified persons. Attempting to repair the Garage Door without suitable technical qualification may result in severe personal injury, death and/or property damage.
5. Remove or render inoperative all existing locks and ropes prior to installation of the RDO.
6. The counter balance springs on sectional type doors **must** be properly lubricated between all of the coils with heavy automotive bearing grease. Failure to adequately lubricate the springs may result in one or more of the following symptoms;
 - a. The springs will become rusty over time resulting in extra operating friction between the coils which may cause the RDO to malfunction.
 - b. Seasonal temperature changes may cause the Garage Door springs to expand and/or contract. The resultant increase and/or decrease in operating friction may cause the RDO to malfunction. Properly lubricating the springs will help to minimize the effect of seasonal temperature changes in operating friction of your Garage Door.
7. If possible, install the RDO at least 2 meters or more above the ground. Adjust the Manual Release Cord so that it hangs approximately 1.8 meters from the ground.
8. Do not connect the RDO to the power source until this manual instructs you to do so.
9. The RDO must be connected to a **properly earthed** general purpose 220V outlet which has been installed by a qualified electrical contractor.
10. Locate the wall control panel/push button;
 - a. within site of the Garage Door and,
 - b. at a minimum height of 1.5 meters above the ground so that it remains out of the reach of small children and,
 - c. away from all moving parts of the door.
11. Install the Entrapment Warning Label in a prominent position next to the wall control button.
12. The Manual Release Instruction Tag must remain attached to the Manual Release Cord.
13. After installing and correctly adjusting the RDO, the Garage Door **must** stop and reverse direction when it comes into contact with a 35mm high solid object placed on the floor under the Garage Door.
14. The correct function of the Safety Obstruction Reversing System should be checked on a monthly basis. Make sure that the Garage Door reverses when it makes contact with an obstruction.

IMPORTANT SAFETY RECOMMENDATIONS

15. Never use the RDO unless the Garage Door is in full view and free from objects such as cars, children and/or adults.
16. Never allow children to operate the RDO.
17. Never operate the RDO when children/persons are under or near the path of the door. Children **must** be supervised at all times when near the Garage Door and when the RDO is in use.
18. Never attempt to disengage the RDO to manual operation when there are children/persons or and other objects including motor vehicles under or near the path of the Garage Door.
19. Never attempt to open or close the Garage Door by pulling on the Manual Release Cord.
20. Never attempt to make any repairs or remove covers from the RDO without first disconnecting the power supply cord from main power supply.
21. For additional safety we strongly recommend the fitment of Safety Beams. Although the RDO incorporates a pressure sensitive safety obstruction system, the addition of Safety Beams will greatly enhance the operating safety of the Automatic Garage Door and provide additional peace of mind. In some countries it is mandatory by law to fit Safety Beams. It is the sole responsibility of the owner/installer to fit Safety Beams in those countries which so require.
22. Removal of the RDO's protective covers must only be performed by a technically qualified person. Attempting to remove the protective covers or repair the RDO without suitable technical qualification may result in severe personal injury, death and/or property damage.
23. Always ensure that the Garage Door is fully open before driving into or out of the Garage.
24. Always ensure the Garage Door is fully closed before leaving the driveway.
25. Adjustments to the Safety Obstruction Force settings must only be carried out by a technically qualified person. Attempting to adjust the Safety Reverse Force setting without suitable technical qualification may result in severe personal injury, death and/or property damage.
26. Keep hands and loose clothing clear of the Garage Door and Product at all times.
27. In order for the Safety Obstruction Force System to function it must first encounter an object/person on to which some force **MUST** be exerted. As a result the object/person/door may suffer **DAMAGE OR INJURY**.
28. **The Safety Obstruction Force System is designed to work on STATIONARY objects only. If the Garage Door encounters a moving object during an Open or Close Cycle, serious personal injury, death and/or property damage may occur.**

PRODUCT GUARANTEE AND EXCLUSIONS

All CENTURION products are manufactured with extreme care, thoroughly inspected and tested. The products are only guaranteed against faulty materials and workmanship for a period of 12 months from the invoice date of the product or 14 months from the manufacturing date (as shown on the serial number label of the operator), whichever expires first.

The guarantee will cover the repair or replacement at our discretion of such faulty materials or parts free of charge provided that the equipment is returned to our workshop.

No claims whatsoever will be recognised under the terms of this guarantee which pertain to damage, injury, cost or expense, suffered by persons and / or to property, which either directly or indirectly arise out of any one of the following occurrences:-

- a. Failure to install the product in accordance with the installation instructions.
- b. Failure to abide by the safety instructions provided in this manual.

This guarantee will not apply to any equipment which:

- c. Has not been installed in accordance with the installation instructions provided.
- d. Has been subject to misuse or which has been used for any purpose other than designed for by the manufacturers.
- e. Has damage caused as a result of handling during transit, atmospheric conditions, insect infestation, power surges or other forces outside our control.
- f. Has been repaired by any workshop and / or person NOT previously authorised by CENTURION SYSTEMS.
- g. Has been repaired with components not previously tested, passed or authorised by CENTURION SYSTEMS.

OPERATING CONTROLS

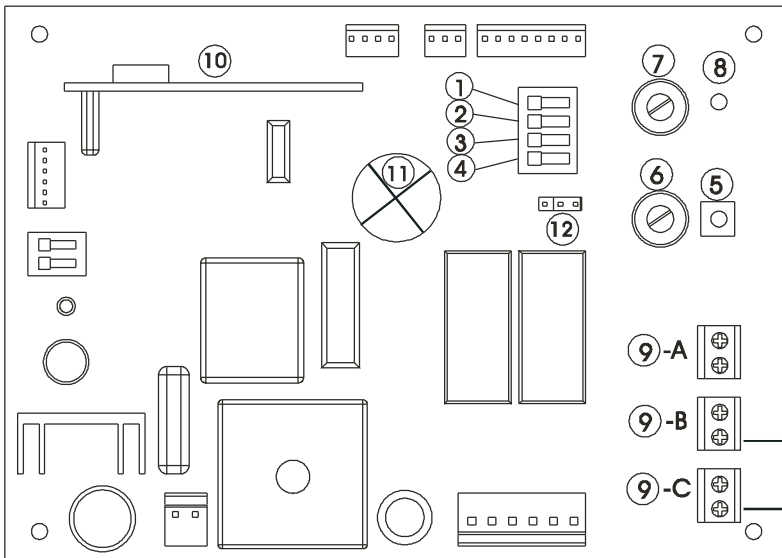

Fig 1

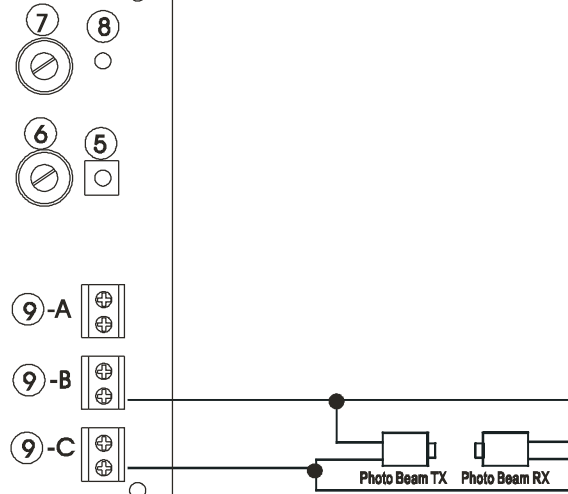
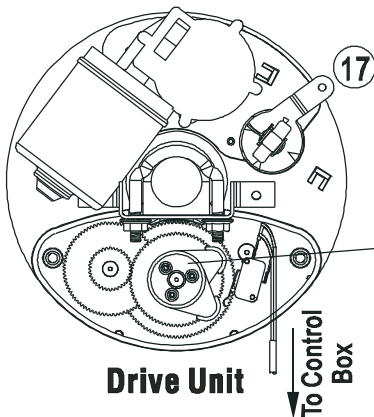

Fig 1A



Drive Unit

Fig 2

To Control Box

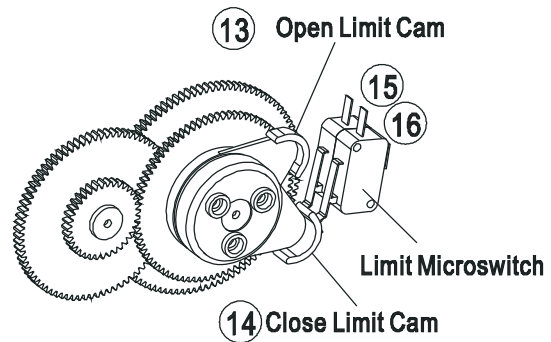

Limit Set

Fig 2A

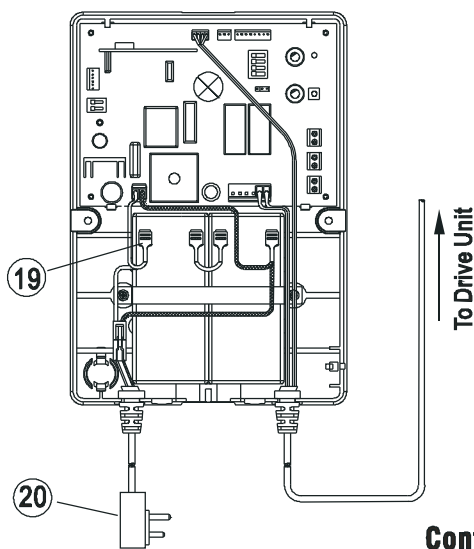

Fig 3

Control Box

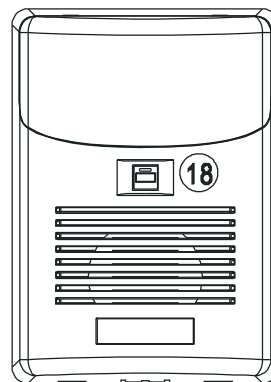
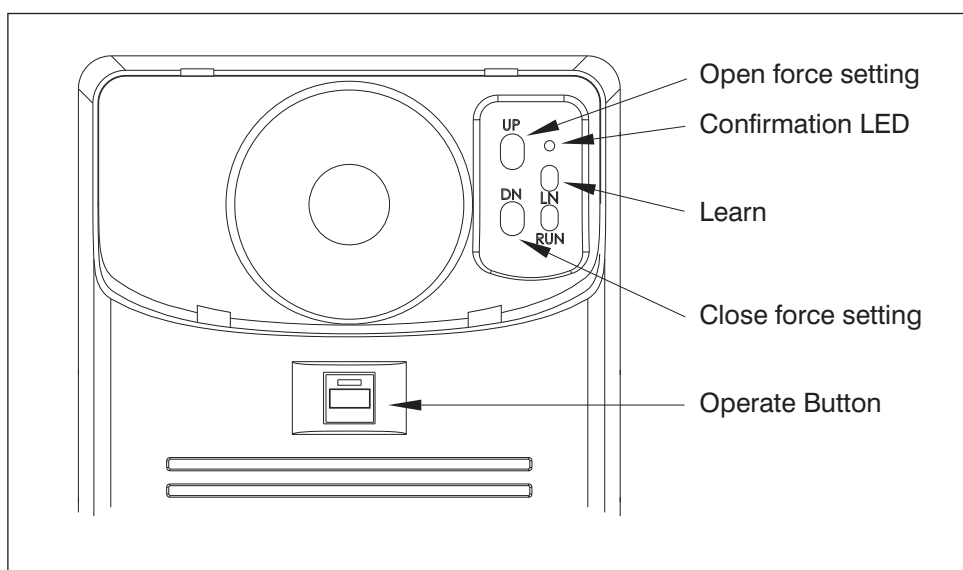

Fig 3A

OPERATING CONTROLS

1. **INFRARED SAFETY BEAM ENABLE DIP SWITCH.** (refer Sec.18)
2. **AUTO CLOSE ENABLE DIP SWITCH.** (refer Sec.21)
3. **AUTO CLOSE DELAY DIP SWITCHES** are used to adjust the time to auto close. (refer Sec.21)
4. **SAME AS ABOVE**
5. **CODE BUTTON** used for storing or erasing transmitter security code (refer Sec.15) (Does not apply if kit supplied with **NOVA VOYAGER** receiver)
6. **CLOSE DIRECTION SAFETY OBSTRUCTION FORCE ADJUSTMENT SCREW** is used to adjust the Safety Obstruction Force value in the Open Direction (refer Sec.11 & 13)
7. **OPEN DIRECTION SAFETY OBSTRUCTION FORCE ADJUSTMENT SCREW** is used to adjust the Safety Obstruction Force value in the Close Direction (refer Sec.12 & 14)
8. **CODE LAMP** signals stages of transmitter code learning process (refer Sec.15)
9. **OUTPUT TERMINALS** for connection of infrared safety beams or remote mounted push button. (refer Sec.17, 18 & 22)
10. **RADIO RECEIVER** processes the signal from the hand held transmitter. (Does not apply if kit supplied with **NOVA VOYAGER** receiver)
11. **AUTO COURTESY LIGHT** is activated automatically each time the opener commences an open or close cycle and remains on for approx 3 minutes.
12. **JUMPER PLUG (J8)** switches power supply for use with either one of Safety Beams or external Receiver. (refer Sec.18)
15. **OPEN LIMIT CAM** is used to adjust the door fully open position. (refer Sec.7 & 10)
14. **CLOSE LIMIT CAM** is used to adjust the door fully closed position. (refer Sec.8 & 10)
16. **OPEN LIMIT MICRO SWITCH** is used to stop door when it reaches the fully open position.
16. **CLOSE LIMIT MICRO SWITCH** is used to stop the door once it reaches the fully closed position.
17. **ENGAGE/DISENGAGE LEVER** engages/disengages opener from the door. (refer Sec.4)
18. **EXTERNAL PUSH BUTTON** alternatively opens, closes or stops the door when activated.
19. **POSITIVE BATTERY CABLE**
20. **PLUG PACK BATTERY CHARGER**



REQUIREMENTS PRIOR TO INSTALLATION

A. Forward

Your RDO is comprised of 2 major individual components being, Drive Unit (top figure alongside) and Control Box (bottom figure alongside). This section of the manual deals with the basic fitting requirements which should be met **before** you attempt to install your opener. Study them carefully to ensure that your door and surroundings are suitable for such an installation.

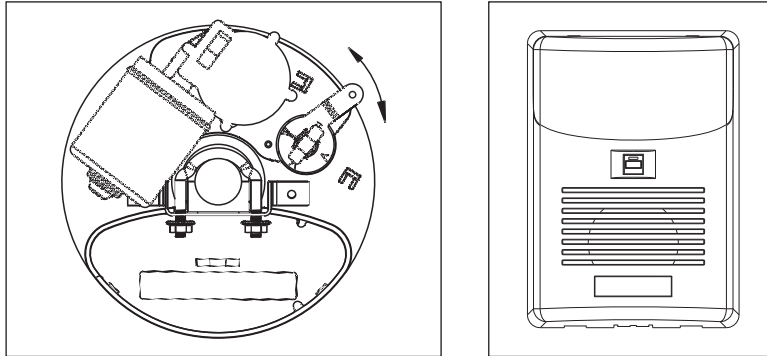

Important Note: The procedures outlined in this manual require a certain degree of technical and mechanical skill. It is not recommended that your RDO be installed by a home handyman. The RDO should always be installed, serviced and adjusted by a technically qualified person.

B. Side Room Requirement

The recommended minimum and maximum door mounting bracket position as measured from the edge of the garage door curtain is depicted in Fig.5. The ideal distance should be between 85~125mm as indicated.

Important Notes:

- The fixing distance may vary from garage door to garage door depending on the distance that the garage door drum wheel has been set inside the garage door curtain.
- If the door drum wheel has been set too deep inside the garage door curtain it is recommended to fit an additional drum wheel closer to the edge of the curtain facilitating easier installation of the RDO unit.
- The installer should verify the correct distance by actually checking the measurement prior to mounting or moving any garage door brackets.

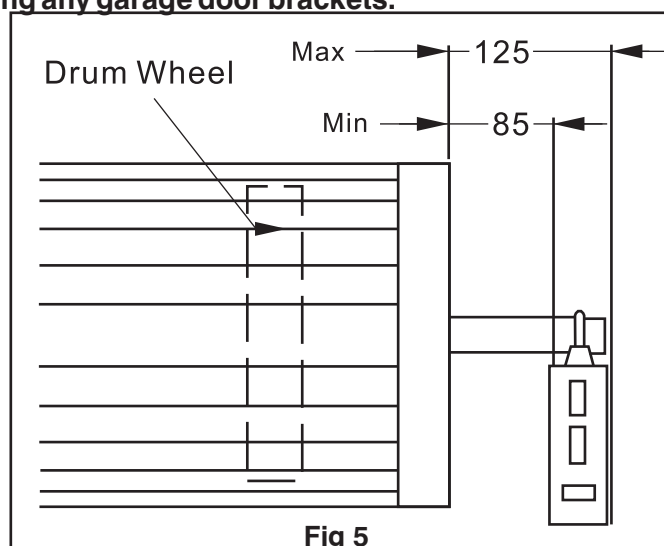

Fig 5

REQUIREMENTS PRIOR TO INSTALLATION

C. Check For Correct Function Of The Door

Before beginning the installation of the RDO check that the garage door is functioning correctly. The garage door must be well balanced and operate smoothly and freely. When opened to between 900~1200mm from the floor and released the garage door should remain in one fixed position and not rise or fall more than 100mm. It should not bind or stick in the side tracks. The ideal operational effort required to open or close the garage door should not exceed a force of 15kg. (Refer Item 3, Page 1)

Important Note: The RDO must not be installed on a poorly adjusted, worn or damaged door.

D. Weight Bar

The main purpose of the weight bar is to eliminate the possibility of the garage door curtain “ballooning” when starting from the fully open position. With the weight bar fitted the garage door should have a natural tendency to lightly free fall from the mid open position.

E. Left Or Right Hand Installation

The RDO has been factory set to be installed on the right hand end of your garage door (when viewed from inside the garage looking out). If the left hand side is the preferred side for installation then carry out the procedure outlined in Section F below - otherwise skip section F and go directly to Section G.

F. Converting For Right Hand Installation

Locate the red and black motor wires. (Fig.6) The standard connection (Black to Black and Red to Red) must be reversed. Unplug the wires at the connectors and reverse them so that they are connected Red to Black and Black to Red.

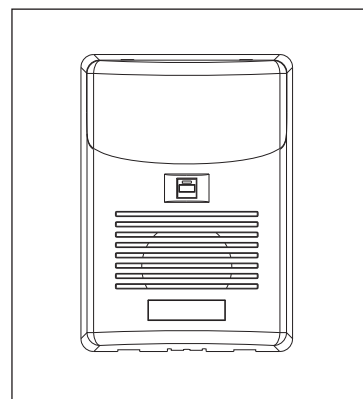
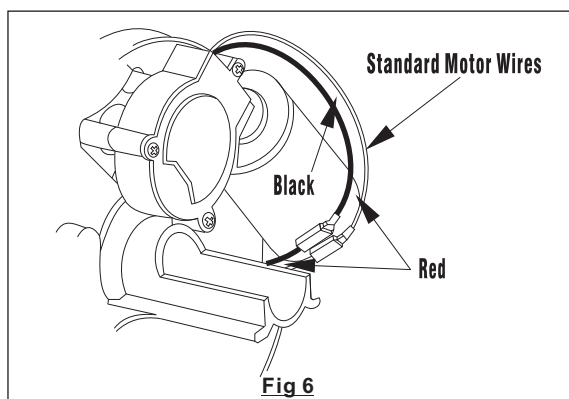

G. Control Box Location

Mount the Control Box on a smooth flat surface. The area must be completely free of exposure to water, either direct (rain, garden hose, sprinklers etc) or indirect (seepage either through or down the internal face of the wall). The Control Box contains sensitive electronics which will sustain damage as a result of **any** water intrusion. Water damaged electronics are not covered under the terms of the opener warranty.

Important Note: The control box is not water proof!

REQUIREMENTS PRIOR TO INSTALLATION

H. Battery Charger

The plug-in battery charger is provided to keep the batteries charged to an optimum voltage. A red coloured LED, located on the charger casing will illuminate to indicate that the charger has been connected to an active power supply.

Important Note: Do not mount the charger any further away from the control box than the connection cable allows. Please ensure that a 220V mains point is provided at the control box for the charger.

I. Battery Cable Connection

In order to conserve battery power prior to installation, the RDO is supplied with the positive (red) battery cable disconnected from the battery terminal. Connect this cable prior to commencing the installation as follows:-

Remove the Control Box lid and connect the red cable to the positive (+) battery terminal as depicted in Figure below Item 19. Once connected the lid can be refitted.

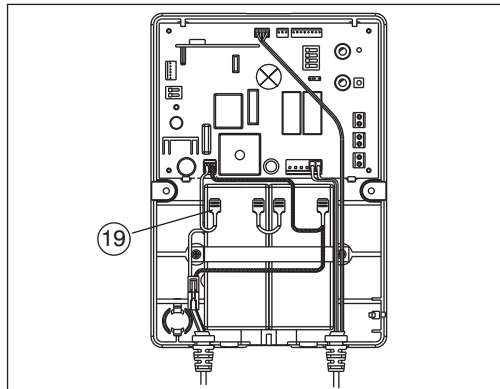

INSTALLATION INSTRUCTIONS

1. Mounting The Control Box

- 1.1 Establish a location at approximately chest height on the same wall face as that of the Door Mounting Bracket to which Drive Unit will be secured. Make sure that the cable running from the Control Box is long enough to reach up to the Drive Unit for the location that has been selected.
- 1.2 Use the Mounting Template provided on last page of this manual, mark the location of the 3 Control Box mounting screws.
- 1.3 Drill a 6mm hole at each of the 3 marked locations to an approx depth of 75mm.
- 1.4 Insert a green wall plug (provided) into each of the 3 holes.
- 1.5 Insert a self tapping screw (provided) into each of the green plugs and leave the heads exposed from the wall approx 6mm.
- 1.6 Locate the 3 recessed mounting slots on the center back of the Control Box base plate and “hook” the Control Box onto the screws Note: The mounting screws may need to be adjusted for depth if the Control Box will not hook on to the screws or if the Control Box does hook on but is loose.
- 1.7 At this stage, DO NOT plug the Charger into a power socket.

INSTALLATION INSTRUCTIONS

2. Fitting Of Drive Unit To The Door (Right Hand Installation Depicted)

- 2.1 Check that the door U-bolt is securely tightened on the opposite end of the door to which the Drive Unit will be fitted (Fig.7)
- 2.2 Open the door fully and ensure that the bottom stoppers of the Garage Door are engaged with the stoppers on the door guide tracks.
- 2.3 Place a suitable prop under the door as close to the edge (to which the drive unit is being fitted) as possible. The prop should be adjusted so that it sits firmly under the door. (Fig.8)
- 2.4 **Important Note: The door curtain can become damaged quite easily once the full weight of the door is imparted on the prop. The prop must be strong enough to sustain the full weight of the door but at the same time have enough padding that it will not damage the door curtain. The suitability of the prop should be determined by a technically qualified person. No claims for door damaged will be recognized under the terms of the RDO's guarantee when using an unsuitable prop.**

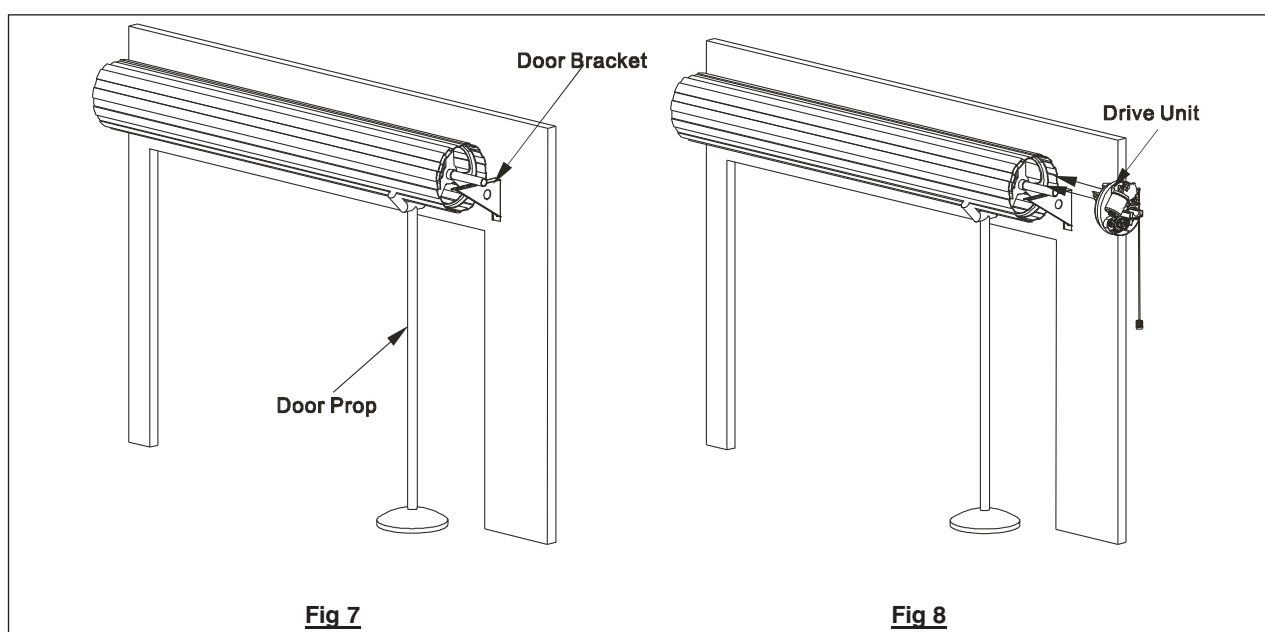

- 2.5 Remove the U-bolt from the end of the garage door to which the Drive Unit will be fitted.
- 2.6 Having ensured that the prop is stable and firmly in position, remove the garage door mounting bracket from the wall.
- 2.7 If not already disengaged then disengage the RDO Drive Unit by pulling once on the release lever (Fig.11) - the forked drive gear should now rotate freely.
- 2.8 Orientate the Drive Unit as per Fig.9.
- 2.9 Slide the centre of the Drive Unit over the garage door axle. Push the Drive Unit fully into the garage door and ensure that one of the garage door drum wheel spokes slides **in between** the forks of the Drive Unit.
- 2.10 Refit the garage door mounting bracket to the wall. The U-Bolt slots in the door bracket must align with the U-bolt mounting slots in the Drive Unit. (Fig.10)
- 2.11 **Important Note: In some cases the door mounting bracket may need to be re-positioned in order that the U-Bolt holes align.**
- 2.12 Fully insert the specially supplied U-bolt through the Drive Unit and garage door mounting bracket slots.
- 2.13 Affix and firmly tighten the U-Bolt with the 2 securing nuts provided.
- 2.14 Check the manual operation of the door by fully raising and lowering the door. The door should run smoothly and should not catch on any part of the Drive Unit assembly.

INSTALLATION INSTRUCTIONS

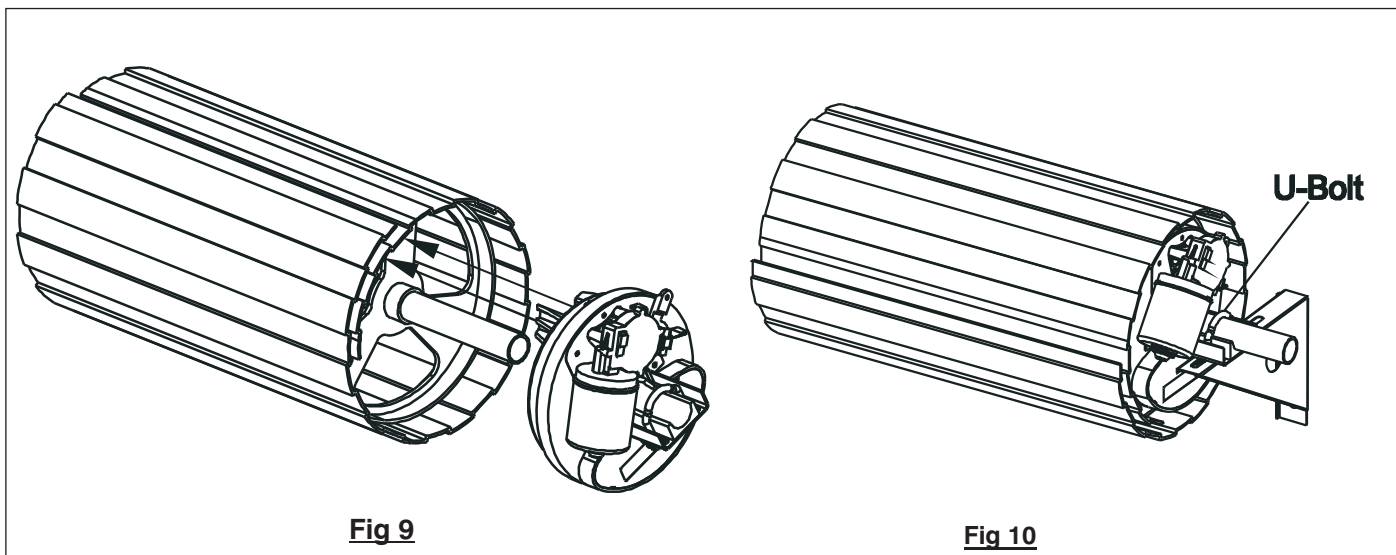

3. Adjusting Release Cord

- 3.1 Unfurl the Red Disengage Cord and cut it to an appropriate length so that its end hangs approximately 1800mm above the garage floor.

4. Engaging And Disengaging The Drive Unit

- 4.1 To disengage the Drive Unit from the garage door pull down on the Red Release Cord. (Fig. 11)
4.2 To engage the Drive Unit to the garage door pull down once more on the Red Release Cord.
4.3 **Important Note: Always disengage the Drive Unit with the garage door in the fully closed position.**
4.4 **Important Note: If attempting to disengage the Drive Unit from any position other than with the garage door fully closed ensure that there are no persons and/or property near or directly under the path of the garage door.**

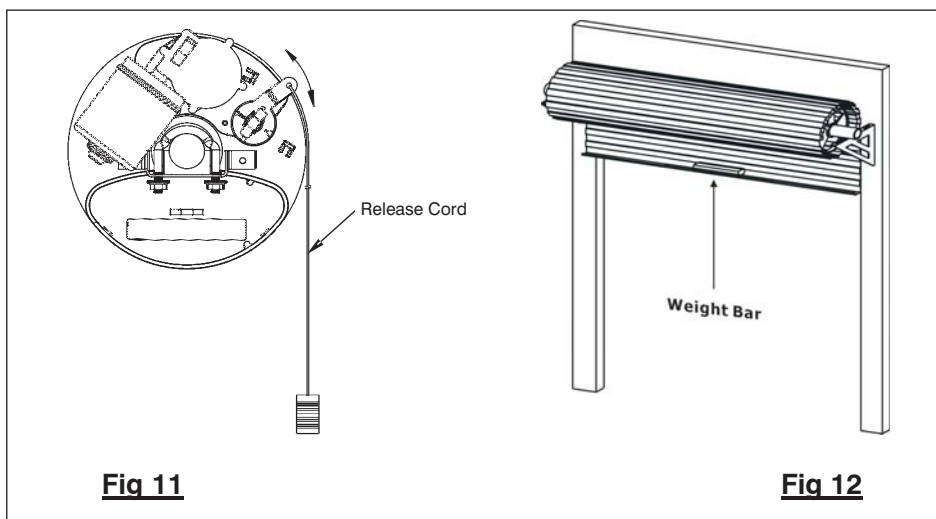

5. Fitting of Weight Bar

- 5.1 Fit the weight bar to the top edge of the garage door bottom rail as depicted in Fig.12

6. Fixing Of Curtain To Drum Wheel

- 6.1 The garage door curtain must be secured to the drum wheel with suitable fasteners such as self drilling

INSTALLATION INSTRUCTIONS

- 6.2 With the garage door in the fully closed position, mark the curtain at points "A" and "B" as depicted in Fig.13
- 6.3 Once marked, open the door slightly so as to have access to the marked positions. Secure the curtain to the drum wheel ensuring that the fixing points are at least 90 degrees apart.

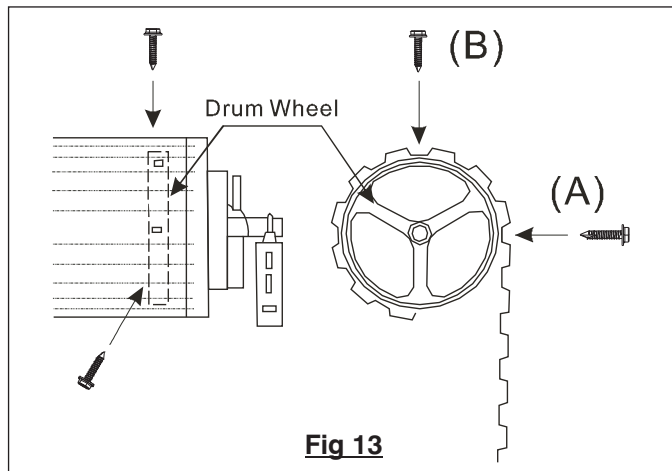

SETTINGS AND ADJUSTMENTS

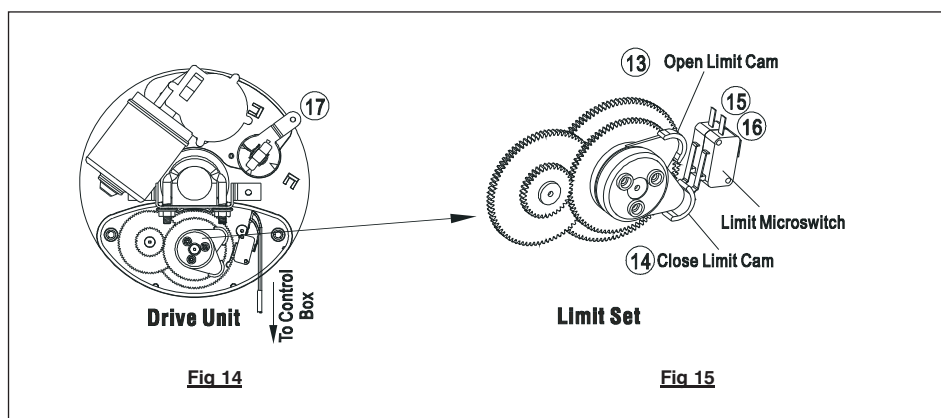

7. Door Travel Adjustment – Open Direction

- 7.1 With the Drive Unit in disengaged mode move the door up by hand to the fully open position.
- 7.2 Remove the limit cover to expose the Limit Adjust Cams. (Fig.14)
- 7.3 Slightly loosen the 3 cam locking screws (to the extent that you can rotate the cam by hand with a firm push).
- 7.4 Rotate the Open Limit (Lower) Cam (Item 13 Fig.15) by hand, in the direction of the Open Limit (Lower) Switch, until you hear the Switch "click". Once the Open Limit Switch "clicks" continue to rotate the cam a further 10 degrees or so towards the switch.
- 7.5 To check the Open Limit Switch adjustment - move the door down by hand and then slowly back up again. The limit switch should "click" approx 100mm BEFORE the door stops make contact with the rail stops.
- 7.6 If not, then adjust the Open Limit Cam accordingly.

8. Door Travel Adjustment – Close Direction

- 8.1 With the Drive Unit in disengaged mode move the door down by hand to the fully closed position.
- 8.2 Move the door down by hand to the desired fully closed position.

SETTINGS AND ADJUSTMENTS

- 8.3 Rotate the Close Limit (Upper) Cam (Item 14, Fig 15) by hand, in the direction of the Close Limit (Upper) Switch, until you hear the Switch “click”. Once the Open Limit Switch “clicks” continue to rotate the Cam a further 10 degrees or so towards the switch.
- 8.4 To check the Close Limit Switch adjustment, raise the door by hand and then slowly lower again. The Close Limit Switch should “click” approx 100mm BEFORE the door touches the ground. If not then adjust the Close Limit Cam accordingly.

9. Connecting to Power Supply

- 9.1 Connect the RDO Battery Charger to a properly earthed power supply.
- 9.2 Switch the power on at the power supply – the LED on the charger should glow red.
- 9.3 **Important Note: Do not mount the charger any further away from the control box than the connection cable allows.**

10. Door Travel - Final Adjustment

- 10.1 Open the garage door to a midway position and then pull once on the red disengage cord to engage the RDO to the garage door.
- 10.2 Test the garage door open and close positions by pressing the red “operate” push button located on the front face of the Control Box.
- 10.3 Check that the garage door opens and closes to the required positions. If not then re-adjust the Open and/or Close Limit Cams accordingly.
- 10.4 Turn the appropriate cam TOWARDS the Limit Switch to DECREASE garage door travel and AWAY from the appropriate Limit Switch to INCREASE garage door travel.
- 10.5 Once finally adjusted, firmly tighten the 3 Limit Cam Locking Screws and refit the Limit Cover Plate.

11. Safety Obstruction Force Adjustment – Close Direction

- 11.1 Locate the Close force setting (DN) thumb screw and turn it to the maximum setting in a clockwise direction. (Lower of 2 screws – refer figure below)

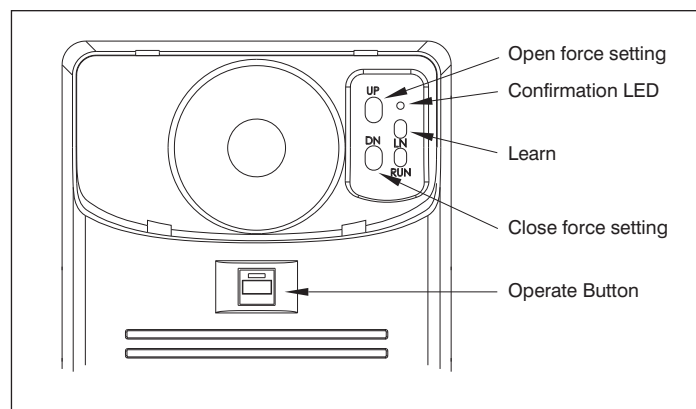

- 11.2 With the garage door in the fully OPEN position - press the red button located on the face of the Control Box. As the garage door commences to CLOSE, slowly begin to turn the Close force setting (DN) thumb screw in an anti-clockwise direction until the garage door stops and reverses towards the Open direction. Now turn the adjustment back 10 degrees in a CLOCKWISE direction.
- 11.3 **Important Note: The garage door must stop and reverse before it reaches the ground.**
- 11.4 Test the adjustment by pressing the red “operate” button again. This time the garage door should reach the fully closed position without reversing.

SETTINGS AND ADJUSTMENTS

12. Safety Obstruction Force Adjustment – Open Direction

- 12.1 Locate the Open force setting (UP) thumb screw and turn it to the maximum setting in a clockwise direction. (Upper of 2 screws – refer figure below)
- 12.2 With the garage door in the fully CLOSED position - press the red button located on the face of the Control Box. As the garage door commences to OPEN, slowly begin to turn the Open force setting (UP) thumb screw in an anti-clockwise direction until the garage door stops. Now turn the adjustment back 10 degrees in a CLOCKWISE direction.

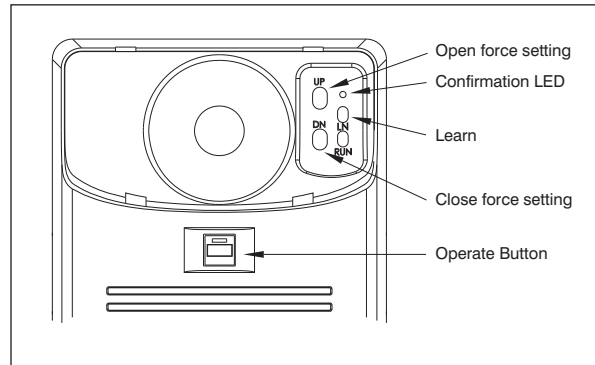

12.3 **Important Note: The door must stop and reverse before it reaches the fully Open position.**

- 12.4 Test the adjustment by pressing the red “operate” button again. This time the door should reach the fully OPEN position without stopping.

13. Safety Obstruction Force Testing – Close Direction

- 13.1 With the garage door in the fully open position, place a length of timber measuring 100mm x 50mm on the floor directly under the middle of the garage door. (Fig.16)
- 13.2 With the garage door in the fully open position - close the door by pressing the red “operate” button located on the front of the Control Box. The garage door should strike the timber and then automatically start to re-open.
- 13.3 If the garage door does not re-open or requires excessive force to re-open, then the Close force setting (DN) thumb will need to be re-adjusted.
- 13.4 Turn the Close direction Close force setting (DN) thumb screw 5 to 10 degrees in an anti-clockwise direction and then repeat steps 13.2 and 13.3 until such time as the garage door will reverse when it hits the timber.

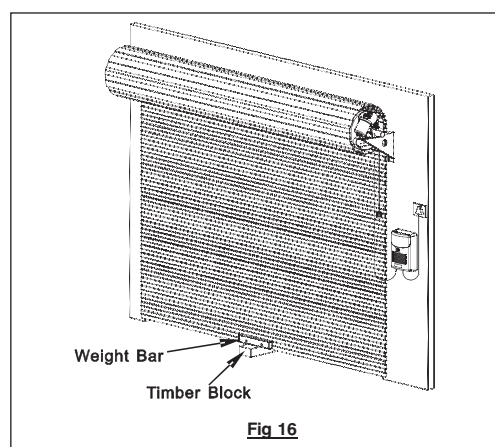

14. Safety Obstruction Force Testing – Open Direction

- 14.1 With the garage door in the fully closed position – press the red “operate” button located on the front face of the Control Box to open the door.

SETTINGS AND ADJUSTMENTS

- 14.2 As the garage door is opening push down firmly on the bottom rail of the door (middle of the door from the inside)

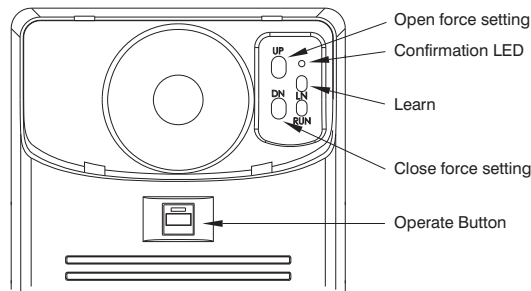

15. Transmitters Code Learning

Note: If the RDO kit has been supplied with a separate NOVA VOYAGER receiver module, please follow the instructions provided with this receiver for learning the transmitters, otherwise proceed as follows:

- 15.1 Remove the hand held transmitter from the packing box.
- 15.2 Remove the light cover from the Control Box by gently pulling at the top edge.
- 15.3 Locate the “Learn” button within the recessed panel at the top right corner of the Control Box
- 15.4 Momentarily press the “Learn” button - red coding indicator lamp will glow solid.
- 15.5 Momentarily press the hand transmitter button - red coding indicator lamp will extinguish.
- 15.6 Momentarily press the hand transmitter button once again - red coding indicator lamp will begin to flash – once flashing stops, the coding sequence has been completed.
- 15.7 Test for correct programming by pressing and holding the hand transmitter button until the door starts to move.
- 15.8 To code another transmitter follow steps 15.3 to 15.7
- 15.9 Replace the Control Box lamp cover once coding has been completed and the RDO is now ready for use.

16. Transmitter Code Erasing

Note: If the RDO kit has been supplied with a separate NOVA VOYAGER receiver module, please follow the instructions provided with this receiver for erasing transmitters, otherwise proceed as follows:

- 16.1 Switch the RDO off at the power supply.
- 16.2 Press and hold down the “Code Set” Button.
- 16.3 While continuing to hold down the “Code Set” button switch the power on at the power supply.
- 16.4 After a few seconds the “Red Coloured LED” will begin to flash.
- 16.5 Once the “Red Coloured LED” stops flashing, release the “Code Set” button and all of the previously stored codes will have been deleted.

17. Wall Switch – Installation

- 17.1 Where provided, a hard wired Wall Switch can be connected to the RDO.
- 17.2 Using 2 core cable (0.5 mm²), strip back both ends of the cable and connect 2 strands of one end to terminals 9A & 9B located on the logic board. (Refer to figure below)

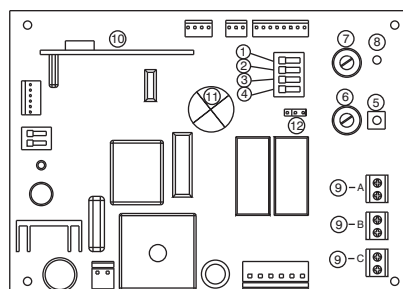

SETTINGS AND ADJUSTMENTS

- 17.3 Connect the 2 strands on the opposite end of the cable to the terminals located on the back of the Wall Switch.
- 17.4 **Important Note: The Wall Switch must be mounted within sight of the door and a reasonable distance away from moving parts. It should be mounted at least 1500mm above the ground and the Entrapment Warning Label provided must be attached adjacent to and within clear sight of it.**

18. Safety Beams – Installation (Order ref: 1302BEAM01)

- 18.1 Locate the Safety Beam Mounting Brackets provided.
- 18.2 Mark the inside door framing so that the bottom edge of the Mounting Brackets sit 125mm off the floor.
- 18.3 Use the 2 mounting screws provided to fasten each Mounting Bracket to the wall. Do not over tighten the fixing screws as the Mounting Brackets will need to undergo adjustment at a later time.
- 18.4 Use the 2 screws and nuts provided to fasten the Safety Beams to the Mounting Brackets so that the Indicator Lamp on each Safety Beam is facing upwards.
- 18.5 Using the twinflex cable provided, strip back and connect the 2 strands of one end of the cable to each of the 2 terminals located on the outer cover of each Safety Beam.
- 18.6 Securely fix the cable up and along the wall and run one length of each cable over to the Control Box.
- 18.7 Strip back and connect one strand of each cable to the terminals marked 9B & 9C (refer to figure below)

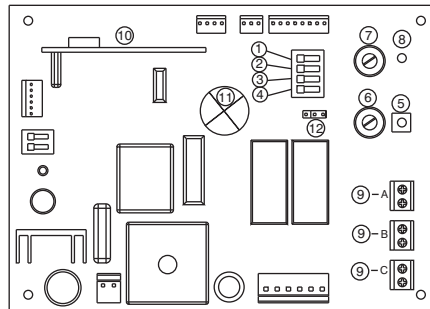

- 18.8 A green pilot light on the “emitter” will illuminate to indicate that the Safety Beams have been connected correctly
- 18.9 Enable Dip Switch No.1 by selecting it to the “on” position
- 18.10 **Important Note: For the Safety Beams to function correctly the jumper plug J8 located on the control board (Item 12) of the RDO must be positioned so that the middle and right hand pins are connected.**
- 18.11 **Important Note: The RDO will only support the fitment of genuine RDO Brand 2 wire Safety Beams. (order ref: 1302BEAM01)**

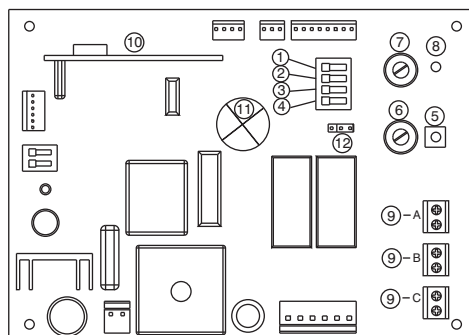

SETTINGS AND ADJUSTMENTS

19. Safety Beams - Alignment

- 19.1 Align the 2 Safety Beams (by turning the mounting bracket) so that their lenses are aimed directly at each other. A red indicator lamp on the “receiver” will glow solid once correct alignment has been achieved.
- 19.2 Test the Safety Beam alignment several times, each time ensuring that when the Safety Beams are obstructed the red indicator lamp is extinguished, and when unobstructed the indicator lamp glows solid.
- 19.3 Firmly tighten the Safety Beam mounting bracket fixing screws.
- 19.4 Installation of Safety Beams is now complete.

20. Safety Beam – Function Testing

- 20.1 Initiate a closing cycle on the RDO and as the Garage Door is closing pass your hand through the line of the Safety Beams. If the Safety Beams are functioning correctly the RDO should stop and then immediately reverse direction.
- 20.2 If the Garage Door commences a close cycle but stops and reverses before the Safety Beams are blocked, check that the Safety Beams are aligned correctly as outlined in points 18.1 ~ 18.3.

21. Auto Close Mode

- 21.1 In Auto Close Mode the RDO will automatically close a pre set time after it reaches the fully open position.
- 21.2 To enable Auto Close Mode move dip switch No.2 to the “ON” position.
- 21.3 The Auto Close pre set time is determined by the position of dip switches Nos. 3 & 4 and is set out in the following table:
- 21.4 **Important Note: Auto Close Mode will only work if Safety Beams have been enabled and correctly aligned**

Time/Dip switch	3	4
15 sec	OFF	OFF
30 sec	ON	ON

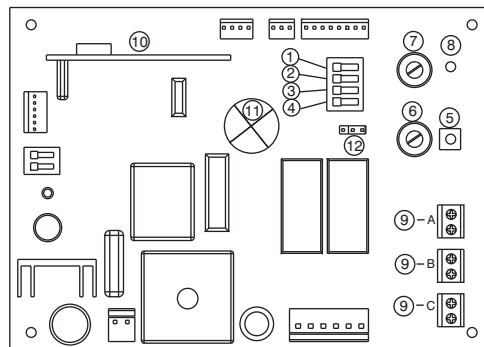

22. Output Terminals

- 22.1 The RDO provides a 24VDC external power supply to support the connection of external accessories.
- 22.2 The values of the output terminals is set out in the following table: 9A ~ Com, 9B ~ Neg, 9C ~ +24VDC (Fig.xxx).
- 22.3 **Important Note:** For connection of any external accessory other than Safety Beams the jumper plug J8 (Item12) located on the control board of the RDO must be positioned so that the middle and left hand pins are connected.

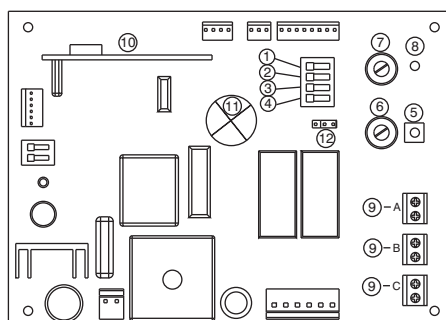

TROUBLE SHOOTING

SYMPTOM	POSSIBLE CAUSES	REMEDY
Door will not operate	Mains power not turned on Door is obstructed	Turn on mains power Remove obstruction
Door is locked or motor jammed	Mechanical door lock has been engaged	Unlock door Inspect door and remove jam
Door will not reverse on hitting an object	Safety Obstruction Force setting is too high and may require adjustment.	Refer to Installation instructions, - Items 8~10
Door moves downwards and reverses itself upwards	Safety Obstruction Force setting is too light and may require adjustment. Adverse weather conditions (wind or cold) causing door to stiffen and become tight. Possible obstruction under door	Refer to Installation Instructions – Items 8 ~ 10
Door operates from drive unit but not from hand transmitter	Transmitter is damaged or broken Transmitter Code has not been programmed into the receiver Receiver antenna wire not straight Battery flat.	Try to operate the door with an alternative transmitter Refer to installation instruction Item 5. Locate and stretch aerial wire to be as straight as possible Replace battery(12V)
Door does not close fully	Limit micro switch incorrectly adjusted	Re-adjust limit switch - Refer Installation Instruction Item 3
Lights malfunction	Globe blown	Replace with 24VDC/3W globe
Door Stops on Upward cycle before reaching the fully open position	Door may be obstructed. Door springs may have lost tension Safety Obstruction Force may need adjustment	Disengage Opener and check door for free movement Call serviceman to affect repairs Refer Section 8~10 of Installation manual.
Auto close not working	P.E. Beam faulty or wiring broken P.E. Beam obstructed Auto close time not set	Repair P.E. or broken wire Remove obstruction from the path of beam. Refer to installation inst. - Items 13 & 14.

TECHNICAL SPECIFICATIONS

CONFIGURATION:	Separate Control Box & Drive Unit
INPUT VOLTAGE:	220V AC +/-10% 50Hz
CHARGER	27.5V, 200mA peak current.
CONTROLLER VOLTAGE:	24V DC
OPENER LIFTING FORCE:	300N
OPENER OPENING/CLOSING LIMITS TRAVEL:	4.5 Turns of Door Drum Wheel
RECEIVER TYPE:	NOVA code rolling
RECEIVER CODE STORAGE CAPACITY:	22 Transmitter Codes
TRANSMITTER FREQUENCY:	433 MHz
TRANSMITTER BATTERY VOLTAGE:	12 Volt
GLOBE:	15W 24 V DC Edison screw Type
SAFETY REVERSING SYSTEM:	Pot Adjustable Current Sensing

CONTROL BOX MOUNTING TEMPLATE

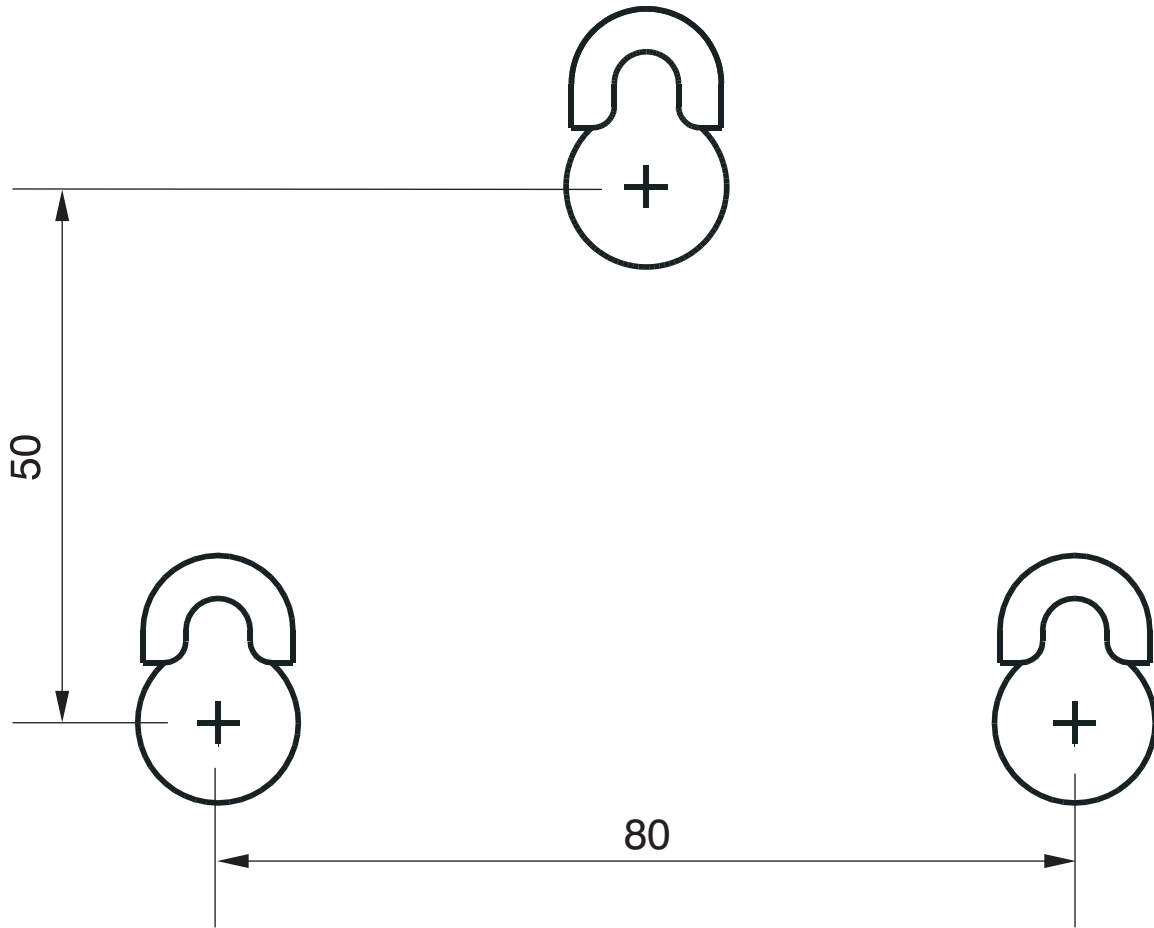



Centurion Systems (Pty) Ltd Head Office:

Tel: +27 (0)11-699-2400, Fax: +27 (0)11-704-3412 or (0)11-462-6669
(Omit (0) when dialing from outside South Africa)

148 Epsom Avenue, North Riding
P.O. Box 506, Cramerview, 2060
South Africa

Sharecall 0860-CENTURION

(Sharecall number applicable when dialed from within South Africa only)

**or visit www.centsys.co.za
for details of your nearest agent**

For technical support, contact:

South African Branches and Regional Distributors:

Johannesburg Central/West Rand	011-699-2400
Johannesburg East-Rand	011-397-6401
Durban	031-701-9583
Nelspruit	013-752-8074/5
Pretoria	012-349-1745
Cape Town	021-552-9425
Bloemfontein	051-430-0870
Port Elizabeth	041-581-6994/5
East London	043-743-4923
Kimberly	053-832-3231
Vereeniging	016-422-5667

Other Countries:

Please refer to our website: www.centsys.co.za

Product Code:1302.D.01.0002



Latest Revision: 19.03.2009
Document Ref.: 1302.D.01.0002
© 2009 Centurion Systems (Pty) Ltd.

