

B680H

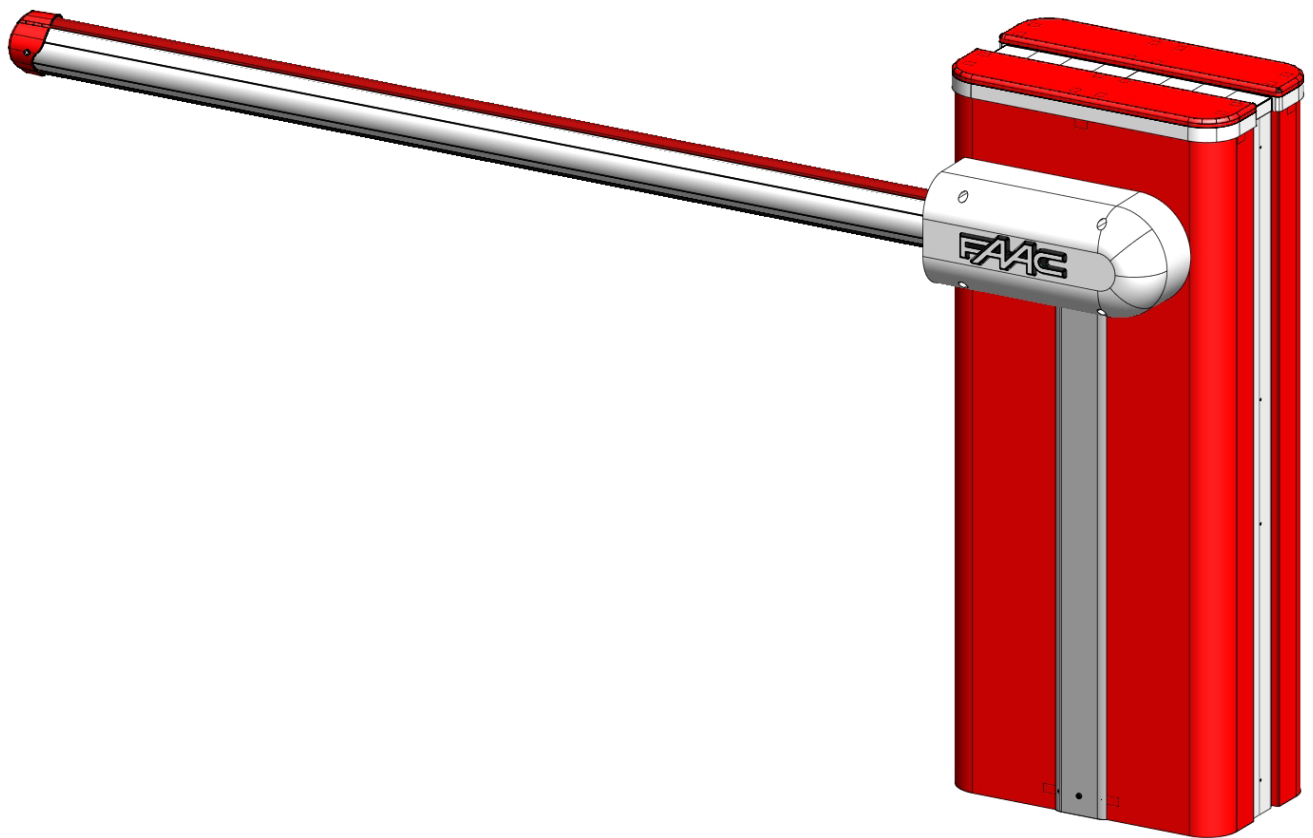

FAAC

Leggere completamente questo manuale di istruzioni prima di iniziare l'installazione del prodotto.



Il simbolo evidenzia le note importanti per la sicurezza delle persone e l'integrità dell'automazione.



Il simbolo richiama l'attenzione sulle note riguardanti le caratteristiche od il funzionamento del prodotto.

Read this instruction manual to the letter before you begin to install the product.



Symbol highlights notes that are important for people's safety and for the good condition of the automated system.



Symbol draws your attention to the notes about the product's characteristics or operation.

Lire ce manuel d'instructions dans son entier avant de commencer l'installation du produit.



Le symbole met en évidence les remarques pour la sécurité des personnes et le parfait état de l'automatisme.



Le symbole attire l'attention sur les remarques concernant les caractéristiques ou le fonctionnement du produit.

Vor der Installation des Produkts sind die Anweisungen vollständig zu lesen.



Mit dem Symbol sind wichtige Anmerkungen für die Sicherheit der Personen und den störungsfreien Betrieb der Automation gekennzeichnet.



Mit dem Symbol wird auf Anmerkungen zu den Eigenschaften oder dem Betrieb des Produkts verwiesen.

Lean completamente este manual de instrucciones antes de empezar la instalación del producto.



El símbolo identifica notas importantes para la seguridad de las personas y para la integridad de la automatización.



El símbolo llama la atención sobre las notas relativas a las características o al funcionamiento del producto.

Lees deze instructiehandleiding helemaal door alvorens het product te installeren.



Het symbool is een aanduiding van opmerkingen die belangrijk zijn voor de veiligheid van personen en voor een goede automatische werking.



Het symbool vestigt de aandacht op opmerkingen over de eigenschappen of de werking van het product.

INDEX

ENGLISH

B680H AUTOMATED SYSTEM

- 1. TECHNICAL SPECIFICATIONS3
 - 1.1 Summary table.....3
 - 1.2 Key Fig. 5.....3
 - 1.3 Key Fig. 6.....3
- 2. ELECTRICAL PREPARATIONS (standard system)3
- 3. BARRIER DIMENSIONS3
- 4. INSTALLING THE AUTOMATED SYSTEM3
 - 4.1 Preliminary checks3
 - 4.2 Walling in the foundation plate3
 - 4.3 Electrical preparations.....3
 - 4.4 Mechanical installation3
 - 4.5 Fixing the plunging pistons.....4
 - 4.6 Balancing the barrier4
- 5. START-UP.....4
 - 5.1 Connecting the control equipment.....4
 - 5.2 Testing the automated system4
- 6. MANUAL OPERATION4
- 7. RESTORING NORMAL OPERATION4
- 8. MAINTENANCE4
 - 8.1 Topping up the oil4
 - 8.2 Air bleeding4
- 9. REVERSING THE OPENING DIRECTION4
- 10. ACCESSORIES5
 - 10.1 Installing a photocell5
 - 10.2 Installing the bar light kit5
 - 10.3 Installation of a receiver antenna.....5
- 11. REPAIRS.....5

E680 CONTROL BOARD

- 1. WARNINGS6
- 2. DESCRIPTION OF THE COMPONENTS6
- 3. TECHNICAL SPECIFICATIONS6
- 4. ELECTRICAL CONNECTIONS.....7
 - 4.1 Terminal board J1 (inputs)7
 - 4.2 Terminal board J2 (outputs).....8
 - 4.3 Terminal board J3 (external flashing lamp)8
 - 4.4 Terminal board J4 (loop detector)8
 - 4.5 Connector J5 (Motor).....8
 - 4.6 Connector J7 (Encoder)8
 - 4.7 Connector J10 (Radio).....8
 - 4.8 Connector J11 (Beam break-out sensor)8
 - 4.9 Connector J12 (Emergency battery).....8
 - 4.10 Connector J13 (36VDC Power Supply)8
 - 4.11 Connector J15 (flashing traffic light)8
- 5. PROGRAMMING8
 - 5.1 Basic configuration.....9
 - 5.2 Changing the predefined parameters set10
 - 5.3 BUS accessories menu11
- 6. Advanced Configuration12
 - 6.1 Configuring the loop detector13
 - 6.2 Expert Configuration14
 - 6.3 Pre-Defined Parameter Sets17
 - 6.4 "Expert" default parameters18
- 7. START-UP.....18
 - 7.1 Verifying the diagnostic LEDs18
 - 7.2 Setup.....18
- 8. TESTING THE AUTOMATED SYSTEM18
- 9. MASTER/SLAVE CONFIGURATION19
- 10. INTERLOCK CONNECTION19
- 11. OPERATING LOGICS TABLE20
- 12. BALANCING TABLES23
- 13. DEFAULT SELECTION TABLES24

CE DECLARATION OF CONFORMITY FOR MACHINES (DIRECTIVE 2006/42/EC)

Manufacturer: FAAC S.p.A.
Address: Via Calari 10 - 40069 Zola Predosa BOLOGNA - ITALY
Declares that: The operator mod. B680H with control board E680

• is built to be integrated into a machine or to be assembled with other machinery to create a machine under the provisions of Directive 2006/42/EC;

• conforms to the essential safety requirements of the following EEC directives:

2006/95/EC Low Voltage Directive
 2004/108/EC Electromagnetic Compatibility Directive

and also declares that it is prohibited to put into service the machinery until the machine in which it will be integrated or of which it will become a component has been identified and declared as conforming to the conditions of Directive Directive 2006/42/EC.

Bologna, 1 October 2011

The Managing Director
 A. Marcellan

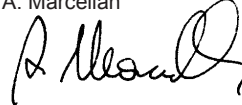

WARNINGS FOR THE INSTALLER

GENERAL SAFETY OBLIGATIONS

- 1) **ATTENTION! To ensure the safety of people, it is important that you read all the following instructions. Incorrect installation or incorrect use of the product could cause serious harm to people.**
- 2) Carefully read the instructions before beginning to install the product..
- 3) Do not leave packing materials (plastic, polystyrene, etc.) within reach of children as such materials are potential sources of danger.
- 4) Store these instructions for future reference.
- 5) This product was designed and built strictly for the use indicated in this documentation. Any other use, not expressly indicated here, could compromise the good condition/operation of the product and/or be a source of danger.
- 6) FAAC declines all liability caused by improper use or use other than that for which the automated system was intended.
- 7) Do not install the equipment in an explosive atmosphere: the presence of inflammable gas or fumes is a serious danger to safety.
- 8) The mechanical parts must conform to the provisions of Standards EN 12604 and EN 12605. For non-EU countries, to obtain an adequate level of safety, the Standards mentioned above must be observed, in addition to national legal regulations..
- 9) FAAC is not responsible for failure to observe Good Technique in the construction of the closing elements to be motorised, or for any deformation that may occur during use.
- 10) The installation must conform to Standards EN 12453 and EN 12445. For non-EU countries, to obtain an adequate level of safety, the Standards mentioned above must be observed, in addition to national legal regulations..
- 11) Before attempting any work on the system, cut out electrical power.
- 12) The mains power supply of the automated system must be fitted with an all-pole switch with contact opening distance of 3mm or greater. Use of a 6A thermal breaker with all-pole circuit break is recommended.
- 13) Make sure that a differential switch with threshold of 0.03 A is fitted upstream of the system.
- 14) Make sure that the earthing system is perfectly constructed, and connect metal parts of the closing elements to it.
- 15) The automated system features a built-in anti-crushing safety device consisting of a torque control. It is however necessary to check its tripping threshold, as provided for in the Standards described in point 10.
- 16) The safety devices (EN 12978 standard) protect any danger areas against mechanical movement Risks, such as crushing, dragging, and shearing.
- 17) For each system, we recommend using at least one signal light (e.g.: FAACLED or integrated flashing traffic light) as well as a warning sign securely fixed to the structure, together with the devices described in point "16".
- 18) FAAC declines all liability as concerns safety and efficient operation of the automated system, if system components not produced by FAAC are used.
- 19) For maintenance, strictly use original parts by FAAC.
- 20) Do not in any way modify the components of the automated system
- 21) The installer shall supply all information concerning manual operation of the system in case of an emergency, and shall hand over to the User the leaflet supplied with the product.
- 22) Do not allow children or adults to stay near the product while it is operating.
- 23) Keep radio controls or other pulse generators away from children, to prevent the automated system from being activated involuntarily.
- 24) Transiting is permitted only when the automated system is stationary.
- 25) The User must not attempt any kind of repair or direct action whatever and contact qualified personnel only.
- 26) Maintenance: check at least every 6 months the efficiency of the system, particularly the efficiency of the safety devices (including, where foreseen, the operator thrust force) and of the release devices.
- 27) **Anything not expressly specified in these instructions is not permitted.**

B680H AUTOMATED SYSTEM

The automated system consists of a white aluminium beam with reflectors, optional signalling lights, a covering compartment and steel upright profile. Inside the compartment there is an operator consisting of the upright profile with a hydraulic unit and two plunging pistons fixed to it, which, by means of a rocker arm, rotate the beam. The latter remains balanced thanks to a balance spring fitted on one of the two plunging pistons. The electronic control equipment is also housed on the upright, inside a compartment, and the whole is protected by the external covering compartment.

The system features an adjustable electronic anti-crushing safety, a device that guarantees stopping and locking of the beam in any position, and a convenient manual release for use in case of black-out or inefficiency.

1. TECHNICAL SPECIFICATIONS

1.1 Summary table

Power supply (V ~ / Hz)	90-240 V ~ / 50-60Hz 
Electric Motor	36Vdc Brushless
Absorbed power (W)	240
Absorbed current (A)	1,1A at 230 V ~
Motor rotation speed (RPM)	1000-6000
Pump capacity	3,2 l/min (max)
Yielded torque (Nm)	0-370
Oil type	FAAC HP OIL
Oil quantity (L)	~ 1,2
Anti-crushing System	Electronic with absolute encoder
Deceleration type	Electronic with absolute encoder
Operating ambient temperature (°C)	-20 / +55
Rated Operating Time (ROT)	Continuous Duty at +55°C
Compartment protection treatment	EP SL LF PRIMER
Beam type	Rounded with lights and rubber bumper
Protection Class	IP44
Compartment Dimensions (LxHxP) (mm)	See illustration Fig. 8
Weight (body + compartment) (kg)	65 + 20 / 85 (total)
Opening and closing time (s), including deceleration	1.5 - 2 m beam 6 opening / 9 closing - 8 m beam

1.2 Key Fig. 5

- | | |
|--------------------------------|----------------------------------------|
| ① Built-in flashing lamp | ⑨ Left feed tube |
| ② Electronic control equipment | ⑩ Release lock |
| ③ Oil filling cap | ⑪ Left plunging piston |
| ④ Right piston bleeder screw | ⑫ Left piston bleeder screw |
| ⑤ Hydraulic unit | ⑬ Covering compartment |
| ⑥ Right plunging piston | ⑭ Encoder |
| ⑦ Unit cooling fan | ⑮ Box connecting the main power supply |
| ⑧ Right feed tube | ⑯ Switching power supply |

1.3 Key Fig. 6

- | | |
|---------------------|-------------------------------|
| ① Bearing structure | ⑤ Securing plate |
| ② Mechanical stops | ⑥ Spring guide |
| ③ Rocker arm | ⑦ Balance spring |
| ④ Drive shaft | ⑧ Preload adjustment ring nut |

2. ELECTRICAL PREPARATIONS (standard system)

See details in the illustration Fig. 7.

3. BARRIER DIMENSIONS



All the dimensions contained in this manual are expressed in mm

For barrier dimensions, refer to Fig. 8. The covering compartment is the same for both models, while the bar dimensions differ as shown in detail at ① (bar S) and ② (bar L) - Fig. 8

4. INSTALLING THE AUTOMATED SYSTEM

4.1 Preliminary checks

For the safety and correct operation of the automated system, ensure that the following conditions are met:

- When in motion, the beam must not encounter obstacles or flying power cables.
- The characteristics of the ground must guarantee sufficient solidity of the foundation plinth.
- No tubes or electrical cables should be present in the plinth digging area.
- If the barrier body is exposed to vehicle transit, provide for adequate protection against accidental impact, when possible.
- Ensure that there is an efficient earth plate for connecting the upright profile.



Wall in the foundation plate so as to allow easy access to the barrier door. The foundation plinth must be installed keeping in mind the characteristics of the ground to ensure perfect stability of the automated system.

4.2 Walling in the foundation plate

- Assemble the foundation plate as shown in Fig. 9 ref. ①
- Set the foundation plinth as shown in Fig. 9 ref. ②
- Wall in the foundation plate as shown in Fig. 9 ref. ② providing for one or more sheaths for the passage of the electrical cables.



For dimensional reasons, the cable passage sheaths must be placed on one side of the space provided at the base of the barrier (see Fig. 9).

- Use a level to ensure that the plate is perfectly horizontal. Wait for the cement to set.

4.3 Electrical preparations

Following the instructions shown in Fig. 7, prepare the ducts to make all the control board electrical connections with the chosen accessories.

Always separate the power cables from the control and safety cables (button, receiver, photocells, etc.).

Use the cable diameters shown in Fig. 7 and referred to in the following key:

- | | |
|----------------------|------------------|
| ① Barrier mod. B680H | ④ Flashing lamp |
| ② Photocells | ⑤ Radio receiver |
| ③ Key button | ⑥ Magnetic Loops |

4.4 Mechanical installation

- Fix the upright profile onto the foundation plate using the four provided nuts (Fig. 11). Remember that the hydraulic unit must usually face the inside of the property.
- Prepare the operator for manual operation, as shown in paragraph 6 / Fig. 18 (Manual Operation).
- Remove and set aside the venting screw, as shown in Fig. 12 ref. ②.
- Set the rocker arm horizontally, then remove, as shown in Fig. 13 ref. ①, the upper fixing pin of the piston on the bar side and insert on it the spring guide and balance spring, as shown in Fig. 14, followed by the preload adjustment ring nut, paying attention to the direction it must be inserted in (see Fig. 14 ref. ①).

- Secure the piston without spring in the same hole shown above.



With the barrier open, the spring must NOT be compressed.

- Install the beam and its fixing pocket using the provided screws, as shown in Fig. 17, ref. from ① to ⑧ (the rubber profile of the beam must face the closing direction)



Do not grease the fixing screw of the bar.

- If the application requires a segmented bar, once the first segment and fixing pocket have been assembled, close the automatic system, lock it and follow the instructions for additional segment assembly, as shown in Fig. 20, ref. from ① to ④
- Adjust the opening and closing mechanical stops as shown in Fig. 15, and tighten the lock nut.
- Ensure that the beam is balanced following the instructions contained in paragraphs 4.5 and 4.6.



The compartment should be fixed, as shown in the sequence in Fig. 21, when all mechanical installations, wiring and start-up have been completed.

4.5 Fixing the plunging pistons

Barrier balancing is obtained by correctly adjusting the spring preload ring nut (see next paragraph) but also by setting the two plunging pistons in the most suitable position. This position is determined by the length of the beam and the presence of any accessories that may be applied to it (see paragraph 11).

4.6 Balancing the barrier

WARNING: This procedure must be carried out as the barrier is not internally balanced. The beam is balanced when, operating manually (ref. paragraph 6) the beam remains stationary in the 45° position.

To balance the barrier, proceed as follows:

- Install the bar and all related accessories on the barrier structure, as required by the final configuration of the system.
- Ensure that the operator is released: see paragraph 6.
- Ensure that the plunging pistons are secured on the rocker arm according to the instructions in paragraph 11 in Table 2 or Table 3, depending on the installed beam model (S or L, respectively)
- Manually move the bar to the 45° position and verify it remains stationary. If the bar tends to open, turn the spring preload ring nut anti-clockwise (Fig. 16 ref. ①); if it tends to close, turn the ring nut clockwise (Fig. 16 ref. ②).

5. START-UP

5.1 Connecting the control equipment

WARNING: Before carrying out any work on the control board (connections, maintenance, etc.) always cut off the electrical power.



For all automatic system connections and testing, refer to the section dedicated to the electronic equipment, paragraph 1 on page 6 and following.

5.2 Testing the automated system

Once installation has been completed, apply the "danger" sign sticker (ref. Fig. 29) to the top of the upright profile. Proceed to ensure correct operation of the automated system and all the accessories connected to it.



Give the Customer the "User's Manual", the documentation required by current law and show how to correctly operate the barrier, pointing out the areas of potential danger.

6. MANUAL OPERATION

Should manual operation of the barrier be required due to electrical power cut-offs or automated system inefficiency, use the release device with the provided key.

The provided unlocking key is either triangular (Fig. 18 ref. ①) or customised (Fig. 18 ref. ②) optional).

- Insert the unlocking key in the lock and turn the key **anticlockwise** until it clicks into place, as shown in Fig. 18
- Open or close the beam manually.



With the bar released, the motor may start for approximately 3 seconds. This is normal and determined by the parameter Hold Close / Hold Open

7. RESTORING NORMAL OPERATION

To avoid an accidental pulse opening the barrier during this operation, before activating the locking system, cut off all power to the system.

triangular unlocking key (standard):

- turn the key **clockwise** until it stops and then remove it (Fig. 18 ref. ①).

customised unlocking key (optional):

- turn the key **clockwise** until it stops and then remove it (Fig. 18 ref. ②).

8. MAINTENANCE

When performing six-month maintenance, always check the correct balancing of the system and the correct operation of the safety devices.

8.1 Topping up the oil

Check the amount of oil in the tank every 6 months.

The level must be included between the two notches on the inspection rod.

To top up, unscrew the filler cap (Fig. 12 ref. ①) and pour oil up to the indicated level.

Use only FAAC HP OIL.

8.2 Air bleeding

FAAC products are delivered already bled of any air in the hydraulic circuit. Maintenance operations, replacing spare parts (e.g. connection pipes) or careless transport can cause entry of air in the hydraulic circuit, which in turn can cause operator irregular movement or reduce its torque. Should beam movement be irregular, release the air from the hydraulic system following the instructions below:

- Electrically operate the beam:
- When opening is completed, slightly loosen and tighten the bleeder screw of the piston with the balance spring (Fig. 5 ref. ④).
- When closing is completed, slightly loosen and tighten the bleeder screw of the piston without the balance spring (Fig. 5 ref. ②).

If necessary, repeat the operation until regular movement of the beam is obtained.



Care needs to be taken at this stage as the pistons contain oil under pressure which could leak out if the screws are loosened too much.



If the parameters **FO and **FC** in Advanced Configuration have been changed and set to a value lower than default, during bleeding we recommend setting them to an equal or greater value, to facilitate air bleeding**

9. REVERSING THE OPENING DIRECTION

The opening direction of the barrier is usually determined at the time of installation with the installation of the spring guide, the spring and the preload adjustment ring nut on the piston located on the beam downward travel side.

Should it be necessary to change the opening direction, proceed as follows:

- Release the operator, as shown in paragraph 6, and place the beam in vertical position, then lock the operator again.
- Remove the beam as shown in Fig. 17.
- Remove the device securing the plunging piston to the rocker arm, as shown in Fig. 13.
- Loosen the pre-load ring nut completely, remove it and then remove the balancing spring and spring guide, reversing the order described in paragraph 4.4 and in Fig. 14 regarding the mechanical installation of the automated system.
- Refit the plunging piston in the correct fixing hole.
- Proceed to remove the fixing screw on the piston on the opposite side.
- Release the automated system, turn the rocker arm 90° and re-insert, in order, the spring guide, the balancing spring and the ring nut in the plunging piston installed on the new closing side, according to the order described in Fig. 14. Once this is done, refit the plunging piston on the rocker arm.
- Reinstall the bar following the instructions in Fig. 17.
- Balance the system once again following the procedure described in paragraphs 4.5 and 4.6.
- Lock the operator once again following the instructions in paragraph 7
- **Reverse the motor cable connection as shown in point ④ of Fig. 14**

10. ACCESSORIES

10.1 Installing a photocell

The barrier is equipped with a lateral covering profile (fitted in the compartment opening) under which there are holes for containing Safebeam, BUS or wireless photocells.

To install the photocells, proceed as follows:

1. Remove the barrier compartment.
2. Match the holes on the barrier covering profile on the photocell installation side; ref. ① is used to fix the device, ref. ② is used for the passage of the its power cable. Determine the hole size according to the size of the cables and of the fixing screws used.
3. Connect the photocell following the provided diagram.
4. Fix the photocell to the lateral profile, as shown in Fig. 22.

10.2 Installing the bar light kit

Installation of an LED bar light kit increases visibility of the bar. Proceed to install following the instructions contained in Fig. 31 and securing the connection cable according to the path shown, using the openings for inserting the tie straps, located on the upright. Connect the kit to output Out 4 on the electronic board and configure it according to the available switching on modes (refer to the section regarding the electronic board, paragraph 6 on page 12).



Ensure that the two connector jacks are actually in contact with the conductors inside the cord. Should the bar lights still not turn on, reverse the connection polarity.

10.3 Installation of a receiver antenna

In case a receiver antenna should need to be attached to the barrier, it can be secured to the flashing integrated traffic light connector (or to the plastic bracket, if the optional flashing traffic light connector should not have been installed), as indicated in the diagrams in Fig. 32.

11. REPAIRS

For repairs, contact an authorised FAAC Service Centre.

E680 CONTROL BOARD

1. WARNINGS

Warning - Before carrying out any work on the control board (connections, maintenance, etc.) always:

- cut off the electrical power;
- install a differential magnetothermic switch with a suitable activation threshold upstream from the system;
- always separate the power cables from the control and safety cables (button, receiver, photocells, etc.);
- avoid any electrical disturbance using separate sheaths or a shielded cable (with the shield connected to the earth).

2. DESCRIPTION OF THE COMPONENTS

DISP1	Signalling/Programming display
DL1	BUS Device status
DL2	BUS status (see paragraph 5.3)
DL3	LOOP 1 status
DL4	LOOP 2 status
DL5	Board failure signal
DL6	Not used
DL7	Encoder status
DL8	Not used
DL9	Board power supply present
DL10..DL14	Inputs status LEDs (see paragraph 4.1)
DL15	Released bar signal
DL16	Battery power signal
DL17	Radio channel 1 activity
DL18	Radio channel 2 activity
J1	Input signal connector
J2	Digital output connector
J3	Signalling lamp connector
J4	Detection loop connector
J5	Motor connector
J6	BUS 2Easy connector
J7	Beam movement encoder connector
J10	Decoder / Minidec / RP-RP2 radio board connector
J11	Released bar detection connector
J12	Emergency battery connector
J13	Continuous power voltage connector
J14	USB connector for firmware upgrade
J15	Integrated flashing traffic light connector
F	Programming key "F"
+	Programming key "+"
-	Programming key "-"
SW4	Programming key "SETUP"
M1/M1A/M2	Optional module connector (Connectivity):

Fig. 1

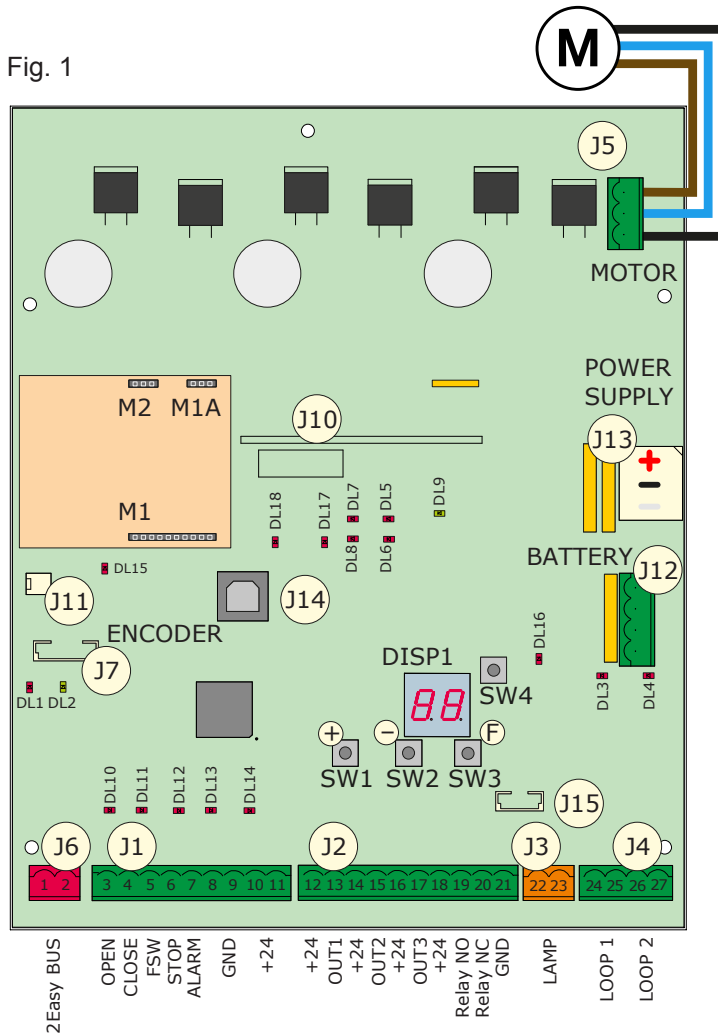

3. TECHNICAL SPECIFICATIONS

Mains power voltage	90-240 V~ +6% -10% connected to switching power supply
Continuous power voltage	36 V ===
Absorbed power	270W
Accessories power supply	24 V ===
Max accessories current	800 mA
Operating ambient temperature	from -20°C to +55°C
Protection fuses	4 self-restoring

Pause time	Programmable (from 0 seconds to 4.1 minutes)
Work time	Programmable (from 0 to 4 minutes)
Motor power	Programmable on 50 levels
Motor speed	Programmable on 10 levels
Programmability	3 configuration levels for greater flexibility of use
Rapid connector	1 5-pin connector for Minidec radio board, Decoder, RP/RP2
Programmable outputs	4 programmable outputs in 19 different functions
Specifications	Deceleration management, encoder, multi-function display, BUS technology and BUILT-IN METAL MASS DETECTOR, USB connector for firmware upgrade

4. ELECTRICAL CONNECTIONS

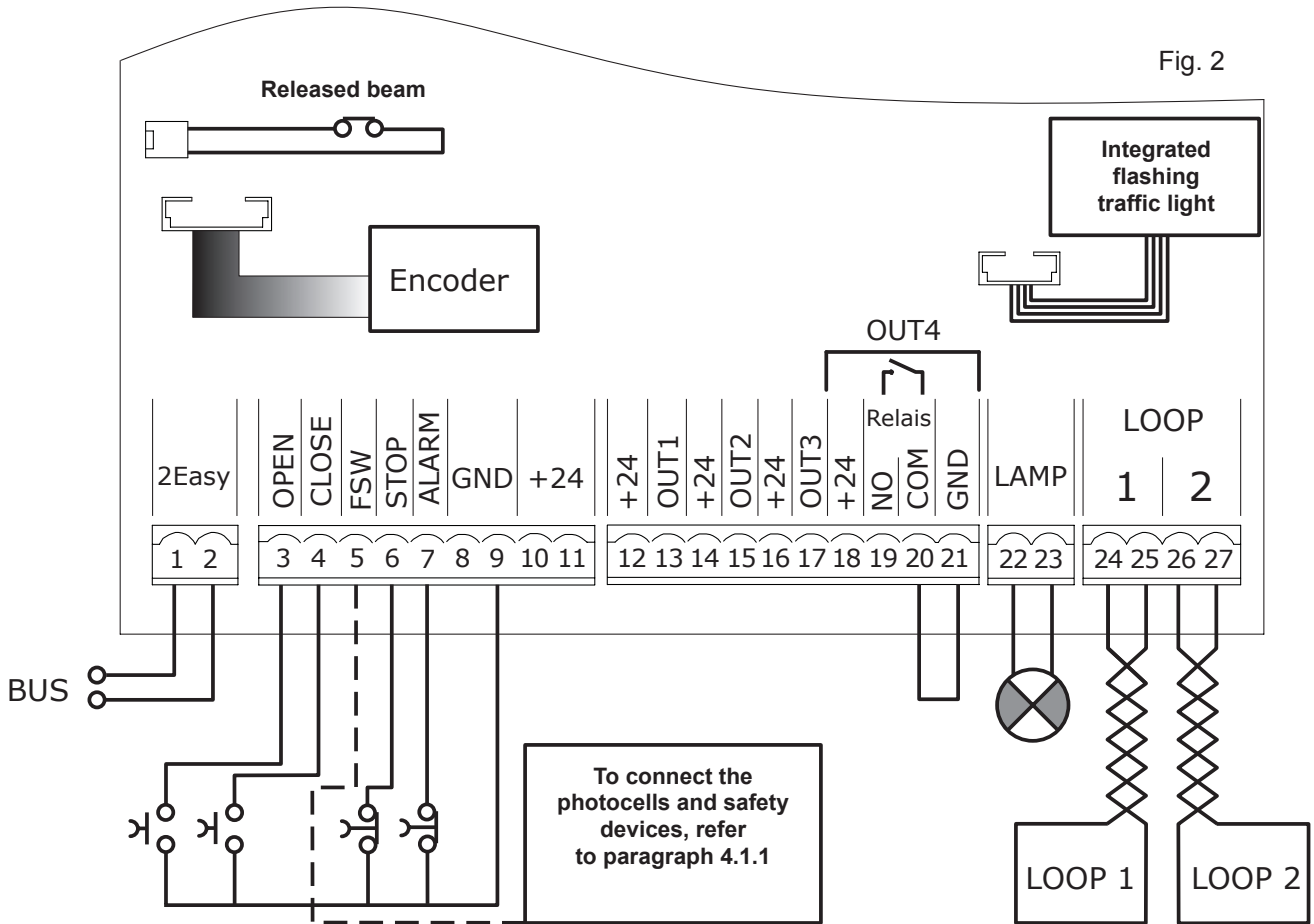

Fig. 2

ENGLISH

4.1 Terminal board J1 (inputs)

OPEN - Open” command (N.O. - terminal 3): means any pulse generator (e.g. button) which, by closing a contact, commands opening and/or closing of the barrier.

CLOSE - Close” command (N.O. - terminal 4): means any pulse generator (e.g. button) which, by closing a contact, commands closing of the barrier.

FSW - Safety contact when closing (N.C. - terminal 5): the purpose of the closing safeties is to protect the area affected by the movement of the barrier during the closing phase, reversing its motion. *They never trip during the opening cycle.*

The closing Safeties, if engaged when the automated system is open, prevent the closing movement.



If CLOSE safety devices are not connected, jumper terminals FSW and GND (Fig. 26) and leave the FAILSAFE function (parameter \square | in Advanced Configuration) set on the default value (disabled)

STP - STOP contact (N.C. - terminal 6): means any device (e.g. button) which, by opening a contact, can stop movement of the automated system.



If STOP safety devices are not connected, jumper terminals STOP and GND (Fig. 26)

ALM - Emergency contact (N.C. - terminal 7): means any device (e.g. switch) which, if activated in a situation of emergency, will open the barrier until the contact is restored. When activated, this input has priority over any other command.



If emergency safety devices are not connected, jumper terminals ALM and GND (Fig. 26)

GND (terminals 8-9) - Accessories power supply minus
+24 (terminals 10-11) - Accessories power supply plus



The maximum load of the accessories is 800mA. To calculate absorption, refer to the instructions included with the individual accessories.

4.1.1 Connecting the safety devices

The E680 control board features an input for **closing safety devices**, which trip during closing of the automated system, provided to protect the gate area from the risk of impact.

These devices must use a signal with “N.C.” contact, and must be connected in series to the relay photocells that may be installed on the system, as shown in Fig. 23 to Fig. 26.

Fig. 23: connection of one pair of closing photocells, with **FAILSAFE safety enabled**: in addition to making the connection as shown in the diagram, it is necessary to set in Advanced Configuration \square | = \square |

Fig. 24: connection of one pair of closing photocells without FAILSAFE safety

Fig. 25: connection of two pairs of closing photocells without FAILSAFE safety

Fig. 26: connection of no relay safety device

4.1.2 Connecting BUS photocells

Up to 8 pairs of photocells can be connected to the E680 control board using BUS technology. The connection must be made in parallel, on terminal board J6, using a single power/communication line, as shown in Fig. 27.

 **BUS photocells do not require a matching polarity connection.**

The 8 pairs of photocells feature the following functions:
 Pairs of closing photocells: max 7
 Pairs of OPEN pulse photocells: max 1

After positioning the BUS technology photocells, it is necessary to proceed with selecting the address for each pair using various combinations of the DIP-SWITCHES located on each photocell.

 **Set the SAME DIP-SWITCH ADDRESS chosen both on the transmitter and receiver of the same pair.**

 **Ensure that two or more pairs of photocells do not have the same address. If no BUS accessories are used, leave terminals 1 and 2 free.**

The following table describes how to set the dip-switches located inside the transmitter and receiver of the BUS photocells.

Addressing BUS photocell PAIRS

DIP-SWITCH TX				← SAME ADDRESS →		DIP-SWITCH RX			
Dip 1	Dip 2	Dip 3	Dip 4	Pair no.	Type				
ON	OFF	OFF	OFF	1° Pair	CLOSE photocells				
ON	OFF	OFF	ON	2° Pair					
ON	OFF	ON	OFF	3° Pair					
ON	OFF	ON	ON	4° Pair					
ON	ON	OFF	OFF	5° Pair					
ON	ON	OFF	ON	6° Pair					
ON	ON	ON	OFF	7° Pair					
ON	ON	ON	ON	Single	OPEN PULSE				

 **To allow operation of the installed BUS accessories, store them on the board as described in paragraph 5.3.**

4.2 Terminal board J2 (outputs)

OUT 1 - Output 1 open-collector GND (terminal 13): The output can be set in one of the functions described in the Advanced Configuration (par. 6). The default value is **04** - Beam OPEN or in PAUSE. **Maximum load: 24 VDC with 100 mA.**

OUT 2 - Output 2 open-collector GND (terminal 15): The output can be set in one of the functions described in the Advanced Configuration (par. 6). The default value is **03** - CLOSED BEAM. **Maximum load: 24 VDC with 100 mA.**

OUT 3 - Output 3 open-collector GND (terminal 17): The output can be set in one of the functions described in the Advanced Configuration (par. 6). The default value is **19** - WARNING LAMP. **Maximum load: 24 VDC with 100 mA.**

OUT 4 - Relay output 4 (terminals 19, 20, 21): The output can be set in one of the functions described in Advanced Configuration (par. 6). The default value is **01** - BEAM ILLUMINATION. **Maximum load: 24 VDC with 800 mA.**

4.3 Terminal board J3 (external flashing lamp)

LAMP: to these terminals you can connect a 24VDC FAACLED external flashing lamp. *The integrated flashing traffic light must be connected independently to connector J15.*

 **The 24V FAACLIGHT with incandescent lamp cannot be connected to the J3 connector**

4.4 Terminal board J4 (loop detector)

LOOP 1: magnetic loop LOOP 1 (OPEN, terminals 24-25): for **OPENING**.

LOOP 2: magnetic loop LOOP 2 (SAFETY/CLOSE, terminals 26-27): for **SAFETY/CLOSING**.

4.5 Connector J5 (Motor)

Rapid connector for connecting the motor.

4.6 Connector J7 (Encoder)

The B680H barrier is equipped with a device for detecting the opening angle/bar position to ensure greater anti-crushing safety thanks to the possibility of reversing the direction of movement the moment in which an obstacle is detected. This device interfaces with the board through connector J7.

4.7 Connector J10 (Radio)

Used for the rapid connection of the Minidec, Decoder and RP / RP2 Receivers (see Fig. 28). If a 2-channel receiver is used, like the RP2, it will be possible to directly command automated system OPEN and CLOSE from a 2-channel radio control. If a 1-channel receiver is used, like the RP, it will only be possible to command OPEN. Connect the accessory with the components side facing the main strip of the board.

 **Boards should be inserted and removed ONLY after having cut off electrical power**

4.8 Connector J11 (Beam break-out sensor)

Designed for connecting the break-out sensor for the pivoting beam (if present). The sensor is optional. If it is not present, *do not remove* the installed jumper.

4.9 Connector J12 (Emergency battery)

This connector is for connecting a battery (optional) for ensuring automated system operation in case of temporary cut off of the main power supply.

4.10 Connector J13 (36VDC Power Supply)

This factory-wired connector powers the E680 board

4.11 Connector J15 (flashing traffic light)

This connector is for connecting the flashing traffic light built into the barrier head. The flashing traffic light visually signals barrier movement and, if needed, regulate access to the property using traffic light signals.

5. PROGRAMMING

The E680 board features 3 programming levels that make it entirely configurable and allow it to adapt the logics to any use. Each of the three levels can be accessed through a specific key combination.



Changes to the configuration parameters become effective immediately, while final storage occurs only upon exiting configuration and returning to the automated system status display. If the equipment is powered down before returning to the automated system status display, all changes made will be lost.

5.1 Basic configuration



To perform BASIC programming:

1. Press and hold button **F**; the name of the first function is displayed.
2. Release the button; the function value is displayed and can be modified using the + and - buttons.
3. Press and hold **F** again; the name of the following function is displayed, and so on.

The last function **St** lets you choose whether to save the configuration made (**y**) or exit without saving (**no**). Later, the display will resume showing the automated system status



You can go to **St** at any time. To exit programming, simultaneously press **F** and **-**.

BASIC CONFIGURATION 		
Display	Function	Default
df	Loading predefined parameter sets	00
	00 Neutral condition	
	01 Minimum mass	
	06 Maximum mass	
	Before automated system start-up, you must set the correct value, directly correlated to the length of the beam and the number and type of accessories installed. To determine said value, refer to Tables 4 and 5 on page 24	
	 WARNING: Setting a mass default lower than the one actually installed could cause irreversible damage to the bar and barrier structure.	
	If you do not wish to make any programming changes, leave the value 00 , otherwise selecting a value involves loading the chosen predefined parameters set (see paragraph 5.2).	
At	Currently loaded default	06
	This menu indicates the currently loaded default setting.	
	Given that parameter df has 00 as the predefined value (in order to provide a neutral access condition to the parameters), using the value in this menu makes it possible to identify the currently configured default setting.	
	Read-only parameter	

Display	Function	Default
bu	BUS accessories menu For functions associated with this parameter see paragraph 5.3	no
LO	Operating logics A Automatic AI Automatic 1 EP Semi-automatic P Parking PA Automatic parking Co Condo CA Automatic condo C Dead-man CU Custom	E
PA	Pause time Is effective only if an automatic logic is chosen; the value can be set from 0 to 59 sec. in one second steps. Next, the display changes to minutes and tenths of a second (separated by a decimal point) and time is adjusted in 10-second steps up to the maximum value of 4.1 minutes. e.g. if the display shows 2.5 , the pause time will be 2 minutes and 50 seconds.	20
So	Opening speed Adjusts the barrier opening speed. 00 Minimum speed 10 Maximum speed WARNING: Setting an excessive speed could cause irreversible damage to the bar and barrier structure.	10
Sc	Closing speed Adjusts the barrier closing speed. 00 Minimum speed 10 Maximum speed WARNING: Setting an excessive speed could cause irreversible damage to the bar and barrier structure.	02
L1	Loop 1 Activating this parameter, any loop that is connected to the Loop 1 input will serve as an OPEN function. y Loop 1 enabled no Loop 1 disabled Note: Should this function be disabled, the detection status of the loop will in any case remain available on one of the two outputs, if configured (see parameters ol...o4 in Advanced Configuration)	no

Display	Function	Default
L2	<p>Loop 2 Activating this parameter, any loop that is connected to the Loop 2 input will serve as a SAFETY/CLOSE function.</p> <p> y Loop 2 enabled no Loop 2 disabled (see note regarding Loop 1) </p>	no
S1	<p>Loop 1 sensitivity Adjusts the sensitivity of the vehicle detection loop</p> <p> 00 Minimum sensitivity 10 Maximum sensitivity </p>	05
S2	<p>Loop 2 sensitivity Adjusts the sensitivity of the vehicle detection loop</p> <p> 00 Minimum sensitivity 10 Maximum sensitivity </p>	05
Mt	<p>Motor movement Using the function provided by this parameter makes it possible to manually move the barrier bar, operating as <i>dead-man</i>. Pressing + will open the automated system, pressing - causes the automated system to close.</p> <p> op pressing +, open cl pressing -, close </p>	--
St	<p>AUTOMATED SYSTEM STATUS: This allows you to choose whether to quit the programme and save the data. y = quit and save the data no = quit without saving the data On quitting the programme, press the F key to display the status of the automated system</p> <p> 00 Beam closed 01 Beam open 02 Stationary ready to open 03 Stationary ready to close 04 Automated system paused 05 Opening 06 Closing 07 Failsafe in progress 08 2-EASY device verification in progress 09 Pre-flashing then OPENS 10 Pre-flashing then CLOSES 11 EMERGENCY Open </p> <p>You can go to St at any time by simultaneously pressing F and -.</p>	

 Displaying of the automated system status **St** is extremely important for the installing/maintenance technician in order to distinguish the logical processes that the board carries out during movement.

If, for example, the automated system status is CLOSED, the display MUST read **00**. When the OPEN command is received, the display will change to **09**, if pre-flashing is enabled, or directly to **05** (the OPENING movement) to then display **01** once the position of gate OPEN is reached. Example of a status sequence displayed starting from a closed barrier

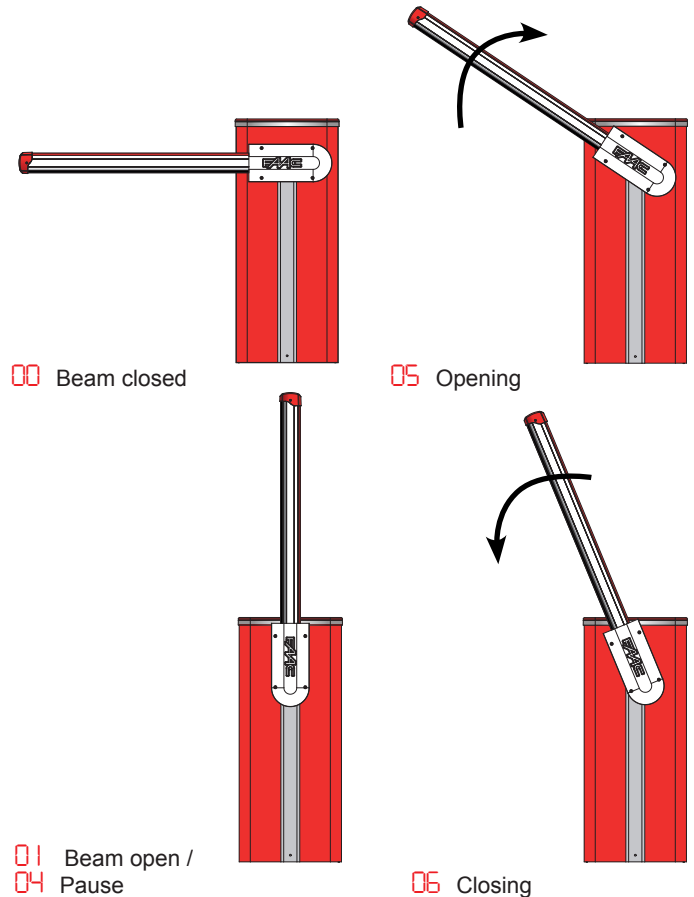

The sequence does not include statuses **09** and **10** which correspond to pre-flashing when opening and closing, respectively.

5.2 Changing the predefined parameters set

The E680 board features six sets of pre-defined configurations that allow rapid adapting to the size of the beam installed, making it the starting point for a fine adjustment of the parameters. To select one of the available configurations, you must change the parameter **dF** from the pre-set value **00** (neutral condition) to the value corresponding to the barrier configuration (beam length, type and number of accessories installed) shown in Tables 4 or 5 on page 24 (e.g. choose default **04** for a beam measuring 5 m in length with foot and lights).

To complete configuration, it is necessary to exit the Basic Configuration menu by pressing "F" until parameter **St** is reached or by pressing "F" and "-"

⚠ This operation changes the value of the parameters **S₀** and **S_C** in Basic configuration and **F₀, F_C, O_C** in Advanced configuration, setting them on the default values as shown in the tables in paragraph 6.3.

👉 Unlike the other parameters, the value of step **d_F** is not stored, thus allowing access to the menu through a neutral condition, which is the one displayed every time the configuration menu is opened..

If you do not wish to load any set of pre-defined parameters, leave parameter **S_t** on **00** and press "F" to go on to the next parameter

⚠ **Setting a set of pre-defined parameters that does not correspond to the actual configuration of the barrier could cause irreversible damage to the automated system, in particular if the default corresponds to a beam length shorter than the actual one.**

5.3 BUS accessories menu

The E680 board is designed to connect up to 8 pairs of BUS photocells. For the bus devices connected to the E680 board to be detected and managed by it, they must be stored on the board. To do this, proceed as follows:

- cut off power from the board.
- install and program the accessories using the desired address, depending on the function you wish to use (as described in paragraph 4.1.2)
- power up the board.
- access Basic Configuration, as described in paragraph 5.1
- once programming step **b_u** is reached, **n_o** will be displayed, indicating that here are no stored bus devices.
- to perform entry, simultaneously press and hold the + and - buttons for at least 5 seconds (during this time, the writing **n_o** will flash)
- once the procedure is completed, **y** will appear as confirmation.
- when + and - are released, the display will show the current status of the BUS devices, or **n_o** again, if there are no connected BUS devices.

The following image (Fig. 3) shows the correspondence of the various display segments to the different types of BUS devices that can be connected to the system:

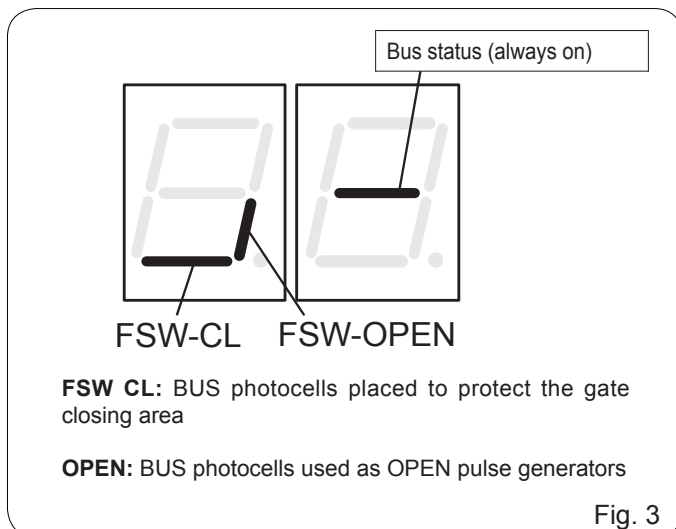

From the display of the status of the BUS devices, pressing the + key enables the types of BUS devices present to be verified. For example, the following photograph shows safety devices present during closing and a pair of photocells functioning as open pulse:

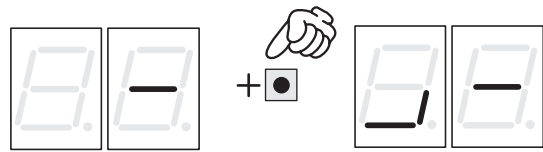

For the automated system to operate correctly, the status of the segments of the left-hand digit must correspond to the automated system at rest and without pulse generators or safeties engaged.

When the CLOSE photocells are engaged, the bottom segments will go on, as shown in the image to the side.



If the pair of OPEN pulse generator photocells is engaged, the display will show the configuration of segments shown in the image on the side of the page, in which the corresponding vertical segment is on, and will remain like this until the photocells are disengaged. If involved, the pair of OPEN pulse generator photocells commands opening of the automated system and prevents it from closing until it is disengaged, like a normal OPEN pulse received through terminal board J1 (terminal 3).

The BUS communication system uses a self-diagnostic function able to provide connection error signals or BUS accessories configuration error signal.

The display will show a flashing **CC** if there is a short circuit along the BUS line, as shown in the figure. To solve the problem it is necessary to carefully verify all the connections made.



The display will show a flashing **Er** as shown in the image on the side of the page, should more than one pair of photocells have the same address and in case of a calling or failsafe error. Ensure that the settings are correct, with reference to the indications given in paragraph 4.1.2



The status of the BUS and related input signals can also be seen by analysing the two LEDs DL1 (red) and DL2 (green), which make it possible to immediately verify if BUS communication is active or if there is an error, and if there are any active inputs or not. The status of the LEDs can be verified in the following tables:

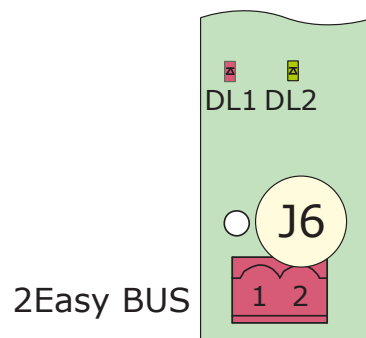

DL1 LED description (Red)

On	At least one of the inputs (safeties, OPEN pulse) is engaged or active
Off	No OPEN input is active and no safety device is engaged



DL2 LED description (Green)

On fixed	Normally active (LED on even if there are no devices connected)
Off	BUS-2EASY line short-circuited (flash every 2.5 sec.)
Rapid flashing	An error has been detected in the BUS-2EASY connection; repeat the acquisition procedure. If the error persists, check that: <ul style="list-style-type: none"> the system does not have more than one accessory with the same address (see also instructions regarding the accessories) make sure there is no calling error (number of devices connected is greater or less than that stored during setup)

6. Advanced Configuration

To access Advanced Configuration, press **F** and, while holding it, also press **+**:

- when **+** is released, the number of the first available function will appear
- when **F** is also released, the value is displayed, and can be changed using **+** and **-**
- pressing **F** again, and holding it, the name of the next parameter will be displayed; when released, the value can be changed using **+** and **-**
- once the last function has been reached, pressing **F** makes it possible to either save the previously changed parameters or exit without saving the changes; the display will go back to showing the status of the inputs.

ADVANCED CONFIGURATION  + 		
Display	Function	Default
FO	Opening motor power Adjusts the thrust of the motor during the opening phase. 00 Minimum power 50 Maximum power	40
FC	Closing motor power Adjusts the thrust of the motor during the closing phase. 00 Minimum power 50 Maximum power	40
PF	Pre-flashing This parameter is used to activate the flashing lamp for 5 seconds before the selected movement. no disabled OC before each movement CL before each closing movement OP before each opening movement PA only at the end of the pause	no

Display	Function	Default
EP	Pre-flashing time Pre-flashing time expressed in seconds. 00 minimum pre-flashing 10 maximum pre-flashing	00
OC	Sensitivity of obstacle during closing This determines the sensitivity to an obstacle before reversing takes place. 01 Minimum sensitivity 50 Maximum sensitivity	01
o1	Output 1 Setting this function makes it possible to modify the signal type of output 1, allowing high connection flexibility with external devices. 00 Failsafe 01 TYPE 1 BEAM ILLUMINATION (output active when beam closed, disabled with bar open or paused, intermittent when moving). Use only with output 4! 02 DISABLED 03 Beam CLOSED 04 Beam OPEN or in PAUSE, it goes off during closing pre-flashing. 05 Beam in OPENING MOVEMENT, including pre-flashing. 06 Beam in CLOSING MOVEMENT, including pre-flashing. 07 Beam STATIONARY 08 Beam in EMERGENCY mode 09 LOOP1 engaged 10 LOOP2 engaged 11 OPEN for E680 slave 12 CLOSE for E680 slave 13 Beam RELEASED 14 Not used 15 Not used 16 FCA engaged 17 FCC engaged 18 Not used 19 WARNING LAMP (on during opening and pause, flashing when closing, off when the automated system is closed)	04

Display	Function	Default
P1	Output 1 Polarity Allows setting of the output polarity: 4 output NC no output NO NOTE: if the output setting is 00 (Failsafe), keep the value set to no	no
o2	Output 2 Output 2 signal type, see "Output 1"	03
P2	Output 2 Polarity Output 2 polarity, see parameter regarding "Output 1 Polarity"	no
o3	Output 3 Output 3 signal type, see "Output 1"	19
P3	Output 3 Polarity Output 3 polarity, see parameter regarding "Output 1 Polarity"	no
o4	Output 4 Output 4 signal type, see "Output 1"	01
P4	Output 4 Polarity Output 4 polarity, see parameter regarding "Output 1 Polarity"	no
o5	Integrated flashing lamp operating mode Lets you choose between two operating modes for the integrated flashing lamp (if present) connected to output J15. 01 "Traffic light" mode (steady green when paused/open, flashing red when moving, steady red when closed) 02 "Flashing lamp" mode (flashing red when bar is moving, off in all other cases)	01
AS	Service request (linked to the following two functions): If activated, at the end of the countdown (which can be set with the two following "Cycle Programming" functions) it activates the LAMP output for 4 sec every 30 sec (service request). It can be useful for setting programmed maintenance work. 4 Active no Disabled	no
nC	Cycle programming in thousands: Is used to set a countdown of the system operation cycles; the value can be set from 0 to 99 (thousands of cycles). The value displayed is updated with the succession of the cycles, interacting with the value of nC (99 decrements of nC correspond to 1 decrement of nC). The function can be used, together with nC, to verify the use of the system and for use of "Service Request".	00

Display	Function	Default
nC	Cycle programming in hundreds of thousands: Is used to set a countdown of the system operation cycles; the value can be set from 0 to 99 (hundreds of thousands of cycles). The value displayed is updated with the succession of the cycles, interacting with the value of nC. (1 decrement of nC corresponds to 99 decrements of nC). The function can be used, together with nC, to verify the use of the system and for use of "Service Request".	01
St	AUTOMATED SYSTEM STATUS: This allows you to choose whether to quit the programme and save the data. 4 = quit and save the data no = quit without saving the data On quitting the programme, press the F key to display again the status of the automated system. You can go to St at any time by simultaneously pressing F and -	

6.1 Configuring the loop detector

The E680 board features an integrated metal mass detector for the induction detection of vehicles.

6.1.1 Specifications:

- Galvanic separation between the detector electronics and the loop electronics
- Automatic alignment of the system immediately following activation
- Continuous resetting of the frequency drifts
- Sensitivity independent of loop inductivity
- Adjustment of the loop work frequency with automatic selection
- Occupied loop message with LED display
- Loop status addressable on outputs OUT 1, OUT 2, OUT 3 and OUT 4

6.1.2 Connection:

Connect the detection loops according to the layout on page 7, Fig. 2

- Terminals 24 - 25 for LOOP 1 = loop with gate opening function;
- Terminals 26 - 27 for LOOP 2 = loop with closing and/or safety when closing function.

For more information on the effect of the loop signals on the automated system, refer to the logics tables in paragraph 10 "OPERATING LOGICS TABLE".

To enable the functionality of the connected loops, enter Basic configuration mode and set parameters L1 and L2 on 4 consistently with the number and type of connected loops. If only one loop is installed, enable only the corresponding programming step.

The loop detector operating status is indicated by the DL3 and DL4 status LEDs.

6.1.3 Calibration

Each time the E680 board is powered, the integrated loop detector performs a calibration of the connected loops. Therefore, you can perform calibration by cutting off power to the board for at least 10 seconds and then reconnecting it. From the barrier status display, you can press, at any time, **+** to calibrate the loop connected to the LOOP 1 input or **+** to calibrate the loop connected to the LOOP2 input.

Calibration is highlighted by the board diagnostics by flashing LEDs DL3 and DL4, and when calibration is completed, they will indicate the loop detection status, if connected. The other signals provided by the board diagnostics are described in the following table:

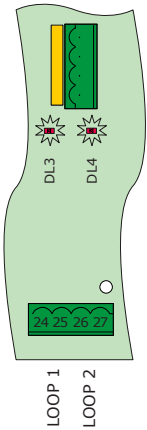

LED Status	LOOP Status
Off	Loop clear
On	Loop engaged
Flashing (0.5 s)	Loop calibration in progress
Rapid flashing	Loop short circuit
Slow flashing (5 s)	No loop or loop interrupted
Two flashes (every 5 s)	Non-conforming loop (heater or inductance out of range)

If one or both magnetic loops are not installed, the loop detector, following a first attempt to calibrate, will keep the status LEDs flashing every 5 seconds (as shown in the above table)

6.1.4 Adjusting sensitivity

By adjusting the sensitivity of the loop detector, you determine the variation of inductivity, for each channel, that a vehicle must cause in order to activate the corresponding detector output. Sensitivity is adjusted separately for each channel using the two parameters **S1** and **S2** in Basic configuration

6.1.5 Making the loops

The loop must be laid at least 15 cm from fixed metal objects, at least 50 cm from moving metal objects and no more than 5 cm from the surface of the final paving. Use a standard unipolar cable measuring 1.5 mm² in diameter (if the cable is laid below ground level directly, it must have double insulation). Make a preferably square or rectangular loop by preparing a PVC cable duct or by tracing the paving, as shown in figure 16 (the corners must be cut at a 45° angle to avoid cable breaks). Lay the cable using the number of windings shown in the table. The two ends of the cable must be twisted together (at least 20 times per metre) from the loop to the E680 board. Avoid splicing a cable (if necessary, weld the conductors and seal the splice using a heat-shrinking sheath) and keep it separate from the mains power lines.

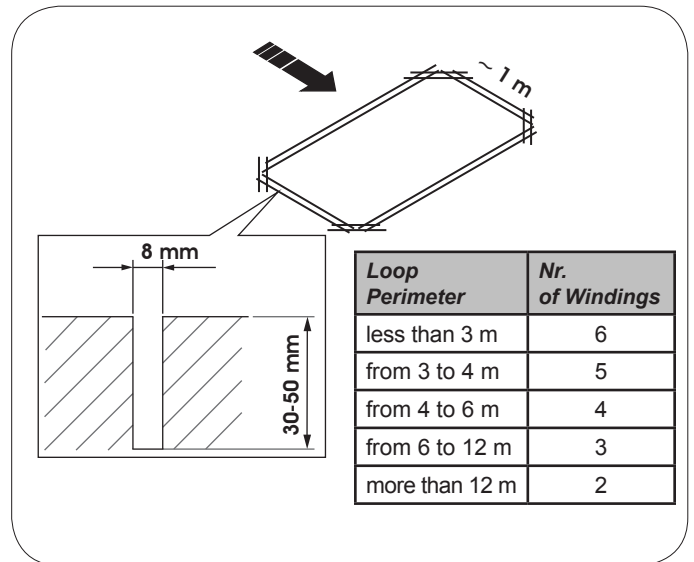

6.2 Expert Configuration

EXPERT configuration is used only in the event that operation logics customisation is already stored.

Before making changes at this level, be certain that the steps you wish to change and their effect on the automated system are fully understood.

Changing the third-level parameters involves indicating the **CU value on the **LO** parameter of the first-level programming**

To access EXPERT configuration, **press F and, holding it, press + for approximately 10 seconds.** The use of **F**, **+** and **-** in this menu is the same as in the other two programming levels

Display	Function	Setting
"EXPERT" CONFIGURATION F + + 10 sec		
01	If this function is activated, automatic closing occurs after the pause time.	Y = automatic closing no = disabled
02	If this function is activated, two distinct input operation mode is obtained: OPEN for opening and CLOSED for closing.	Y = 2-input operation no = disabled
03	Activation of recognition of the OPEN and CLOSE input levels (maintained command) . That is to say, the board recognises the level (if, for example, with OPEN held, you press STOP, when the latter is released, the automated system will continue to open). If 03 is disabled the board commands a manoeuvre only if there is an input variation.	Y = level recognition no = status variation recognition

04	Activation of DEAD-MAN opening (command always pressed). Releasing the OPEN command will stop operation	Y = active NO = disabled
05	When this function is activated, the OPEN command during opening will stop movement. If parameter 06 is NO the system is ready for opening. If parameter 06 is Y the system is ready for closing.	Y = when opening it stops NO = disabled
06	When this function is activated, the OPEN command during opening reverses movement. If parameters 05 and 06 are NO OPEN will have no effect during opening.	Y = when opening it reverses NO = disabled
07	When this function is activated, the OPEN command during pause stops operation. If parameters 07 and 08 are NO OPEN resets the pause time	Y = when in pause it stops NO = disabled
08	When this function is activated, the OPEN command during pause causes closing. If parameters 07 and 08 are NO OPEN resets the pause time.	Y = when in pause it closes NO = disabled
09	When this function is activated, the OPEN command during closing stops operation, otherwise it reverses movement.	Y = stops NO = reverses
10	Activation of DEAD-MAN closing (command always pressed). Releasing the CLOSE command will stop operation	Y = active NO = disabled
11	When this function is activated, the CLOSE command has priority over OPEN, otherwise OPEN has priority over CLOSE.	Y = active NO = disabled
12	When this function is activated, the CLOSE command commands closing when released. As long as CLOSE is activated, the unit stays in closing pre-flashing.	Y = closes when released NO = closes immediately
13	When this function is activated, the CLOSE command during opening stops operation, otherwise the CLOSE command commands reverse immediately or when opening is completed (see also parameter 14)	Y = CLOSE stops NO = CLOSE reverses
14	When this function is activated, and if parameter 13 is NO, the CLOSE command commands immediate closing at the end of the opening cycle (stores CLOSE). If parameters 13 and 14 are NO CLOSE commands immediate closing.	Y = closes at the end of opening NO = immediate closing
15	When this function is activated, with the system blocked by a STOP, a next OPEN moves in the opposite direction. If parameter 15 is NO it always closes.	Y = moves in the opposite direction NO = always closes
16	When this function is activated, during closing, the CLOSING SAFETIES stop and allow motion to resume when they are disengaged, otherwise they immediately reverse opening.	Y = closes when disengaged NO = immediate reverse
17	When this function is activated, the CLOSING SAFETIES command closing when they are disengaged (see also parameter 18).	Y = closing when FSW is disengaged NO = disabled
18	When this function is activated, and if parameter 17 is Y, the unit will wait for the opening cycle to end before executing the closing command provided by the CLOSING SAFETIES .	Y = closes at the end of opening NO = disabled
19	When this function is activated, during closing, LOOP2 stops and allows motion to resume when it is disengaged, otherwise it immediately reverses opening.	Y = closes when disengaged NO = immediate reverse
20	When this function is activated, LOOP2 commands closing when it is disengaged (see also parameter 21).	Y = closes if LOOP2 is clear NO = disabled
21	When this function is activated, and if parameter 21 is Y, the unit will wait for the opening cycle to end before executing the closing command provided by LOOP2 .	Y = closes at the end of opening NO = disabled
22	When this function is activated: in case of a blackout, once electrical power has been restored, if an OPEN command is not active the automated system recloses immediately.	Y = active NO = disabled
23	LOOP 1 commands opening and, once completed, it closes if disengaged (useful in case of vehicle backing-up with consecutive loops). If disabled, when LOOP 1 is disengaged, it does not close.	Y = closes if LOOP1 clear NO = disabled
24	When this function is activated, an open or close command is only carried out after the safeties have been disengaged.	Y = active NO = disabled
25	A.D.M.A.P. function When this function is activated, the result is operation of safeties compliant with French regulations .	Y = active NO = disabled

26	When this function is activated, the CLOSING SAFETIES during closing stop and reverse movement when they are disengaged, otherwise they reverse immediately.	Y = stops and reverses when disengaged. no = reverses immediately.
27	DO NOT CHANGE	no
28	DO NOT CHANGE	no
29	DO NOT CHANGE	no
30	When this function is activated, the LOOP1 commands are prioritised rather than the LOOP2 commands.	Y = active no = disabled
A0	HOLD CLOSE / HOLD OPEN function When this function is activated, the automated system will monitor the position of the beam at set intervals (see parameter A1). If the beam is not completely closed or completely open (depending on the logical condition of the board), the automated system will command a CLOSE or OPEN movement to bring the beam back to the correct position, for a maximum of 3 seconds. If, when the 3 seconds have elapsed, the bar does not go back to completely closed/open position (e.g. because the bar is blocked), the function will be disabled until the next OPEN command is received.	Y
A1	HOLD CLOSE / HOLD OPEN function activation time This parameter indicates the time interval between two activations of the HOLD OPEN / HOLD CLOSE function, expressed in minutes. (from 00 to 99)	60
r1	Loop 1 frequency reading This menu item lets you verify the reading of the current oscillation frequency of the loop connected to the Loop 1 input. The indication should be read as follows: First digit: tens (kHz) Second digit: units (kHz) Decimal point: hundreds (kHz) For example, the reading 05. refers to a reading of 105 kHz Read-only parameter	
r2	Loop 2 frequency reading This menu item lets you verify the reading of the current oscillation frequency of the loop connected to the Loop 2 input. (see parameter r1 for explanations on how to read the indicated value) Read-only parameter	
F1	Loop 1 frequency selection This parameter lets you set an oscillation frequency specific to the loop connected to the Loop 1 input, or lets the system choose the most adequate setting among the 4 available. A Automatic selection 1-2-3-4 Frequency 1-2-3-4 Note: When you exit the Advanced configuration menu after having changed the loop operation frequency setting, the system will be recalibrated. This will provide an updated frequency reading once you re-enter the menu to consult the values of parameters r1 or r2	A
F2	Loop 2 frequency selection This parameter lets you set an oscillation frequency specific to the loop connected to the Loop 2 input, or lets the system choose the most adequate setting among the 4 available. A Automatic selection 1-2-3-4 Frequency 1-2-3-4 Note: When you exit the Advanced configuration menu after having changed the loop operation frequency setting, the system will be recalibrated. This will provide an updated frequency reading once you re-enter the menu to consult the values of parameters r1 or r2	A

h1	LOOP 1 holding time Is used to set presence time on loop 1. When this time has elapsed, the board will self-calibrate and signal "loop clear" (LED DL3 off). When the board is turned on, an automatic reset is carried out. y 5 minutes no infinite	no
h2	LOOP 2 holding time Is used to set presence time on loop 2. When this time has elapsed, the board will self-calibrate and signal "loop clear" (LED DL4 off). When the board is turned on, an automatic reset is carried out. y 5 minutes no infinite	no
H1	Loop 1 articulated lorry function This function lets you increase the level of sensitivity at the time of detection, to allow correct detection even in case of very tall vehicles or during the transit of a tractor and trailer. y enabled no disabled	y
H2	Loop 2 articulated lorry function This function lets you increase the level of sensitivity at the time of detection, to allow correct detection even in case of very tall vehicles or during the transit of a tractor and trailer. y enabled no disabled	y
t	Work time (time-out) Maximum work time of the automated system before the motor stops, if the open or close position is not reached. The value can be set from 0 to 59 sec. in one second steps. Next, the display changes to minutes and tenths of a second (separated by a decimal point) and time is adjusted in 10-second steps up to the maximum value of 4.1 minutes.	30
St	STATUS OF THE AUTOMATED SYSTEM: Exit from programming, storage of data and automated system status display.	

6.3 Pre-Defined Parameter Sets

The table below shows, for each set of pre-defined parameters, the values that they will load in the board memory.

Basic Configuration

dF	01	02	03	04	05	06
At	01	02	03	04	05	06
bu						
L0	E	E	E	E	E	E
PA	20	20	20	20	20	20
So	10	10	10	10	10	10
Sc	10	05	05	04	02	02
L1	no	no	no	no	no	no
L2	no	no	no	no	no	no
S1	05	05	05	05	05	05
S2	05	05	05	05	05	05

Advanced Configuration

The following table shows, for each set of pre-defined parameters, the values that they will load in the board memory, in advanced configuration.

dF	01	02	03	04	05	06
F0	25	25	30	28	30	40
FC	25	25	30	28	30	40
PF	no	no	no	no	no	no
tP	00	00	00	00	00	00
oc	35	35	38	32	32	32
FS	no	no	no	no	no	no
a1	00	00	00	00	00	00
P1	no	no	no	no	no	no
a2	03	03	03	03	03	03
P2	no	no	no	no	no	no
a3	01	01	01	01	01	01
P3	no	no	no	no	no	no
a4	02	02	02	02	02	02
P4	no	no	no	no	no	no
a5	01	01	01	01	01	01
AS	no	no	no	no	no	no
nc	00	00	00	00	00	00
nC	00	00	00	00	00	00

6.4 "Expert" default parameters

The following table contains the pre-defined settings that characterize the various operation logics.

Step.	A	A1	E	P	PA	Cn	Ca	C
01	Y	Y	N	N	Y	N	Y	N
02	N	N	N	Y	Y	Y	Y	Y
03	N	N	N	N	N	N	N	N
04	N	N	N	N	N	N	N	Y
05	N	N	Y	N	N	N	N	N
06	N	N	Y	N	N	N	N	N
07	N	N	N	N	N	N	N	N
08	N	N	N	N	N	N	N	N
09	N	N	N	N	N	N	N	N
10	N	N	N	N	N	N	N	Y
11	N	N	N	N	N	N	N	N
12	N	N	N	Y	Y	N	N	N
13	N	N	N	N	N	N	N	N
14	N	N	N	Y	Y	Y	Y	N
15	N	N	N	N	N	N	N	N
16	N	N	N	Y	Y	N	N	N
17	N	Y	N	N	N	N	N	N
18	N	Y	N	N	N	N	N	N
19	N	N	N	Y	Y	N	N	N
20	N	Y	N	Y	Y	Y	Y	N
21	N	Y	N	Y	Y	Y	Y	N
22	N	N	N	N	N	N	N	N
23	N	N	N	Y	Y	N	N	N
24	N	N	N	N	N	N	N	N
25	N	N	N	N	N	N	N	N
26	N	N	N	N	N	N	N	N
27	N	N	N	N	N	N	N	N
28	N	N	N	N	N	N	N	N
29	N	N	N	N	N	N	N	N
30	N	N	N	N	N	Y	Y	N

7. START-UP

7.1 Verifying the diagnostic LEDs

Before starting up the board, it is necessary to verify that the status of the diagnostic LEDs corresponds to the logic. Said status must coincide with the indications in Fig. 4, situation which reflects that of an automated system that is CLOSED and ready to open.

 The FSW, STOP and ALARM LEDs are safety inputs with NC contacts, therefore the related LEDs must be ON when the automated system is at rest, and go off when the device connected is engaged.

 The OPEN and CLOSE inputs are NO contact inputs, therefore the related LEDs must be OFF when the automated system is at rest, and go on when the device connected is active.

 The BUS status must correspond to DL2 (green) on fixed and DL1 (red) off. The BUS menu of the Basic configuration must display the indication shown to the side confirming the fact that there are no engaged photocells or active pulse generators.



Fig. 4

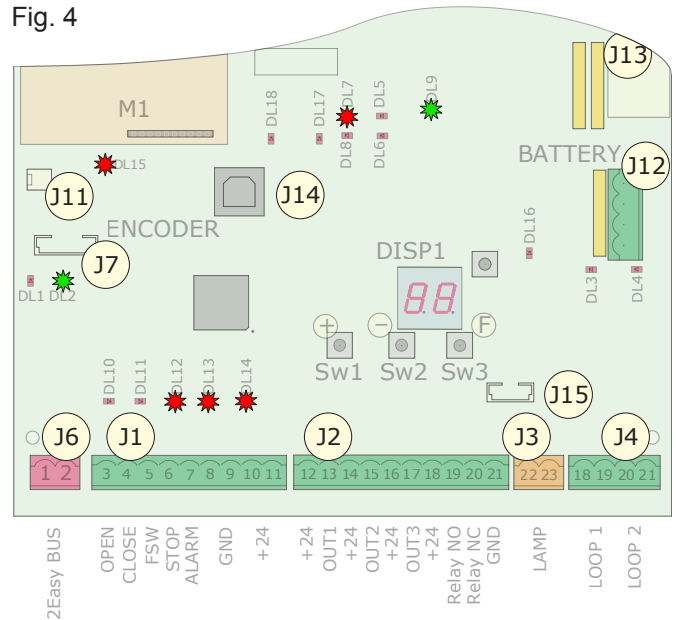

7.2 Setup

Before being put into operation, the E680 board requires a setup procedure during which the automated system determines the rotation angle of the beam and consequently its travel. These measurements allow correct management of motor decelerations and acceleration ramps.

 At first start-up the board will signal the need for a setup cycle, by displaying a flashing 50.

For setup, proceed as follows:

- Using the parameter "Mt" in Basic configuration mode, check that the opening / closing movement corresponds to the pressed key (+ / -); if not, go to the motor wiring and reverse the two conductors L1 and L3, as shown in Fig. 14, Ref. ④
- Place the automated system in closing position using the parameter "Mt" in Basic configuration mode or using the release device, as shown in paragraphs 6 and 7 on page 4.
- Press and hold SW4 ("SETUP" programming key) until the automated system begins a slow opening movement. On the display 51 will flash indicating the start of the procedure.
- Once the maximum opening position is reached, the automated system will stop automatically.
- Next, the automated system will start the beam closing movement. The display will flash the indication 53.
- Once the closing position has been reached, the automated system will stop automatically and the display will go back to showing the indication of the current status of the automated system (00 - closed).

8. TESTING THE AUTOMATED SYSTEM

Once programming is completed, ensure that the system is operating correctly.

Verify especially the correct regulation of the automated system power and correct operation of the safety devices it is connected to and verify that the automated system conforms to current safety standards.

9. MASTER/SLAVE CONFIGURATION

If the installation contemplates the gate area being covered by two opposing barriers, a Master / Slave configuration may be used for the boards which will activate the two barriers. This configuration permits connection of the command and safety signals to be simplified (they are all connected to just one board), also ensuring perfect synchronisation of the two automated systems.

“MASTER device” means the board to which all the pulse generators and safety devices are connected.

“SLAVE device” means the board which is controlled by the MASTER through pulse inputs, while the safety inputs are bypassed.

The electrical connections and the parameters needed for correct functioning of the system in a Master / Slave configuration are shown in the following diagram:

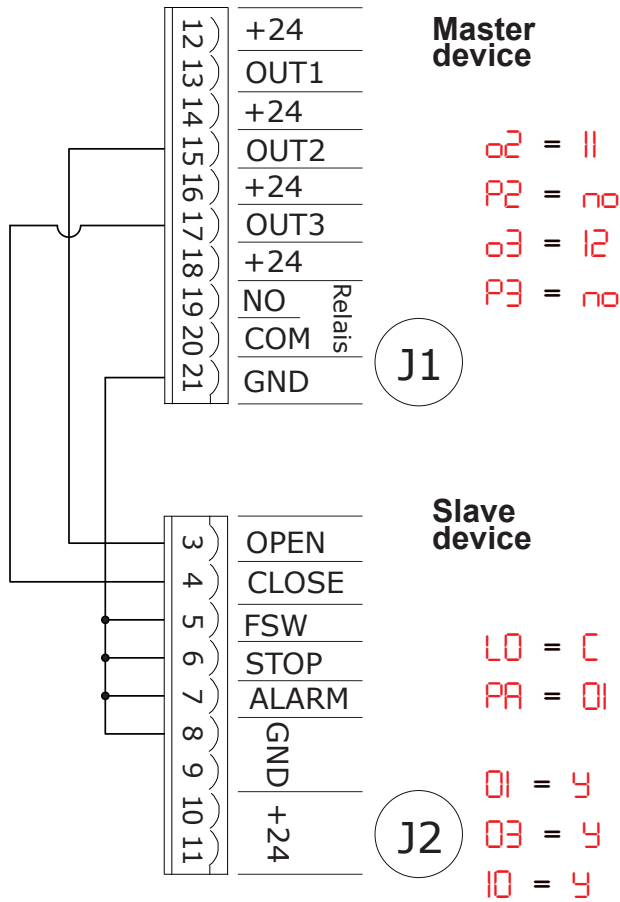

10. INTERLOCK

The interlock function enables two in-line barriers to be managed (see fig.) so that opening of one is subordinated to closing of the other. Operation can be one-way or two-way.

For in-line barriers, set OUT1 INTERLOCK to parameter 18 (see 2nd LEVEL PROG.) on both boards and connect them as in figure.

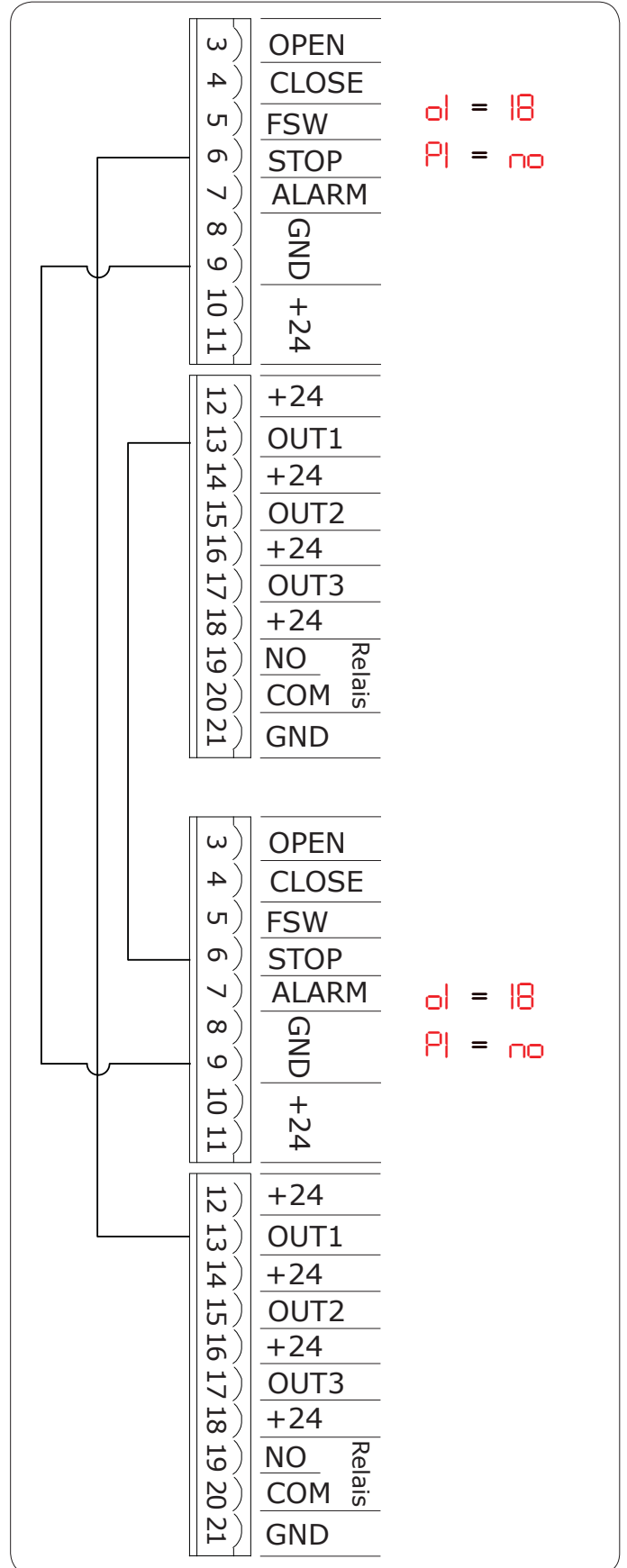

ENGLISH

11. OPERATING LOGICS TABLE

Tab. 1/a

LOGIC "A"	PULSES					
AUTOMATED SYSTEM STATUS	OPEN A	CLOSE	STOP	FSW	LOOP 1	LOOP 2
CLOSED	opens and closes after the pause time	no effect	no effect (opening inhibited)	no effect	opens and closes after the pause time	no effect
WHEN OPENING	no effect	immediately reverses to closing	blocks operation	no effect	no effect	no effect
OPEN IN PAUSE	resets pause time	closes	blocks operation	resets pause time (closing inhibited)	resets pause time	resets pause time (closing inhibited)
WHEN CLOSING	immediately reverses to opening	no effect	blocks operation	immediately reverses to opening	immediately reverses to opening	immediately reverses to opening
BLOCKED	closes	closes	no effect (opening and closing inhibited)	no effect (closing inhibited)	opens and closes after the pause time	no effect (closing inhibited)

Tab. 1/b

LOGIC "A1"	PULSES					
AUTOMATED SYSTEM STATUS	OPEN A	CLOSE	STOP	FSW	LOOP 1	LOOP 2
CLOSED	opens and closes after the pause time	no effect	no effect (opening inhibited)	no effect	opens and closes after the pause time	no effect
WHEN OPENING	no effect	immediately reverses to closing	blocks operation	closes immediately after opening is completed	no effect	closes immediately after opening is completed
OPEN IN PAUSE	resets pause time	closes	blocks operation	closes	resets pause time	closes when disengaged
WHEN CLOSING	immediately reverses to opening	no effect	blocks operation	immediately reverses to opening	immediately reverses to opening, closes at the end of pause	immediately reverses to opening, closes again once opening is completed
BLOCKED	closes	closes	no effect (opening and closing inhibited)	inhibits closing	opens and closes after the pause time	no effect (closing inhibited)

Tab. 1/c

LOGIC "E"	PULSES					
AUTOMATED SYSTEM STATUS	OPEN A	CLOSE	STOP	FSW	LOOP 1	LOOP 2
CLOSED	opens	no effect	no effect (opening inhibited)	no effect	opens	no effect
WHEN OPENING	blocks operation	immediately reverses to closing	blocks operation	no effect	no effect	no effect
OPEN	closes	closes	no effect (closing inhibited)	no effect (closing inhibited)	no effect	no effect (closing inhibited)
WHEN CLOSING	immediately reverses to opening	no effect	blocks operation	immediately reverses to opening	immediately reverses to opening	immediately reverses to opening
BLOCKED	closes	closes	no effect (opening and closing inhibited)	no effect (closing inhibited)	opens	no effect (closing inhibited)

↻ In brackets, the effects on the other inputs when the pulse is active

Tab. 1/d

LOGIC "P"	PULSES					
AUTOMATED SYSTEM STATUS	OPEN A	CLOSE	STOP	FSW	LOOP 1	LOOP 2
CLOSED	opens	no effect	no effect (opening inhibited)	no effect	opens and once opening is completed closes if disengaged	no effect
WHEN OPENING	no effect	closes immediately after opening is completed	blocks operation	no effect	no effect	closes immediately after opening is completed
OPEN	no effect (closing inhibited)	closes	no effect (closing inhibited)	no effect (closing inhibited)	prevents closing	closes when disengaged
WHEN CLOSING	immediately reverses to opening	no effect	blocks operation	blocks and when disengaged continues to close	immediately reverses to opening, and once opening is completed closes if disengaged	blocks and when disengaged continues to close
BLOCKED	opens	closes	no effect (opening and closing inhibited)	no effect (closing inhibited)	opens and once opening is completed closes if disengaged	no effect (closing inhibited)

Tab. 1/e

LOGIC "PA"	PULSES					
AUTOMATED SYSTEM STATUS	OPEN A	CLOSE	STOP	FSW	LOOP 1	LOOP 2
CLOSED	opens and closes after the pause time	no effect	no effect (opening inhibited)	no effect	opens and once opening is completed closes if disengaged	no effect
WHEN OPENING	no effect	closes immediately after opening is completed	blocks operation	no effect	no effect	closes immediately after opening is completed
OPEN IN PAUSE	resets pause time	closes	blocks operation	resets pause time (closing inhibited)	resets pause time	closes when disengaged
WHEN CLOSING	immediately reverses to opening	no effect	blocks operation	blocks and when disengaged continues to close	immediately reverses to opening, and once opening is completed closes if disengaged	blocks and when disengaged continues to close
BLOCKED	opens and closes after the pause time	closes	no effect (opening and closing inhibited)	no effect (closing inhibited)	opens and once opening is completed closes if disengaged	no effect (closing inhibited)

Tab. 1/f

LOGIC "Cn"	PULSES					
AUTOMATED SYSTEM STATUS	OPEN A	CLOSE	STOP	FSW	LOOP 1	LOOP 2
CLOSED	opens	no effect	no effect (opening inhibited)	no effect	opens	no effect
WHEN OPENING	no effect	closes immediately after opening is completed	blocks operation	no effect	no effect	closes immediately after opening is completed
OPEN	no effect (closing inhibited)	closes	no effect (closing inhibited)	no effect (closing inhibited)	no effect	closes when disengaged
WHEN CLOSING	immediately reverses to opening	no effect	blocks operation	reverses to opening and closes after pause time	immediately reverses to opening	immediately reverses to opening
BLOCKED	opens	closes	no effect (opening and closing inhibited)	no effect (closing inhibited)	opens	no effect (closing inhibited)

↻ In brackets, the effects on the other inputs when the pulse is active

Tab. 1/g

LOGIC "CA"	PULSES					
AUTOMATED SYSTEM STATUS	OPEN A	CLOSE	STOP	FSW	LOOP 1	LOOP 2
CLOSED	opens and closes after the pause time	no effect	no effect (opening inhibited)	no effect	opens and closes after the pause time	no effect
WHEN OPENING	no effect	closes immediately after opening is completed	blocks operation	no effect	no effect	closes immediately after opening is completed
OPEN IN PAUSE	resets pause time	closes	blocks operation	resets pause time (closing inhibited)	resets pause time	closes when disengaged
WHEN CLOSING	immediately reverses to opening	no effect	blocks operation	reverses to opening and closes after pause time	immediately reverses to opening	immediately reverses to opening
BLOCKED	opens and closes after the pause time	closes	no effect (opening and closing inhibited)	no effect (closing inhibited)	opens and closes after the pause time	no effect (closing inhibited)

Tab. 1/h

LOGIC "C"	MAINTAINED COMMANDS		PULSES			
AUTOMATED SYSTEM STATUS	OPEN A	CLOSE	STOP	FSW	LOOP 1	LOOP 2
CLOSED	opens	no effect	no effect (opening inhibited)	no effect	no effect	no effect
WHEN OPENING	/	no effect	blocks operation	no effect	no effect	no effect
OPEN	no effect (closing inhibited)	closes	blocks operation	no effect	no effect (closing inhibited)	no effect (closing inhibited)
WHEN CLOSING	immediately reverses to opening	/	blocks operation	blocks operation	blocks operation	blocks operation
BLOCKED	opens	closes	no effect (opening and closing inhibited)	no effect (closing inhibited)	no effect (closing inhibited)	no effect (closing inhibited)

↻ In brackets, the effects on the other inputs when the pulse is active

12. BALANCING TABLES

The following two tables indicate the fixing position of the pistons on the rocker arm in relation to the length of the beam and the presence of accessories secured to it, if any.

Table 2 refers to the balance spring for bar lengths equal to or shorter than 5 m and featuring a profile corresponding to the one in Fig. 8 on page 25, ref. ① ("S" profile).

Table 3 refers to the balance spring for bar lengths equal to or longer than 5 m and featuring a profile corresponding to the one in Fig. 8 on page 25, ref. ② ("L" profile).

Figure 30 contains the key for identifying the fixing holes based on the number indicated in the tables.

Table 2

Bar length → Installed accessories ↓	2 m	2,5 m	3 m	3,5 m	4m	4 m (with coupling)	4,5 m	5 m	5 m (with coupling)
No accessories	1	2	3	4	4	5	6	6	6
Lights	1	2	3	4	4	5	6	6	
Lights / Skirt	1	2	4	5	6	6	6		
Lights / Foot / Skirt	2	3	4	6	6	6	6		
Lights / Foot	2	3	3	5	6	6	6		
Foot	1	2	3	5	6	6	6		
Skirt	1	2	3	4	6	6	6		
Skirt/Foot	2	3	4	5	6	6	6		

Table 3

Bar length → Installed accessories ↓	5 m (without coupling)	5 m	5,5 m	6 m	6,5 m	7 m	7,5 m	8 m
No accessories	2	2	3	3	4	4	4	5
Lights	2	2	3	3	4	4	5	6
Lights / Skirt	2	3	3	4	4	5	6	
Lights / Foot / Skirt	3	3	4	4	5	6		
Lights / Foot	2	3	3	4	4	5	6	6
Foot	2	3	3	4	4	4	5	6
Skirt	2	3	3	4	4	5	6	
Skirt/Foot	3	3	3	4	4	5		

ENGLISH

13. DEFAULT SELECTION TABLES (dF parameter)

The purpose of the two following tables is to determine, depending on the length of the bar and the number and type of accessories installed, the correct default value to set in the first Basic programming function.

Table 4 refers to the balance spring for bar lengths equal to or shorter than 5 m and featuring a profile corresponding to the one in Fig. 8 on page 25, ref. ① ("S" profile).

Table 5 refers to the balance spring for bar lengths equal to or longer than 5 m and featuring a profile corresponding to the one in Fig. 8 on page 25, ref. ② ("L" profile).

The key to symbols for identifying the fixing holes based on the number indicated in the tables is shown in Fig. 30.

Table 4

Bar length → Installed accessories ↓	2 m	2,5 m	3 m	3,5 m	4m	4 m (with coupling)	4,5 m	5 m	5 m (with coupling)
No accessories	1	1	2	2	2	3	3	3	3
Lights	1	1	2	2	2	3	3	3	
Lights / Skirt	1	1	2	3	3	3	3		
Lights / Foot / Skirt	1	2	2	3	3	3	3		
Lights / Foot	1	2	2	3	3	3	3		
Foot	1	1	2	3	3	3	3		
Skirt	1	1	2	2	3	3	3		
Skirt/Foot	1	2	2	3	3	3	3		

Table 5

Bar length → Installed accessories ↓	5 m (without coupling)	5 m	5,5 m	6 m	6,5 m	7 m	7,5 m	8 m
No accessories	4	4	5	5	5	5	5	6
Lights	4	4	5	5	5	5	6	6
Lights / Skirt	4	5	5	6	6	6	6	
Lights / Foot / Skirt	5	5	5	5	6	6		
Lights / Foot	4	5	5	5	5	6	6	6
Foot	4	5	5	5	5	5	6	6
Skirt	4	5	5	5	5	6	6	
Skirt/Foot	5	5	5	5	5	6		



Raccolta immagini - Pictures collection - Collection d'images - Photo Kollection - Conjunto de imagenes - Afbeeldingen

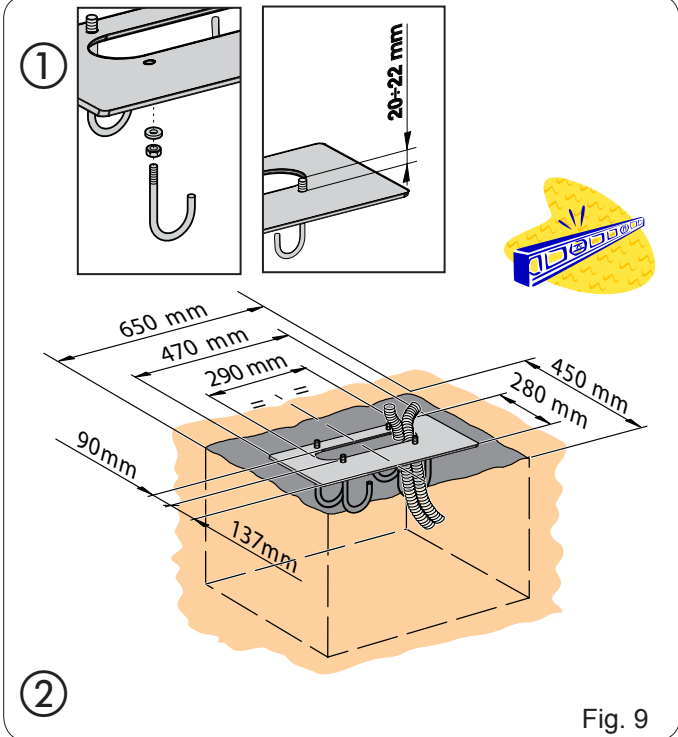
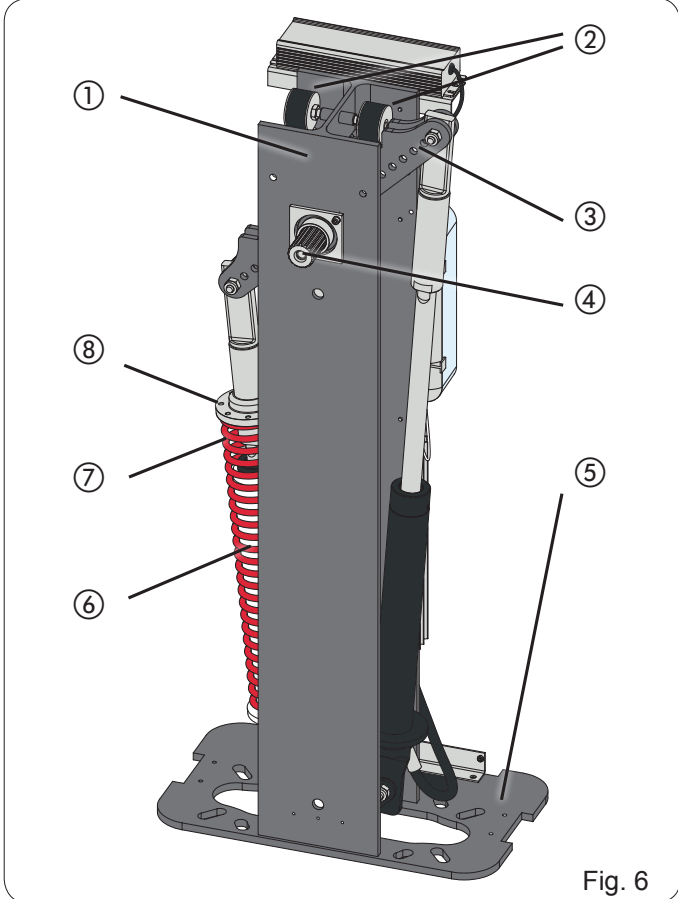
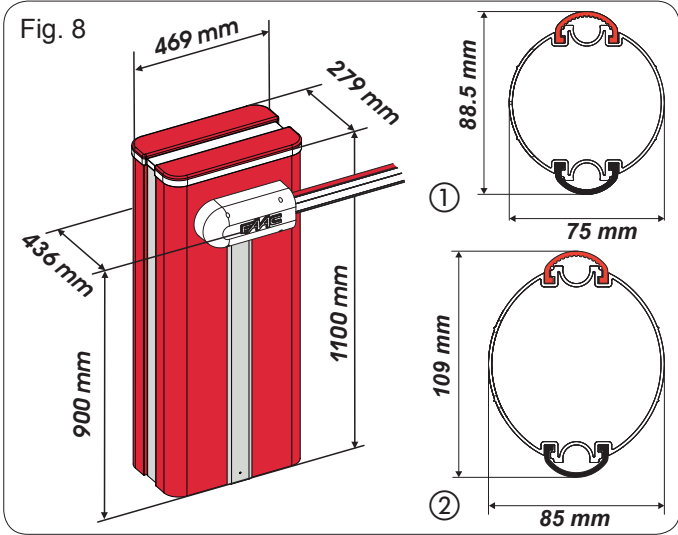
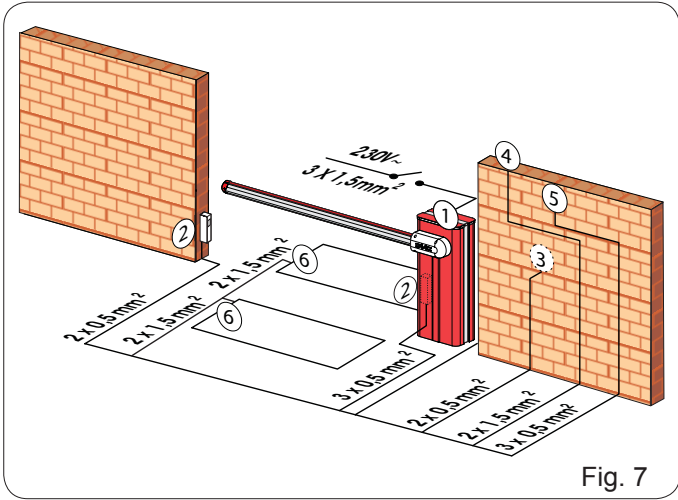
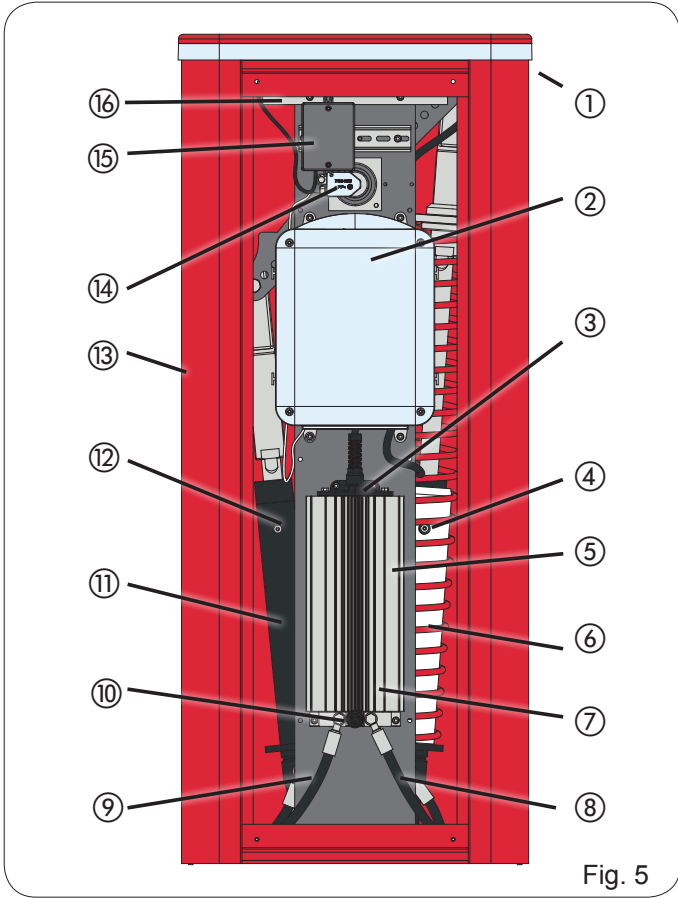

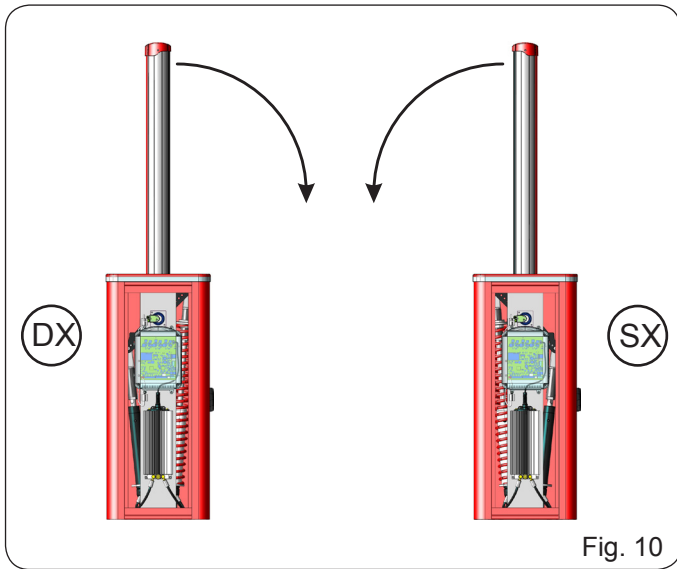

Fig. 10

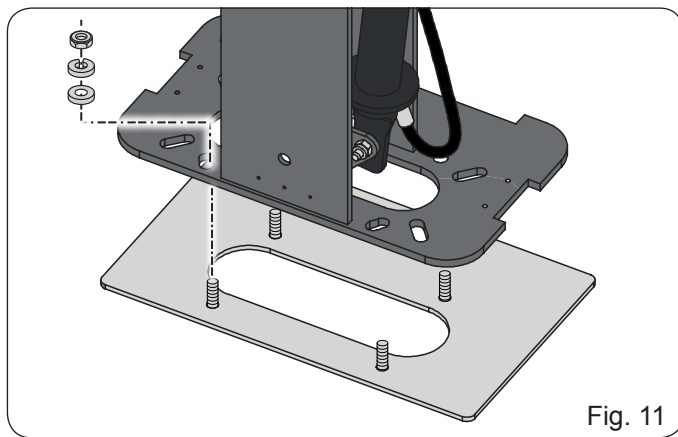

Fig. 11

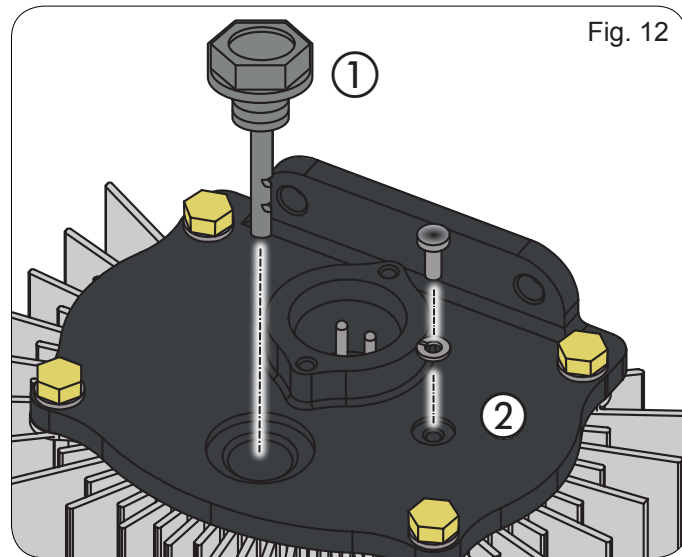

Fig. 12

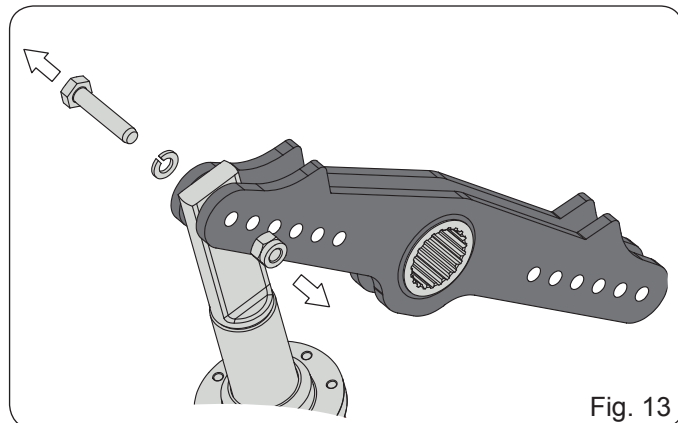

Fig. 13

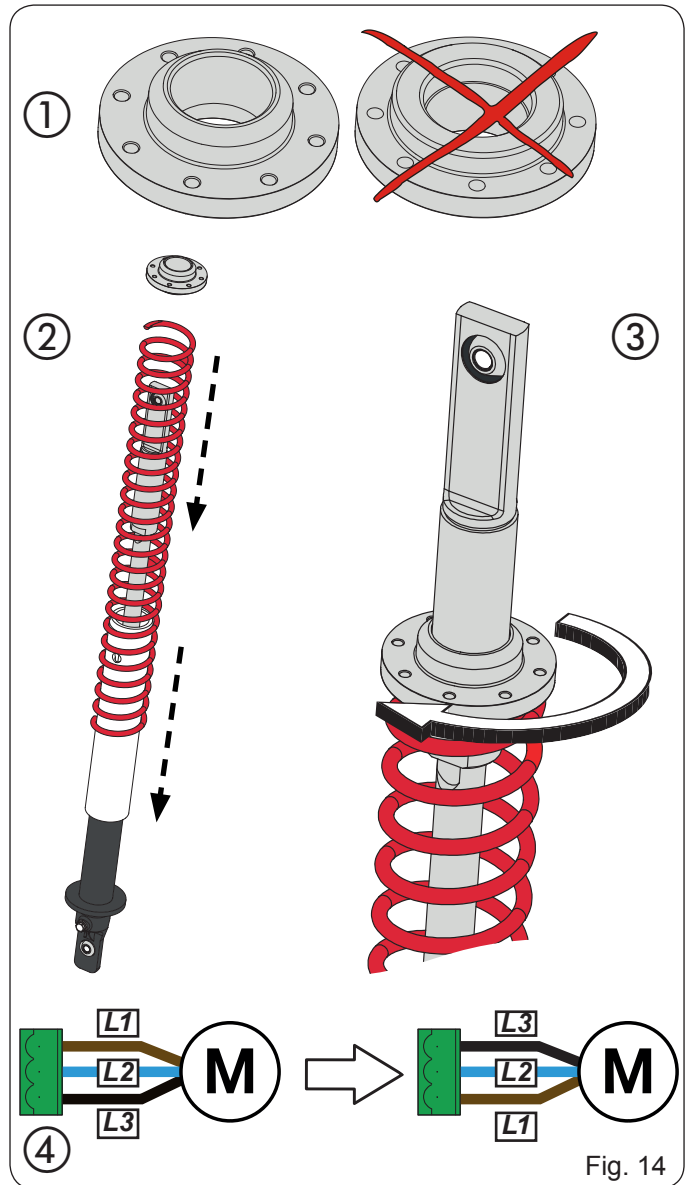

Fig. 14

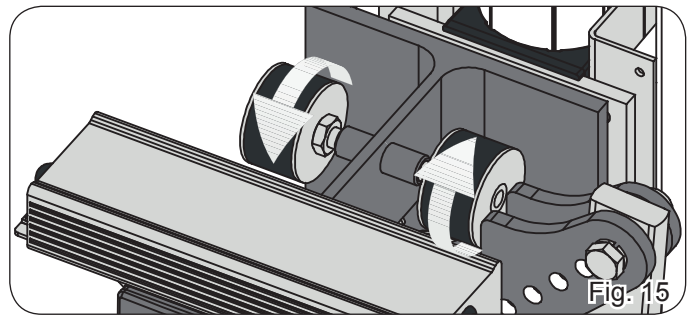

Fig. 15

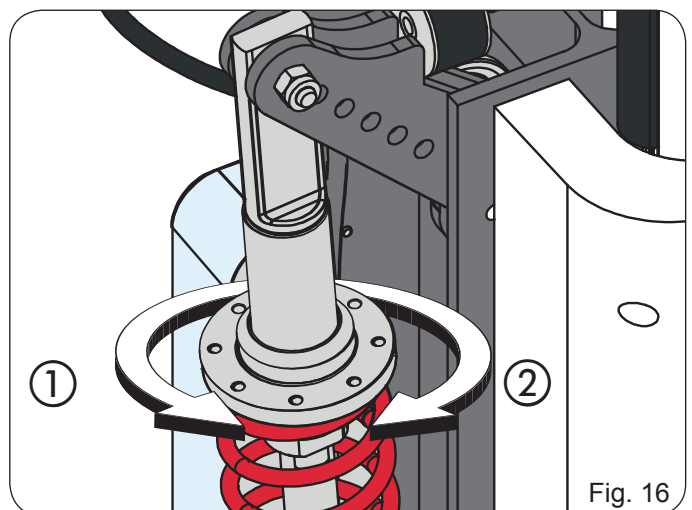
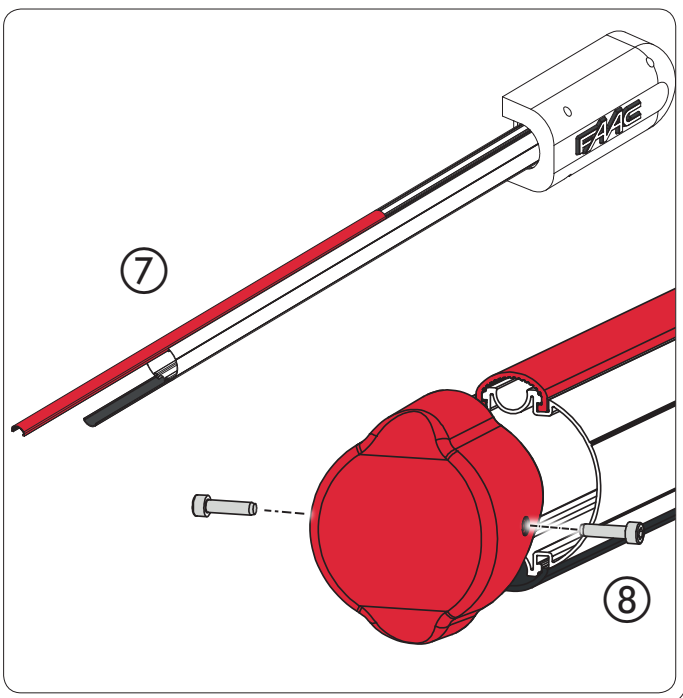
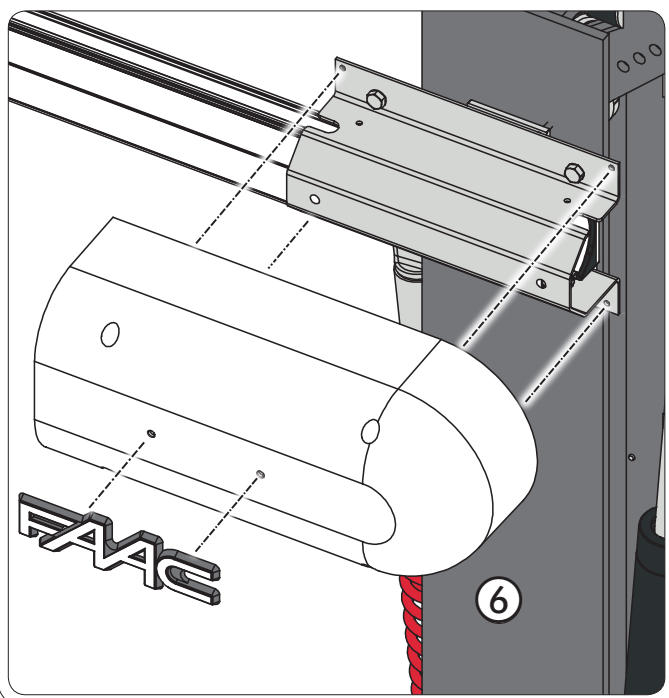
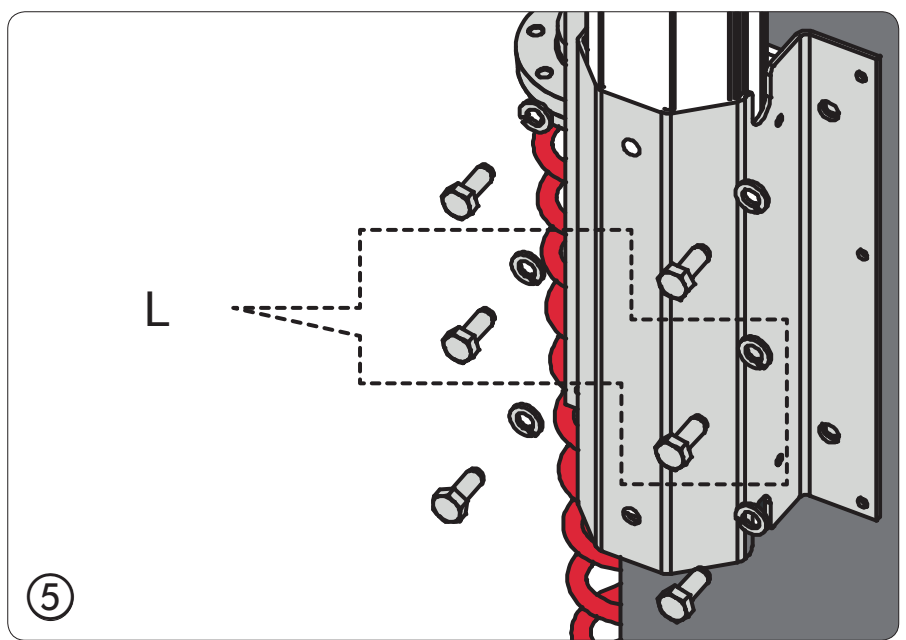
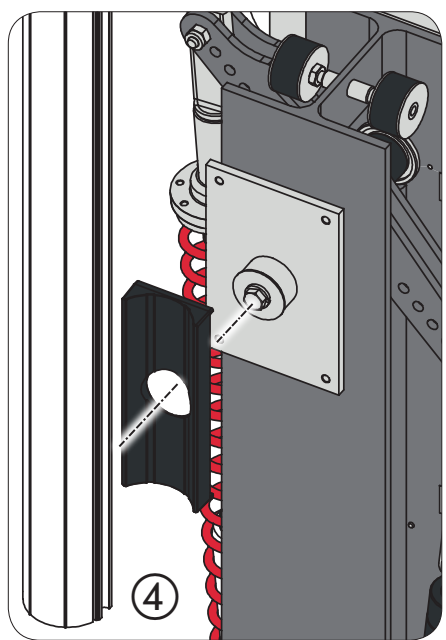
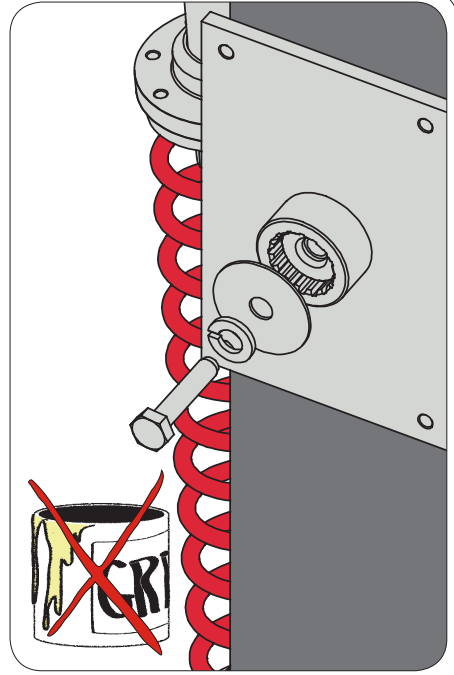
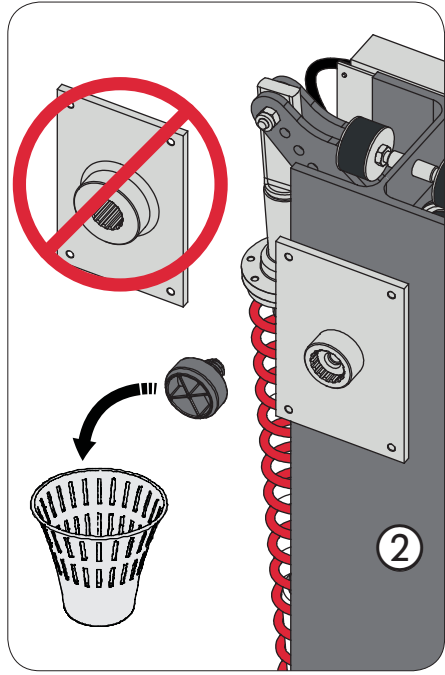
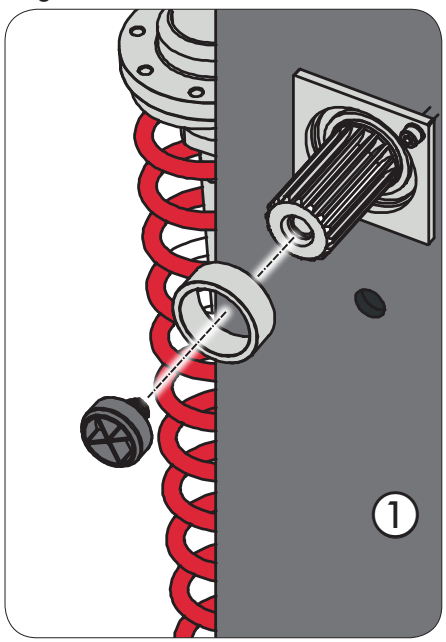

Fig. 16



Fig. 17



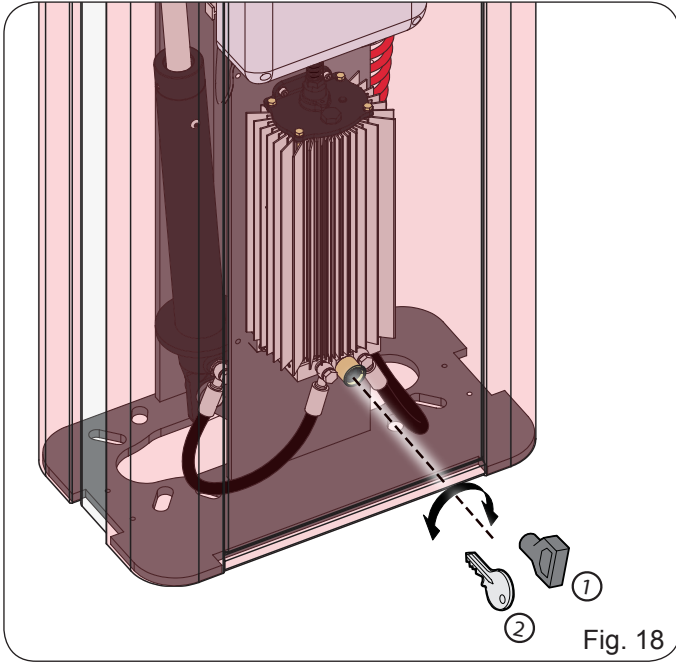

Fig. 18

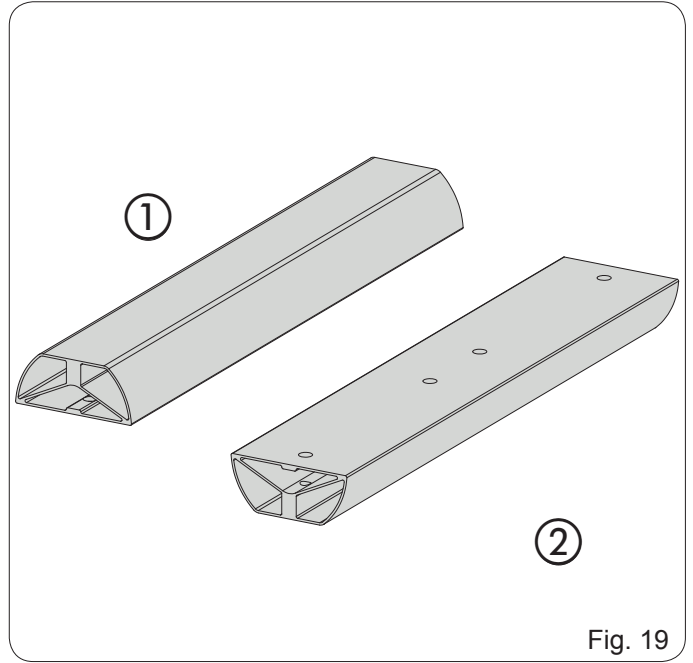
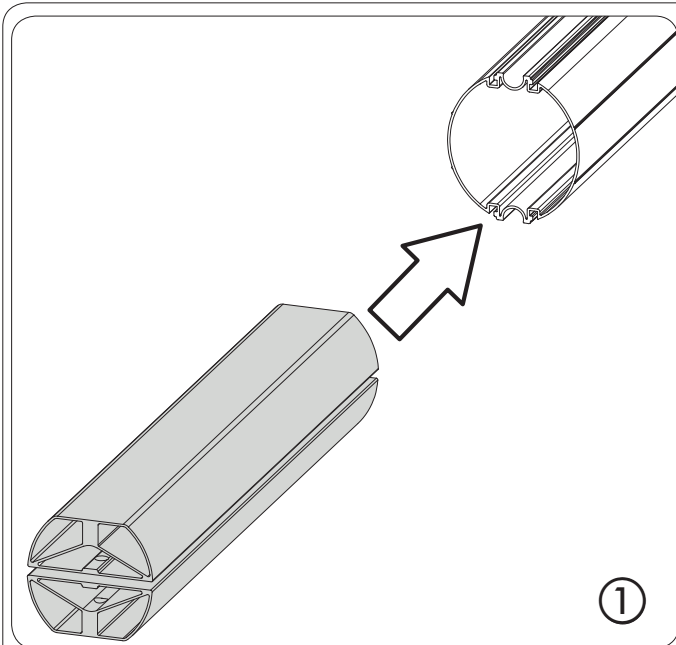
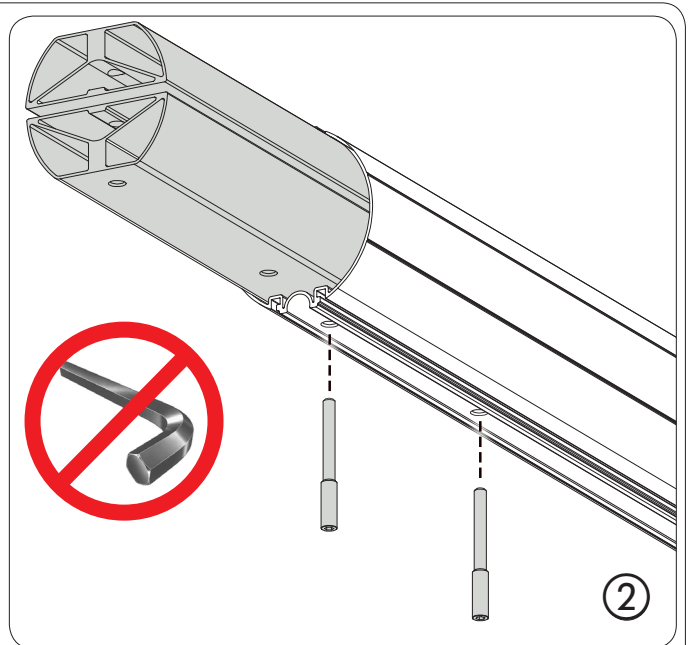

Fig. 19



1



2

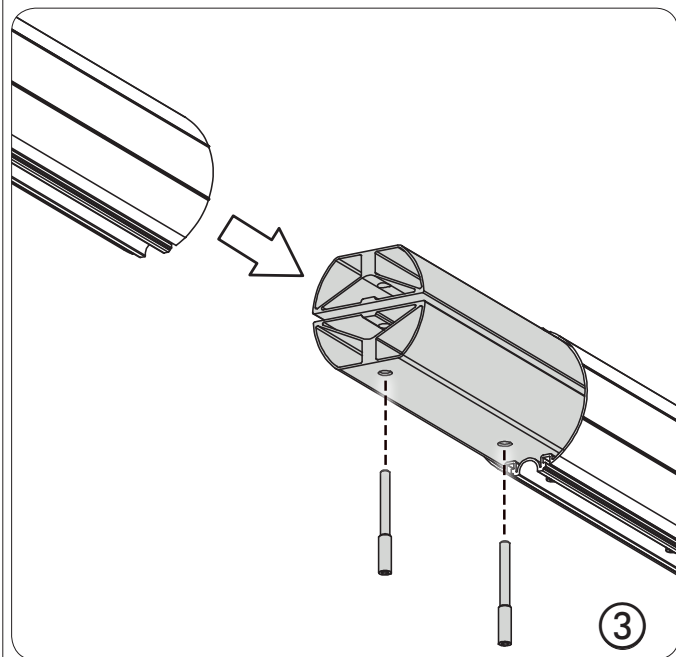

3

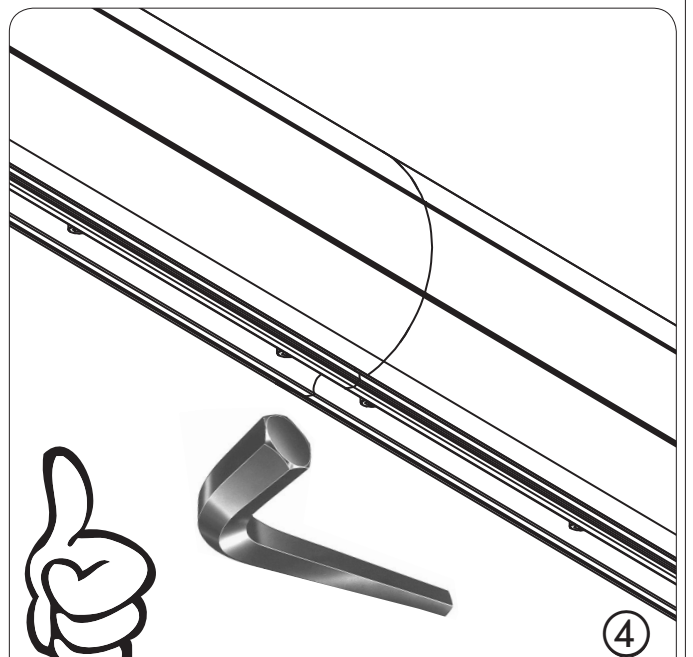

4

Fig. 20



Fig. 21

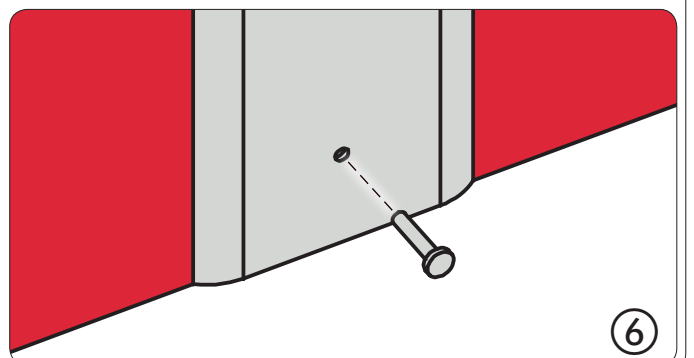
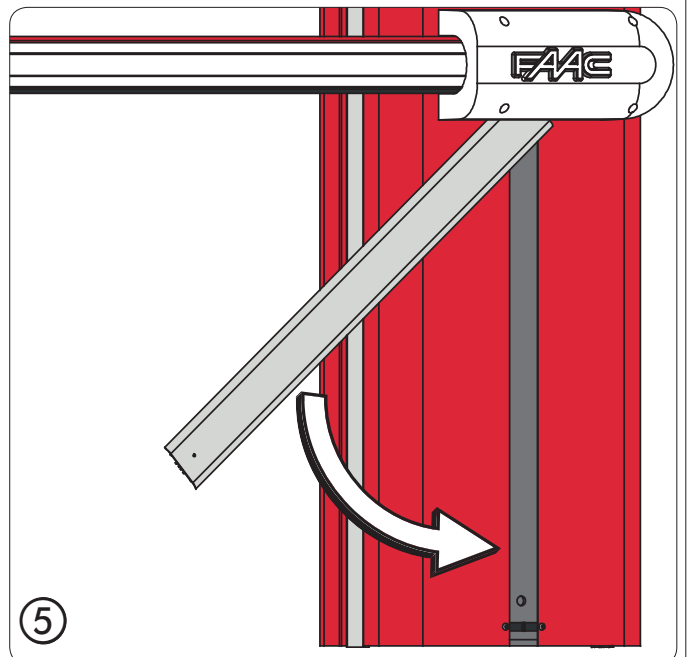
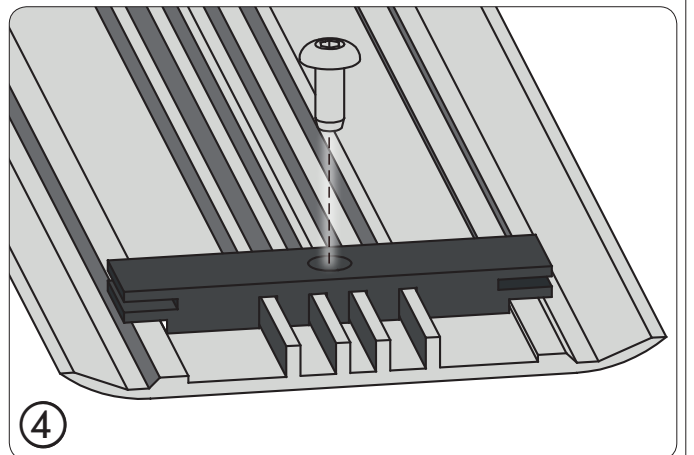
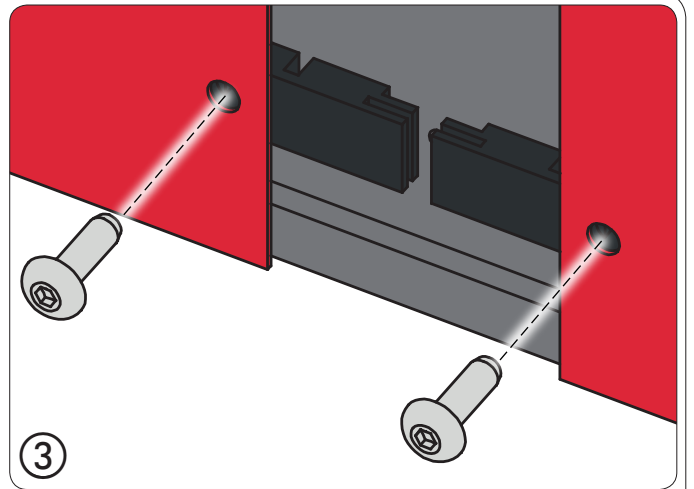
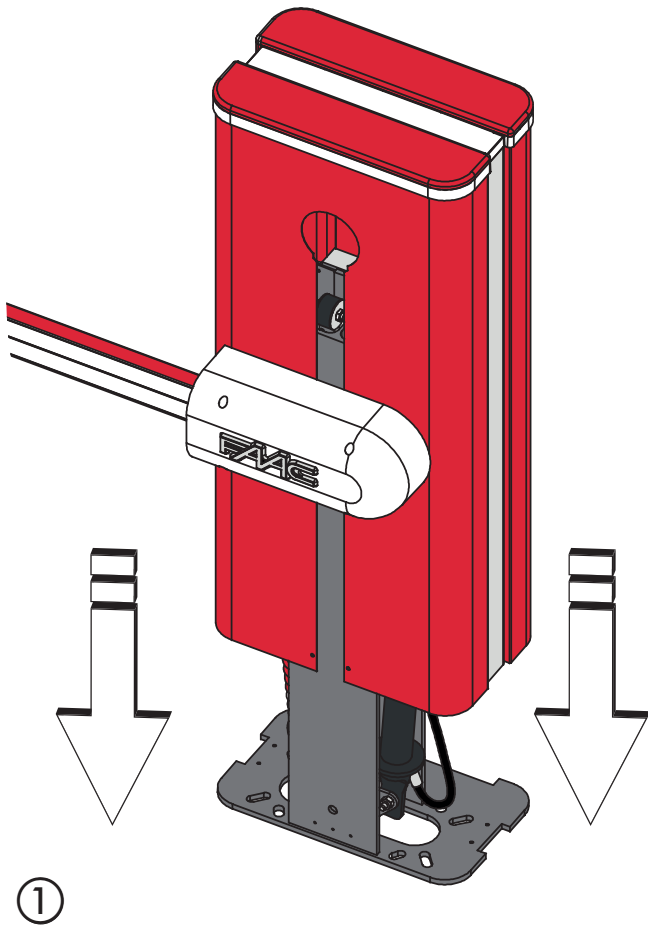



Fig. 22

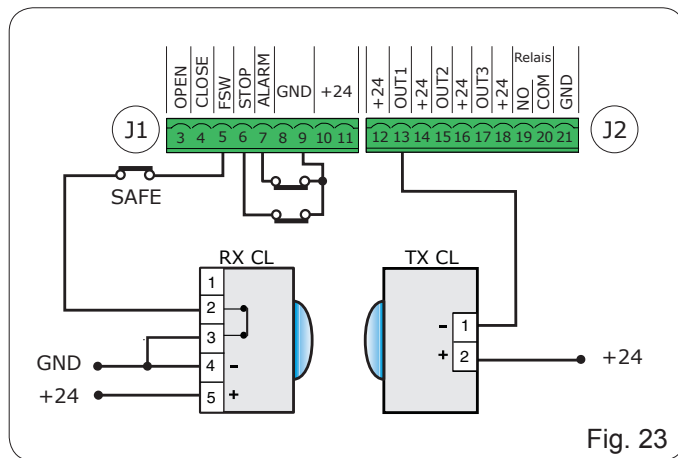
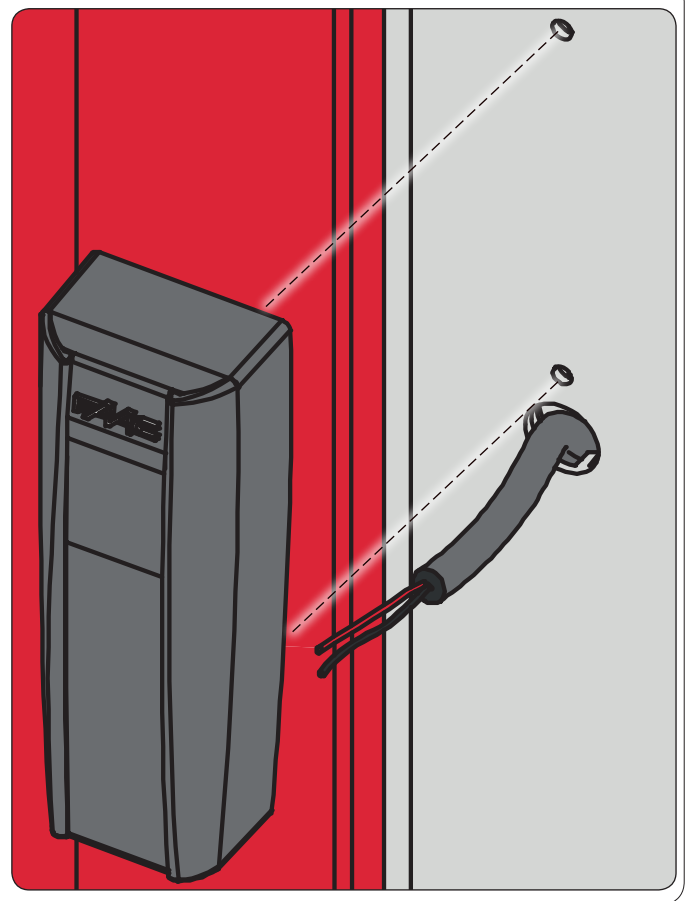
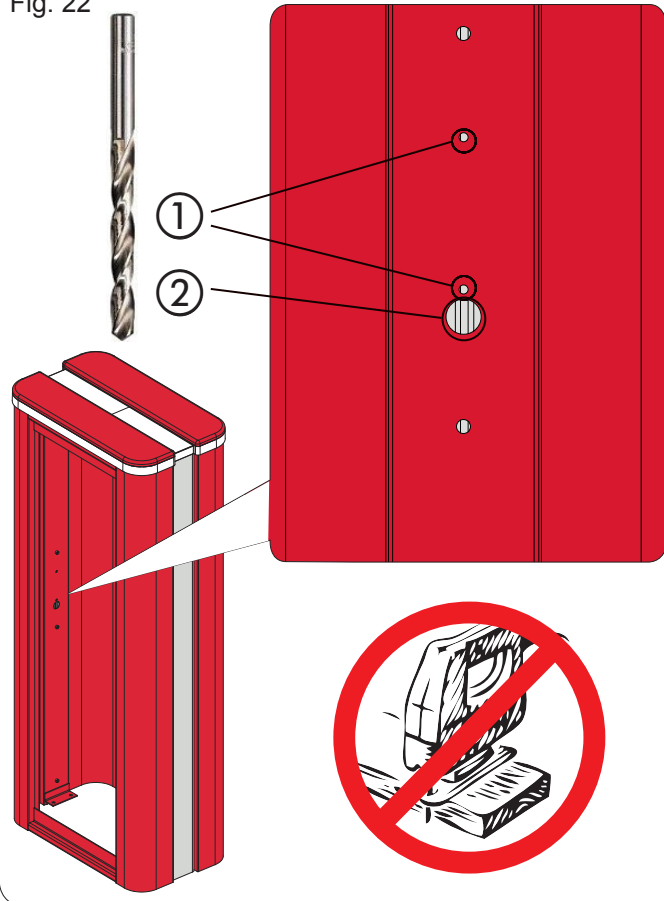

Fig. 23

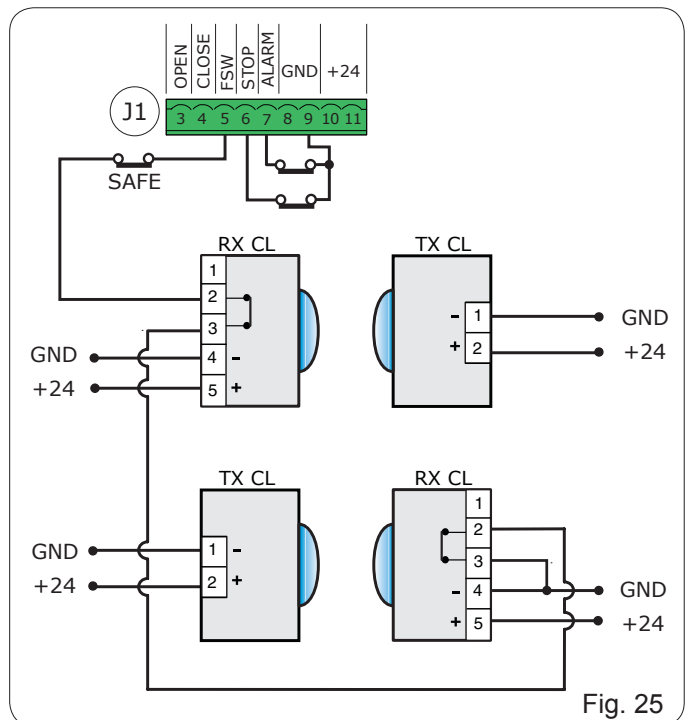

Fig. 25

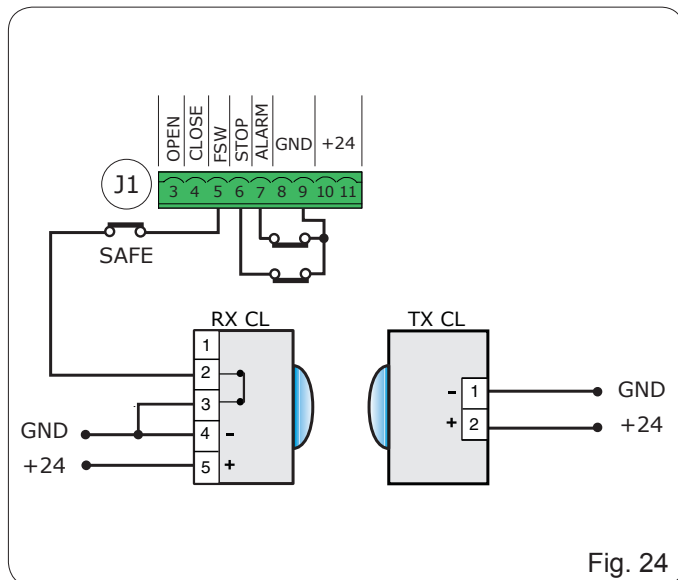

Fig. 24

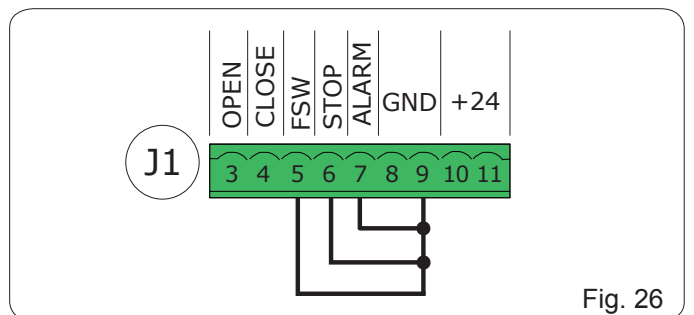

Fig. 26

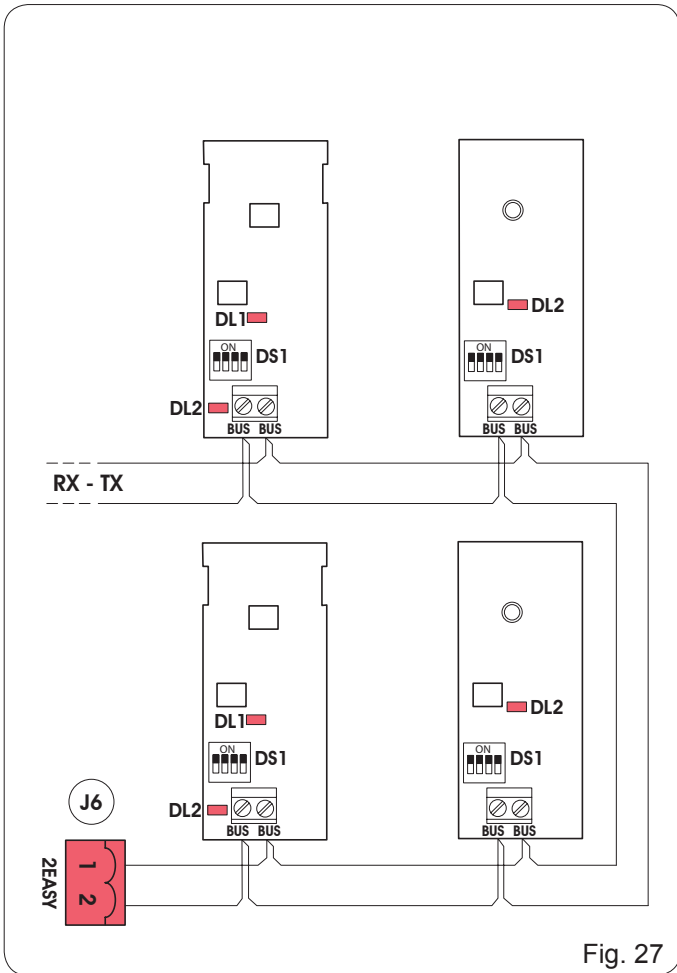

Fig. 27

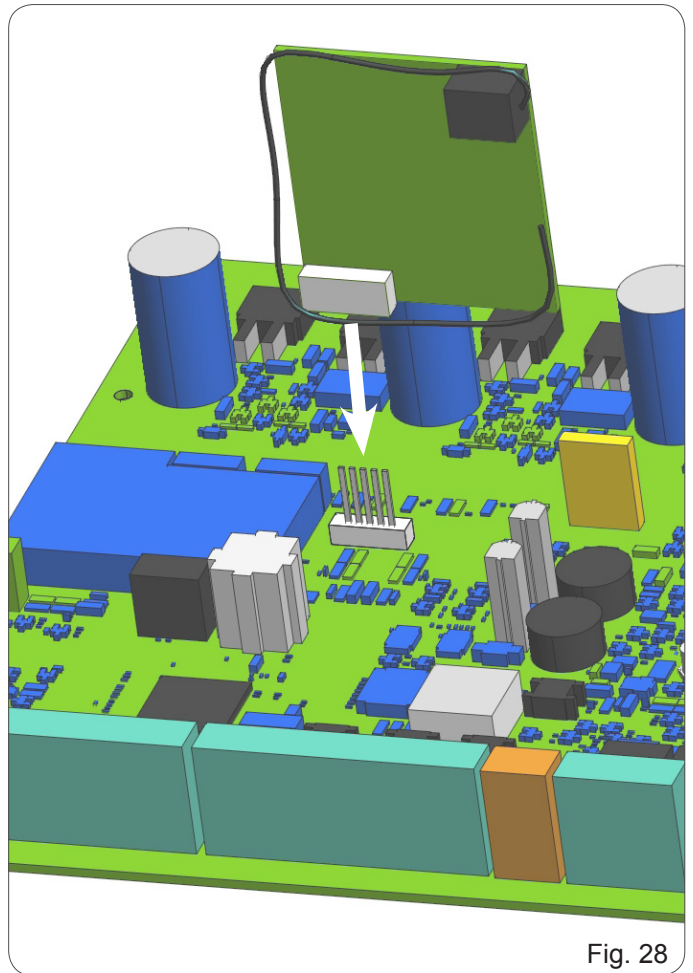

Fig. 28



Fig. 29

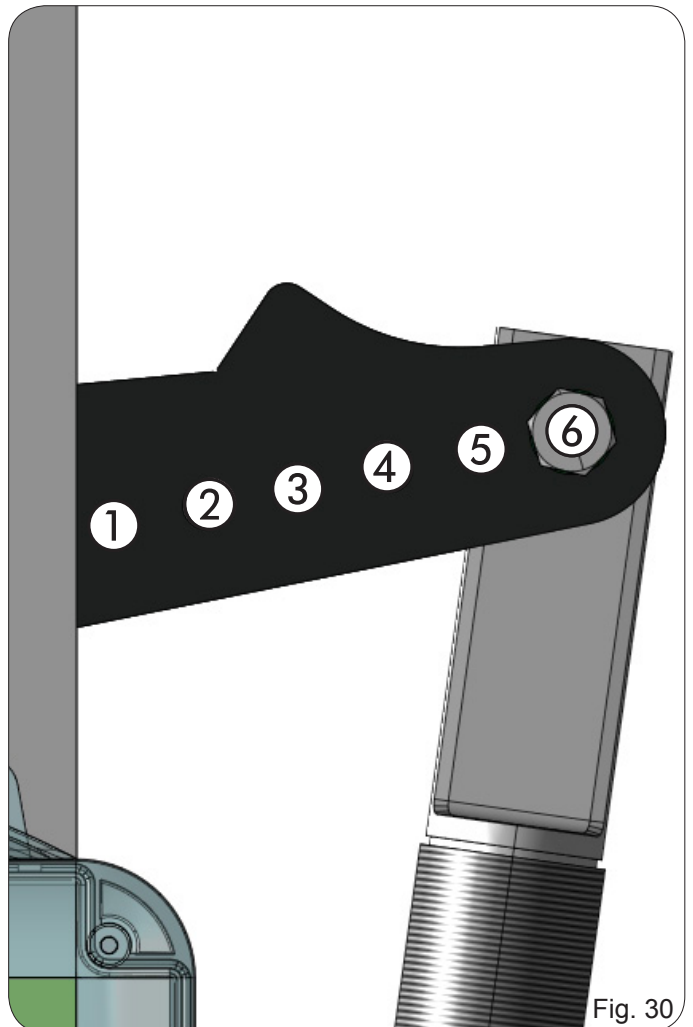
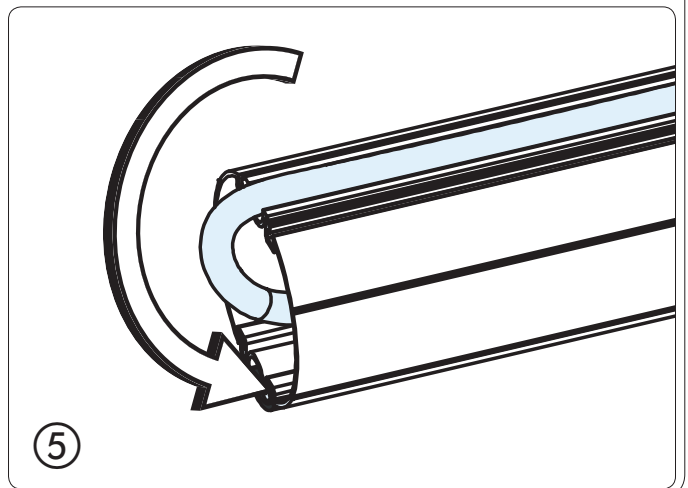
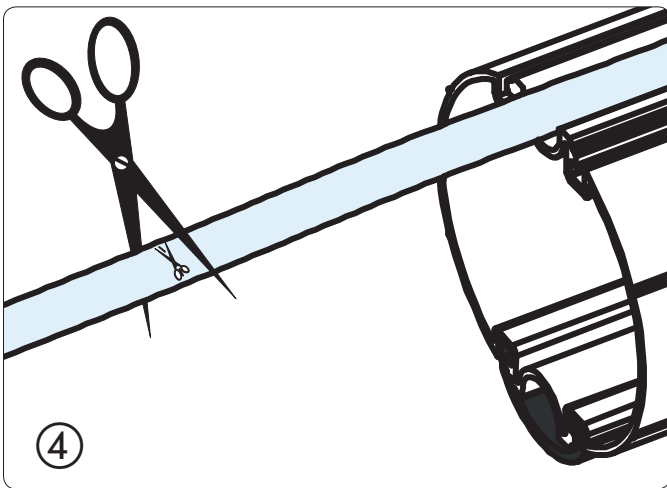
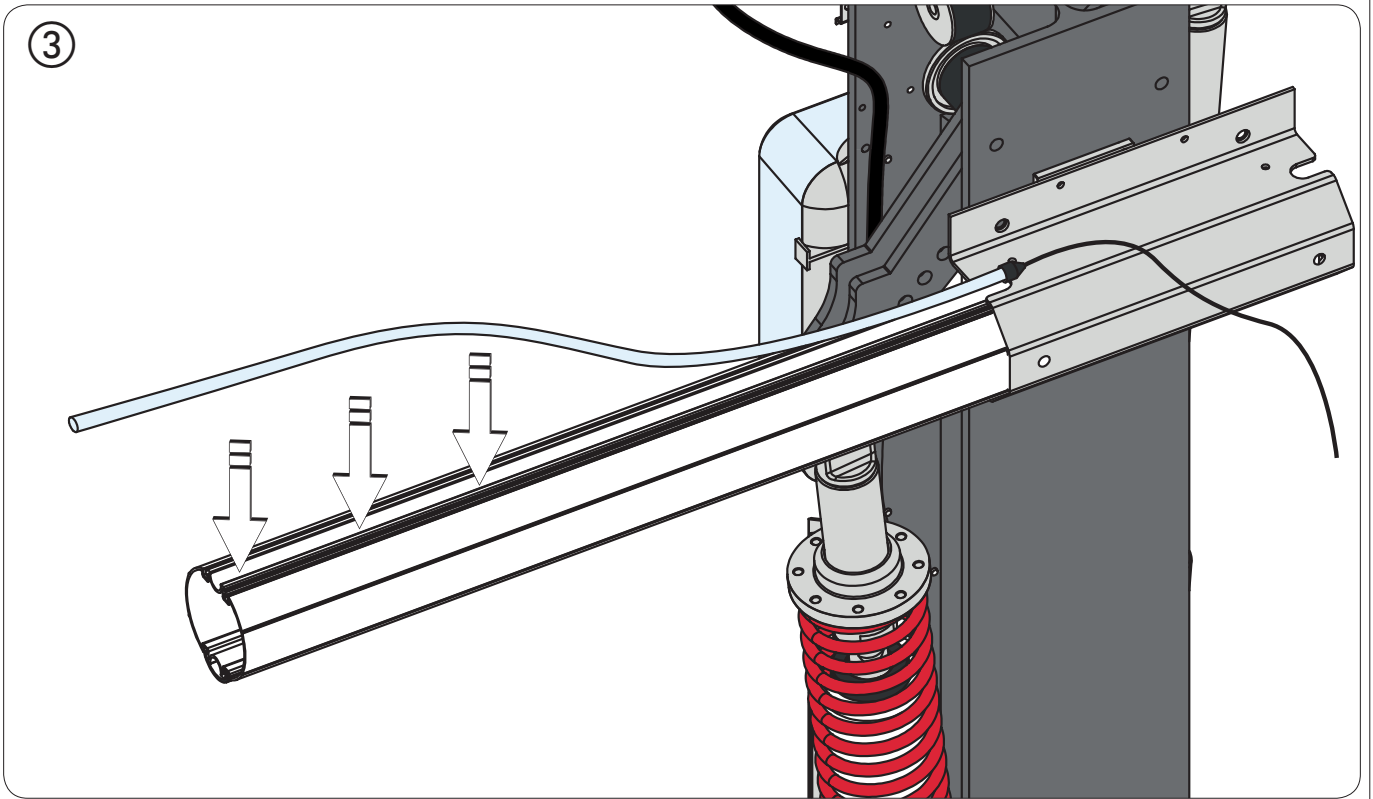
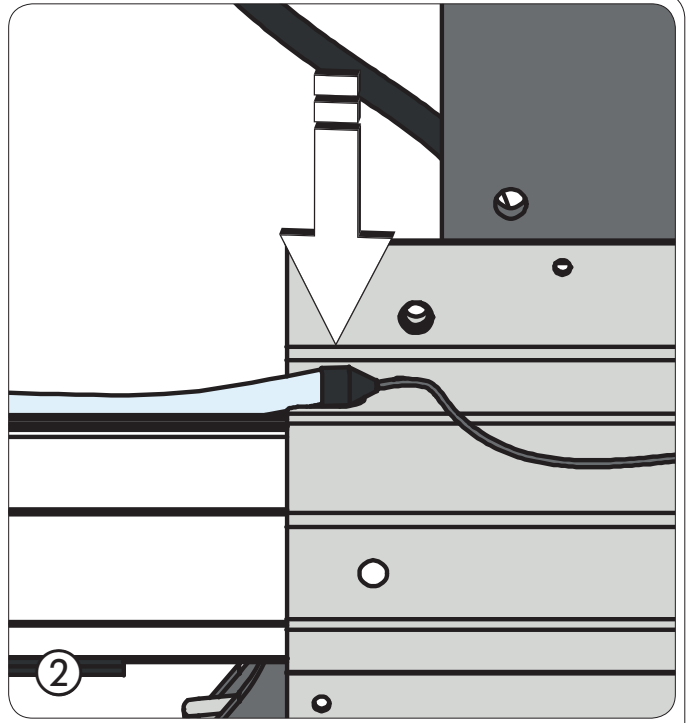
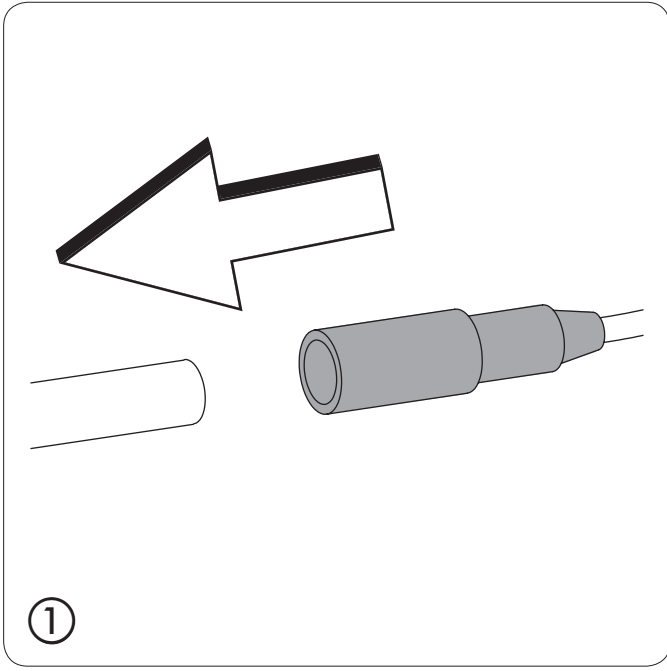

Fig. 30



Fig. 31



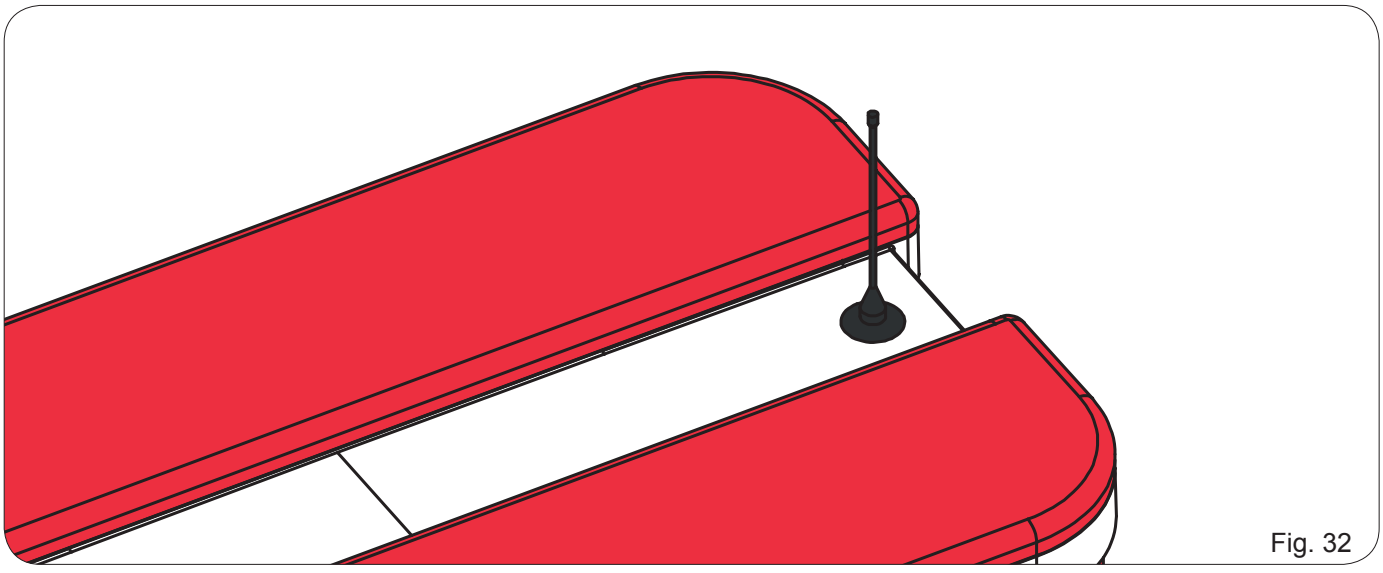
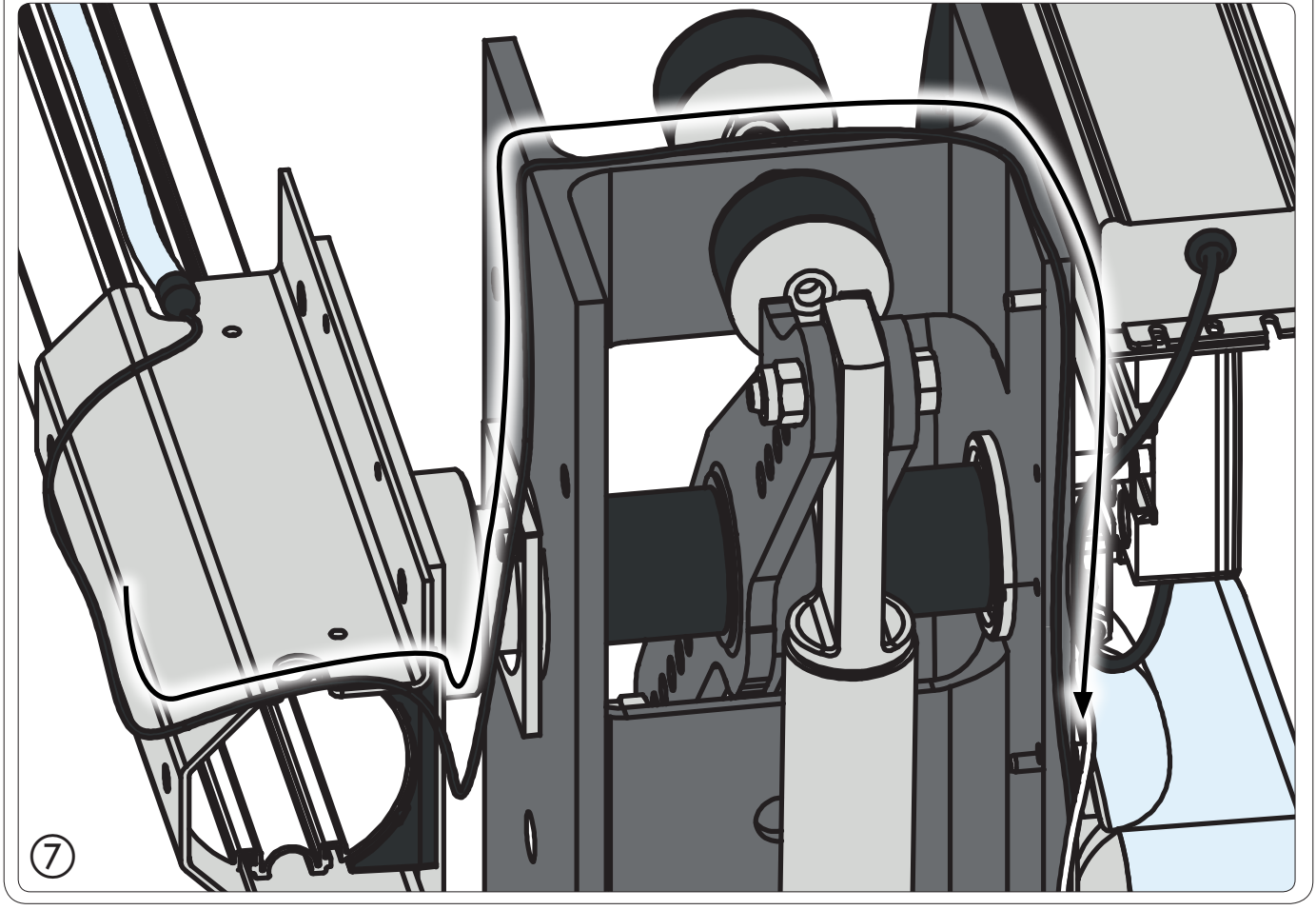
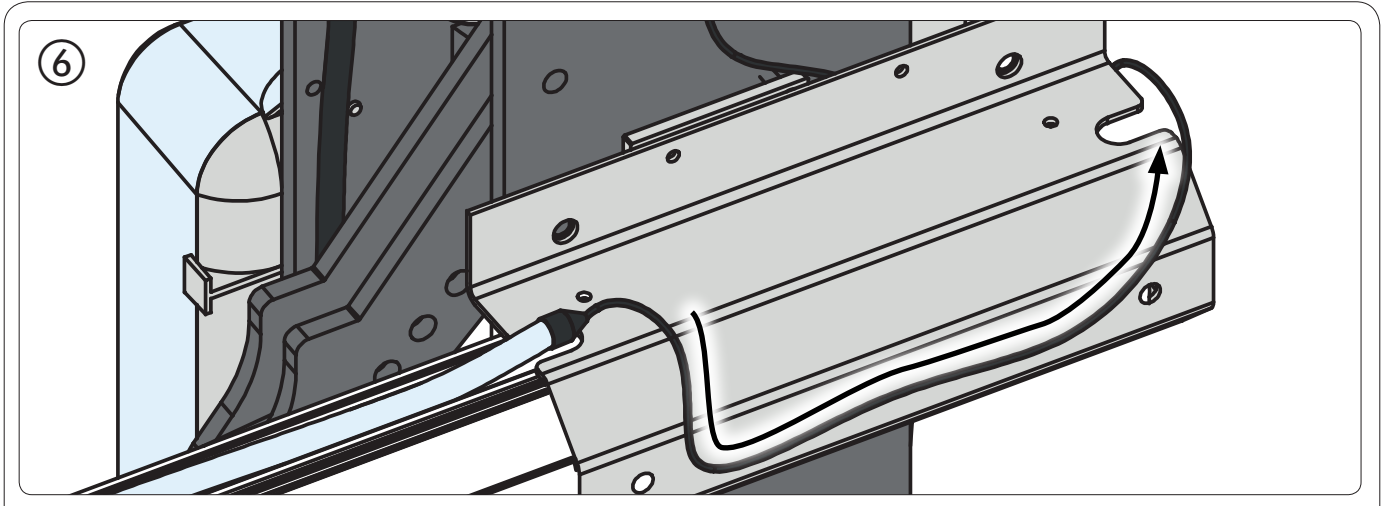
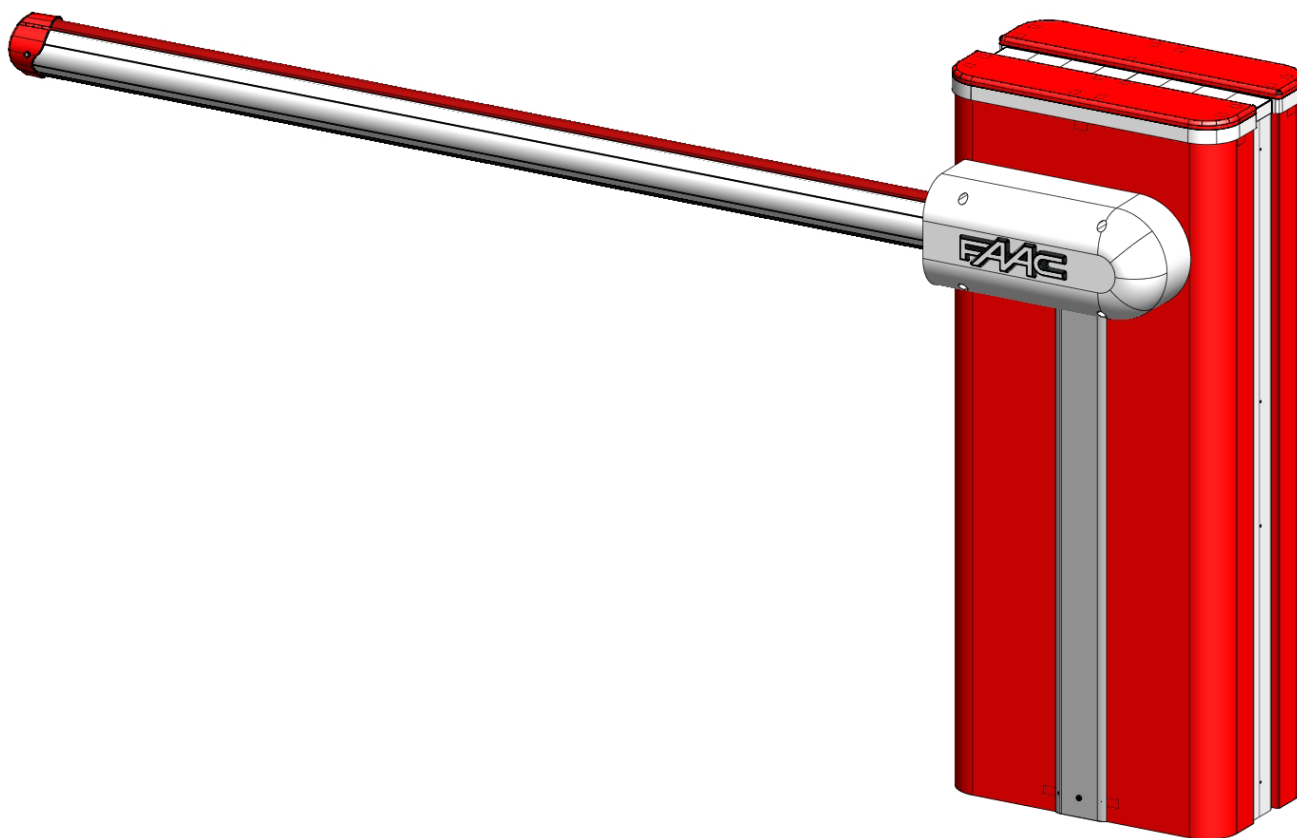

Fig. 32

B680H



Guida per l'utente
User's guide
Instructions pour l'utilisateur
Anleitungen für den Benutzer
Guía para el usuario
Gebruikersgids

FAAC

MANUALE UTENTE AUTOMAZIONE B680H

1. AVVERTENZE

- 1) FAAC declina qualsiasi responsabilità derivata dall'uso improprio o diverso da quello per cui l'automatismo è destinato.
- 2) FAAC non è responsabile dell'inosservanza della Buona Tecnica nella costruzione delle chiusure da motorizzare, nonché delle deformazioni che dovessero intervenire nell'utilizzo.
- 3) L'automazione dispone di una sicurezza intrinseca antischiacciamento costituita da un controllo di coppia.
- 4) FAAC declina ogni responsabilità ai fini della sicurezza e del buon funzionamento dell'automazione, in caso vengano utilizzati componenti dell'impianto non di produzione FAAC.
- 5) Per la manutenzione utilizzare esclusivamente parti originali FAAC.
- 6) Non eseguire alcuna modifica sui componenti facenti parte del sistema d'automazione.
- 7) L'installatore deve fornire tutte le informazioni relative al funzionamento manuale del sistema in caso di emergenza e consegnare all'Utente utilizzatore dell'impianto il libretto d'avvertenze allegato al prodotto.
- 8) Non permettere ai bambini o persone di sostare nelle vicinanze del prodotto durante il funzionamento.
- 9) Tenere fuori dalla portata dei bambini radiocomandi o qualsiasi altro datore di impulso, per evitare che l'automazione possa essere azionata involontariamente.
- 10) Il transito deve avvenire solo ad automazione ferma.
- 11) L'Utente utilizzatore deve astenersi da qualsiasi tentativo di riparazione o d'intervento diretto e rivolgersi solo a personale qualificato.
- 12) Manutenzione: effettuare almeno semestralmente la verifica funzionale dell'impianto, con particolare attenzione all'efficienza dei dispositivi di sicurezza (compresa, ove previsto, la forza di spinta dell'operatore) e di sblocco.

2. DESCRIZIONE

L'automazione è costituita da una sbarra in alluminio bianca con adesivi rifrangenti, luci di segnalazione opzionali, un cofano di copertura ed un montante in acciaio. All'interno del cofano risiede l'operatore composto dal montante al quale sono fissati una centralina oleodinamica e due pistoni tuffanti che per mezzo di un bilancere provvedono alla rotazione della sbarra. Quest'ultima rimane in equilibrio grazie a una molla di bilanciamento assemblata su uno dei pistoni tuffanti. L'apparecchiatura elettronica di comando è anch'essa alloggiata sul montante all'interno di un contenitore, ed il tutto è protetto dal cofano esterno di copertura. Il sistema è dotato di sicurezza antischiacciamento elettronica regolabile, di un dispositivo che garantisce arresto e blocco della sbarra in qualsiasi posizione e di un comodo sblocco manuale da manovrare in caso di black-out o disservizio.

3. FUNZIONAMENTO MANUALE

Nel caso in cui sia necessario azionare manualmente la barriera a causa della mancanza di alimentazione elettrica o disservizio dell'automazione, è necessario agire sul dispositivo di sblocco tramite la chiave in dotazione.

La chiave di sblocco in dotazione può essere triangolare (Fig. 18 rif. ①) o personalizzata (Fig. 18 rif. ②) opzionale.

- Inserire la chiave di sblocco nella serratura e ruotare la chiave in **senso antiorario** fino a battuta, come in Fig. 18
- Effettuare manualmente la manovra di apertura o chiusura della sbarra.



Con asta sbloccata, il motore si potrebbe attivare per circa 3 secondi. Tale funzionamento è normale e previsto dal parametro Hold Close / Hold Open

4. RIPRISTINO DEL FUNZIONAMENTO NORMALE

Per evitare che un impulso involontario possa azionare la barriera durante la manovra, prima di inserire il sistema di blocco, togliere alimentazione all'impianto.

chiave di sblocco triangolare (standard):

- ruotare la chiave in **senso orario** fino all'arresto ed estrarla (Fig. 18 rif. ①).

chiave di sblocco personalizzata (opzionale):

- ruotare la chiave in **senso orario** fino all'arresto ed estrarla. (Fig. 18 rif. ②).

B680H AUTOMATION USER MANUAL

1. WARNINGS

- 1) FAAC declines all liability caused by improper use or use other than that for which the automated system was intended.
- 2) FAAC is not responsible for failure to observe Good Technique in the construction of the closing elements to be motorised, or for any deformation that may occur during use.
- 3) The automated system features a built-in anti-crushing safety device consisting of a torque control.
- 4) FAAC declines all liability as concerns safety and efficient operation of the automated system, if system components not produced by FAAC are used.
- 5) For maintenance, strictly use original parts by FAAC.
- 6) Do not in any way modify the components of the automated system
- 7) The installer shall supply all information concerning manual operation of the system in case of an emergency, and shall hand over to the User the leaflet supplied with the product.
- 8) Do not allow children or adults to stay near the product while it is operating.
- 9) Keep radio controls or other pulse generators away from children, to prevent the automated system from being activated involuntarily.
- 10) Transiting is permitted only when the automated system is stationary.
- 11) The User must not attempt any kind of repair or direct action whatever and contact qualified personnel only.
- 12) Maintenance: check at least every 6 months the efficiency of the system, particularly the efficiency of the safety devices (including, where foreseen, the operator thrust force) and of the release devices.

2. DESCRIPTION

The automated system consists of a white aluminium beam with reflectors, optional signalling lights, a covering compartment and steel upright profile. Inside the compartment there is an operator consisting of the upright profile with a hydraulic unit and two plunging pistons fixed to it, which, by means of a rocker arm, rotate the beam. The latter remains balanced thanks to a balance spring fitted on one of the two plunging pistons. The electronic control equipment is also housed on the upright, inside a compartment, and the whole is protected by the external covering compartment.

The system features an adjustable electronic anti-crushing safety, a device that guarantees stopping and locking of the beam in any position, and a convenient manual release for use in case of black-out or inefficiency.

3. MANUAL OPERATION

Should manual operation of the barrier be required due to electrical power cut-offs or automated system inefficiency, use the release device with the provided key.

The provided unlocking key is either triangular (Fig. 18 ref. a) or customised (Fig. 18 ref. b) optional).

- Insert the unlocking key in the lock and turn the key **anticlockwise** until it clicks into place, as shown in Fig. 18
- Open or close the beam manually.



With the bar released, the motor may start for approximately 3 seconds. This is normal and determined by the parameter Hold Close / Hold Open

4. RESTORING NORMAL OPERATION

To avoid an accidental pulse opening the barrier during this operation, before activating the locking system, cut off all power to the system.

triangular unlocking key (standard):

- turn the key **clockwise** until it stops and then remove it (Fig. 18 ref. ①).

customised unlocking key (optional):

- turn the key **clockwise** until it stops and then remove it (Fig. 18 ref. ②).

MANUEL DE L'UTILISATEUR AUTOMATISME B680H

1. PRECAUTIONS

- 1) FAAC décline toute responsabilité qui dériverait d'usage impropre ou différent de celui auquel l'automatisme est destiné.
- 2) FAAC n'est pas responsable du non-respect de la Bonne Technique dans la construction des fermetures à motoriser, ni des déformations qui pourraient intervenir lors de l'utilisation.
- 3) L'automatisme dispose d'une sécurité intrinsèque anti-écrasement constituée par un contrôle de couple.
- 4) FAAC décline toute responsabilité quant à la sécurité et au bon fonctionnement de l'automatisme si les composants utilisés dans l'installation n'appartiennent pas à la production FAAC.
- 5) Utiliser exclusivement, pour l'entretien, des pièces FAAC originales.
- 6) Ne jamais modifier les composants faisant partie du système d'automatisme.
- 7) L'installateur doit fournir toutes les informations relatives au fonctionnement manuel du système en cas d'urgence et remettre à l'Usager qui utilise l'installation les « Instructions pour l'Usager » fournies avec le produit.
- 8) Interdire aux enfants ou aux tiers de stationner près du produit durant le fonctionnement.
- 9) Éloigner de la portée des enfants les radiocommandes ou tout autre générateur d'impulsions, pour éviter tout actionnement involontaire de l'automatisme.
- 10) Le transit n'est possible que lorsque l'automatisme est à l'arrêt.
- 11) L'Usager qui utilise l'installation doit éviter toute tentative de réparation ou d'intervention directe et s'adresser uniquement à un personnel qualifié.
- 12) Entretien : procéder tous les six mois au moins à la vérification fonctionnelle de l'installation, en faisant particulièrement attention à l'efficacité des dispositifs de sécurité (y compris, lorsqu'elle est prévue, la force de poussée de l'opérateur) et de déverrouillage.

2. DESCRIPTION

L'automatisme est constitué par une lisse blanche en aluminium avec des catadioptrés réfléchissants, des feux de signalisation en option, un coffre de protection et un montant en acier. Le coffre contient l'opérateur constitué par le montant auquel sont fixés une centrale oléodynamique et deux pistons plongeurs qui, par l'intermédiaire d'un compensateur, effectuent la rotation de la lisse. Celle-ci reste en équilibre, grâce à un ressort d'équilibrage assemblé sur un des pistons plongeurs. L'armoire électronique de manœuvre est, elle aussi, logée dans le montant, à l'intérieur d'un boîtier ; le tout est protégé par le coffre externe de protection.

Le système est équipé d'une sécurité anti-écrasement électronique, réglable, d'un dispositif qui garantit l'arrêt et le blocage de la lisse, dans toute position et d'un déverrouillage manuel pratique à manœuvrer en cas de coupure de courant ou de dysfonctionnement.

3. FONCTIONNEMENT MANUEL

S'il est nécessaire d'actionner manuellement la barrière, à cause d'une coupure de courant ou d'un dysfonctionnement de l'automatisme, agir sur le dispositif de déverrouillage avec la clé fournie.

La clé de déverrouillage fournie peut être triangulaire (Fig. 18, réf. ①) ou personnalisée (Fig. 18, réf. ② en option).

- Introduire la clé de déverrouillage dans la serrure et tourner la clé à fond en **sens inverse horaire** d'après la Fig. 18.
- Effectuer manuellement la manœuvre d'ouverture ou de fermeture de la lisse.



Lorsque la lisse est déverrouillée, le moteur peut s'activer pendant 3 secondes. Ce fonctionnement est normal et prévu par le paramètre Hold Close / Hold Open.

4. RÉTABLISSEMENT DU FONCTIONNEMENT NORMAL

Pour éviter qu'une impulsion involontaire n'actionne la barrière durant la manœuvre, couper le courant sur l'installation avant d'activer le système de blocage.

clé de déverrouillage triangulaire (standard) :

- tourner la clé **en sens horaire** jusqu'à l'arrêt et l'extraire (Fig. 18, réf. ①).

clé de déverrouillage personnalisée (en option) :

- tourner la clé **en sens horaire** jusqu'au point où l'extraction est possible. (Fig. 18, réf. ②).

ANWEISUNGEN FÜR DEN BENUTZER AUTOMATION B680H

1. HINWEISE

- 1) Die Firma FAAC lehnt jede Haftung für Schäden ab, die durch unsachgemäßen oder nicht bestimmungsgemäßen Gebrauch der Automatik verursacht werden.
- 2) Die Firma FAAC übernimmt keine Haftung im Falle von nicht fachgerechten Ausführungen bei der Herstellung der anzutreibenden Schließvorrichtungen sowie bei Deformationen, die eventuell beim Betrieb entstehen.
- 3) Die Automation verfügt über ein integriertes Quetschschutzsystem, das aus einer Drehmomentkontrolle besteht. Die Auslöseschwelle muss jedoch nach den Vorschriften laut Punkt 10 überprüft werden.
- 4) Die Firma FAAC lehnt jede Haftung hinsichtlich der Sicherheit und des störungsfreien Betriebs der Automation ab, soweit Komponenten auf der Anlage eingesetzt werden, die nicht im Hause FAAC hergestellt wurden.
- 5) Bei der Instandhaltung sollten ausschließlich Originalteile der Firma FAAC verwendet werden.
- 6) Auf den Komponenten, die Teil des Automationssystems sind, sollten keine Änderungen vorgenommen werden.
- 7) Der Installateur sollte alle Informationen hinsichtlich des manuellen Betriebs des Systems in Notfällen liefern und dem Anwender der Anlage die Anleitung übergeben, die dem Produkt beigelegt ist.
- 8) Weder Kinder noch Erwachsene sollten sich während des Betriebs in der unmittelbaren Nähe der Automation aufhalten.
- 9) Die Funksteuerungen und alle anderen Impulsgeber sollten außerhalb der Reichweite von Kindern aufbewahrt werden, um ein versehentliches Aktivieren der Automation zu vermeiden.
- 10) Der Durchgang/die Durchfahrt darf nur bei stillgesetzter Automation erfolgen.
- 11) Der Anwender sollte keinerlei Reparaturen oder direkte Eingriffe auf der Automation ausführen, sondern sich hierfür ausschließlich an qualifiziertes Fachpersonal wenden.
- 12) Wartung: mindestens halbjährlich die Anlagefunktionsfähigkeit, besonders die Funktionsfähigkeit der Sicherheitsvorrichtungen (einschl. falls vorgesehen, die Schubkraft des Antriebs) und der Entriegelungsvorrichtungen überprüfen..

2. Beschreibung

Die Automation besteht aus einem weißen Aluminium-Balken mit Rückstrahlern, optionalen Leuchtsignalen, einer Abdeckung und einem Stahlpfosten. In der Abdeckung befindet sich der Antrieb, bestehend aus dem Pfosten, an dem ein Hydraulikaggregat sowie zwei Tauchkolben angebracht sind, die über eine Kippvorrichtung die Drehbewegung des Balkens bewirken. Eine auf einem der Tauchkolben montierte Ausgleichsfeder sorgt für die Beibehaltung des Gleichgewichts des Balkens. Das elektronische Steuergerät ist ebenfalls am Pfosten in einem Gehäuse untergebracht. Pfosten und Gehäuse werden durch die externe Abdeckung geschützt. Das System ist mit einem verstellbaren elektronischen Quetschschutz ausgerüstet sowie mit einer Vorrichtung, die Stopp und Verriegelung des Balkens in jeder beliebigen Position gewährleistet, und mit einer praktischen manuellen Entriegelungsvorrichtung, die bei Stromausfall oder Betriebsstörungen bedient werden kann.

3. MANUELLER BETRIEB

Sollte es aufgrund von Stromausfall oder Betriebsstörungen der Automation erforderlich sein, die Schranke von Hand zu betätigen, ist die Entriegelungsvorrichtung mit dem ihm Lieferumfang enthaltenen Schlüssel zu entriegeln.

Der mitgelieferte Entriegelungsschlüssel kann dreieckig (Abb. 18 Bez. ①) oder individuell gestaltet sein (Abb. 18 Bez. ② – optional).

- Den Entriegelungsschlüssel in das Schloss einstecken und **gegen den Uhrzeigersinn** bis zum Anschlag drehen (siehe Abb. 18).
- Den Balken von Hand öffnen oder schließen.



Bei entriegelter Stange könnte der Motor für zirka 3 Sekunden anlaufen. Dies ist normal und über den Parameter Hold Close/Hold Open festgelegt.

4. WIEDERHERSTELLUNG DES NORMALBETRIEBS

Um zu vermeiden, dass ein ungewollter Impuls die Schranke während der Bewegung betätigen kann, ist vor Einsetzen des Verriegelungssystems die Stromzufuhr zur Anlage zu unterbrechen.

Dreieckiger Entriegelungsschlüssel (Standard):

- Den Schlüssel bis zum Anschlag **im Uhrzeigersinn** drehen und abziehen (Abb. 18 Bez. ①).

Individueller Entriegelungsschlüssel (optional):

- Den Schlüssel bis zum Anschlag **im Uhrzeigersinn** so weit drehen, bis er abgezogen werden kann (Abb. 18 Bez. ②).

MANUAL PARA EL USUARIO AUTOMATISMO B680H

1. ADVERTENCIAS

- 1) FAAC declina cualquier responsabilidad derivada de un uso impropio o diverso del previsto.
- 2) FAAC no es responsable del incumplimiento de las buenas técnicas de fabricación de los cierres que se han de motorizar, así como de las deformaciones que pudieran intervenir en la utilización.
- 3) El automatismo dispone de un dispositivo de seguridad intrínseco antiplastamiento formado por un control de par.
- 4) FAAC declina toda responsabilidad relativa a la seguridad y al buen funcionamiento del automatismo si se utilizan componentes de la instalación que no sean de producción FAAC.
- 5) Para el mantenimiento utilicen exclusivamente piezas originales FAAC.
- 6) No efectúen ninguna modificación en los componentes que forman parte del sistema de automatización.
- 7) El instalador debe proporcionar todas las informaciones relativas al funcionamiento del sistema en caso de emergencia y entregar al usuario del equipo el manual de advertencias que se adjunta al producto.
- 8) No permitan que niños o personas se detengan en proximidad del producto durante su funcionamiento.
- 9) Mantengan lejos del alcance los niños los radiomandos o cualquier otro emisor de impulso, para evitar que el automatismo pueda ser accionado involuntariamente.
- 10) Sólo puede transitarse con el automatismo parado.
- 11) El usuario no debe por ningún motivo intentar reparar o modificar el producto, debe siempre dirigirse a personal cualificado.
- 12) Mantenimiento: compruebe por lo menos semestralmente que el equipo funcione correctamente, prestando especial atención a la eficiencia de los dispositivos de seguridad (incluida, donde estuviera previsto, la fuerza de empuje del operador) y de desbloqueo.

2. DESCRIPCIÓN

El automatismo está formado por una barra de aluminio blanca con catadióptricos reflectantes, luces de señalización opcionales, un cárter y un montante de acero. En el interior del cárter reside el operador formado por el montante al cual están fijados una centralita oleodinámica y dos pistones buzos que, por medio de un balancín, efectúan la rotación de la barra. Esta última permanece en equilibrio gracias a un muelle de equilibrado ensamblado en uno de los émbolos buzos. El equipo electrónico de mando también está alojado en el montante, dentro de un contenedor, y todo el conjunto está protegido por el cárter externo. El sistema está provisto de un dispositivo de seguridad antiplastamiento electrónico regulable, de un dispositivo que garantiza la parada y el bloqueo de la barra en cualquier posición, y de un cómodo desbloqueo manual que permite maniobrar la barra en caso de falta de alimentación eléctrica o de avería.

3. FUNCIONAMIENTO MANUAL

Si fuera necesario mover la barrera manualmente, por ejemplo por un corte de corriente o un fallo del automatismo, es necesario manipular el dispositivo de desbloqueo por medio de la llave entregada en dotación.

La llave de desbloqueo entregada en dotación puede ser triangular (Fig. 18, ref. ①) o personalizada (Fig. 18 ref. ② opcional).

- Inserte la llave de desbloqueo en la cerradura y gire la llave en sentido antihorario hasta el tope, como en la Fig. 18
- Efectúe manualmente la maniobra de apertura o cierre de la barra.



Con la barra bloqueada el motor se podría activar durante unos 3 segundos. Dicho funcionamiento es normal y está previsto por el parámetro Hold Close / Hold Open

4. RESTABLECIMIENTO DEL FUNCIONAMIENTO NORMAL

Para evitar que un impulso involuntario pueda accionar la barrera durante la maniobra, antes de activar el sistema de bloqueo hay que quitar la alimentación al equipo.

llave de desbloqueo triangular (estándar):

- gire la llave en sentido horario hasta el tope y extráigala (fig. 18 ref. ①).

llave de desbloqueo personalizada (opcional):

- gire la llave en sentido horario hasta el punto en el que se pueda extraerla. (Fig. 18, ref. ②).

GEBRUIKERSHANDLEIDING AUTOMATISCH SYSTEEM B680H

1. WAARSCHUWINGEN

- 1) FAAC aanvaardt geen enkele aansprakelijkheid voor schade die ontstaat uit oneigenlijk gebruik of ander gebruik dan waarvoor het automatische systeem is bedoeld.
- 2) FAAC is niet aansprakelijk als de regels der goede techniek niet in acht genomen zijn bij de bouw van het sluitwerk dat gemotoriseerd moet worden, noch voor vervormingen die zouden kunnen ontstaan bij het gebruik.
- 3) Het automatisch systeem heeft een intrinsieke beknellingsbeveiliging in de vorm van een koppelbegrenzer.
- 4) FAAC aanvaardt geen enkele aansprakelijkheid voor wat betreft de veiligheid en de goede werking van het automatische systeem, als er in de installatie gebruik gemaakt wordt van componenten die niet door FAAC zijn geproduceerd.
- 5) Gebruik voor het onderhoud uitsluitend originele FAAC-onderdelen.
- 6) Verricht geen wijzigingen op componenten die deel uitmaken van het automatische systeem.
- 7) De installateur dient alle informatie te verstrekken over de handbediening van het systeem in noodgevallen, en moet de gebruiker van de installatie het bij het product geleverde boekje met aanwijzingen overhandigen.
- 8) Sta het niet toe dat kinderen of volwassenen zich ophouden in de buurt van het product terwijl dit in werking is.
- 9) Houd radio-afstandsbedieningen of alle andere impulsgevers buiten het bereik van kinderen, om te voorkomen dat het automatische systeem onopzettelijk kan worden aangedreven.
- 10) Doorgang is alleen toegestaan wanneer het automatisch systeem stilstaat.
- 11) De gebruiker mag geen pogingen tot reparatie doen of directe ingrepen plegen, en dient zich uitsluitend te wenden tot gekwalificeerd personeel.
- 12) Onderhoud: de werking van de installatie dient minstens eenmaal per half jaar te worden gecontroleerd. Hierbij dient bijzondere aandacht te worden besteed aan de veiligheidsvoorzieningen (inclusief, waar voorzien, de duwkracht van de aandrijving) en de ontgrendelmechanismen.

2. BESCHRIJVING

Die Automation bestaat aus einem weißen Aluminium-Balken mit Het automatisch systeem bestaat uit een boom van wit aluminium met reflectoren, optionele signaleringslampjes, een behuizing en een stalen staander. In de behuizing zit de aandrijving, bestaande uit een staander waaraan een hydraulische besturingseenheid en twee pluinerzuigers zijn bevestigd die door middel van een tuimelaar de slagboom laten draaien. Laatstgenoemde blijft in balans dankzij een op een van de pluinerzuigers gemonteerde balansveer. In een houder in de staander zit ook de elektronische besturingsapparatuur, en dit alles wordt beschermd door de externe behuizing.

Het systeem is voorzien van een elektrische regelbare beknellingsbeveiliging, een voorziening die garandeert dat de slagboom in een willekeurige positie wordt gestopt en geblokkeerd, en een handige handbediende ontgrendeling die kan worden gebruikt in geval van een black-out of storing.

3. HANDBEDIENDE WERKING

Als de slagboom met de hand moet worden bediend omdat de stroom is uitgevallen of het automatisch systeem niet goed werkt, moet met behulp van de bijgeleverde sleutel de ontgrendeling worden gebruikt. De bijgeleverde ontgrendelings sleutel kan driehoekig (Fig.18 ref. ①) of gepersonaliseerd zijn (Fig.18 ref. ②, optioneel).

- Steek de ontgrendelings sleutel in het slot en draai hem tegen de wijzers **van de klok** in tot hij niet verder kan, zoals in Fig. 18
- Open of sluit de boom met de hand.



Met de arm ontgrendeld zou de motor ongeveer 3 seconden kunnen worden ingeschakeld. Dit is normaal en wordt geregeld door de parameter Hold Close / Hold Open

4. HERSTEL NORMALE WERKING

Om te voorkomen dat de slagboom tijdens de manoeuvre per ongeluk door een impuls wordt ingeschakeld, moet alvorens de vergrendeling in te schakelen de voeding naar de installatie worden uitgeschakeld.

driehoekige ontgrendelings sleutel (standaard):

- draai de sleutel **met de wijzers van de klok mee** tot hij niet verder kan, en trek hem eruit (Fig. 18 ref. ①).

gepersonaliseerde sleutel (optioneel):

- draai de sleutel **met de wijzers van de klok mee** tot hij niet verder kan, en trek hem eruit (Fig. 18 ref. ②).

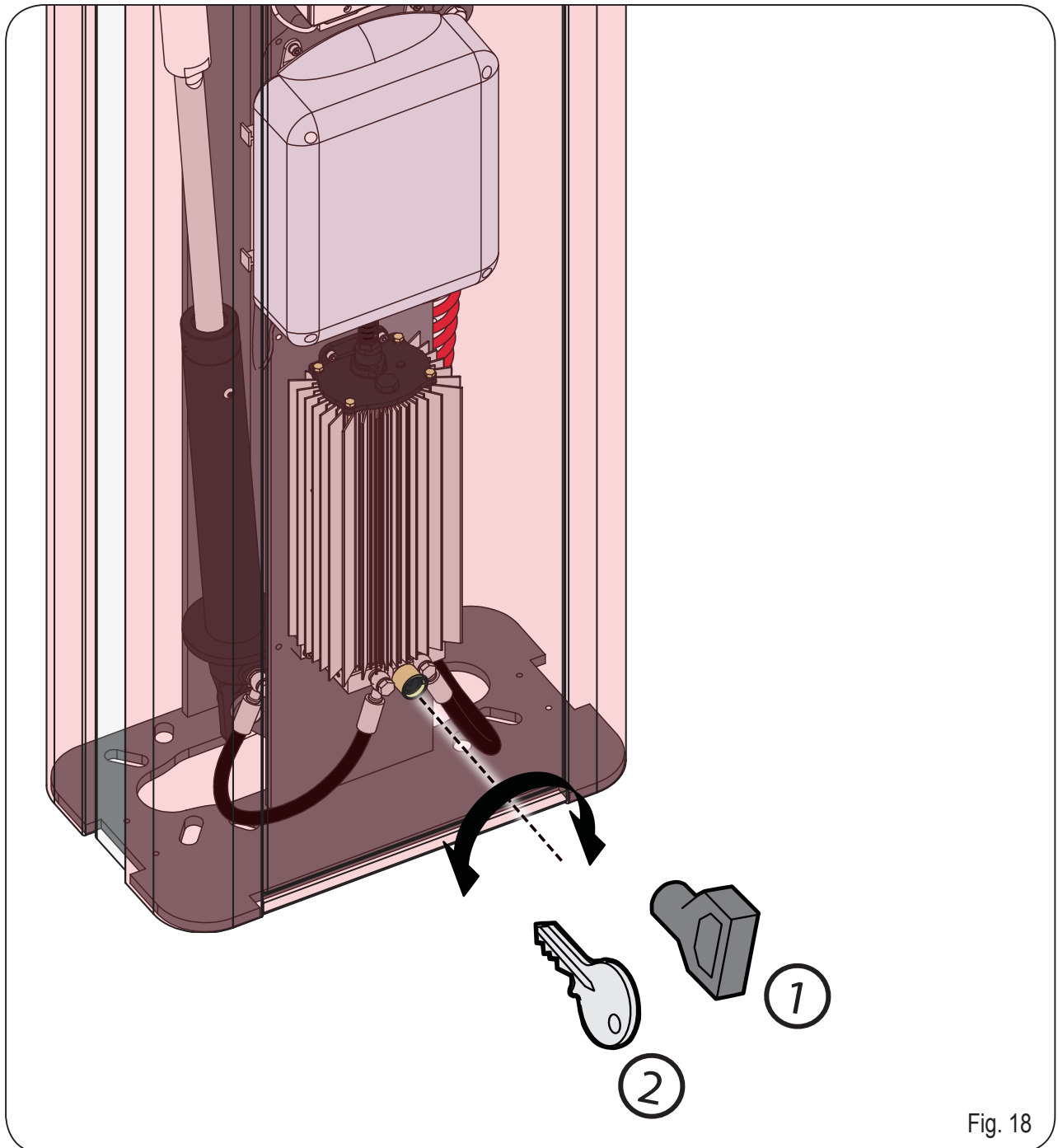

Fig. 18

SEDE - HEADQUARTERS

FAAC S.p.A.

Via Calari, 10
40069 Zola Predosa (BO) - ITALY
Tel. +39 051 61724 - Fax +39 051 758518
www.faac.it - www.faacgroup.com

ASSISTENZA IN ITALIA

SEDE

tel. +39 051 6172501
www.faac.it/ita/assistenza

MILANO

tel +39 02 66011163
filiale.milano@faacgroup.com

PADOVA

tel +39 049 8700541
filiale.padova@faacgroup.com

ROMA

tel +39 06 41206137
filiale.roma@faacgroup.com

TORINO

tel +39 011 6813997
filiale.torino@faacgroup.com

FIRENZE

tel. +39 055 301194
filiale.firenze@faacgroup.com

SUBSIDIARIES

AUSTRIA

FAAC GMBH
Salzburg, Austria
tel. +43 662 8533950
www.faac.at

FAAC TUBULAR MOTORS
tel. +49 30 56796645
faactm.info@faacgroup.com
www.faac.at

GERMANY

FAAC GMBH
Freilassing, Germany
tel. +49 8654 49810
www.faac.de

FAAC TUBULAR MOTORS
tel. +49 30 5679 6645
faactm.info@faacgroup.com
www.faac.de

BENELUX

FAAC BENELUX NV/SA
Brugge, Belgium
tel. +32 50 320202
www.faacbenelux.com

FAAC TUBULAR MOTORS
Schaapweg 30
NL-6063 BA Vlodrop, Netherlands
tel. +31 475 406014
faactm.info@faacgroup.com
www.faacbenelux.com

AUSTRALIA

FAAC AUSTRALIA PTY LTD
Homebush – Sydney, Australia
tel. +61 2 87565644
www.faac.com.au

INDIA

FAAC INDIA PVT. LTD
Noida – Delhi, India
tel. +91 120 3934100/4199
www.faacindia.com

SWITZERLAND

FAAC AG
Altdorf, Switzerland
tel. +41 41 8713440
www.faac.ch

CHINA

FAAC SHANGHAI
Shanghai, China
tel. +86 21 68182970
www.faacgroup.cn

NORDIC REGIONS

FAAC NORDIC AB
Perstorp, Sweden
tel. +46 435 779500
www.faac.se

POLAND

FAAC POLSKA SP.ZO.O
Warszawa, Poland
tel. +48 22 8141422
www.faac.pl

UNITED KINGDOM

FAAC UK LTD.
Basingstoke - Hampshire, UK
tel. +44 1256 318100
www.faac.co.uk

SPAIN

F.A.A.C. SA
San Sebastián de los Reyes.
Madrid, Spain
tel. +34 91 6613112
www.faac.es

RUSSIA

Faac RUSSIA
Moscow, Russia
www.faac.ru

FRANCE

FAAC FRANCE
Saint Priest - Lyon, France
tel. +33 4 72218700
www.faac.fr

U.S.A.

FAAC INTERNATIONAL INC
Jacksonville, FL - U.S.A.
tel. +1 904 4488952
www.faacusa.com

MIDDLE EAST

FAAC MIDDLE EAST BRANCH
Dubai Airport Free Zone - Dubai, UAE
tel. +971 42146733
www.faac.ae

FAAC FRANCE - AGENCE PARIS
Massy - Paris, France
tel. +33 1 69191620
www.faac.fr

FAAC INTERNATIONAL INC
Fullerton, California - U.S.A.
tel. +1 714 446 9800
www.faacusa.com

FAAC FRANCE - DEPARTEMENT VOILETS
Saint Denis de Pile - Bordeaux, France
tel. +33 5 57551890
fax +33 5 57742970
www.faac.fr

732719 - Rev. A