

INSTALLATION INSTRUCTIONS AND OWNERS MANUAL

Roller Door Operator

IMPORTANT PLEASE READ THESE INSTRUCTIONS CAREFULLY PRIOR TO COMMENCING THE INSTALLATION OF THE OPERATOR UNIT

*This Automatic Opener has been designed to provide years of trouble free use.
The opener will perform efficiently only if it is installed and operated properly.*



READ THESE IMPORTANT SAFETY RULES FIRST

Keep garage door balanced. Sticking or binding doors must be repaired. Garage doors, door springs, brackets and their hardware are under extreme tension and can cause serious personal injury. **Do not attempt adjustment.** Call for professional garage door service.



Do not wear rings, watches or loose clothing while installing or servicing a garage door operator.

Installation and wiring must be in compliance with your local building and electrical codes. Connect the power cord only to properly earthed mains.



The safety reverse system test is very important. Your garage door must reverse when obstructed on closing. Failure to properly adjust the operator may result in serious personal injury from a closing garage door. Repeat the test once a month and make any needed adjustments. (See Sensitivity adjustment).

This unit should not be installed in a damp or wet space.



Use the manual release lever to disengage the motor drive **ONLY** when the drive is switched OFF and, if possible, when the door is fully closed.

Do not use the force adjustments to compensate for a binding or sticking garage door. Excessive force will interfere with the proper operation of the Safety Reverse System or damage the garage door.

Disengage all existing garage door locks to avoid damage to garage door.

Install the lighted door Control Box (or any additional Push Buttons) in a location where the garage door is visible, but out of the reach of children. Do not allow children to operate push button(s) or remote control(s). Serious personal injury from a closing garage door may result from misuse of the operator.



CAUTION: Activate operator only when the door is in full view, free of obstructions and operator is properly adjusted. No one should enter or leave the garage while the door is in motion. Do not allow children to play near the door.

Disconnect electric power to the garage door operator before making repairs or removing covers.

IMPORTANT: Fix the caution label supplied to the rear of the garage door as a reminder of safe operating procedures.

PRE-INSTALLATION NOTES

Check that there is sufficient side clearance to fit the operator unit. It may be fitted to either the right or left hand side.

DOOR TYPE	Min. Side clearance for Operator
"A" Series (25mm deep tracks)	100mm
"AA" Series (50mm deep tracks)	125mm
All doors with Windlok Tracks Subject to Drum Position	150mm

Ensure there is a properly earthed mains supply socket adjacent to where the operator is to be fitted.

If the operator is being fitted at the same time as the new door installation, read these instructions in conjunction with the door installation instructions.

If the operator is being retro-fitted, make sure the door operates smoothly and is properly balanced.

N.B.: SPECIAL CARE SHOULD BE TAKEN IF RE-TENSIONING OF THE DOOR IS REQUIRED.

At no stage should you loosen both "U" bolts if door is under tension.

IF THERE ARE ANY PROBLEMS PLEASE CONTACT YOUR LOCAL SUPPLIER OF THIS OPERATOR

INSTALLATION INSTRUCTIONS

STEP 1

Whilst the door roll is on the floor, rotate shaft backwards and forwards by hand and then release. This action will allow the roll to centralise itself on the shaft. (New installation only).

STEP 2

Fit anti-coning collar TIGHT TO DRUM at opposite end of curtain to the motor using M8 Dome Head Screw and M8 Nyloc Nut as required. Figure 1.

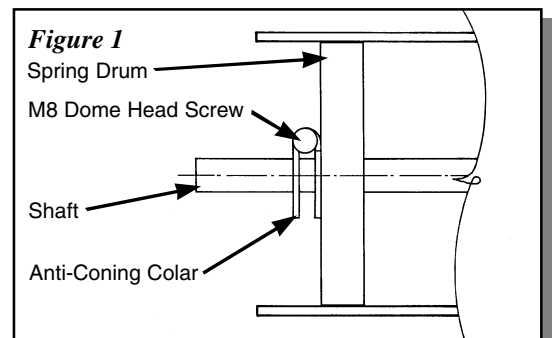

STEP 3

Slide drive unit onto shaft as shown (Figure 2) ensuring drive lugs engage fully with the narrowest spoke on drum wheel.

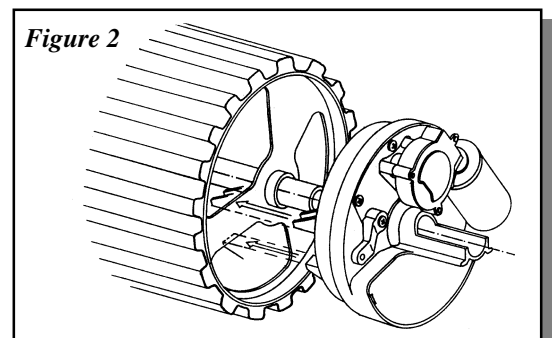

N.B.: Right-hand installation shown (inside looking out).

Lift door onto mounting brackets (ensuring curtain roll is correct way round) centralise curtain roll with opening. Refer to door installation instructions. (New installations only).

Ensure motor assembly is fully engaged with drum wheel spokes. Clamp shaft to mounting brackets using "U" Bolts supplied. (Use "U" bolt in opener pack for MOTOR end). See Figure 3.

Disengage the motor drive by pulling the manual release lever (red in colour) downwards. See Figure 3.

Tension door and complete door installation as per *Door Installation Instructions*. Ensure door is correctly balanced and is not binding or sticking within vertical tracks.

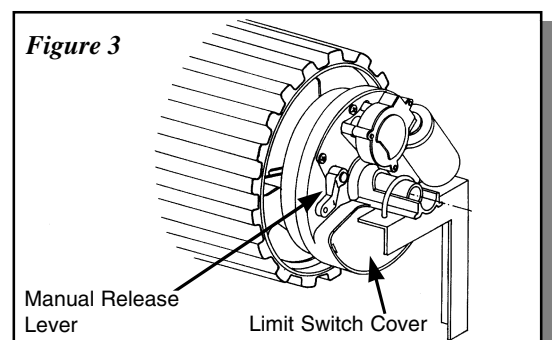

INSTALLATION INSTRUCTIONS - CONTINUED

Ensure locking bars (if fitted) are moved to the retracted (unlocked) position and keys removed from the lock.

Mount Control Unit approximately 1.6m from the floor out of the reach of children. Use No.4 x 1" self-tapping screws and rawplugs supplied. Ensure aerial is clear of all steel supports and coiled electrical leads. Fit plug from motor unit into bottom of Control Box.

Connect the control unit power cord to an adjacent socket. Ensure that the socket is properly earthed.

SETTING TOP AND BOTTOM LIMITS

N.B: Right Hand Installation only. If left hand, limit switch will be reversed.

STEP 1

Remove Limit Switch Cover Plate (See Figure 3) by carefully prising off with a small screwdriver.

STEP 2

Top limit cam "T" controls open position of door. Bottom limit cam "B" controls closed position of door.

STEP 3

Slightly loosen the three retaining screws so that the cams can be easily moved (See Figure 4).

STEP 4

Ensure that the manual release lever is still in the "disengaged" position, and manually raise the door until it is approx 100mm from the top stop position.

STEP 5

Rotate cam "T" (in the same direction that it was moving as you were manually raising the door) so that it actuates the top Limit Switch.

STEP 6

Manually lower the door until it is touching the ground.

STEP 7

Rotate cam "B" (in the same direction that it was moving as you were manually lowering the door) so that it actuates the bottom Limit Switch.

STEP 8

Tighten the three retaining screws so that the cams will not move.

STEP 9

Manually position door to halfway and re-engage the motor drive by moving the manual release lever (red in colour) to the "engage" position.

N.B: Door can now only be operated electrically, not manually. If you wish to return to manual operation, ensure power is switched *off* and move lever to "disengage" position.

STEP 10

Connect the two motor wires (Spade Connectors) (Refer Figure 5) to loose wires from the Limit Switches. Switch on power to the Control Box and operate the door from Push Button on the Control Box.

IMPORTANT: When the door is travelling in the "Up" position, hold bottom rail. The door should overload and stop. If it does not, reverse motor wires (Spade Connections).

You will need to re-adjust the Limit Cams as they will be working in a different direction.

STEP 11

Press Button on Control Box Front and check closing and stopping position.

STEP 12

If you are achieving the desired stop position, then replace the Limit Switch Cover Plate. If not, then reset the Limit Cams (Steps 2 to 9) after first turning off the mains power.

STEP 13

Once the limits have been set, fit the additional security screws (2 off self-tapping screws supplied) with the door in manual mode. With the door fully closed, mark the panel at the first point where the curtain roll touches the drum wheel, on both ends of the curtain (See Figure 6).

Raise the door slightly so that the marks can be seen and accessed from inside the garage (Figure 7).

Fit the security screws through the bottom of a corrugation and into the plastic flange of the drum wheel, on both ends of the curtain. Tighten securely.

WARNING! - Do not run door on power through its full travel until the limits are correctly set.

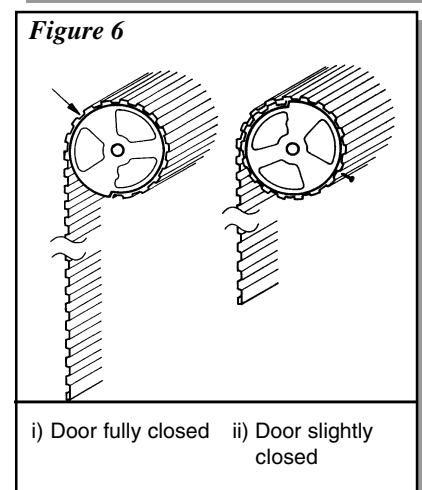
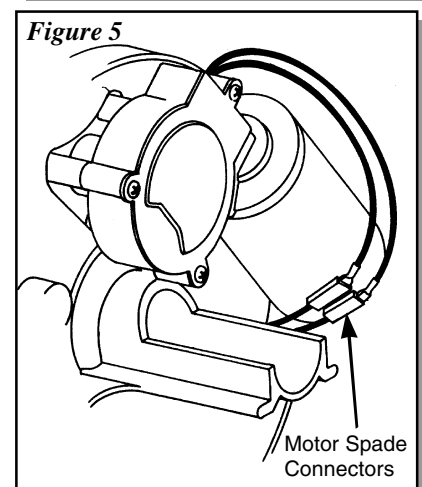
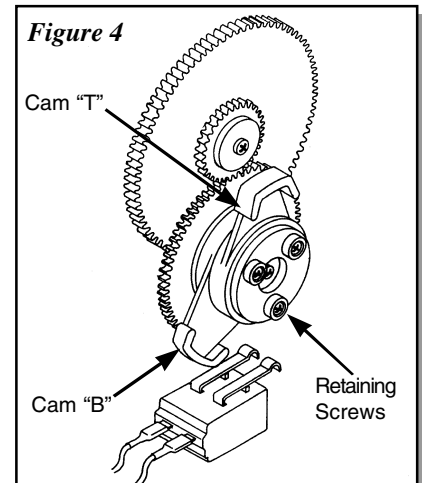

Some of these have an old big black box for a case and the light at the bottom. The Force setting is a little screw pot you can see through the housing with out opening it (Small hole in housing on left side) Turn it to the left to increase the force it seems

SENSITIVITY ADJUSTMENT

Remove cover on front of control box (Insert a screwdriver into slot at bottom of cover and bend gently downwards.)

Disengage door by moving the "Manual Release Lever". Manually extend the door to the halfway position and re-engage door.

Press the large "aqua" coloured button on the front of the control box and hold the bottom rail of the door to prevent it from travelling up. The door should *overload* and stop. If the door starts to travel downwards, swap over the "Motor Spade Connectors" and readjust "Limit Cams".

Press the small black button and then press the large "aqua" button on the front of the control box. The door should now go through four cycles (up and down) and the light will come on for the "overload alert" indication that the sensitivity adjustment is complete.

Replace front cover.

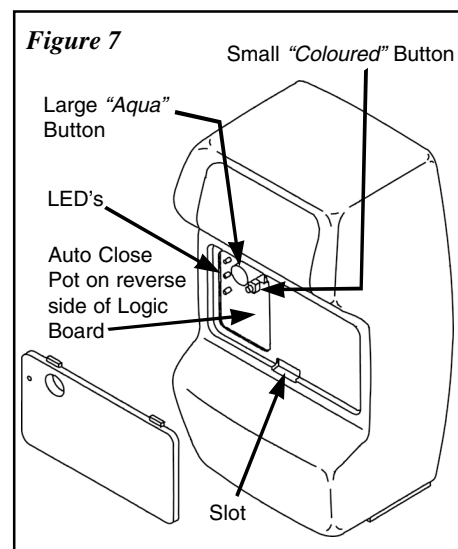

AUTO CLOSE OPTION

* **Note: Mandatory Photo Eye Protection must be used for this option.**

Contact your local supplier.

PROGRAMMING HANDSETS TO NEW CONTROL BOX

1) With the power turned onto the unit press and release the small button (learning button) and the yellow LED will come on indicating that you unit is ready to accept a code.

2) Press the handset button once. If the code is accepted the green LED will blink twice.

* **For multiple handsets code them in at this stage**

If the red light blinks twice then you have just deleted that remote from the motor as the the next section

3) Press and release the small button (learning button) and the yellow LED will go off.

You must push the yellow Learn button again to put the motor back into normal mode to test the remote or it does nothing

DELETING HANDSETS TO NEW CONTROL BOX

To delete all codes

- » Turn power off
- » Press and hold down the small button (Learning Button) while you turn the power on the 3 LED's will flash twice indicating that all codes have been deleted.

To delete individual codes (you must have the handset that you wish to delete)

- » With the power turned onto the unit press and release the small button (learning button) and the yellow LED will come on indicating that you unit is in learn mode.
- » Press the handset button twice. If the code is deleted the red LED will blink twice.
- » Press and release the small button (learning button) and the yellow LED will go off.

SERVICE INDICATOR

After 4000 operations of the door, the "courtesy light" will flash 3 times and stay on for 3 minutes as a service indicator. Please contact your local service agent.

FAULT FINDING

DOOR WILL NOT OPERATE FROM

A) Control Box

- » Check power is on to Control Unit (Red L.E.D. illuminated).
- » IF NOT, check mains plug and fuse.
- » Plug fully engaged on top of Control Box.
- » Motor wiring connections properly engaged.
- » Manual release lever in “engaged” position.
- » Limit Switch cams correctly set. i.e. upper Limit Switch for fully open position, lower Limit Switch for fully closed position.
- » Move door manually to half-closed position and try again.
- » Try operation with Hand Transmitter.

B) On Hand Transmitter

- » Check door operates correctly using the Push Button on Power Head to prove system is okay.
- » Try recoding Transmitter.
- » Check battery in Transmitter is correctly fitted. L.E.D. should illuminate.
- » Try new battery.
- » Move aerial manually and try in different orientations, keeping it away from steel structures and electrical cables.

DOOR OPERATES BUT FAILS TO FULLY OPEN OR REVERSES BEFORE CLOSING

- » Check manual operation for correct balance, not binding. Adjust if necessary.
- » Spray silicone lubricant into tracks. Do not grease.
- » Check/adjust safety sensitivity setting.
- » Check Limits.

BANGS HARD ON TRACK STOPS WHEN FULLY OPEN

- » Check top Limit Switch setting.
- » Adjust if necessary.

BANGS HARD ON GROUND AND REVERSES WHEN FULLY SHUT

- » Check bottom Limit Switch setting.
- » Adjust if necessary.

DOOR FAILS TO TRAVEL DOWN FROM OPEN POSITION - MOTOR RUNS AND ROLLER DOOR BALOONS

- » Check door curtain has smooth line of entry into tracks, as near vertical as possible.
- » Check door tension is not too great, reduce spring tension if necessary.
- » If the above does not cure the problem, then the door may require a weight bar to be fitted.

SHORT RANGE REMOTE CONTROL

- » Remote Control should give minimum of 6m range.
- » Check battery is correctly fitted in Transmitter.
- » Try new battery.
- » Move aerial and try in different orientations, keeping away from steel structures and electrical cables.

DOOR OPERATES BUT FAILS TO FULLY OPEN BUT REVERSES TO CLOSED POSITION

- » Change Motor Wire (Spade Connectors).
- » Reset Limits.
- » Re-adjust Sensitivity Adjustment.

POWER FAILURE

To disengage

- » Pull manual release lever (red handle) downwards (refer fig 3).

To engage

- » Push manual release lever up.

BOSS WARRANTY

GARAGE DOOR OPERATORS

Dated: 8 November 2002

Boss Garage Door Operators hereafter referred to as the Manufacturer hereby warrants:

1. Garage Door Operators to be free from defects in material and workmanship for a period of five (5) years for motors and one (1) year for Electronics and Mechanics from date of purchase, if installed by an authorised reseller, otherwise *if* installed by the purchaser one (1) year will apply.
2. Garage Door Operators (Commercial and Industrial Application) to be free from defects in material and workmanship for a period of three (3) months from date of purchase.
3. Where the garage door operator has been returned to the manufacturer for Warranty repairs, all costs incurred in the return will be paid for by the purchaser, if in the opinion of the manufacturer the product is faulty, all defective parts will be replaced at no charge to the purchaser.
4. Proof of purchase must be given to the manufacturer at time of Warranty claim.
5. The manufacturer reserves the right to modify any existing or future products without incurring any obligation to incorporate such modification to products already manufactured or to which this Warranty may relate.
6. Warranty only applies if this product has been installed to the Manufacturers recommendations (in the opinion of Boss Garage Door Operators).
7. This Warranty is only for goods installed in Australia.
8. This Warranty does not apply to any defect, loss or damage arising or caused directly or indirectly by or as a result of:
 - (i) Any defect (including defects in component parts or accessories) arising from or attributable to the failure to carry out normal preventive maintenance or adjustment itself.
 - (ii) To any additional damage or deterioration arising from or attributable to the operation of the Operator after it is known to be defective.
9. Exclusions to Warranty Period:
 - (i) Repair or Warranty Work - three (3) months warranty
10. Not included in Warranty:
 - (i) Batteries.
 - (ii) Fuses.
 - (iii) Globes.
 - (iv) Sensitivity adjustment.
 - (v) Hand Transmitters and receiver range.
11. Note: All Warranties will be void subject to:
 - (i) Water damage and condensation.
 - (ii) Power supply black out or surge.
 - (iii) Act of God.
 - (iv) Modification or adjustment by unauthorised persons.
 - (v) Any interference from radio (including citizen band radios or and other electronic device.)
 - (vi) Preventative maintenance as per garage door manufacturers recommendation and regular servicing not undertaken.
 - (vii) Account not paid in full by the purchaser.
12. Subject only to the provisions of the Trade Practices Act and any legislation of the State or Territory wherein the doors of the Manufacturer shall have been sold or installed (which may confer certain rights on consumers of goods and those rights by such legislation may be rendered incapable of exclusion) this Warranty supersedes and excludes all representations, warranties and conditions whether expressed or implied by law and the Manufacturer shall have no liability or otherwise than herein provided for any loss and damage (including consequential loss and damage, loss of use or profits) by reasons of delay, defective or faulty materials or workmanship, negligence or any act, matter or thing done permitted or omitted to be done by the Manufacturer.

WARRANTY

THIS WARRANTY FORM SHOULD BE COMPLETED AT TIME OF INSTALLATION.

This Warranty Form should be retained by the purchaser at all times and produced with the purchase docket by the Purchaser as proof of the purchase date.

PURCHASER'S NAME: _____

PURCHASER'S ADDRESS: _____

PURCHASED FROM: _____

INSTALLED BY: _____

INSTALLER'S ADDRESS: _____

INSTALLER'S SIGNATURE: _____

DRIVE UNIT SERIAL NO.: _____

Boss Garage Door Operators
27 Clinker Street, Darra, Qld 4076
Ph: (07) 3376 4988 Fax: (07) 3376 7071