

Control-A-Door[®] Power Drive & Roll-A-Pro[®]

Rolling Door Opener

Instruction Manual

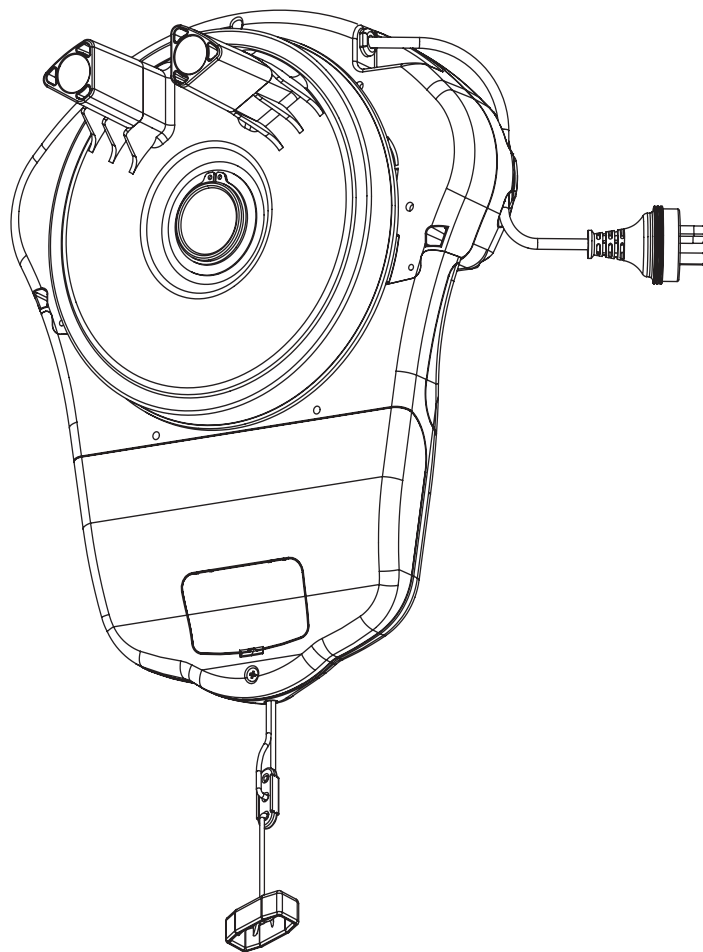

Featuring



Technology

1. Installation Safety Warnings!

This automatic garage door opener is designed and tested to offer safe service provided it is installed and operated in strict accordance with the following safety warnings. Failure to comply with the following instructions may result in death, serious personal injury or property damage.



WARNING!

- The door may operate unexpectedly, therefore do not allow anything to stay in the path of the door.
- When operating the manual release while the door is open, the door may fall rapidly due to weak or broken springs, or due to being improperly balanced.
- The drive must not be used with a door incorporating a wicket door, unless the drive cannot be operated with the wicket door open.
- The drive is intended to be installed at least 2.5m above the floor.
- Do not disengage the opener to manual operation with children/persons or any objects including motor vehicles within the doorway.
- If the door is closing and is unable to re-open when obstructed, discontinue use. Do not use a door with faulty obstruction sensing
- When using auto close mode, a Photo Electric beam must be fitted correctly and tested for operation at regular intervals. Extreme caution is recommended when using auto close mode. All safety rules must be followed.



ELECTROCUTION!

- Place opener in protected area so that it does not get wet.
- Do not spray with water .
- Disconnect the power cord from mains power before making any repairs or removing covers. Only experienced service personnel should remove covers from the opener.
- If the power supply cord is damaged, it must be replaced by an Automatic Technology service agent or suitably qualified person.
- Connect the opener to a properly earthed general purpose 240V mains power outlet installed by a qualified electrical contractor.



CAUTION:

Emergency Access

- If garage has no pedestrian entrance door, an emergency access device should be installed. This accessory allows manual operation of the garage door from outside in case of power failure.

Muscular strain

- Practice correct lifting techniques (carton weighs approx 9kgs)
- Practice correct lifting techniques when required to lift the door as per installation instructions.

Fall from ladder

- Ensure ladder is the correct type for job.
- Ensure ladder is on flat firm ground that will take the weight without the legs sinking.
- Ensure user has 3 points of contact while on ladder.

Crush injury from unsecured door

- Place a 2 metre exclusion zone around area under the door while it is unsecured.
- Do not move under a door while it is on the door support (or ladder)
- Follow the installation instructions

Garage Door

- Fit door support (or ladder) snugly under door before removing bracket.
- Ensure door support (or ladder) is on flat ground
- Examine the door installation, in particular, springs and mountings for signs of wear, damage and imbalance.
- The garage door must be well balanced. Sticking or binding doors must be repaired by a qualified garage door installer prior to installation of the opener.
- Remove or disengage all garage door locks and mechanisms prior to installation of the opener.

Entanglement

- Never plug in and operate opener prior to installation.
- Keep hands and loose clothing clear of door and guides at all times.

Entrapment under operating door

- DO NOT operate the opener unless the garage door is in full view and free from objects such as cars and children/people. Make sure that the door has finished moving before entering or leaving the garage
- In order for the opener to sense an object obstructing the door way, some force must be exerted on the object. As a result the object, door and/or person may suffer minor damage or injury.
- Ensure the garage door is in good working order by undertaking regular servicing.
- Install the optional wall transmitter in a location where the garage door is visible, but out of the reach of children at a height of at least 1.5m.
- Photo Electric beams must be installed if the closing force at the bottom edge of the door exceeds 400N (40kg)

2. Kit Contents

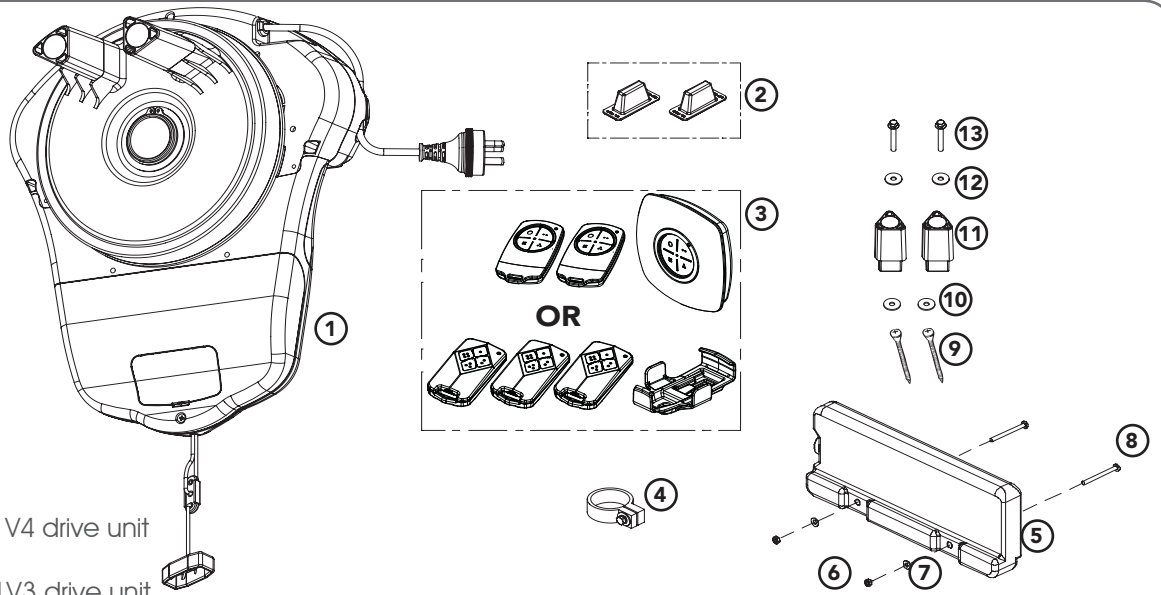

- 1. Power Drive 1 x RDO-1V4 drive unit
OR
Roll-A-Pro™ 1 x RDO-1V3 drive unit
- 2. 2 x Locking Bar Covers
- 3. Power Drive 2 x TB-6 Transmitters
1 x Wall Mount Transmitter
OR
Roll-A-Pro™ 3 x TB-5 Transmitters
1 x Wall / Visor Clip
- 4. 1 x Collar Kit
- 5. 1 x Weight Bar

Fastner Bag

- 6. 2 x Nilock Nut
- 7. 2 x 2 x 3/16 x 1/2 flat washers
- 8. 2 x Pan Head Screw M4 x 50
- 9. 2 x Self Tapping Screw M10 x 32
- 10. 2 x Washer 6.4 x 20.6 x 1.2 GAL

Accessory Pack

- 11. 2 x Extension Fork
- 12. 2 x Flat Washer 107D 6.4 x 20.5 x 1.6
- 13. 2 x Hex Serration Head Screw M6 x 45

3. Tools Required

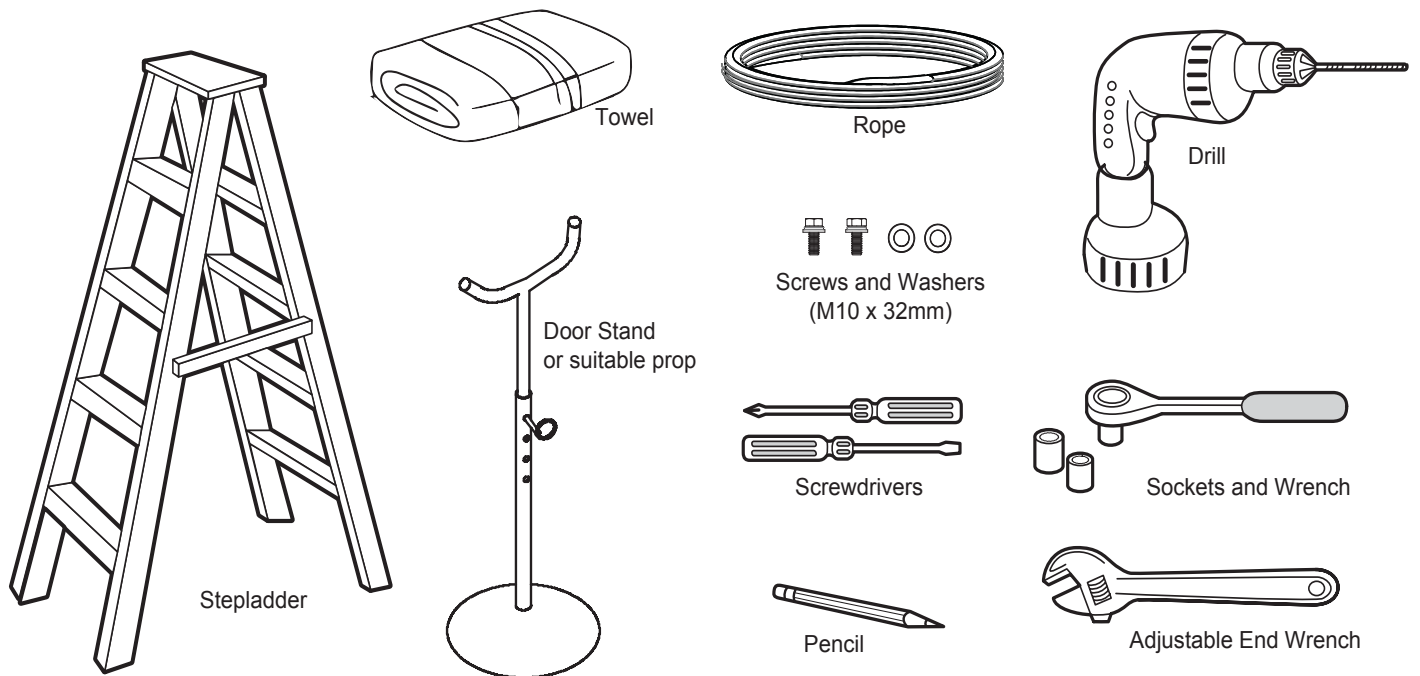

4. Setup Requirements

The Opener:

- MUST BE installed in a dry position, protected from weather. (Moisture or corrosion not covered by Warranty)
- Is factory set for RIGHT HAND SIDE installation (from inside garage), but capable of LEFT HAND SIDE installation.
- REQUIRES properly earthed 3 pin single phase power within an arms length of door and at a suitable height
- Requires a MINIMUM SIDEROOM of 41mm from the edge of the door to the inside of the door bracket and 85mm to the wall.
- CAN NOT be installed on a Door Axle Diameter that exceeds 35mm.

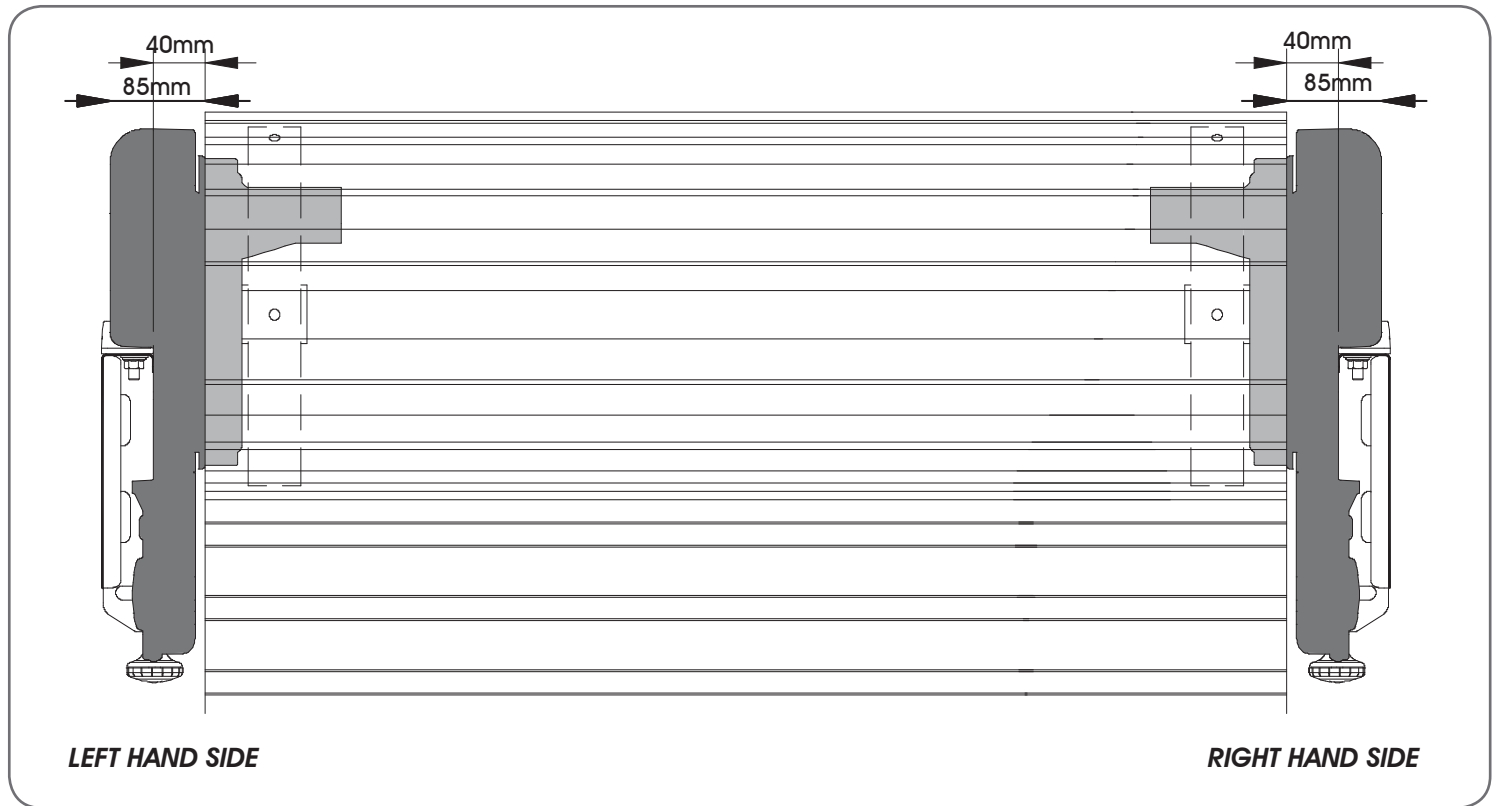

WARNING! A portable power generator is not recommended due to spikes, surges and fluctuations in the supply.

Unsuitable Door Types

The drive must not be used with a door incorporating a wicket door, unless the drive cannot be operated with the wicket door open. The fitting of an opener to doors with removable mullions is not recommended.

Sideroom

The minimum sideroom required from the edge of the door curtain is 41mm to the inside of the door bracket, and 85mm to the wall. If a Battery Backup is to be fitted, at least 135mm to the bracket is required.

Therefore the recommended sideroom from the edge of the door curtain is 95mm to the inside of the door bracket, and 135mm to the wall as per diagram.

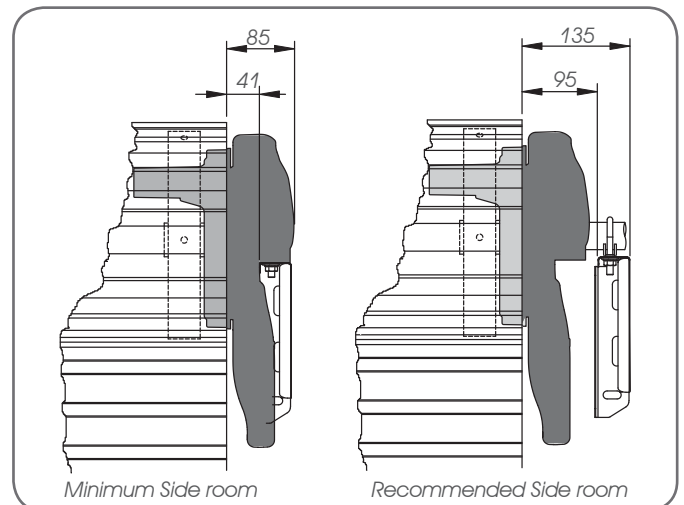

5. Door Preparation

Prepare the Door:

- Clean the guides if there is any oil or wax present using a suitable white spirit. The only lubricant suitable for use on door guides is silicon spray. DO NOT use WD-40, RP-7, petroleum grease, or similar.
- Remove the locking bars or disable the lock.
- Install the locking bar covers (2) if there are locking bar holes in the guides. This ensures fingers cannot be placed in the holes while the door operates.
- Affix the supplied warning labels where they are clearly visible on the inside of the door.
- Install the collar kit (4) to the OPPOSITE end to where the opener is being installed.
- Fit the collar kit hard up against the drum.

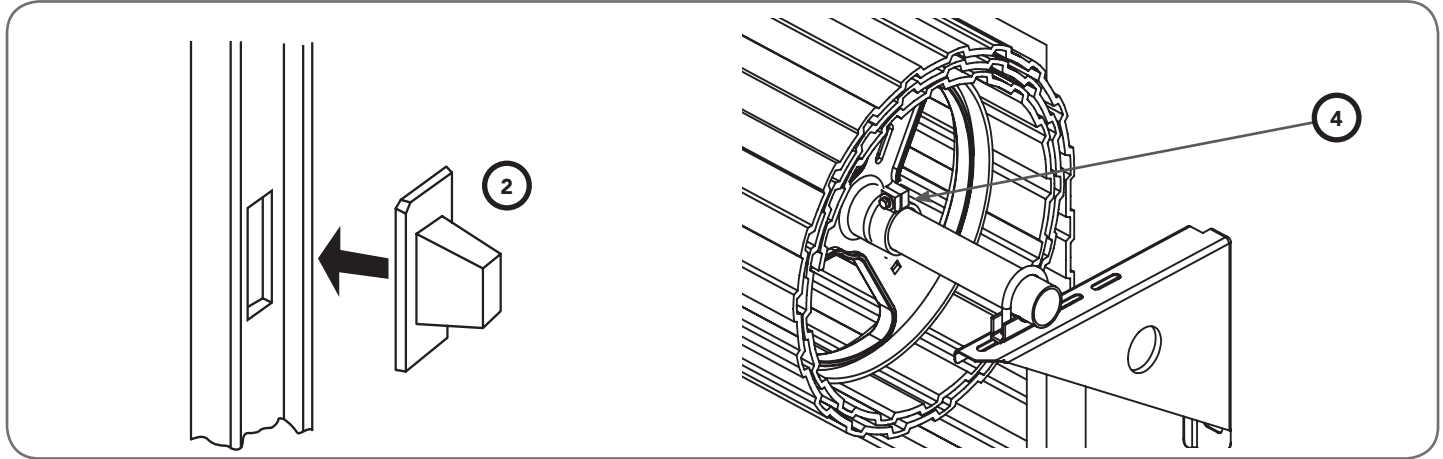

6. Fit the Weight Bar

If the door has a handle a weight bar must be fitted to ensure the door doesn't balloon during operation:

- Remove the door handle
- Fit the weight bar (5) and refit the handle using the two (2) M4x50mm Pan Head Screw (8) and the two (2) Flat Washer (7) and the two (2) M4 Nilock Hex nut (6).

If the door does not have a handle:

- Locate the centre of the door at the bottom rail.
- Place the weight bar at this point and mark the two positions where the fasteners will go
- Drill the two 4.5mm holes in the door and fit the weight bar (5) using the two (2) M4x50mm Pan Head Screw (8) and the two (2) Flat Washer (7) and the two (2) M4 Nilock Hex nut (6).
- Check that the door is still balanced and smooth. If not, then the door may require servicing.

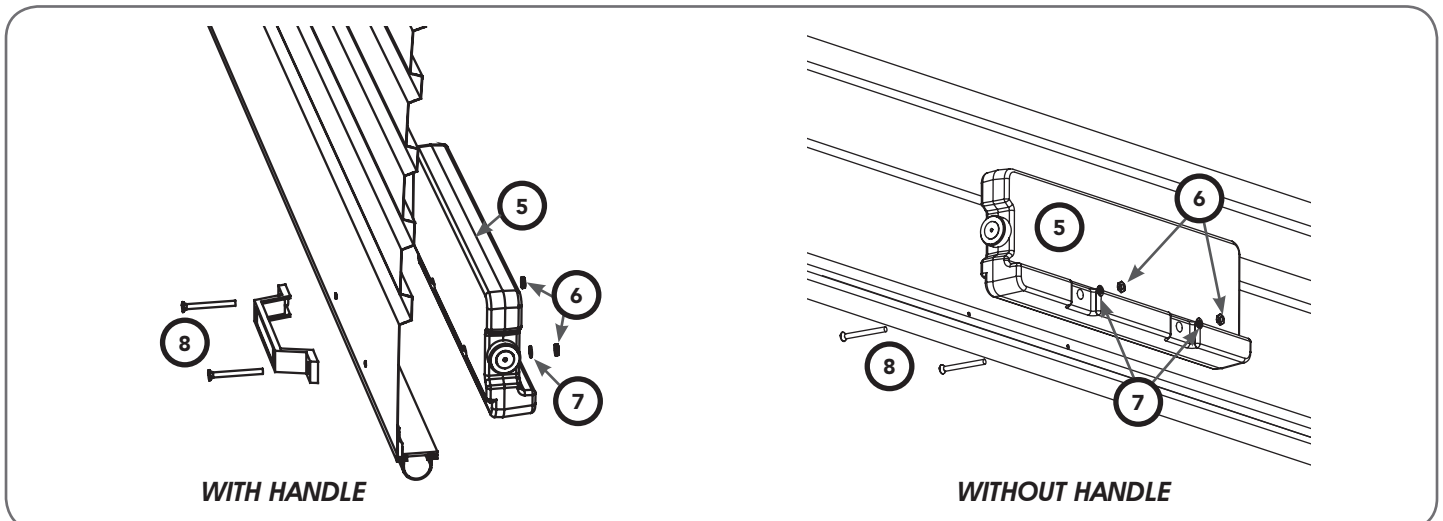

7. Pinning the Door

Pinning the Door to the drum:

Pinning the door's curtain to its drum maintains security when the opener is closed. If the curtain is not pinned the door can be partially opened manually.

- Fully close the door.
- Mark a minimum of two (2) drill holes on the drum to each end of the door.
- Drill holes using 3.2mm (1/8") drill bit.
- Fit M10 x 32mm screws and washers (not supplied) to each of the four (4) holes. This screw should be positioned as low as possible in the groove, but make sure that it does not alter the curtain's normal lead in to the guide.

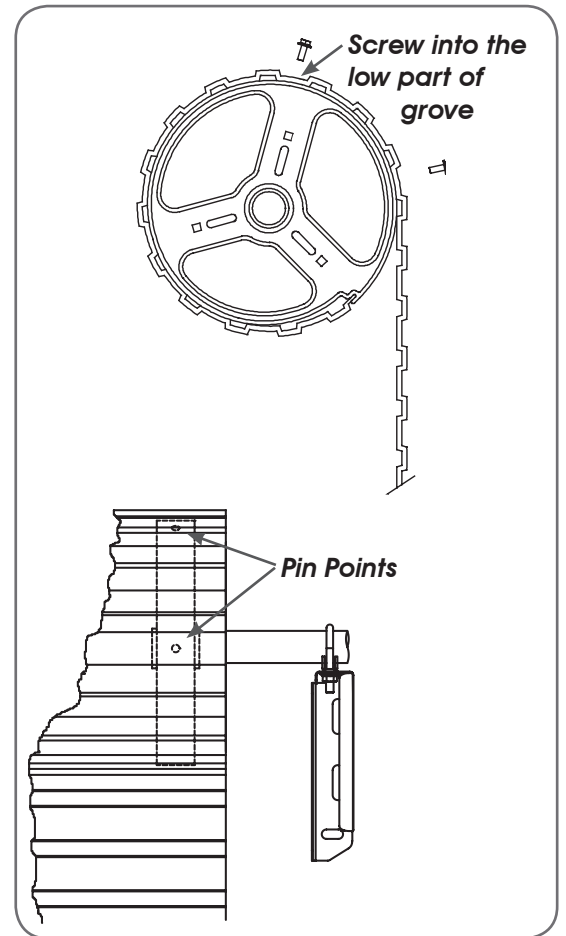
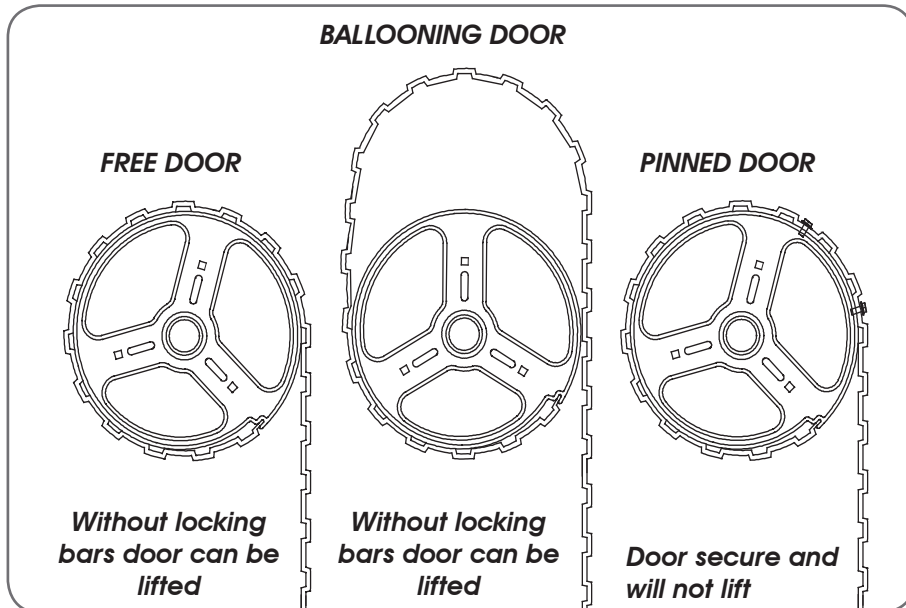

8. Propping the Door

Prepare the Door:

- At the end opposite to where the opener will be fitted, check that the U-bolt which holds the door axle to the bracket is tightened securely.



WARNING! The U-bolt must be done up tightly to ensure the stored energy in the springs cannot be unexpectedly released.

- Open the door completely and tie rope around the door roll. Do not tie the rope too tight as damage to the curtain may ensue. This will stop the door unrolling when taken off the bracket
- At the end where the opener is to be fitted, support the door with a door stand or suitable prop. Place a towel between the door and the prop to protect the door from damage.



WARNING! Make sure the prop is snug under the door and is stable.

- At the end where the opener will be fitted use a pencil to mark the position of the U-bolt in the door bracket and the position of the door bracket on the wall to assist in reassembling.

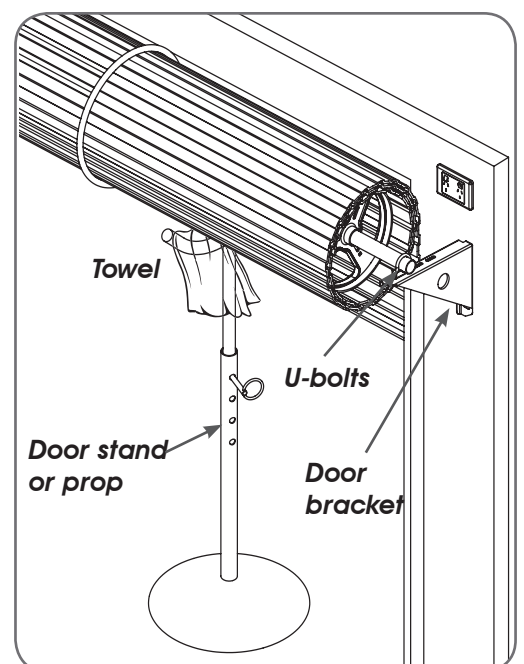

9. Mounting the Opener

Raising the Door:

- When in position, remove the U-bolt (or bolts) and saddle from the door bracket.
- Lift the door up and away from the wall until clear of the door bracket, before lowering the door to rest on the door stand or prop.

NOTE: If there is limited ceiling space to lift the door, the door bracket may have to be removed. If this is required, when refitting the door bracket, use the reference marks on the wall for correct position and ensure that it is secure to the wall and will support the door.

Mounting the Opener:

- Remove the opener from the box.
- Insert the two (2) Extension forks (11) into the ring gear.
- Secure with two (2) Flat washers (12) and two (2) Hex serration head screws (13).

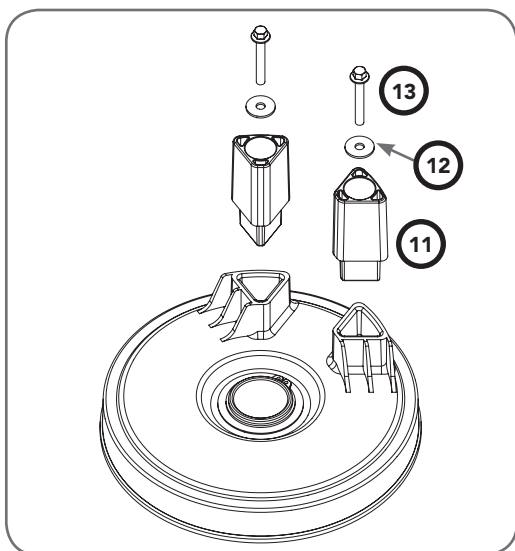

- Check the drive gear rotates freely, by pulling the string handle down (there will be a click) to disengage opener. Then move the forks from side to side by hand.
- Slide the opener over the door axle and into the drum of the door as shown.
- Push the opener in as far as possible (without interfering with the curtain) so one of the door drum's wheel spokes is between the opener's drive forks.
- Raise the door off the door stand or suitable prop.
- Lift up and over the door bracket and use your reference marks on the door bracket to position the door.
- Refit the U-bolt and nuts and tighten.
- Remove the safety rope and door stand or prop.
- Connect the power cord to a suitable powerpoint, but **DO NOT** switch on.
- Secure the power cord away from any moving object (e.g the door) with the cable clip supplied.
- With the opener still disengaged, pull the door up and down to make sure it runs freely.

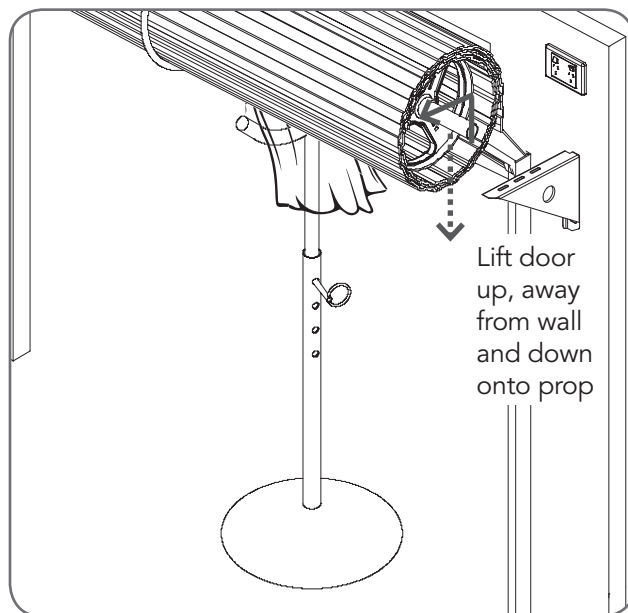

WARNING! For tight sideroom installations the door may have to be taken down.

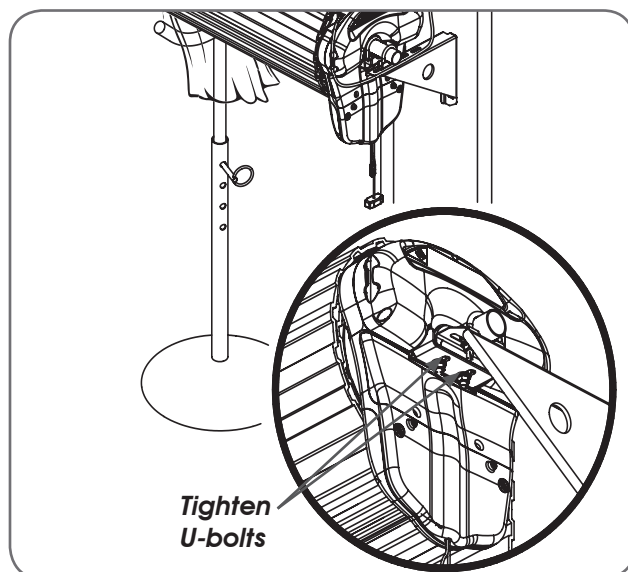
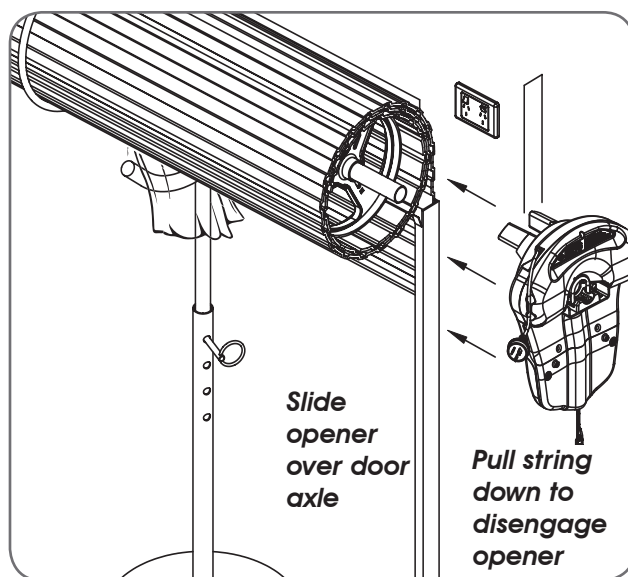

10. Setting the Travel Limits

Initial Preparation:

- Move the door to the half way position.
- Remove the clear button cover from the unit.
- Engage the opener by pulling down on the manual release string until a click sounds.
- Switch power on to the opener. The red CLOSE LIMIT LED will be flashing.
- Press and hold the MINUS (-) button - the door should start closing.

NOTE: If the door opens, release the MINUS (-) button and press the OPERATE button once to change the motor's direction.



WARNING! In setting the close limit position, do not force the door into the floor with excessive force, as this can interfere with the ease of operation of the manual release mechanism.

Set the Limit Positions:

The Limit Positions can vary due to site conditions, such as uneven ground. When setting the Close limits, ensure the position is when the door makes first contact with the ground. Alternatively for the Open limits the position should be at the height of the garage opening.

- Press and hold MINUS (-) button until the door reaches your desired close limit position. The rubber strip at the bottom of the door should form a good seal with the ground.
- Release the MINUS (-) button when the door is near the desired closed position. Single presses of the MINUS (-) button will inch the door closer to the ground.
- If the door overshoots press the PLUS (+) button to move the door in the open direction.
- When the door is at the desired close position, press the LIMIT SET button, the OPEN LIMIT LED will now flash.
- Press and hold the PLUS (+) button until the door reaches your desired open limit position. Single presses of the PLUS (+) button will inch the door open.
- If the door overshoots press the MINUS (-) button to move the door in the close direction.
- When the door is at the desired open position, press the LIMIT SET button.



WARNING! The door will automatically close, open and close again after the next step. Ensure that nothing is in the door's path.

- The door will now automatically close and open to calculate the safety obstruction settings.

Resetting the Door Limit Positions

Limit positions can be deleted by:

- Press and hold LIMIT SET button for six (6) seconds until the CLOSE LIMIT LED flashes quickly.
- Release the LIMIT SET button.

NOTE: If no action is taken within 30 seconds, the opener will return to normal operating mode and restore the original settings.

- Follow steps a - f in Set the Limits Positions to set new limit positions.

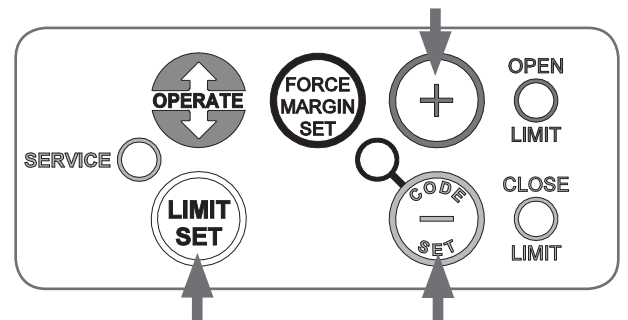
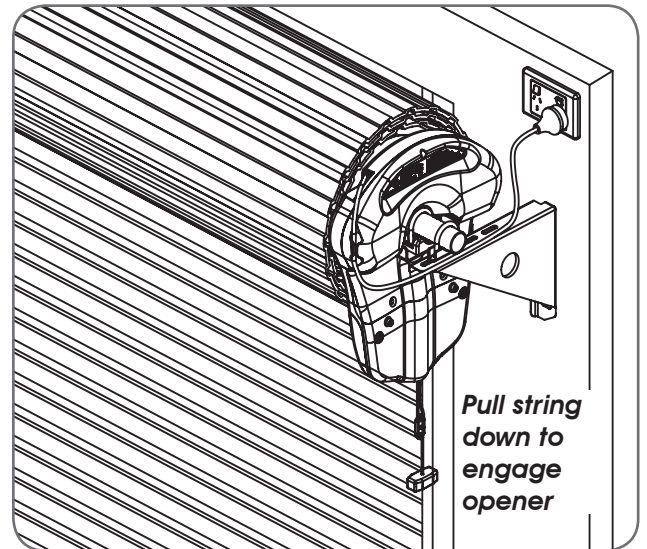

Setting the PET Mode position

When activated, PET mode drives the door to a preset position from the close position, therefore allowing a pet or parcel to go under the door.

- Drive and stop the door at the desired PET mode open position by pressing the transmitter button coded for Open/Stop/Close operation.
- Press and hold the PLUS (+) button on the opener for six (6) seconds until the OPEN and CLOSE LED's are lit to record the new PET position.
- Release the PLUS (+) button.

Reset all Factory Defaults

- Turn power to the opener off.
- Press and hold the LIMIT SET Button.
- Turn power on while holding the LIMIT SET button. Continue to hold until all LED's are off.
- This will not erase transmitter codes stored in memory.



11. Safety Testing

Test the Close Cycle

- Press the OPERATE button to open the door.
- If the door closes, press the OPERATE button to stop the door, then press OPERATE again to open.
- Place a piece of timber approximately 40mm high (or the openers cardboard box) on the floor directly under the door.
- Press the OPERATE button to close door.
- The door should strike the object and re-open.
- Remove the timber or cardboard box.

WARNING! If the door is closing and is unable to re-open when obstructed, discontinue use. Do not use a door with faulty obstruction sensing.

Testing the Open Cycle

- Press the OPERATE button to close the door.
 - Press OPERATE again to open the door.
 - When the door reaches approximately half way, firmly grab the door's bottom rail - the door should stop.
- If the door does not reverse readily when closing, or stop when opening, put the door into manual by pulling down on the manual release string to disengage the motor and contact 1300 300 625 for support.

Test the Manual Door Operation

Periodically disengage the opener and manually operate the door. The door must be smooth to operate by hand. The force required on the bottom rail should not exceed 15 kg.

Adjusting Safety Obstruction Force

The Safety Obstruction Force is calculated automatically during setup. Adjusting this is normally only necessitated by environmental conditions such as windy or dusty areas, and areas with extreme temperature changes.

To Increase Force Pressure

- Hold down the FORCE MARGIN SET button.
- While holding the FORCE MARGIN SET button, press the PLUS (+) button. Each press will increase the force margin.
- The OPEN LIMIT LED will flash each time the PLUS (+) button is pressed to indicate an increase in force.
- If the OPEN LIMIT LED flashes continuously when the PLUS (+) button is being pressed, this indicates that the maximum force setting has been reached.
- Test the force again as per Testing Close Cycle and Testing Open Cycle.

To Decrease Force Pressure

- Hold down the FORCE MARGIN SET button.
- While holding the FORCE MARGIN SET button, press the MINUS (-) button. Each press will decrease the force margin.
- The CLOSE LIMIT LED will flash each time the MINUS (-) button is pressed to indicate a decrease in force.
- If the CLOSE LIMIT LED flashes continuously when the MINUS (-) button is being pressed, this indicates that the minimum force setting has been reached.
- Test the force again as per Testing Close Cycle and Testing Open Cycle.



CAUTION: Take care when completing a safety test. Failure to follow this warning can result in serious personal injury and/or property damage.

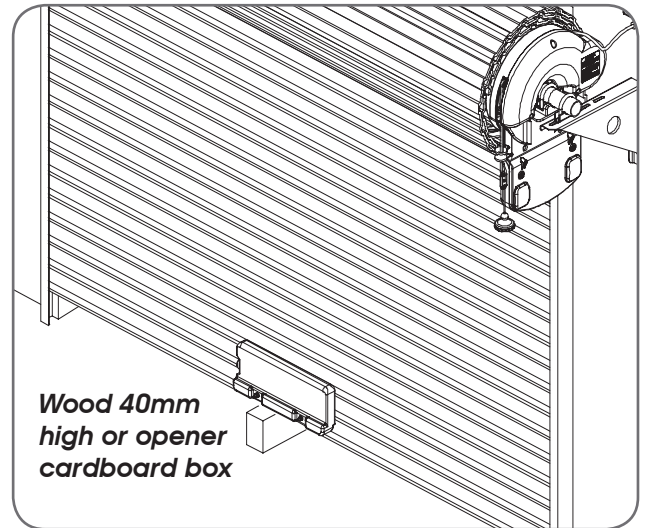

WARNING! If the door fails these tests, put the opener into manual mode, only operate the door by hand and call for service.

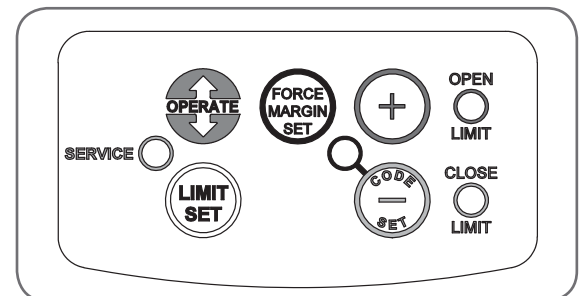

To Recall Factory Set Force

- Holding down the FORCE MARGIN SET button and the LIMIT SET button for two seconds.
- Release both buttons. The default setting should now be recalled.

To Recalculate Force Margins

- Press and hold the FORCE MARGIN SET Button for six (6) seconds, the beeper will sound once.
- The door will start to move and re-calculate force margins. The door can move between the open and close limit positions up to four (4) times (depending on the position of the door and the power up condition).
- A single beep will be heard once the process is complete.
- Test the force again as per Testing Close Cycle and Testing Open Cycle.

12. Accessories

Auxiliary Output

The auxiliary output can be used to control alarm or another garage door opener. A valid transmission from the pre-coded transmitter will cause the auxiliary output to pulse for approximately 1 (one) second. The maximum DC voltage must not exceed 35 volts DC. Maximum current must not exceed 80 ma.

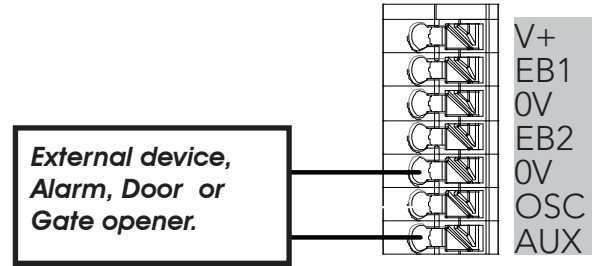

Keyswitch Connection

The RDO-1V4 has the input to connect bell switch or keyswitch to open or close the door.

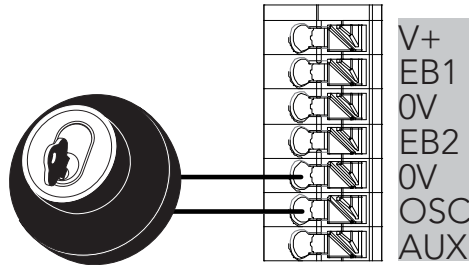

Remote Aerial

Some sites cause poor radio reception. Particularly problematic areas are those where there is a large amount of metal, like a steel garage, or an underground car park with large masses of steel reinforced concrete. These issues, and others, can create reception issues.

Poor radio reception will be noticed by a reduction in the operating range of the transmitters.

You can evaluate whether fitting an external aerial will benefit as follows;

- i. Test the maximum operating range of the transmitter with the garage door closed; then
- ii. Test the maximum operating range of the transmitter with the garage door open.

If the range improves when the door is open you can install a remote aerial kit to improve reception.

Mount the aerial to a suitable location on the outside of the garage.

Similar to a television aerial, the better the mounting position the better the reception will be. Where possible, mount the aerial as high as possible, away from masses of metal and in line of sight position, to where you normally use your transmitter.

13. Auto-Close (CAD PD Only)

Safety Beams

A Safety Beam Kit may be fitted to this opener. When this option is fitted, the operation of this device is such that if an object (i.e car, child etc) blocks the Infra-Red beam, then the garage door opener will not close the door automatically. If the Safety Beam is fitted but not operating correctly, then the door once opened automatically, will not close automatically.

Auto Close Option

Auto-Close mode is a function that automatically closes the door a preset time after the Safety Beams recognise that a vehicle has left the garage. The Auto-Close timer only starts after the Safety Beam's path is broken. If the safety beam path is not broken, the door will remain open until the path is broken. If the opener incurs a physical obstruction (i.e. not from the Safety Beams) while closing the door, it will re-open and not Auto-Close until the Safety Beam's path is broken again.

To enable the Auto-Close function remove the light diffuser from the opener and remove the AUTO-CLS (ACLS) shunt next to the programmer input and place over both ACLS inputs. When this option is selected the garage door opener will attempt to close the door automatically 30 seconds after opening. Refit the light diffuser.

WARNING! It is compulsory to have Safety Beams installed when using Auto-Close mode.

Remove shunt and place over both inputs.

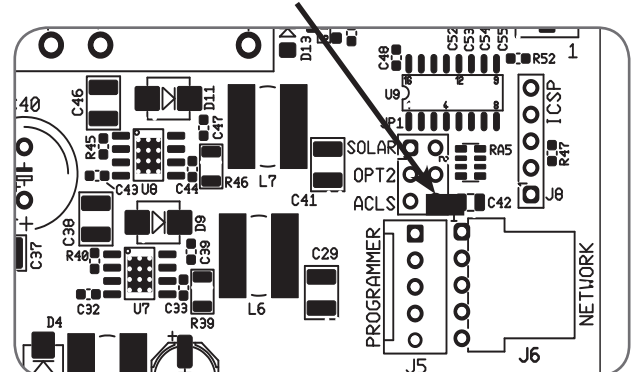

14. Coding a Transmitter

Storing the Transmitter Code

The opener can only be operated from remote control transmitters that have been programmed into its memory. Up to 64 codes can be stored in the memory.

- Press the CODE SET button and release. The CODE SET LED will illuminate to indicate the opener is in Code Learn mode. If a valid code is not stored within 15 seconds the opener will exit Code Learn.
- Press the transmitter button one (1) to control the door. The CODE SET LED will flash.
- Press the same transmitter button again. The CODE SET LED will illuminate for one second then go out.
- The transmitter button is now coded - press to test.

Coding a Transmitter to the Courtesy Light

The transmitter can be programmed to operate the courtesy light on the opener independently of the door moving.

- Press the CODE SET button twice - the CODE SET LED and courtesy light will both illuminate.
- Press one of the four buttons on the transmitter for two (2) seconds, pause for two (2) seconds, then press the same button again for two (2) seconds. The CODE SET LED will illuminate for one second then go out.
- Press the transmitter button to test.

Coding a Transmitter Button to Enable Vacation Mode

The opener can be programmed into a "Vacation Mode" where the opener will not respond to any transmitter except the button of the transmitter that was programmed for vacation mode.

- Press the CODE SET button three (3) times - the CODE SET LED will illuminate and the courtesy light will flash slowly.
- Press one of the four buttons on the transmitter for two (2) seconds, the CODE SET LED will begin to flash, pause for two (2) seconds, then press the same button again for two (2) seconds.
- The CODE SET LED will illuminate for one second and then go out, and the courtesy light will also switch off. This indicates the code has been stored.
- Press and hold the transmitter button for five (5) seconds to set Vacation Mode. The CODE SET LED will stay lit while Vacation Mode is active.
- To reset Vacation Mode, press the same button for two seconds, until the CODE SET LED turns off.

Coding a Transmitter to enable AUX Output

- Press the CODE SET button four (4) times - the CODE SET LED will illuminate and the courtesy light will flash quickly.
- Press one of the four buttons on the transmitter for two (2) seconds, the CODE SET LED will begin to flash, pause for two (2) seconds, then press the same button again for two (2) seconds. The CODE SET LED will illuminate for one second then go out.
- Press the transmitter button to test.

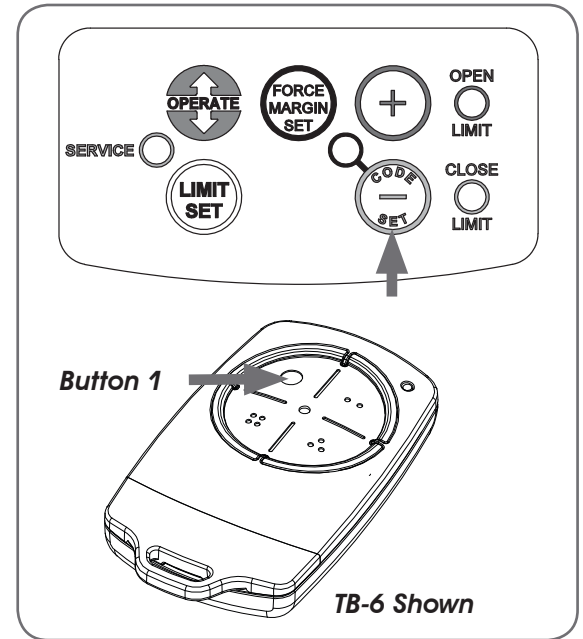

IMPORTANT NOTE: Only Tri-Tran+™ Technology Transmitters are compatible with these RDO-1 products.

14. Coding a Transmitter

Setting the Transmitter to Operate PET (Pedestrian) Mode

The PET mode position (see Programming the Opener) must be set prior to coding a transmitter.

- Press the CODE SET button five (5) times - the CODE SET LED will illuminate and the courtesy light will flash quickly (twice per second).
- Press one of the four (4) buttons on the transmitter for two (2) seconds, the CODE SET LED will begin to flash, pause for two (2) seconds, then press the same button again for two (2) seconds.
- The CODE SET LED will illuminate for one second and then go out, and the courtesy light will also switch off. This indicates the code has been stored.
- Press the transmitter button to test.

Installation of the Wall Mounted Transmitter (RDO-1V4 Only)

- Mount the transmitter in a convenient location, yet out of reach of children and at least 1.5m off the ground.
- Make sure the door is visible from this location.
- To set the transmitter press the CODE SET button and release. The CODE SET LED will illuminate to indicate the opener is in Code Learn mode. If a valid code is not stored within 15 seconds the opener will exit Code Learn.
- Press the transmitter button (one of four) that you want to control the door. The CODE SET LED will flash.
- Press the same transmitter button again. The CODE SET LED will illuminate for one second then go out.
- The transmitter button is now coded - press to test

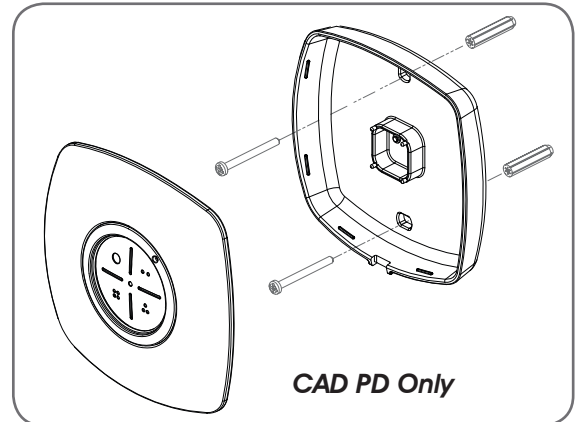

Remotely Coding Transmitters

Using this method transmitters can be coded without access to the opener's control panel as long as a pre-coded transmitter is available.

- Take any pre-coded transmitter. Press the button for the function to be duplicated and release.
- Using a small needle / pen, press and hold firmly for two seconds the middle button, through the Coding Hole.
- Within ten (10) seconds take the additional transmitter you wish to code. Hold the new transmitter's button for two seconds, pause for two seconds, hold again for two seconds and then release.
- Wait for ten (10) seconds and then press the new transmitter's button to test.

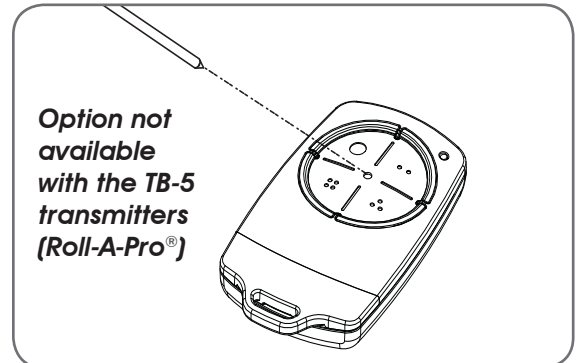

Erasing Programmed Codes

If the CODE SET button is pressed and held for six (6) seconds the CODE SET LED will blink rapidly for one second to indicate that all programmed codes have been erased.

15. Home Owner Safety Warnings!

This automatic garage door opener is designed and tested to offer safe service provided it is installed and operated in strict accordance with the following safety warnings. Failure to comply with the following instructions may result in death, serious personal injury or property damage.

Please read these important safety warnings!



WARNING!

- When operating the manual release while the door is open, the door may fall rapidly due to weak or broken springs, or due to being improperly balanced.
- **DO NOT** disengage the opener to manual operation with children/persons or any objects including motor vehicles within the doorway.
- If the door is closing and does not re-open when obstructed, discontinue use. **DO NOT** use a door with faulty obstruction sensing.



ELECTROCUTION!

- Place opener in protected area so that it does not get wet.
- **DO NOT** spray with water .
- **DO NOT** open the protective covers.
- **DO NOT** operate opener if cable is damaged.



DO NOT DO IT YOURSELF

- Keep the garage door balanced. Sticking or binding doors must be repaired. Garage doors, door springs, brackets and their hardware are under extreme tension and can cause serious personal injury. **DO NOT** attempt any garage door adjustment. **DO NOT** use if repair or adjustment is needed. Call for a professional garage door service.



CAUTION:

Emergency access

Entrapment under operating door

Fall from Ladder

Entanglement in or laceration from moving door

- If your garage has no pedestrian entrance door, an emergency access device should be installed. This accessory allows manual operation of the garage door from outside in case of power failure.
- Watch the moving door and keep people away until the door is completely opened or closed. **DO NOT** operate door when persons are near the door.
- **DO NOT** allow children to play with door controls or transmitters.
- Regularly conduct Open and Close cycle testing.
- Ensure the garage door is in good working order by undertaking regular servicing.
- Wall transmitters should be installed in a location where the garage door is visible, but out of the reach of children at a height of at least 1.5m.
- Install Safety Beams (recommended).
- Ensure ladder is the correct type for the job.
- Ensure ladder is on flat ground.
- Ensure user has 3 points of contact while on ladder.
- Keep hands and loose clothing clear of door and guides at all times.
- Keep hands clear of moving door as sharp edges can cause cuts or lacerations.

B&D Doors to the extent that such may be lawfully excluded hereby expressly disclaims all conditions or warranties, statutory or otherwise which may be implied by laws as conditions or warranties of purchase of a B&D Garage Door Opener. B&D Doors hereby further expressly excludes all or any liability for any injury, damage, cost, expense or claim whatsoever suffered by any person as a result whether directly or indirectly from failure to install the B&D Garage Door Opener in accordance with the installation instructions.



16. Opener Safety & Security

Your Door CAN NOT be used by the opener when:

- a. There is a locking device installed.
- b. There is a power failure.

Your Door CAN be used when:

- a. There is an emergency, by disengaging the opener.
- b. There is a power failure, by disengaging the opener.

To Disengage the Opener:

- a. It is recommended to do so with the door in the closed position.
- b. Pull down on the manual release cord, until you hear a click.
- c. Move the door manually.

CAUTION: When the opener is manually disengaged, the door is no longer locked. To lock the door manually, re-engage the opener after the door is closed.

To Re-Engage the Opener:

- a. Check the door has not been locked by a locking device.
- b. Pull down on the manual release cord, until you hear a click.
- c. The door will now operate from the opener.

WARNING! Please test the manual release mechanism to ensure that the manual release is easy to operate. No more than 15 kg of force should be required to disengage the door using the manual release cord. If excessive force is required reset the close limit position (Section 10. Resetting Door Limits).

WARNING! When operating the manual release (while the door is open) the door may fall rapidly due to weak or broken springs, or due to being improperly balanced.
Do not disengage the opener to manual operation with children/persons or any objects including motor vehicles within the doorway.

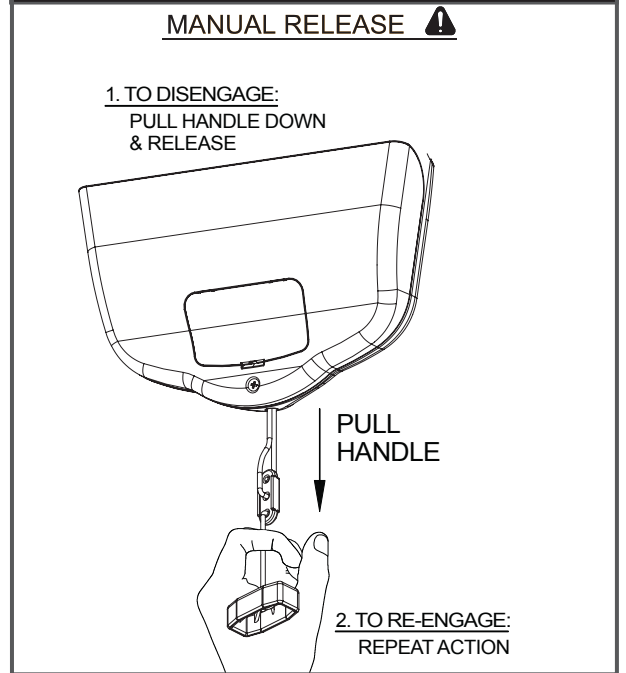

17. Operating your Opener

To Operate the opener:

- a. Press the programmed transmitter button until your door begins to move (usually 2 seconds). Make sure you can see the door when you use the transmitter.
- b. If you are in a vehicle you should aim the transmitter through your windscreen as shown.
- c. Check that the door is fully open or closed before you drive in or away.
- d. If you press the transmitter whilst the door is moving the door will stop. The next press of the transmitter will move the door in the opposite direction.

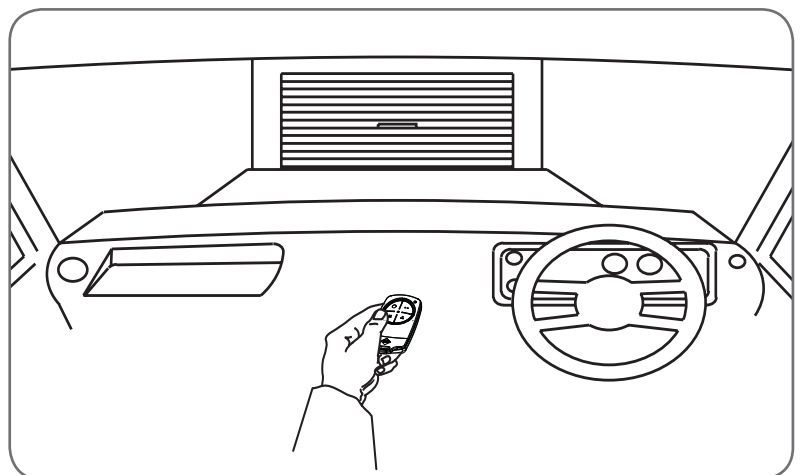

18. User Operating Controls

Button (Fig 5.1)	Function
1. OPERATE	Opens/stops/closes the door.
2. CODE SET LED (Red)	Flashes when a code is being stored or when the transmitter button is pressed
3. CLOSE LIMIT LED (Red)	Illuminates and flashes as the door closes, and remains on when the close limit position has been reached.
4. OPEN LIMIT LED (Green)	Illuminates and flashes as the door opens and remains on when the open limit position has been reached.
5. SERVICE LED (Yellow)	Indicates when the opener requires service or repairs.
6. CODE SET and MINUS (-)	Is used for storing or erasing transmitter buttons for door operation

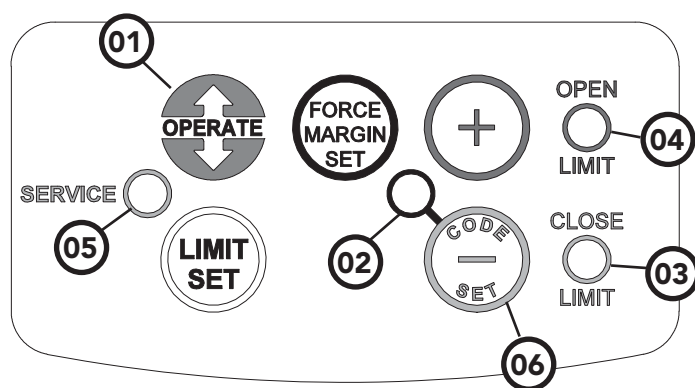

19. Door Status Indicators

Door Status Indicators	OPEN LED (green)	CLOSE LED (red)	Beeper
Open	On		
Close		On	
Opening	Flashing		
Closing		Flashing	
Door travel stopped	Flashing	Flashing	
Door obstructed when opening	Flashing		Beeps while door is moving
Door obstructed when closing		Flashing	Beeps while door is moving
Opener overloaded	Alternating flashes	Alternating flashes	
Mains power interrupted	Rapid flashes		

20. Specifications

Technical Specifications	Controll-A-Door® Power Drive	Roll-A-Pro®
Power supply	230V - 240Va.c. 50Hz	230V - 240Va.c. 50Hz
Maximum door opening Door Height:	3.25 turns of the drum wheel (approx. 3000mm)	3.25 turns of the drum wheel (approx. 3000mm)
Maximum Door Weight: Door Area:	110kg 16.5m ²	110kg 15.0m ²
Door must be well balanced and able to be operated by hand, as per warranty conditions and standard AS/NZS 4505:2012		
Minimum sideroom	41mm	41mm
Lift Force	600N (60kg)	500N (50kg)
Nominal force	150N (15kg)	150N (15kg)
Receiver type	Multi-frequency UHF FM (433.47, 433.92 & 434.37MHz)	Multi-frequency UHF FM (433.47, 433.92 & 434.37MHz)
Receiver code storage capacity	64 x Tri-Tran+ 4-button Transmitters	8 x Tri-Tran+ 4-button Transmitters
Coding System	Tri-Tran+ Technology	Tri-Tran+ Technology
Coding type	Non-linear encryption algorithm	Non-linear encryption algorithm
Number of code combinations	Over 100 billion random codes	Over 100 billion random codes
Transmitter battery	CR2032 (3 Volts)	CR2032 (3 Volts)
Courtesy light	LED (Light Emitting Diodes)	LED (Light Emitting Diodes)

Note: Intermittent operations may occur in areas which experience very strong winds. The strong wind puts extra pressure on the door and tracks which may in turn intermittently trigger the safety obstruction detection system.

21. Troubleshooting

Symptom	Possible cause	Remedy
The opener does not work from the transmitter	The opener does not have power	Plug a device of similar voltage (e.g. a hairdryer) into the power point and check that it is OK
	The battery in the transmitter is flat	Replace the battery
	Transmitter does not contain Tri-Tran+ Technology	Check that the transmitter has grey buttons and the model number on the back displays V2. Contact dealer for support if otherwise.
	The opener has been put into "Vacation Mode"	Turn off "Vacation Mode" (Section 14)
	The transmitter button is not programmed to operate the door.	Code in the transmitter
One transmitter works but the other/s do not	Door Code LED is flashing yet the opener is not working.	Ensure the correct button on the transmitter is being pressed.
	Faulty transmitter	Replace transmitter
The motor is running but the door remains stationary	Flat battery	Replace battery
	The opener is disengaged	Re-engage the opener
The transmitter range varies or is restricted	Variations are normal depending on conditions e.g. temperature or external interference	Make sure you can see the door when you use the transmitter.
	The battery life is exhausted	Check the battery status by pressing a button (flashing or no light requires battery to be changed)
	Position of the transmitter in the motor vehicle	Aim the transmitter through the windscreen.
The Courtesy light does not work	LED has failed	Change LED.
The door reverses for no apparent reason	This may occur occasionally from environmental conditions such as areas that are windy, dusty or have extreme temperature changes.	Ensure the door runs smoothly before increasing the force pressure.
	If Safety beams are installed they may be partially obstructed.	Ensure the beam path is not obstructed. Check the Alignment.
The door stops or moves very slowly.	Garage door in poor condition e.g. springs may be broken.	Check the door's operation.
	(Optional Battery Back Up Accessory) The batteries may have little OR no charge	Connect mains power and leave the batteries to charge. The batteries may take 24 to 48 hours to reach their maximum charge capacity.



21 Troubleshooting

Symptom	Possible cause	Remedy
The SERVICE LED has started to flash and is beeping numerous times	A Fault has been detected. The fault will be active each time an attempt is made to operate the door.	Record opener function (How many beeps?) then press the LIMIT SET button once to reset the opener. If the fault continues to be tripped contact 1300 300 625 for support.
The Open (Green) LED and Close (Red) LED are flashing alternatively	Opener is overloaded	Check the doors operation by disengaging the motor and ensuring the door runs smoothly. If necessary make door adjustments or discontinue use and contact 1300 300 625 for support.
The Open (Green) LED continues to flash	Door obstructed when opening	Clear away any obstructions and test door opens correctly. (If door is damaged, contact your door professional).
The Close (Red) LED continues to flash	Door obstructed when closing Limits may be cleared	Clear away any obstructions and test door closes correctly. (If door is damaged, contact your door professional). Remove all power sources (including the battery backup). Wait till all lights are out (10-15 secs), then reconnect power. If Red LED is flashing, limits are not set. Reset Limits.

Date	Time	Number of Beeps

If You Need a Service Call

If the opener needs a service please call the dealer who installed the garage door opener (their contact details are usually on a sticker on the back of your garage door). For product assistance contact 13 62 63 within Australia.

BEFORE CALLING you should have the following information to assist in providing the appropriate service:

1. Has anything happened since the opener last operated OK, e.g. a storm, a jolt to the door etc.?
2. What is the current light status on the opener?
3. Manually disengage the door (Section 16).
How easy is it to manually open and close the door?
4. What model is the opener? (Model no. information is located at the rear of the opener)
5. Who installed the opener? (Dealer details should be on a sticker on the back of your garage door)
6. When was it installed? (If known)



22. Maintenance

Door Maintenance

A poorly maintained door could cause fatal / serious injuries or damage to property.

- Frequently examine the door, particularly the cables, springs and mountings for signs of wear, damage or imbalance. **DO NOT USE** if repair or adjustment is needed since a fault in the installation or an incorrectly balanced door may cause injury.
- Fasteners: Check all screws, nuts and bolts to ensure they are secure.
- Spring Tension: It is natural for springs to lose tension. Should the door become hard to operate or completely inoperative, contact a door professional.
- Guide Tracks: Clean the internal sections of the guide tracks every 3 - 6 months with a cloth dampened with mineral turps or methylated spirits.



WARNING! Failure to maintain your garage door may void the warranty on your garage door opener.



DO NOT DO IT YOURSELF:

Door adjustments should only be carried out by experienced persons, as this function can be dangerous if not performed under strict safety procedures.



Run the Safety Testing procedures MONTHLY in Section 11 to ensure garage door is fit for use.

23. Battery Replacement

Battery Type:

3V Lithium Battery CR2032.

- To test the battery is working, press and hold a transmitter button. Check Light Status table to determine if battery needs replacing

Light Status	Battery Status
Solid	OK
Flashing	Requires replacement
No light	Requires replacement

- Use finger nails to separate the transmitter casing to expose circuit board.
- Use a non-metallic object (e.g. pen) to remove the battery.

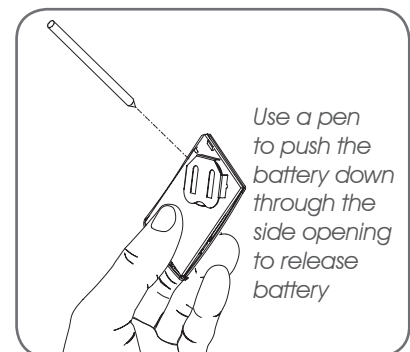

24. Battery Disposal

When batteries reach the end of their usual life in accordance with Australian Battery Recycling Initiative please follow the next simple steps for protecting the environment. Refer to the Automatic Technology website for information on where to recycle batteries in Australia.



DO NOT throw the batteries in municipal waste. This symbol of the crossed out wheeled bin indicates that the battery should not be placed in the municipal waste. Check your local regulations for appropriate disposal of the batteries.

Recycling all batteries will have other environmental and social benefits:

- Some batteries are less toxic but hazardous for other reasons. Lithium batteries can explode or catch fire in landfill, while button cells are dangerous if swallowed by children. Recycling offers a safe and environmentally responsible solution for end of life batteries.
- Battery recycling recovers non-renewable materials such as lead, cadmium, stella, zinc, manganese, cobalt, silver, plastics and rare earth elements.
- Removal of batteries and other hazardous household products from household waste facilitates the recovery of organic materials through alternative waste technologies such as composting. Batteries and heavy metals are known contaminants in compost.
- The community supports recycling because it reduces waste to landfill and achieves environmental benefits.



WARNING! Prior to disposal, recycling, or collection, all battery terminals must be securely insulated with a non conductive material to prevent any two batteries from short circuiting and generating heat during storage or transport. Battery terminals may be insulated with electrical tape; or batteries may be individually packaged in a non conductive material (e.g., plastic bag or original packaging).

25. Service Schedule

Year / Approx. Cycles	Date	Details
1 / 3,000		
2 / 6,000		
3 / 9,000		
4 / 12,000		
5 / 15,000		

B&D Doors is a division of B&D Australia Pty Ltd
Phone: 13 62 63
Website: www.bnd.com.au



26. Warranty

Product: Controll-A-Door® Power Drive and Roll-A-Pro®

Purchased from: _____ Purchaser: _____
(described as "you" below)

Address: _____ Installed by: _____

Installed on (date): _____ Invoice No: _____

1. MAKING A CLAIM -

To make a warranty claim you must:

- produce a copy of the receipt of purchase, together with this warranty certificate with the above details completed; and
- where the Product has been sold by B&D, make all warranty claims directly with B&D by sending it to B&D at the relevant address set out in paragraph 2 below; or
- where the Product has been sold by an approved distributor, make all warranty claims directly with the approved distributor. If you are unsure of the correct address of the approved distributor from which you purchased the product, you can send your claim to B&D with the rest of the above details completed, including the original invoice number, and we will forward it to the distributor.

You are responsible for the expense of making a claim under this warranty.

2. B&D OR APPROVED DISTRIBUTORS ONLY -

This warranty is in addition to any statutory, non-excludable guarantees or warranty rights under Australian or New Zealand laws (as applicable). This warranty applies only to Products sold by B&D or its approved distributor. "B&D" means in Australia - B&D Doors of 34 – 36 Marigold St, Revesby NSW 2212 and in New Zealand - B&D Doors (NZ) Limited of 30C Allens Road, East Tamaki Auckland. "Approved distributor" means an approved reseller of B&D products purchasing on open account, from B&D, for the purpose of supplying those products to end users.

3. WHAT THE WARRANTY COVERS -

B&D warrants, subject to paragraph 4, that it will, at its option, either repair or replace (in a manner B&D considers reasonable) any proven defects:

- in installation for a period of one year from the date of installation where the CAD Power Drive or Roll-A-Pro™ (Product) has been installed by B&D or its approved distributor;
- in materials, manufacture or workmanship in the Product, as follows:
 - for all components of the Product that make up the power head (including any track assembly) that is attached to a garage door and that are installed by B&D or an approved distributor, the warranty will be valid for:
 - Controll-A-Door® Power Drive - a period of seven (7) years or 20,000 cycles, which ever occurs first, provided that the Product is serviced annually by B&D or its approved distributor;
 - Roll-A-Pro® - a period of five (5) years or 10,000 cycles, which ever occurs first, provided that the Product is serviced annually by B&D or its approved distributor;
 - for all components of the Product that make up the power head (including any track assembly) that is attached to a garage door and that are not installed by B&D or an approved distributor, the warranty is valid for a period of one year, provided that all costs of disconnection, reinstallation and return freight are to be borne by you;
 - for all other components of the Product the warranty is valid for a period of one year; and

in each case the warranty applies from the later of the date of purchase, delivery or installation by B&D or an approved distributor (as applicable).

4. WHAT THE WARRANTY DOES NOT COVER -

This warranty does not cover:

- batteries or globes - B&D will not be liable for any defect or failure in them;
- adjustments - (as described in the Instruction Manual provided with the Product) which are not defects - you will need to pay for any service calls for adjustments;
- model modifications - B&D will not be required to incorporate modifications made to existing/future Product models;
- travel expenses - incurred by B&D or its approved distributor in either travelling to and from or transporting the Product to/from areas outside a capital city metropolitan area - you will need to pay for these expenses; or
- additional access expenses - incurred by B&D or an approved distributor in obtaining access where the Product is not readily accessible - you will need to pay for those additional expenses.

5. WHAT VOIDS THE WARRANTY -

Subject to paragraph 6, this warranty does not extend to, and B&D will be relieved of, all obligations, responsibilities and liabilities in the event that defects in the Product are directly or indirectly, in the opinion of B&D, due to or resulting from:

- unreasonable use - the Product not being used correctly in accordance with the Instruction Manual or other unreasonable use;
- instructions - failure to observe any instructions or directions (including "warning" notifications in the Instruction Manual), provided with the Product or given to you;

- other devices - the Product being fitted to any door or other closing device which is not of the type or condition defined in the Instruction Manual as suitable for installation of the Product;
- installation or adjustment - faulty installation or adjustment of the Product or door to which the Product is connected where such installation or adjustment is not carried out by B&D or its approved distributors;
- unauthorised acts - modifications or repairs made or attempted to be made by you or any unauthorised person;
- service - lack of proper maintenance, service or care of the door and Product;
- outside control - events or acts beyond the reasonable control of B&D;
- settings - use with doors locked or operation of the Product with excessively high opening or closing force settings
- wiring - faulty electrical wiring of structures to which the Product is affixed;
- interference - radio (including citizen band transmissions) or other electronic interference;
- water damage - including effects from rust and corrosion);
- salt - salt corrosion or damage to the surface coatings or base materials due to environmental conditions (such as proximity to the sea-front or similar corrosive conditions).
- continuous operating time - maximum continuous operating time exceeding 1 minute in 10;
- maximum operating force - the operating force exceeding 15kg* (150 Newton) when moving the door manually to the open or closed position;
- door size - the door surface area exceeding 15.0m²;
- modifications - any unauthorised modification to the Product;
- insects damage - damage caused by insects; or
- non-residential use - installation of a residential garage door opener in a commercial or industrial premises or in a dwelling other than a single-family dwelling.

6. STATUTORY GUARANTEES OR WARRANTIES -

Australia

If you are a consumer under the Australian Consumer Law, our goods come with guarantees that cannot be excluded under the Australian Consumer Law. You are entitled to a replacement or refund for a major failure and for compensation for any other reasonably foreseeable loss or damage. You are also entitled to have the goods repaired or replaced if the goods fail to be of acceptable quality and the failure does not amount to a major failure.

This warranty certificate and other statements contained in this document or other B&D documents given to you do not exclude, restrict or modify the application of all or any of the provisions of the Australian Consumer Law.

New Zealand

This warranty certificate and other statements contained in this document or other B&D documents given to you do not exclude, restrict or modify the application of the New Zealand Consumer Guarantees Act (collectively defined as the "Act"); or the exercise of rights conferred by other statutory provisions which cannot be excluded, restricted or modified, provided that to the extent that the Act or other statutory provision permits B&D to limit its liability for a breach of a statutory guarantee or warranty, B&D's liability for such breach is limited to the payment of the cost of replacing the Product or acquiring an equivalent Product or repairing the Product.

In Australia, this warranty is given by B&D Australia Pty Limited (ABN 25 010 473 971) of B&D Doors of 34 – 36 Marigold St, Revesby NSW 2212, phone 13 62 63 and email enquiries@bnd.com.au. In New Zealand, this warranty is given by BD Doors (NZ) Limited of 30C Allens Road, East Tamaki, Auckland, phone 09-273 8600 and email enquiries@bnd.co.nz

This warranty document is not intended to create a contract between B&D and the purchaser.



Note:

- * The door that the Product is used with should be balanced in such a way that the user is able to open or close the door manually using a force not greater than 150 Newton (15 kg), other than to initially cause the door to start moving, which may require force in excess of that specified in this paragraph.



27. Optional Accessories

There are a range of additional accessories for your added convenience and security. Contact your Dealer for installation of these accessory items.

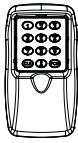
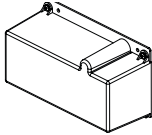
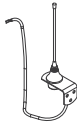
	<ul style="list-style-type: none"> • Safety Beams - Provides additional protection if the door is closing onto your property or person. Simply breaking the beam "stops" the door! 	
<p>IMPORTANT NOTE: Only Tri-Iran +™ Technology Transmitters and Keypads are compatible with these products.</p>	 <p>TB-6 Shown</p>	<ul style="list-style-type: none"> • Keyring Transmitter - Ideal for personal use when entry into the house may be via the garage. • Wall Button Transmitter - Allows you to operate the opener within 10 metres of the door. Ideal for mounting inside the house.
		<ul style="list-style-type: none"> • Wireless Keypad - The entry keypad allows entry to the garage without using a transmitter.
	<ul style="list-style-type: none"> • Battery Back-up - The opener has a provision for a Battery Back Up kit that allows continued operation of the door in the absence of mains power. (Not available with the Roll-A-Pro™) 	
	<ul style="list-style-type: none"> • External Antenna - For sites where radio range may be reduced. 	

Is your door sticking and hard to operate?

It may be time for a service
(for more details see section 22)

For a service, contact your dealer using the details below...

Dealer:

