

# DAVE

COMMERCIAL DOOR OPERATOR



DAVE's Manual



**automatic**  
TECHNOLOGY

# Contents

---

<b>1.</b>	<b>IMPORTANT SAFETY INSTRUCTIONS</b>	<b>4</b>
<b>2.</b>	<b>PRODUCT DETAILS</b>	<b>8</b>
	Technical Specifications	9
	Mounting Hardware Explained	17
<b>3.</b>	<b>CONFIGURING OPERATOR DRIVE SHAFT &amp; HANDING</b>	<b>19</b>
	Drive Shaft	20
	Manual Hauling Chain	21
<b>4.</b>	<b>INSTALLATION</b>	<b>22</b>
	Get a Load of DAVE's Flexibility!	24
	Installation Setup Options	25
	Step by Step Installation Sequence	26
	Drive Unit	30
	Wall Console	35
	Warning Placards	39
<b>5.</b>	<b>CONNECTING TO POWER</b>	<b>40</b>
	OmniVolt® Power Cartridge Details	42
	Connecting OmniVolt® Power Cartridge	43
<b>6.</b>	<b>WIRING DETAIL</b>	<b>44</b>
	Main Control Board Overview	45
	Main Control Board Terminals	46

---

<b>7. SETUP &amp; PROGRAMMING OPTIONS</b>	<b>48</b>
Pairing Wall Console	49
Wall Console Power Modes	51
Using Remote Controls (Transmitters)	52
Setting Limits	56
Operator Settings	58
Resetting to Factory Defaults	59
Programming Options Table	62

---

<b>8. SAFETY DEVICES AND OTHER CONTROL INPUTS</b>	<b>71</b>
Safety Device Setup	72
Fire System Input	77
Access Devices	79

---

<b>9. DAVE'S RELAY EXPANSION BOARD</b>	<b>82</b>
Relay Expansion Board Overview	83
Relay Board Wiring Examples	84

---

<b>10. MAINTENANCE &amp; SUPPORT</b>	<b>86</b>
Door Service Alerts	87
Maintenance Requirements	89
Troubleshooting Guide	91

# **1. IMPORTANT SAFETY INSTRUCTIONS**



## WARNING

### TO REDUCE THE RISK OF SEVERE INJURY OR DEATH:

1. **READ AND FOLLOW ALL INSTRUCTIONS.**
2. Never let children operate or play with door controls. Keep remote controls away from children.
3. Always keep the moving door in sight and away from people and objects until it is completely closed. **NO ONE SHOULD CROSS THE PATH OF THE MOVING DOOR.**
4. **NEVER GO UNDER A STOPPED, PARTIALLY OPEN DOOR.**
5. Test door operator monthly. After adjusting either the force or the limit of travel, retest the door opener. Failure to properly adjust the opener increases the risk of severe injury or death.
6. For products having an emergency release, use the emergency release only when the door is closed, if possible. Use caution when using this release with the door open. Weak or broken springs can accelerate the door downward, causing severe injury or death.
7. **KEEP OVERHEAD DOORS AND SHUTTERS PROPERLY BALANCED.** See user's manual. An improperly balanced door increases the risk of severe injury or death. A qualified service person must make repairs to cables, spring assemblies, and other hardware.
8. For operator systems equipped with an unattended or automatic closing feature, the following statement shall be posted adjacent to the wall control in accordance with UL 325:  
**"This operator has an unattended operation feature. No one should cross the path of the moving door."**
9. **SAVE THESE INSTRUCTIONS.**



## AVERTISSEMENT

### POUR RÉDUIRE LE RISQUE DE BLESSURES GRAVES, VOIRE DE MORT :

1. **LISEZ ET SUIVEZ TOUTES LES INSTRUCTIONS.**
2. Ne laissez jamais les enfants utiliser ou jouer avec les commandes de la porte. Gardez les télécommandes hors de portée des enfants.
3. Gardez toujours la porte en mouvement dans votre ligne de vision et à l'écart des personnes et des objets jusqu'à ce qu'elle soit complètement fermée. **PERSONNE NE DOIT TRAVERSER LA TRAJECTOIRE DE LA PORTE EN MOUVEMENT.**
4. **NE PAS PASSER SOUS UNE PORTE ARRÊTÉE OU PARTIELLEMENT OUVERTE.**
5. Testez l'ouvre-porte chaque mois. La porte de garage **DOIT** inverser sa course au contact d'un objet de 38 mm (1-1/2 po) ou d'une planche de 2 x 4 posée à plat sur le sol. Après avoir réglé la force ou la limite de course, refaites le test de l'ouvre-porte. Le fait de ne pas régler correctement l'ouvre-porte augmente le risque de blessures graves ou de mort.
6. Pour les produits équipés d'un déverrouillage d'urgence, utilisez ce dispositif uniquement lorsque la porte est fermée, si possible. Faites preuve de prudence lors de l'utilisation de ce dispositif lorsque la porte est ouverte. Des ressorts faibles ou cassés peuvent accélérer la descente de la porte, causant des blessures graves ou la mort.
7. **GARDEZ LES PORTES BASCULANTES ET LES VOLETS ROULANTS CORRECTEMENT ÉQUILIBRÉS.** Voir le manuel d'utilisation. Une porte mal équilibrée augmente le risque de blessures graves ou de mort. Un technicien qualifié doit effectuer les réparations des câbles, des ensembles de ressorts et des autres composants.
8. Pour les systèmes d'opérateur équipés d'une fonction de fermeture automatique ou sans surveillance, l'avertissement suivant doit être affiché à côté du bouton mural conformément à la norme UL 325 :
9. **« Cet opérateur est doté d'une fonction de fonctionnement sans surveillance. Personne ne doit traverser la trajectoire de la porte en mouvement. »**
10. **Conservez ces instructions.**

# PLEASE READ THESE IMPORTANT SAFETY RULES CAREFULLY

These safety alert symbols indicate a personal safety or property damage instruction exists.

This automatic door operator is designed and tested to offer safe service provided it is installed and operated in strict accordance with the following safety rules. Failure to comply with the installation instructions and the safety warnings may result in death, serious personal injury and/or property damage.

## **WARNING**

- The door may operate unexpectedly, therefore do not allow Anything to stay in the path of the door.
- For SAFETY protection, a Safety Beam must be fitted with logic console. Failure to comply will void the warranty and may result in serious personal injury and/or property damage .
- The drive must not be used with a door incorporating a wicket door, unless the drive cannot be operated with the wicket door open. The drive is intended to be installed at least 2.5m above the floor.
- DO NOT allow children to operate the opener. Any device that can operate the opener, make sure it is out of reach of children and that the doorway is in full view at all times. Serious personal injury and/or property damage can result from failure to follow this warning.
- When using auto close mode, a Safety (Photo Electric) Beam must be fitted correctly and tested for operation at regular intervals. Extreme caution is recommended when using auto close mode. All safety rules must be followed.

## **CAUTION:**

- If your facility has no pedestrian entrance door, an emergency access device should be installed. This accessory allows manual operation of the garage door from outside in case of power failure.
- Frequently examine the installation, in particular, springs and mountings for signs of wear, damage or imbalance. DO NOT use if repair or adjustment is needed since a fault in the installation or an incorrectly balanced door may cause injury. DO NOT attempt to repair the door yourself as hardware is under extreme tension.
- The door must be well balanced and in good working order. door springs, brackets and their hardware are under extreme tension and can cause serious personal injury. Do not attempt to adjust them. A faulty door must be repaired by an industrial service professional prior to opener installation.
- Safety beams must be installed if the closing force at the bottom edge of the door exceeds 400N (40kg)
- To avoid serious personal injury from entanglement, remove all unnecessary ropes or chains and disable any equipment such as locks which are not needed for powered operation.
- Do not wear rings, watches or loose clothing while installing or servicing a garage door operator.
- Ensure ladder is the correct type for the job and is on flat ground. We recommend the user has 3 points of contact while on ladder.
- Activate the operator only when the garage door is in full view, free of obstructions and with the operator properly adjusted.
- The operator is not intended for use by young children or infirm persons without supervision.
- Keep remote controls away from children.
- Do not allow children to play with door controls.

## **DANGER - RISK OF ELECTROCUTION:**

- Installation and wiring must be in compliance with your local building and electrical codes.
- To reduce the risk of electric shock, this equipment has a grounding type plug that has a third (grounding) pin. This plug will only fit into a grounding type outlet. If the plug does not fit into outlet, contact a qualified electrician to install the proper outlet. Do not change the plug in any way.
- If the power cord is damaged, it must be replaced by the manufacturer, its service agent or a similarly qualified person in order to avoid a hazard.
- Connect the power cord only to properly earthed mains. If an extension lead must be used, make sure it is a 3-core lead and approved to 7 amp capacity.
- This unit is not user serviceable. Unplug the power cord before removing the cover. Ensure that the power cord is attached clear of all moving parts. Ignoring these instructions can cause electric shock.
- Disconnect the power supply when cleaning or other maintenance is being carried out.

# VEUILLEZ LIRE ATTENTIVEMENT CES RÈGLES DE SÉCURITÉ IMPORTANTES

Ces symboles d'alerte de sécurité indiquent qu'il existe une consigne de sécurité pour les personnes ou les biens.

Cet ouvre-porte automatique est conçu et testé pour offrir un service sûr, à condition qu'il soit installé et utilisé en stricte conformité avec les règles de sécurité suivantes. Le non-respect des instructions d'installation et des avertissements de sécurité peut entraîner la mort, des blessures graves et/ou des dommages matériels.



## AVERTISSEMENT

- La porte peut se déplacer de façon inattendue; ne laissez rien dans la trajectoire de la porte.
- Pour la sécurité, un faisceau de sécurité doit être installé avec la console logique. Le non-respect de cette exigence annulera la garantie et peut entraîner des blessures graves ou des dommages matériels.
- Ce dispositif ne doit pas être utilisé avec une porte équipée d'un portillon, à moins qu'il ne soit impossible de faire fonctionner le dispositif lorsque le portillon est ouvert. Le dispositif doit être installé à une hauteur d'au moins 2,5 m au-dessus du sol.
- NE PERMETTEZ PAS aux enfants d'utiliser l'ouvre-porte. Tout dispositif permettant d'actionner l'ouvre-porte doit être tenu hors de portée des enfants et la porte doit toujours rester dans le champ de vision. Le non-respect de cet avertissement peut entraîner des blessures graves ou des dommages matériels.
- Lors de l'utilisation du mode de fermeture automatique, un faisceau de sécurité (photoélectrique) doit être correctement installé et testé régulièrement. Une extrême prudence est recommandée lors de l'utilisation du mode de fermeture automatique. Toutes les consignes de sécurité doivent être respectées.



## DANGER – RISQUE D'ÉLECTROCUTION:

- L'installation et le câblage doivent être conformes aux codes locaux du bâtiment et de l'électricité.
- Pour réduire le risque d'électrocution, cet appareil est équipé d'une fiche avec broche de mise à la terre. Cette fiche ne peut être branchée que dans une prise avec mise à la terre. Si la fiche n'entre pas dans la prise, faites installer une prise convenable par un électricien qualifié. Ne modifiez en aucun cas la fiche.
- Si le cordon d'alimentation est endommagé, il doit être remplacé par le fabricant, son agent de service ou une personne également qualifiée afin d'éviter tout danger.
- Branchez le cordon d'alimentation uniquement à une prise correctement mise à la terre. Si une rallonge doit être utilisée, assurez-vous qu'il s'agit d'un câble à 3 conducteurs, approuvé pour une capacité de 7 ampères.
- Cet appareil n'est pas réparable par l'utilisateur. Débranchez le cordon d'alimentation avant de retirer le couvercle. Assurez-vous que le cordon d'alimentation est dégagé de toutes les pièces mobiles. Le non-respect de ces instructions peut entraîner une électrocution.
- Débranchez l'alimentation électrique lors du nettoyage ou de toute opération de maintenance.



## ATTENTION:

- Si votre établissement ne dispose pas de porte d'entrée piétonne, un dispositif d'accès d'urgence devrait être installé. Cet accessoire permet une utilisation manuelle de la porte de garage depuis l'extérieur en cas de panne de courant.
- Examinez fréquemment l'installation, en particulier les ressorts et les fixations, afin de détecter tout signe d'usure, de dommage ou de déséquilibre. N'utilisez pas l'appareil si une réparation ou un réglage est nécessaire, car un défaut dans l'installation ou une porte mal équilibrée peut causer des blessures. N'essayez pas de réparer la porte vous-même, car les composants sont sous forte tension.
- La porte doit être bien équilibrée et en bon état de fonctionnement. Les ressorts, supports et autres composants sont sous forte tension et peuvent causer des blessures graves. N'essayez pas de les ajuster vous-même. Une porte défectueuse doit être réparée par un professionnel des portes industrielles avant l'installation de l'ouvre-porte.
- Des faisceaux de sécurité doivent être installés si la force de fermeture au bord inférieure de la porte dépasse 400 N (40 kg).
- Pour éviter de graves blessures par enchevêtrement, retirez toutes les cordes ou chaînes inutiles et désactivez tout équipement tel que les verrous qui ne sont pas nécessaires pour le fonctionnement motorisé.
- Ne portez pas de bagues, de montres ou de vêtements amples lors de l'installation ou de l'entretien d'un ouvre-porte de garage.
- Assurez-vous que l'échelle est du type approprié pour le travail et qu'elle est posée sur un sol plat. Il est recommandé de maintenir trois points de contact lors de l'utilisation de l'échelle.
- N'activez l'ouvre-porte que lorsque la porte de garage est entièrement visible, dégagée et que l'ouvre-porte est correctement réglé.
- L'ouvre-porte n'est pas destiné à être utilisé par de jeunes enfants ou des personnes infirmes sans surveillance.
- Gardez les télécommandes hors de portée des enfants.
- Ne laissez pas les enfants jouer avec les commandes de la porte.

## **2. PRODUCT DETAILS**



# Technical Specifications

## DRIVE UNIT

Motor type	PMSM
Rated Motor Power	750W (1HP)
Reducer Ratio	50 to 1
Rated Output Torque	32Nm /23.5ft.lb
Max Door Weight	Up to 1000kg / 2200lb balanced *
Max Rated Load (N)	450N
Operating Temperatures	-20°C / -4°F to +65°C /+149°F
Environment	Indoor use only
Output Shaft Diameter	25.4mm /1"
Output Shaft Length	95mm / 3.75"
Max Number of Drive Shaft Turns	58
Standard Operator Sprocket	12 teeth 10B (#50)
Optional Sprockets	10 teeth 12B (#60)
Duty Cycle	Up to 60%**
Weight of Drive Unit, Power Cartridge, Drive Shaft and Sprocket	12.75kg / 28.1lb
Remote Code Combinations	Over one trillion (AES 128 Code Encryption)
Receiver Memory capacity for Remotes	63
IP Rating	IP42 (when mounted in vertical orientation)

## WALL CONSOLE

Wireless Wall console range	
Control buttons	30m / 98.4ft
Bluetooth	15m / 49ft
Power Options	
Battery Powered	Alkaline D size 1.5V x 2 (5-year battery life***)
Power Adaptor	+5VDC/ 1A
Powered From Operator	4-core cable
Menu display LCD	4 x lines x 20 characters
LCD backlighting	Yes

**\* Note: Max door weight lifting capacity may vary based on door and operator sprocket sizes, door spring tension and selected speeds.**

**\*\* Based on a maximum 400kg balanced door weight, properly maintained and rated by the door manufacturer for 60% duty cycle operation.**

**\*\*\* Note: Battery life can be lower or higher and is dependent on the power mode selected and environmental factors**

## OmniVolt® POWER CARTRIDGE (Sold Separately)

Mains Power Supply	120-240vac 50/60Hz	230-240vac 50/60Hz
Input Power	1000W	1000W
Input Voltage Fuse	10A	10A
Max Current Consumption	10A	5A
Operating Temperatures	-20°C /-4°F to +65°C /+149°F	-20°C/-4°F to +65°C(+149°F)

**DANGER -  
RISK OF ELECTROCUTION:**

- Any permanent wiring connection must be installed by a licensed electrician in accordance with local regulations and standards

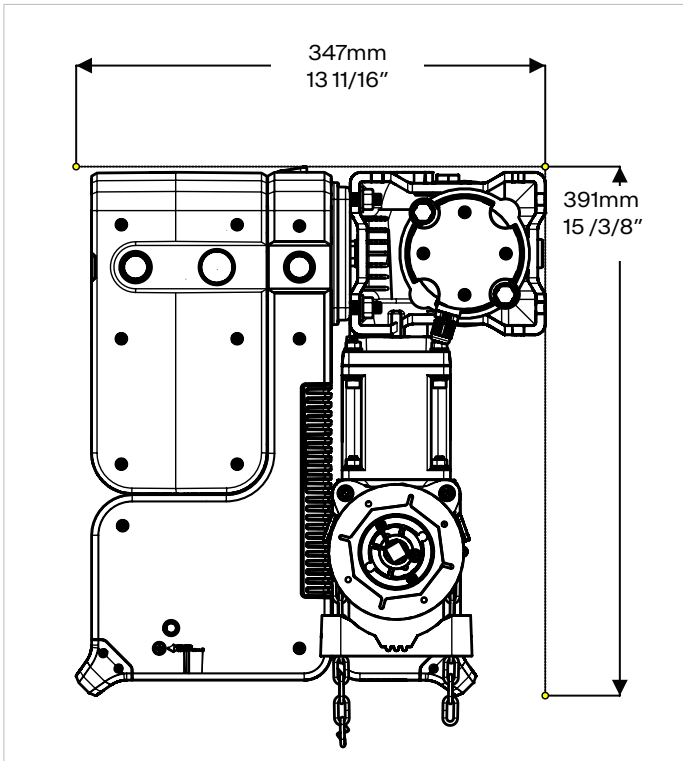

Fig:1 Side View

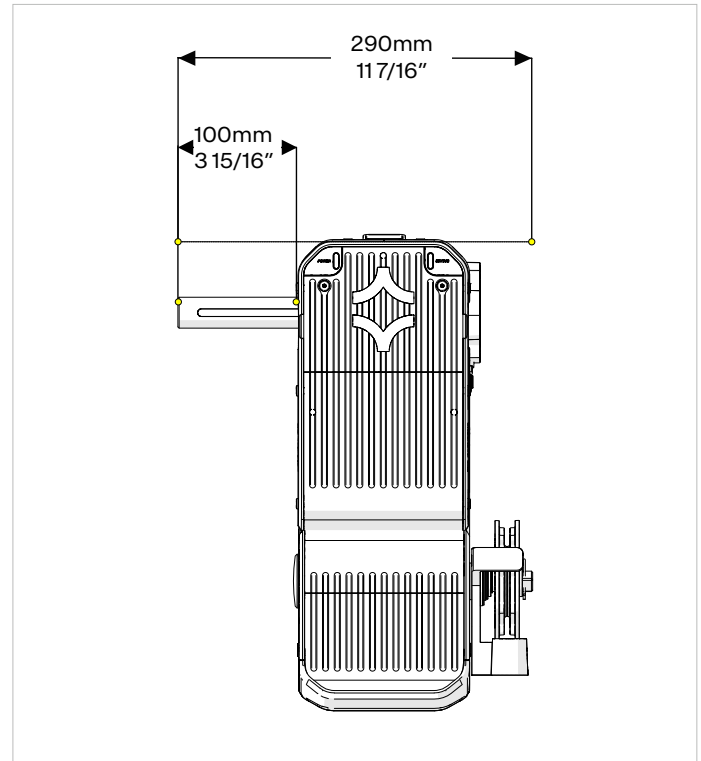
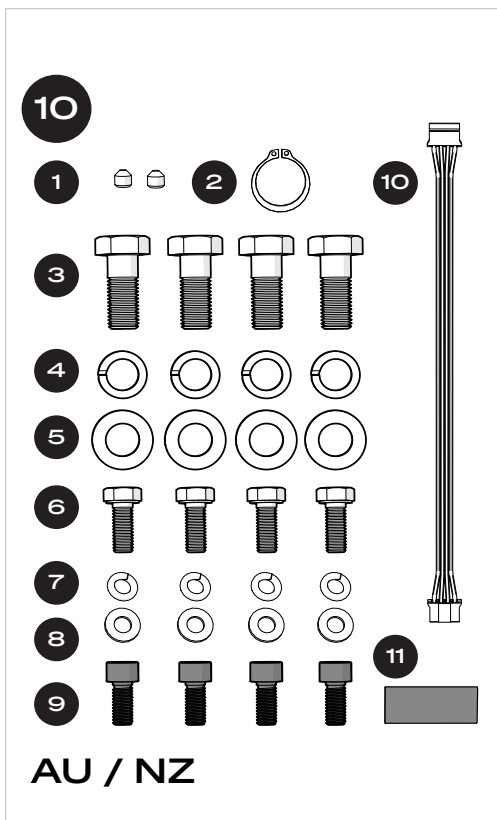
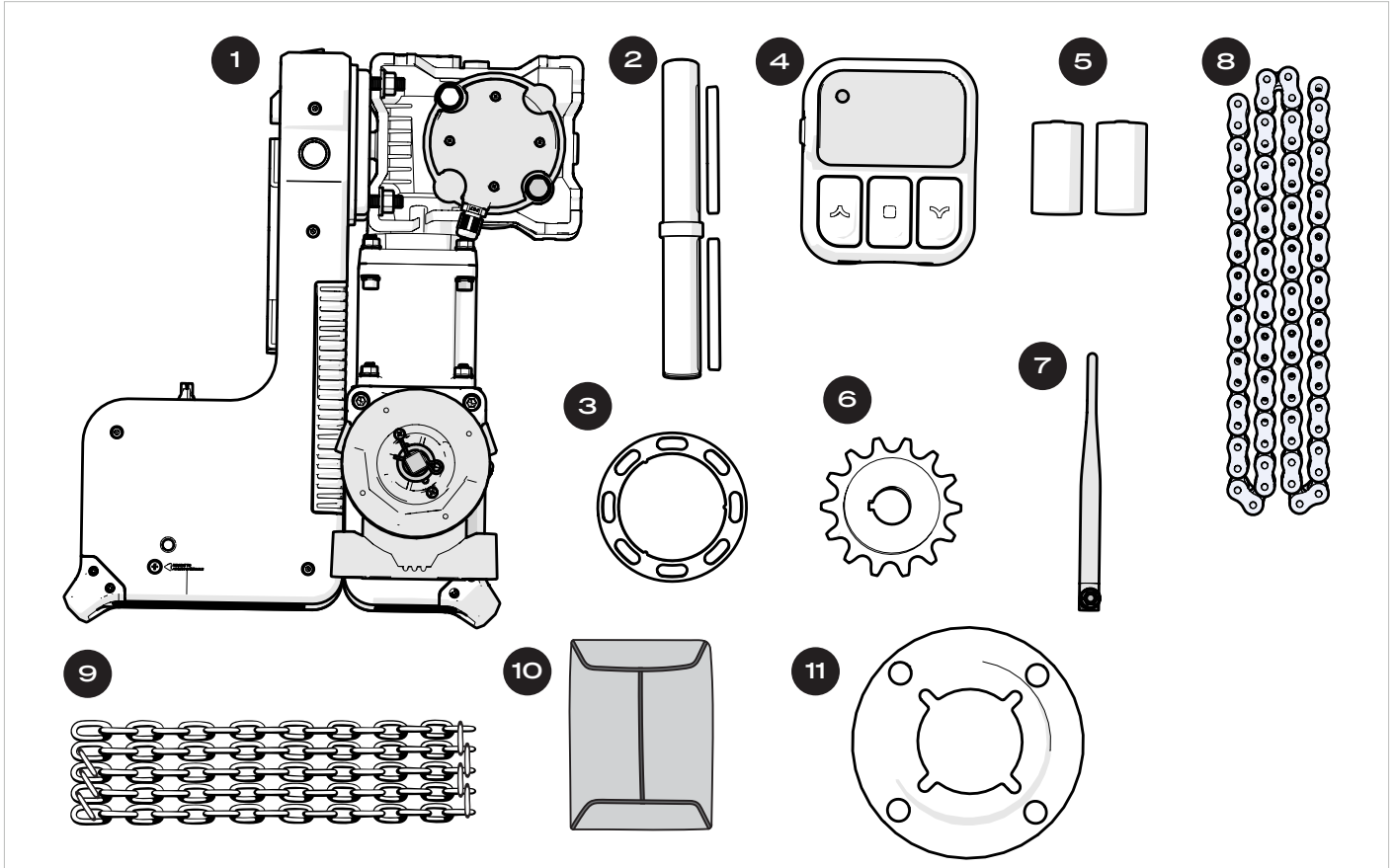

Fig:2 Front View

# Kit Contents

## PART NO. 101510 (AU/NZ)



### SOLD SEPARATELY

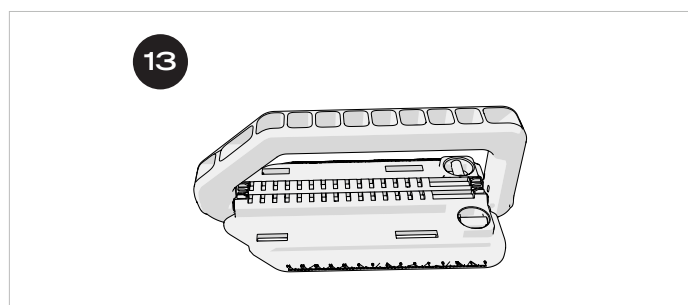
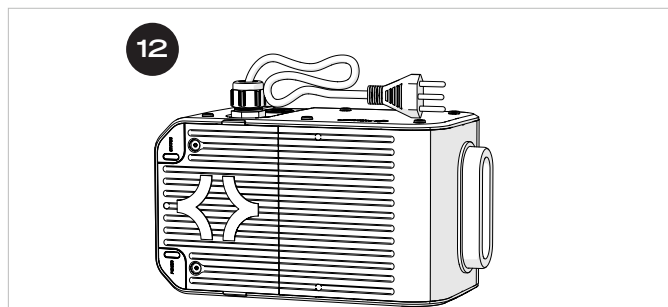

ITEM	DESCRIPTION	QTY
1	DRIVE UNIT	1
2	OUTPUT DRIVE SHAFT ASSEMBLY	1
3	MOUNTING BRACKET SPACER	1
4	WALL CONSOLE	1
5	D CELL ALKALINE BATTERIES (FITTED IN WALL CONSOLE)	2
6	SPROCKET 10B	
7	WIRELESS ANTENNA	1
8	DRIVE CHAIN 12T 10B	1
9	HAULING CHAIN (10M)	1
<b>10</b>	<b>ACCESSORIES ENVELOPE</b>	<b>1</b>
10/1	5/16" GRUB SCREWS FOR SPROCKET	2
10/2	CIRCLIP D0250 0120	1
10/3	HEX HEAD SCREW ZP M12 X 30	4
10/4	SPRING WASHER I.D.12	4
10/5	FLAT WASHER 12.2X30X2.5	4
106	HEX HEAD SCREW M8 X 20	4
10/7	SPRING WASHER I.D.8	4
10/8	FLAT WASHER I.D. 8	4
10/9	SOC HD SCREW M8 X 18	4
10/10	HARNESS FOR PE BEAM WIRELESS BASE STATION	1

ITEM	DESCRIPTION	QTY
10/11	SELF ADHESIVE HOOK & LOOP STRIP FOR WIRELESS BASE STATION	1
11	FLANGED MOUNTING ADAPTER (AU/ NZ ONLY)	1
<b>ITEMS SOLD SEPARATELY</b>		
12	OMNIVOLT® POWER CARTRIDGE - PART NO. 101640 (LOW VOLTAGE) & PART NO. 101642 (HIGH VOLTAGE)	
13	DAVE'S HANDLE - PART NO. 101931	

# Kit Contents

## PART NO. 101511 (NORTH AMERICA)

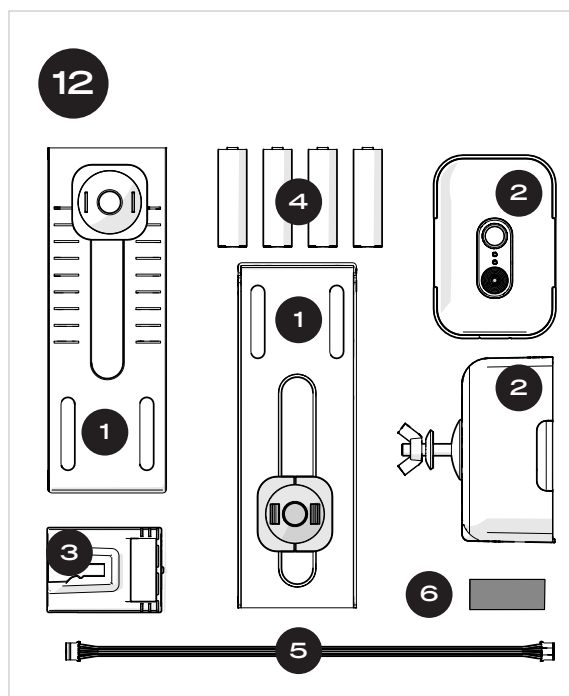
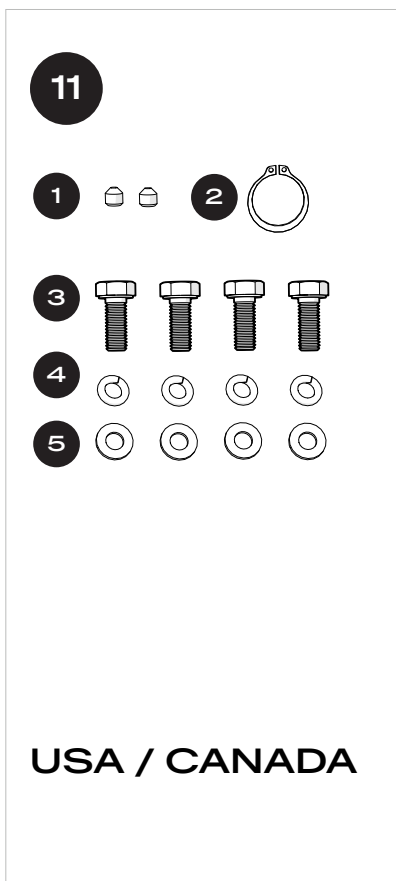
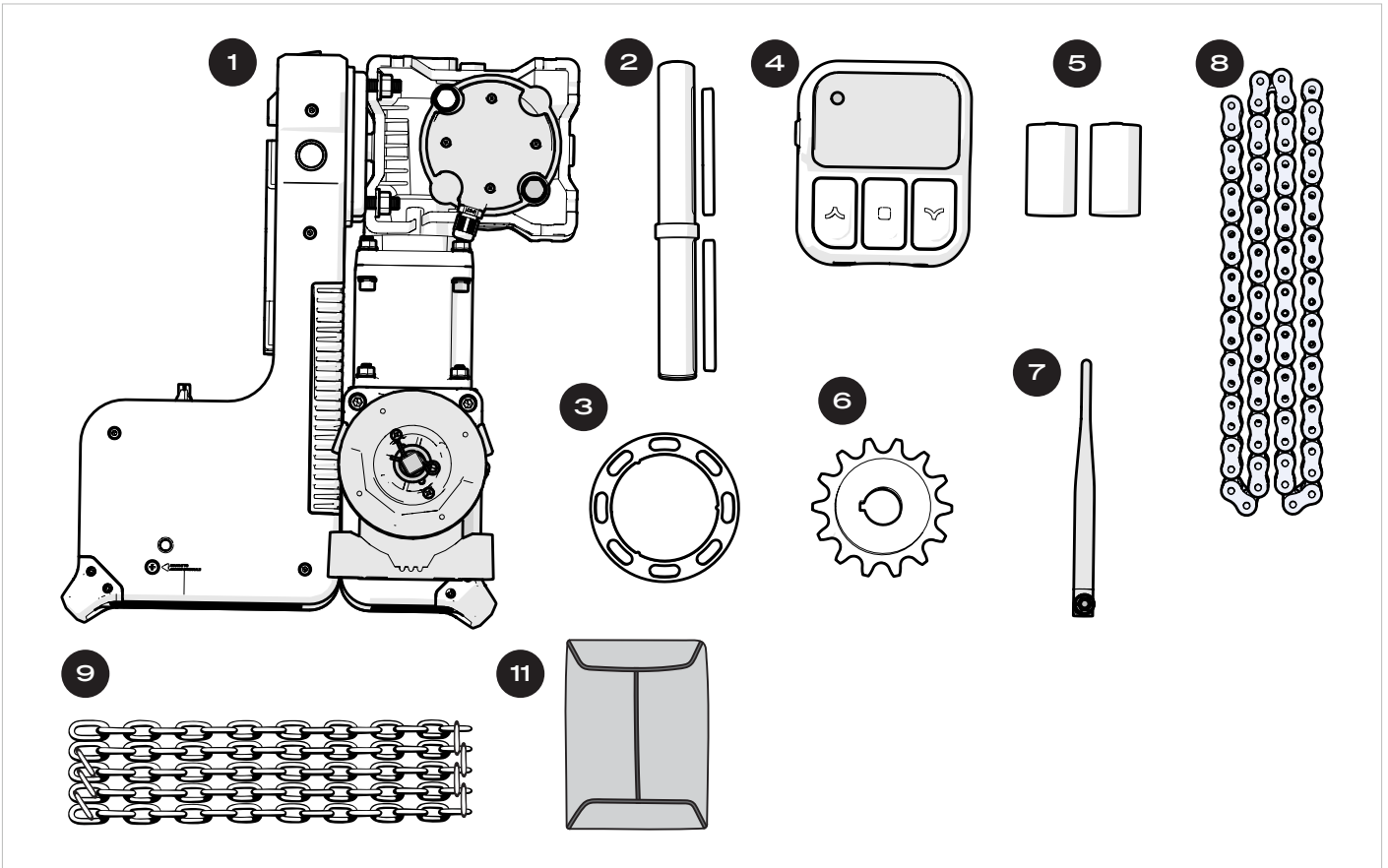

ITEM	DESCRIPTION	QTY
1	DRIVE UNIT	1
2	OUTPUT DRIVE SHAFT ASSEMBLY	1
3	MOUNTING BRACKET SPACER	1
4	WALL CONSOLE	1
5	D SIZE ALKALINE BATTERIES	2
6	SPROCKET #50	1
7	WIRELESS ANTENNA	1
8	DRIVE CHAIN 10B	1
9	HAULING CHAIN	1
11	ACCESSORIES ENVELOPE	1
11/1	5/16" SET SCREWS FOR SPROCKET	2
11/2	LOCK RING D0250 0120	1
11/3	HEX HEAD SCREW M8 X 20	4
11/4	LOCK WASHER I.D.8	4
11/5	FLAT WASHER I.D. 8	4

ITEM	DESCRIPTION	QTY
12	WIRELESS-FIRST SAFETY BEAM KIT FOR US ONLY	1
12/1	L BRACKET ASSEMBLY	2
12/2	TRANSMITTER / RECEIVER ASSEMBLY	2
12/3	WIRELESS BASE STATION	1
12/4	AA SIZE ALKALINE BATTERIES	4
12/5	WIRELESS BASE STATION HARNESS	1
12/6	SELF ADHESIVE HOOK & LOOP STRIP FOR WIRELESS BASE STATION	1
13	SAFETY PLACARDS	1

**POWER CARTRIDGE OPTIONS**

14	OMNIVOLT® POWER CARTRIDGE PART NO. 101641 (LOW VOLTAGE) & PART NO. 101642 (HIGH VOLTAGE)
15	DAVE'S HANDLE (PART NO. 101931)

**SOLD SEPARATELY**

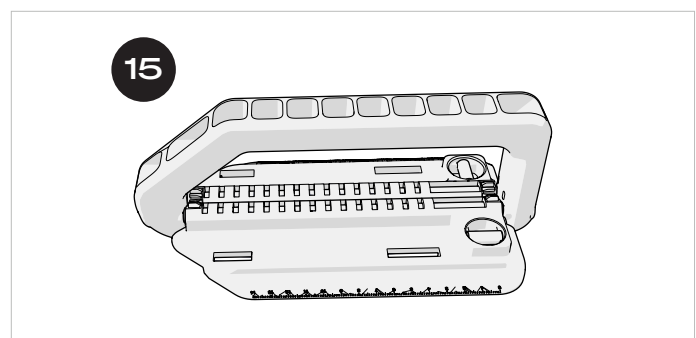
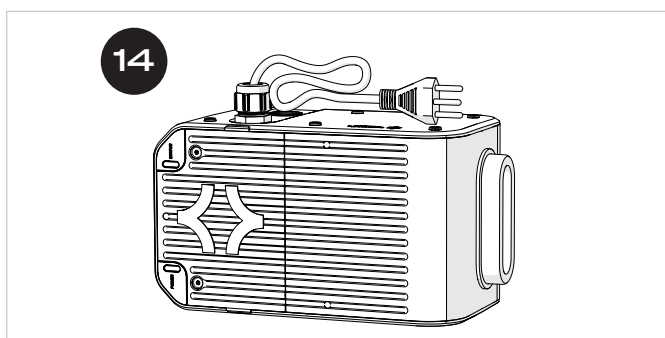

# Exploded Parts Diagrams

## FLANGED MOUNTING ADAPTOR CONFIGURATION (COMMON FOR AUSTRALIAN AND NEW ZEALAND ROLLER SHUTTER INSTALLATIONS)

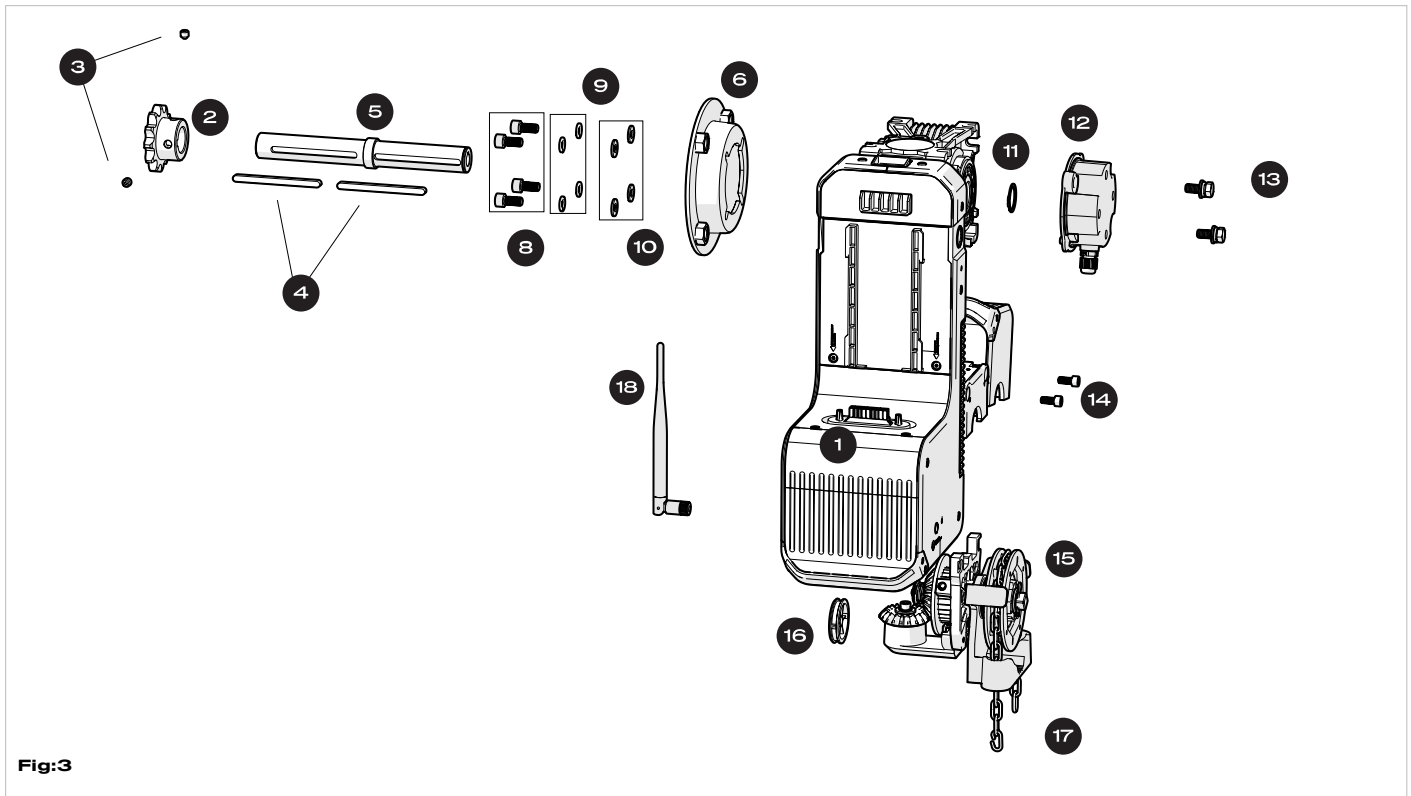

Fig:3

ITEM	DESCRIPTION	QTY	ITEM	DESCRIPTION	QTY
1	POWERHEAD	1	10	FLAT WASHERS	4
2	SPROCKET 10B (#50)	1	11	CIRCLIP (LOCK RING)	1
3	SPROCKET GRUB SCREWS (SET SCREWS)	2	12	SURETRACK™ POSITIONING ENCODER	1
4	DRIVE SHAFT KEYS	2	13	SURETRACK™ POSITIONING ENCODER SCREWS WITH CAPTIVE WASHERS	2
5	DRIVE SHAFT	1	14	HAULING CHAIN ASSEMBLY SCREWS	2
6	AU / NZ FLANGED MOUNTING ADAPTER (FIG:3 ONLY)	1	15	HAULING CHAIN ACCESS SLOT CAP	1
7	MOUNTING BRACKET SPACER (FIG:4 ONLY)	1	16	HAULING CHAIN ASSEMBLY	1
8	BLACK SOC HEAD SCREW M8X18	4	17	HAULING CHAIN	1
9	M8 SPRING WASHERS (LOCK WASHERS)	4	18	WIRELESS ANTENNA	1

# SECTIONAL AND HOOD MOUNT BRACKET CONFIGURATION WHEN USING HOOD MOUNT AND WALL MOUNT BRACKET KITS (COMMON IN NORTH AMERICA)

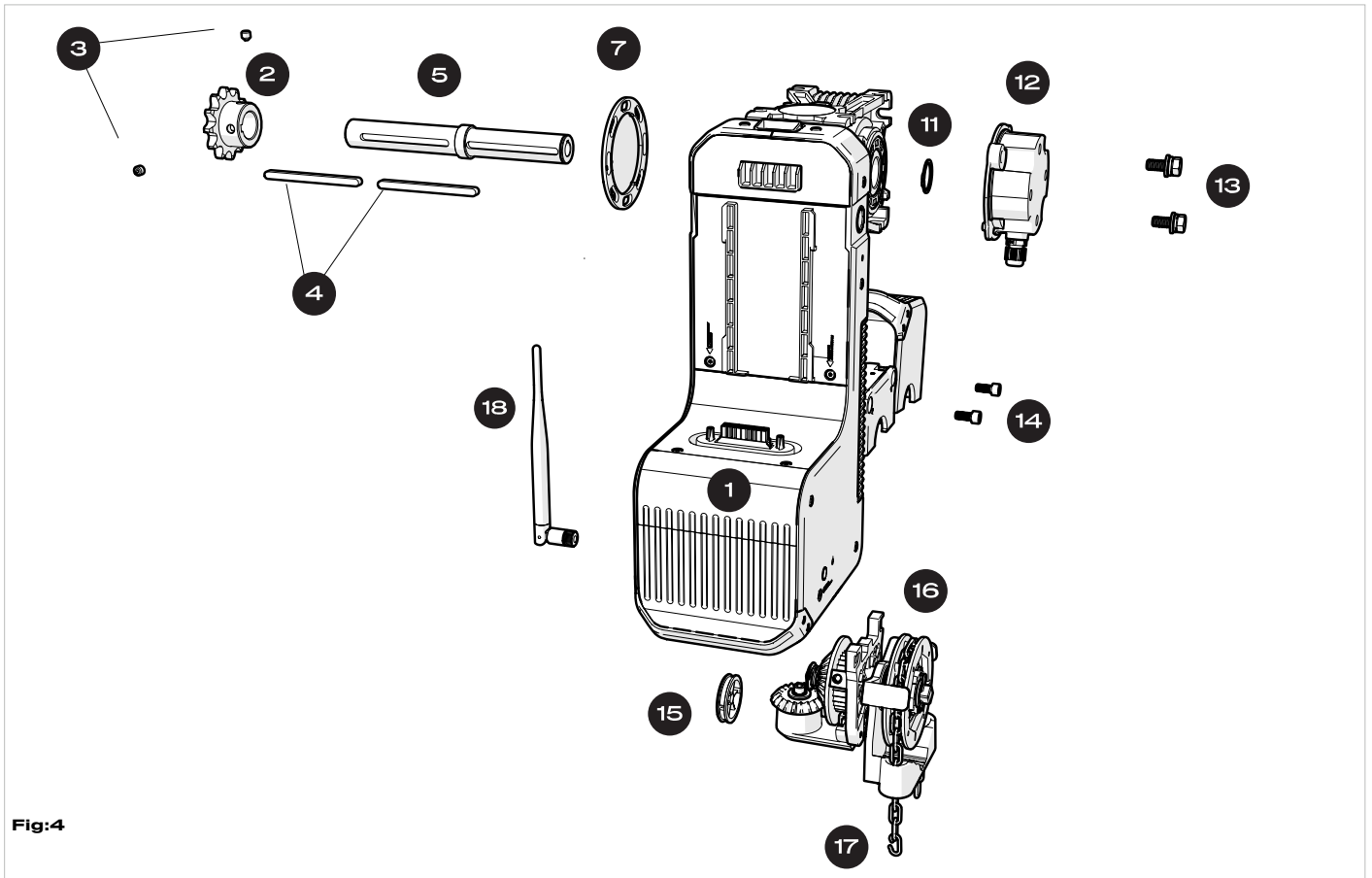

Fig:4



# Mounting Hardware Explained

WHEN USING WITH FLANGED MOUNTING ADAPTOR (COMMON FOR AUSTRALIAN AND NEW ZEALAND ROLLER SHUTTER INSTALLATIONS)

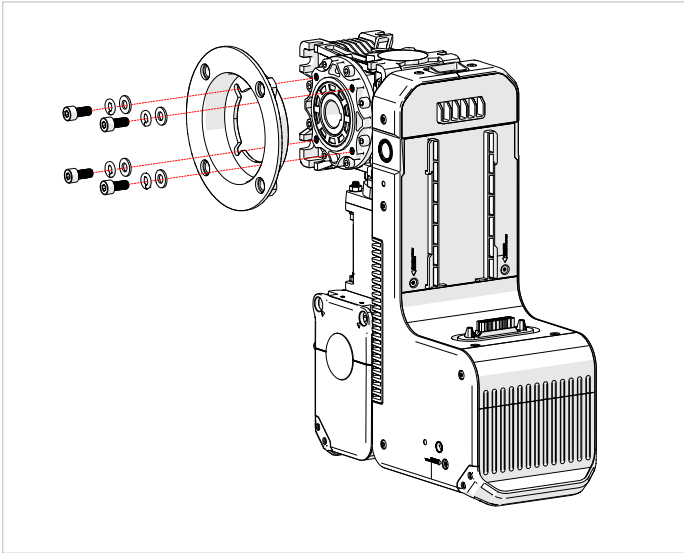

Fig:5

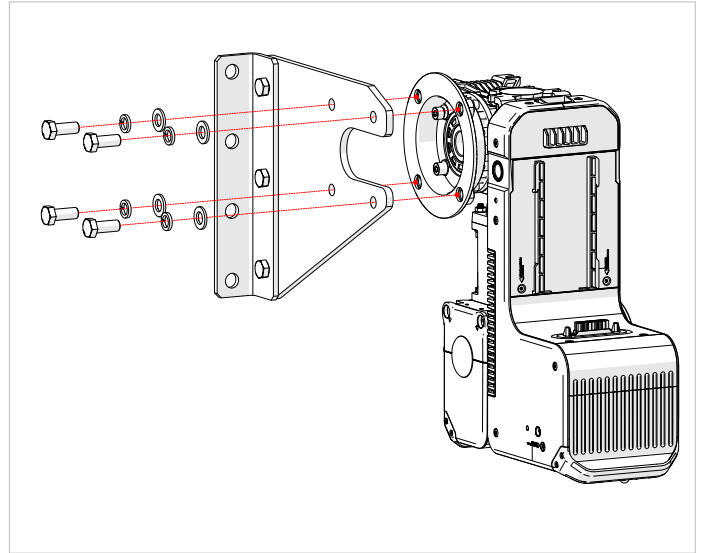

Fig:6

## For Part No. 101510

PART / PART SET	QTY	WHERE TO USE
5/16" GRUB SCREWS	2	Secures the supplied 10B drive sprocket.
CIRCLIP D0250 0120	1	Required for installing the output drive shaft assembly (including handing change)
HEX HEAD SCREW ZP M12 X 30	4	Fastens the supplied flange adaptor to a new or existing third-party roller shutter flag bracket Fig:6.
SPRING WASHER I.D. 12	4	
FLAT WASHER 12.2 X 30 X 2.5	4	
BLACK SOC HEAD SCREW ZP M8 X 18	4	<b>FOR ROLLER SHUTTER ROLLING DOOR INSTALLS</b> Fastens the supplied flange adaptor to the reducer (gearbox) for roller shutter installs Fig:5.
SPRING WASHER I.D. 8	4	
FLAT WASHER I.D. 8	4	
HEX HEAD SCREW M8 X 20	4	<b>FOR SECTIONAL DOOR INSTALLS USING SECTIONAL BRACKET KIT ACCESSORY</b> Secures the mounting bracket spacer to the reducer (gearbox) for sectional door installs Fig:8.
SPRING WASHER I.D. 8	4	
FLAT WASHER I.D. 8	4	

**SECTIONAL AND HOOD MOUNT BRACKET CONFIGURATION WHEN USING HOOD MOUNT AND WALL MOUNT BRACKET KITS (COMMON IN NORTH AMERICA)**

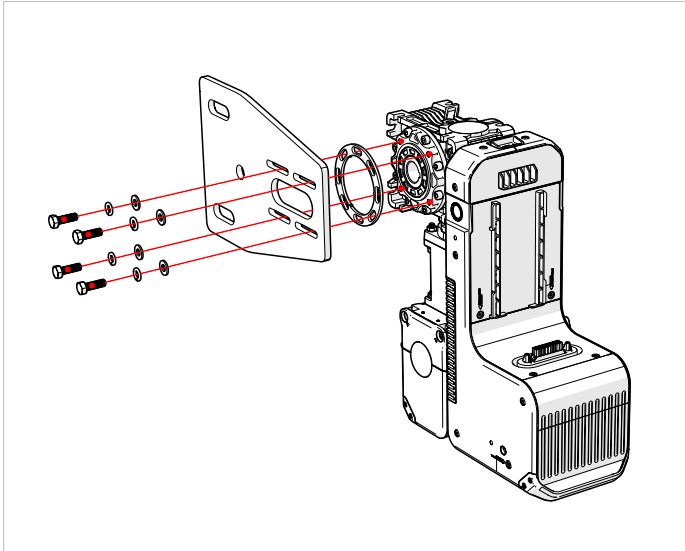

Fig:7

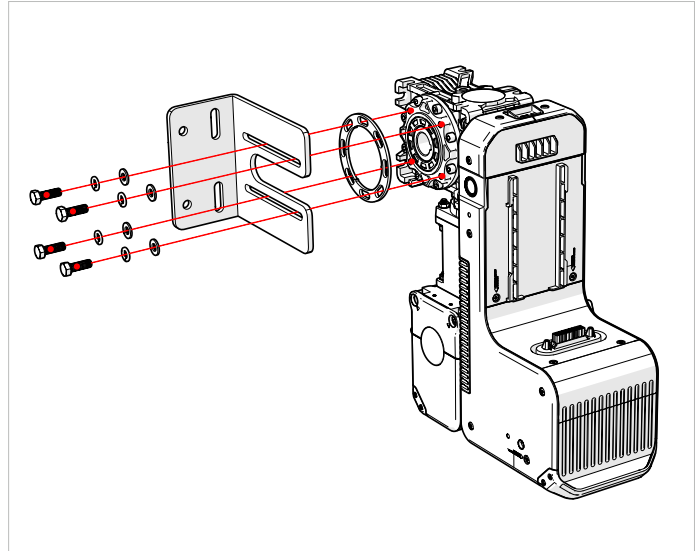

Fig:8

**For Part No. 101511**

PART / PART SET	QTY	WHERE TO USE
5/16" SET SCREWS	2	Secures the supplied 10B or #50 drive sprocket.
LOCK RING D0250 0120	1	Required for installing the output drive shaft assembly (including handing change)
HEX HEAD SCREW M8 X 20	4	<b>FOR SECTIONAL AND HOOD MOUNT DOOR INSTALLS USING WALL AND HOOD MOUNT BRACKET KIT ACCESSORIES</b>
LOCK WASHER I.D. 8	4	Secures the mounting bracket spacer to the reducer (gearbox) for sectional and hood mount door installs Fig:7 - Fig:8.
FLAT WASHER I.D. 8	4	

**CORRECT WASHER ORDER ON BOLT: LOCK / SPRING FIRST, FLAT SECOND**

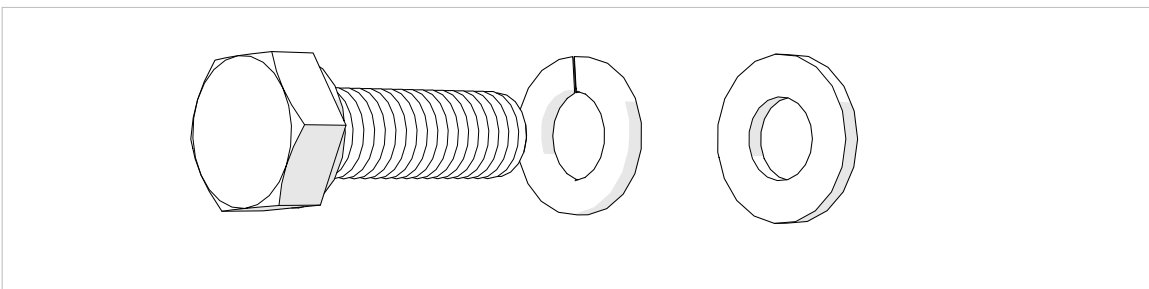

Fig:9

## **3. CONFIGURING OPERATOR DRIVE SHAFT & HANDING**

# Drive Shaft

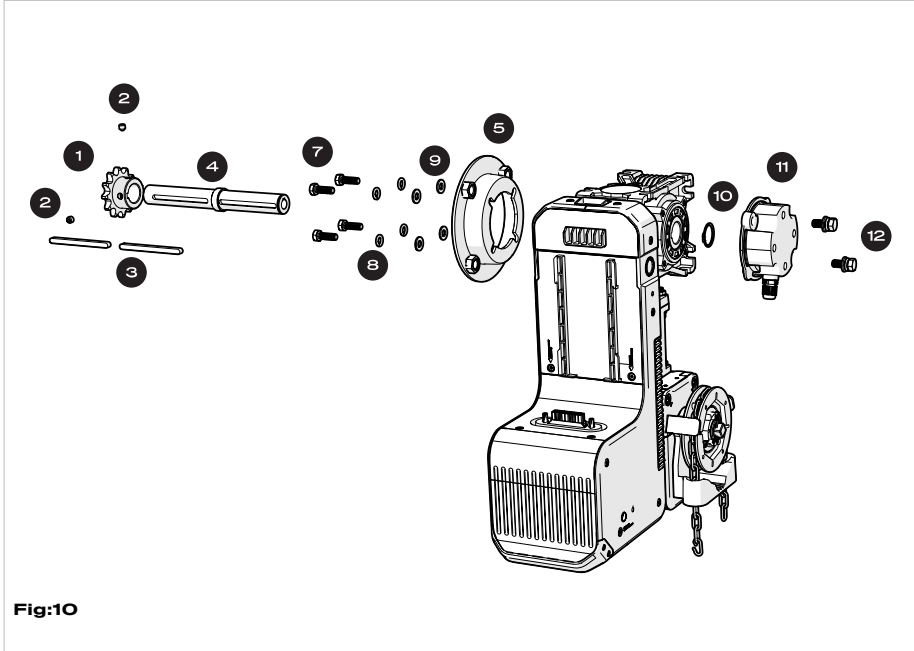

Fig:10

Right Hand Drive Assembly for Roller Shutter using Flanged Mounting Adaptor: Exploded view of drive shaft encoder and positioning encoder arranged for right-hand positioning of the operator (looking from inside the building outwards).

1. Unscrew SureTrack™ positioning encoder
2. Assemble drive shaft to required handing (Left / Right), making sure to include the shaft key at the reducer end.
3. Attach circlip (lock-ring) to secure drive shaft.
4. Align SureTrack™ positioning encoder shaft key to interior shaft key-way in drive shaft adaptor.
5. Assemble SureTrack™ positioning encoder to opposite side of drive shaft.
6. Assemble sprocket and key onto drive shaft. Hand-tighten sprocket grub (set) screws, allowing a slight give. This will need to be removed and reattached when mounting.
7. Do not attach operator to mounting bracket or flanged adaptor until the bracket has been fixed to substrate.

## DRIVE ASSEMBLY REVERSIBLE PARTS KEY

1. Sprocket
2. Sprocket Grub Screws x 2
3. Drive Shaft Keys
4. Drive Shaft
5. Mounting Adaptor (AU/NZ Only)
6. Mounting Bracket Spacer (Do not use with AU/NZ Mounting Adaptor)
7. M8x20 Black Socket Head Screws
8. M8 Spring Washers (Lock Washers) x 4
9. M8 Flat Washers x 4
10. Circlip (Lock Ring)
11. SureTrack™ positioning encoder
12. SureTrack™ positioning encoder Screws and captive washers (M8x18) x 2

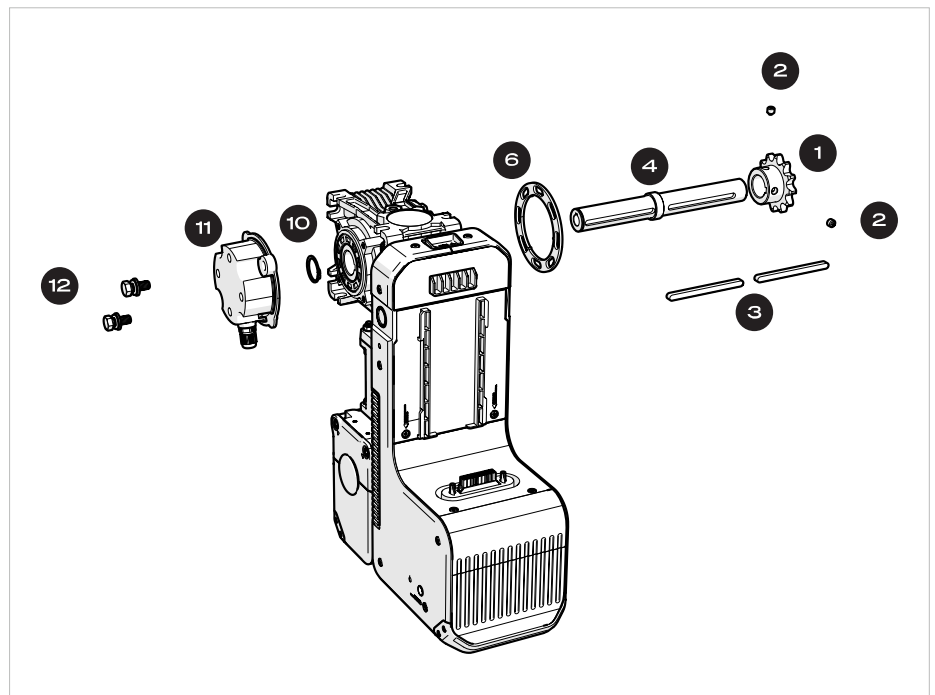

Fig:11

Left Hand Drive Assembly for Sectional and Hood Mounts Exploded view of drive and timing components arranged for left-hand positioning of the operator (looking from inside the building outwards).

# Manual Hauling Chain

1. Unclip and hinge open the hauling chain assembly cover.
2. Slide out the cap from the unused hauling gear access slot.
3. Unfasten the hauling chain gear by removing the hex bolts and lifting out the assembly.
4. Note the microswitch cable that connects the hauling chain assembly to the drive unit. Take care not to tangle or break this while changing the hauling chain assembly position.
5. Switch the cap and hauling chain assembly into the opposite slots and refasten the hex bolts.
6. Close the assembly chain cover, making sure it has clipped shut securely.

## Warning

- To avoid accidental entanglement of the hauling chain with the drive mechanism, it is strongly recommended to position the manual hauling chain on the opposite side of the operator to the drive sprocket. Failure to do so may result in serious injury and permanent damage to the operator.

## AVERTISSEMENT

- Pour éviter tout risque d'enchevêtrement accidentel de la chaîne de manœuvre avec le mécanisme d'entraînement, il est fortement recommandé de positionner la chaîne de manœuvre manuelle du côté opposé à celui du pignon d'entraînement. Le non-respect de cette consigne peut entraîner des blessures graves et des dommages permanents à l'opérateur.

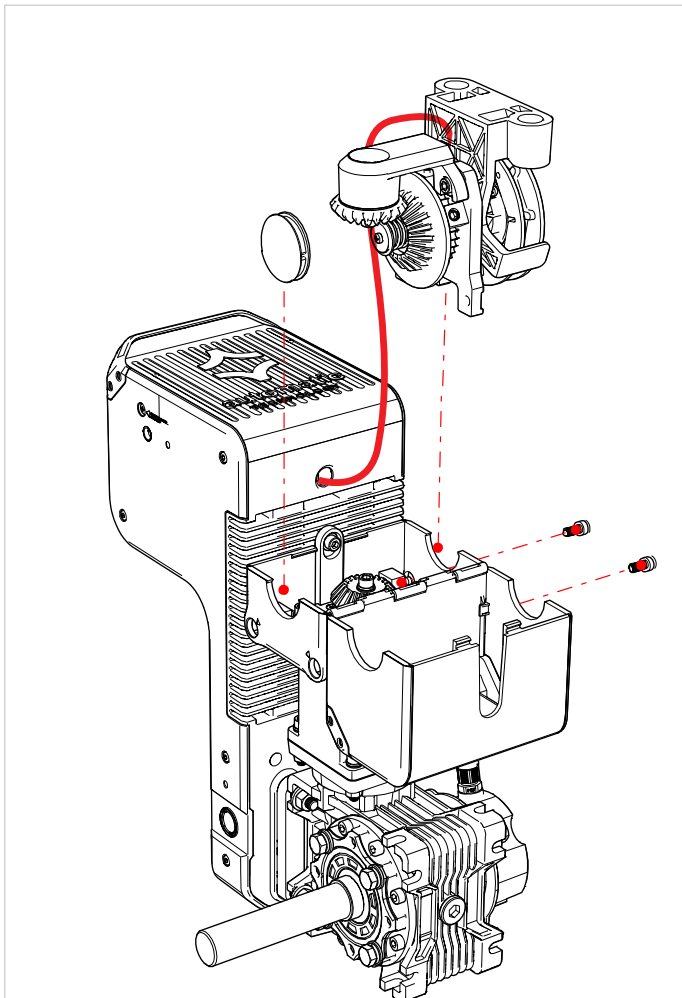

Changing Side of Hauling Chain Assembly

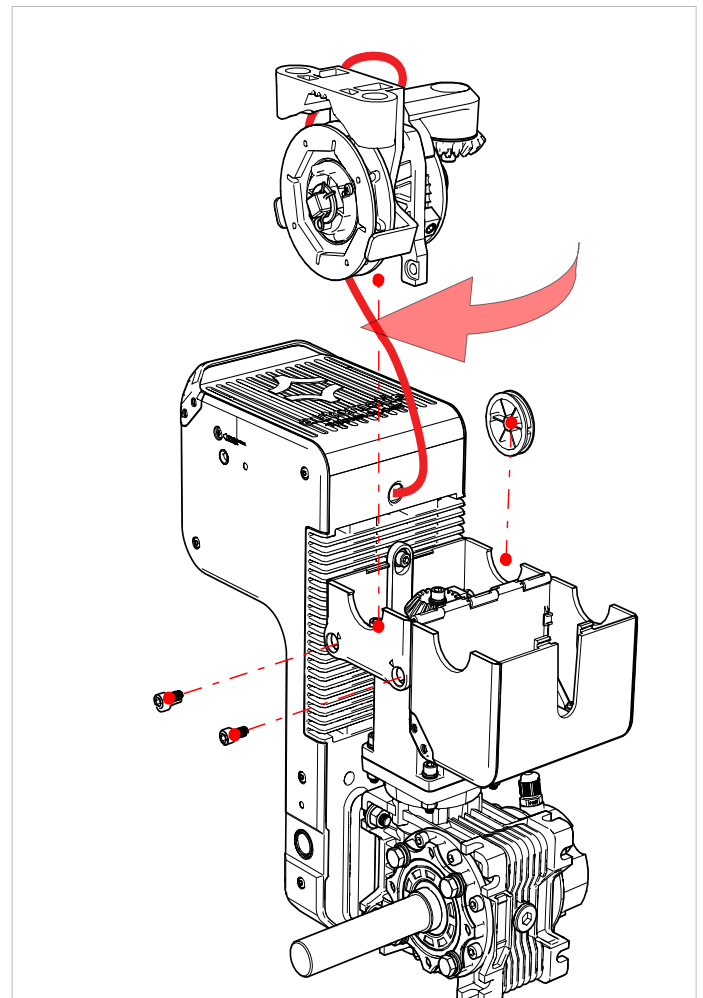

## 4. INSTALLATION

# Important Installation Instructions



## WARNING

### TO REDUCE THE RISK OF SEVERE INJURY OR DEATH:

- a. **READ AND FOLLOW ALL INSTALLATION INSTRUCTIONS.**
- b. Install only on a properly balanced garage door. A door that is operating improperly could cause severe injury. Have qualified service personnel make repairs to cables, spring assemblies, and other hardware before installing the operator.
- c. Remove all pull ropes and remove, or make inoperative, all door locks (if any) that will interfere with operation of the door connected to the door before installing the operator.
- d. A commercial/industrial door operator that has exposed moving parts capable of causing injury to persons or damage to property shall be located or guarded so as to avoid hazards, in accordance with UL 325 requirements.
- e. If the operator must be installed less than 2.44m (8 ft) above the floor, then exposed moving parts must be protected by guarding to avoid hazards.
- f. Locate the control button:
  - i. Within sight of the door,
  - ii. At a minimum height of 1.53m (5 ft) above the floor so small children are not able to operate it, and
  - iii. Away from all moving parts of the door.
- g. All warning signs and placards must be installed where visible in the area of the door
- h. **Install the Entrapment Warning Placard next to the control button in a prominent location. The placard is included in the literature pack. Placard must be installed at least 1.53 m (5 ft) above floor level (UL 325/CSA requirement)**
- i. After installing the operator, the door must reverse when it contacts a 38-mm (1-1/2 in.) high object or a 2 x 4 board laid flat on the floor.
- j. **SAVE THESE INSTRUCTIONS.**

# Instructions d'installation importantes



## AVERTISSEMENT

### POUR RÉDUIRE LES RISQUES DE BLESSURES GRAVES OU DE MORT :

- a. **LISEZ ET SUIVEZ TOUTES LES INSTRUCTIONS D'INSTALLATION.**
- b. N'installez l'ouvre-porte que sur une porte de garage correctement équilibrée. Une porte qui fonctionne mal peut causer des blessures graves. Faites réparer les câbles, les ressorts et tout autre composant par un technicien qualifié avant d'installer l'opérateur.
- c. Enlevez toutes les cordes de tirage et retirez ou rendez inopérants tous les verrous de porte (le cas échéant) qui pourraient gêner le fonctionnement de la porte avant d'installer l'opérateur.
- d. Un opérateur de porte commerciale/industrielle comportant des pièces mobiles exposées susceptibles de causer des blessures ou des dommages doit être installé ou protégé de façon à éviter tout danger, conformément aux exigences UL 325.
- e. Si l'opérateur doit être installé à moins de 2,44 m (8 pi) du sol, les pièces mobiles exposées doivent être protégées par un dispositif de protection pour éviter tout danger.
- f. Placez le bouton de commande:
  - i. à un endroit d'où la porte est visible,
  - ii. à une hauteur minimale de 1,53 m (5 pi) du sol afin que les jeunes enfants ne puissent pas l'atteindre,
  - iii. à l'écart de toutes les pièces mobiles de la porte.
- g. Tous les panneaux et plaquettes d'avertissement doivent être installés à un endroit bien visible dans la zone de la porte.
- h. **Installez la plaquette d'avertissement contre le happement à côté du bouton de commande, à un endroit bien en vue. La plaquette est incluse dans le kit de documentation. Elle doit être installée à au moins 1,53 m (5 pi) du sol (exigence UL 325/CSA).**
- i. Après l'installation de l'opérateur, la porte doit inverser son mouvement lorsqu'elle entre en contact avec un objet de 38 mm (1-1/2 po) de hauteur ou une planche de 2 x 4 posée à plat sur le sol.
- j. **CONSERVEZ CES INSTRUCTIONS.**

# Get a Load of DAVE's Flexibility!

---

DAVE is incredibly versatile and can handle just about any commercial or industrial door type or installation style.

Just a few minutes of pre-planning will mean you can take full advantage of DAVE's time-saving installation benefits.

## Wireless or Wired? you choose!

Unless you really love wires, we suggest you opt for a wireless set up.

Compatible Automatic Technology safety beams and DAVE's Wall Console both deliver reliable, long lasting performance via standard alkaline batteries. Alternatively, they can draw power from DAVE itself, or if preferred, the console can even be powered by an independent 5V DC power supply.

## Orientation

DAVE can be installed in any orientation, vertically, horizontally, or even upside-down.

## Power

To take advantage of pre-wired power cartridge cable, requires a standard electrical wall outlet located within 1 meter (3 feet) of the drive unit. Alternatively, the power cartridge can be hardwired into the mains by a qualified electrician.

## Mandatory Safety device Requirement

A safety device must be connected to the operator and positioned as close to the door's travel path as possible.

Note: this operator must have at least one safety device connected in order to function without constant contact (dead-man) mode.



# Installation Setup Options

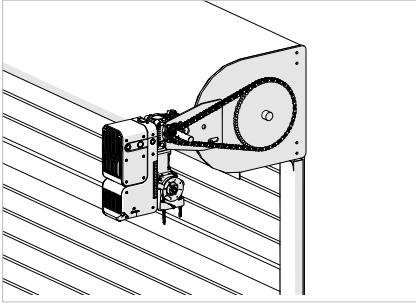

Right Hand Vertical Hood Mount Rolling Steel

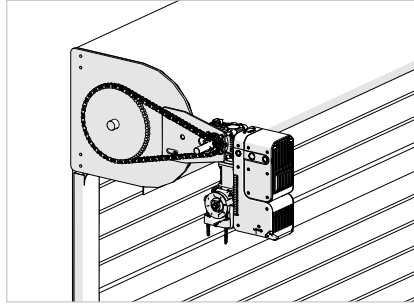

Left Hand Vertical Hood Mount Rolling Steel

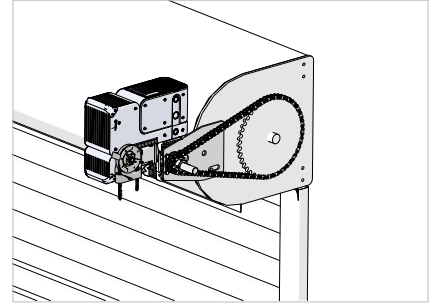

Right Hand Horizontal Hood Mount Rolling Steel

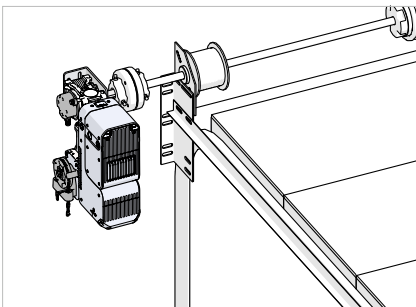

Left Hand Direct Coupled Sectional

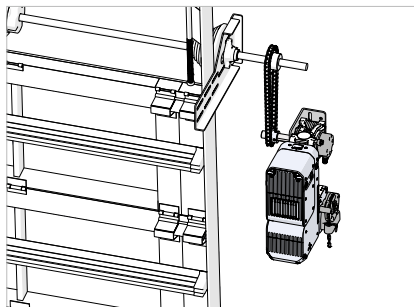

Right Hand Sprocket to Sprocket / Jack Shaft Vertical Lift

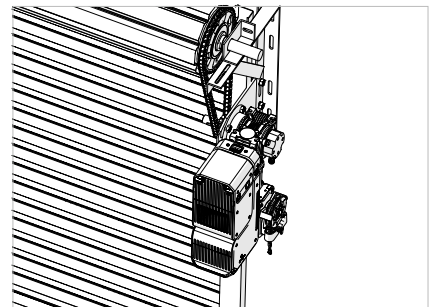

Right Hand Fixed Axle Sprocket to Sprocket Roller Shutter

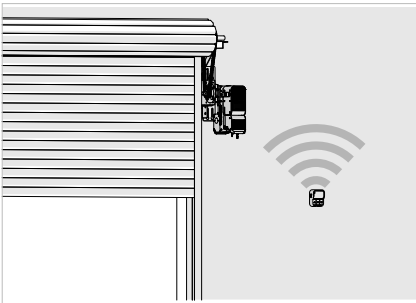

Battery Powered Wireless Console

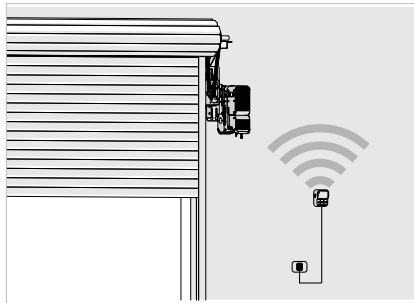

5VDC Mains Powered Wireless Console

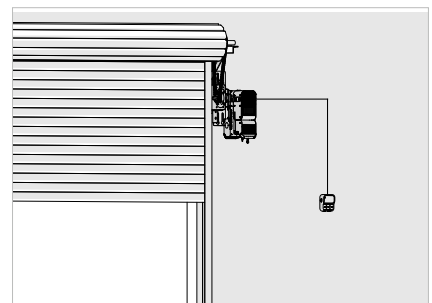

Operator Powered Wired Console

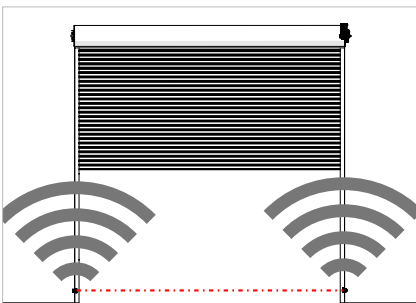

Battery Powered Wireless Safety Beam

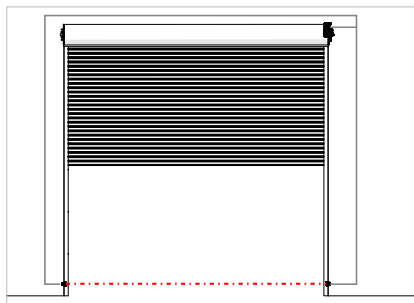

Wired Safety Beam

# Step by Step Installation Sequence



**DANGER - INCORRECT INSTALLATION CAN LEAD TO SEVERE INJURY OR DEATH. FOLLOW ALL INSTALLATION INSTRUCTIONS.**



**DANGER - UNE INSTALLATION INCORRECTE PEUT ENTRAÎNER DES BLESSURES GRAVES OU LA MORT. SUIVEZ TOUTES LES INSTRUCTIONS D'INSTALLATION.**

## Pre-Installation Planning

- 1. Identify door type and mounting hardware**
  - Determine if the door is sectional, rolling steel, or shutter.
  - Choose appropriate mounting brackets and adaptors.
- 2. Check door condition and balance**
  - Ensure the door can travel freely in the guides for the full travel distance in both directions, and is in good working order.
  - Clamp it securely to prevent movement during installation.
- 3. Confirm installation side and orientation**
  - Choose left or right side.
  - DAVE can be mounted vertically, or horizontally.
- 4. Verify mounting surface**
  - Ensure the wall or structure is solid (concrete, brick, or steel) and can support the full force applied to the door..
- 5. Check clearances**
  - Maintain at least 10 mm (½") between the drive unit and any structure.
  - Overhead clearance should be at least 150 mm (6")

# Mechanical Installation



## WARNING

When mounting the operator bracket make sure to use fasteners that are suitable for the substrate (e.g. concrete, brick, steel, timber). Bracket mounting fasteners are not supplied.



## AVERTISSEMENT

Lors de la fixation du support de l'opérateur, utilisez des fixations adaptées au matériau de support (par exemple : béton, brique, acier, bois). Les fixations pour le montage du support ne sont pas fournies.

### 6. Assemble drive shaft to desired handedness

- Unscrew the SureTrack™ positioning encoder, fit shaft for left or right-hand drive as required, attach circlip, and re-attach the positioning encoder - see *Output Shaft on page 21*.

### 7. Move up to operator mounting level

- Ensure you have safe access to the mounting level and enough space to work.
- Take all required tools, hardware, and components with you before starting bracket installation.

### 8. Position and fix the mounting bracket

- Select a bracket suitable for the door type and installation style - see *Available Brackets on page 31*.
- Secure the bracket to a solid surface, ensuring correct alignment for the drive unit.
- When mounting the opener and its accessories, use the correct bracket mounting fasteners for the specific wall or structure material. (Bracket mounting fasteners are not supplied).

### 9. Attach DAVE's installation handle

- We recommend using DAVE's installation handle to make mounting easier and safer - see *DAVE's Handle on page 30*.
- It provides better grip and control during installation and can be removed once the operator is secured.

### 10. Mount the operator to the bracket

- Secure the operator firmly to the bracket using the supplied hardware.
- Ensure the operator is correctly aligned and stable before proceeding.

### 11. Fit the drive connection

Depending on the installation type, choose one of the following:

#### 1. Sprocket-to-sprocket drive:

- Fit the drive sprocket to the shaft and align it with the door gear.
- Tighten the grub screws securely.
- Shorten the drive chain as required and fit it securely around the drive sprocket and door sprocket.

#### 2. Direct coupling:

- Fix the coupling directly to the shaft and door gear.

### 12. Fit the hauling chain

- Feed the hauling chain through the guide and over the chain wheel.
- Shorten as needed and ensure it is not twisted.
- Fix the ends together to form a secure loop using the chain joiner link.

### 13. Remove DAVE's installation handle

- Once the operator is mounted and secured, remove the handle - see *Connecting OmniVolt® Power Cartridge on page 43*



#### IMPORTANT TECH NOTE

For sprocket drive installations, ensure the sprocket GRUB SCREWS (SET SCREWS) are adequately tightened and checked regularly.



#### NOTE TECHNIQUE IMPORTANTE

Pour les installations avec entraînement par pignon, assurez-vous que les VIS SANS TÊTE du pignon sont correctement serrées et vérifiées régulièrement.

# Connect Wall Console

COMPLETE THIS STEP AT OPERATOR MOUNTING LEVEL

## 14. Set up the wall console for either wireless or wired connection

The wall console supports both wireless and wired installation.

Installers must select one connection method and follow the appropriate steps:

### 1. Wireless connection (recommended):

- Attach the wireless antenna to the side antenna port on the drive unit .
- It is strongly recommended to use the supplied console batteries during installation.

### 2. Wired connection:

- Connect the console using the Wall Console Wiring Kit (Part No. 102189, sold separately) - see *Connecting Console to Operator By Cable* on page 37.



If using a wired connection between console and operator, do not turn the power on to the operator before connecting the console.



Si vous utilisez une connexion filaire entre la console et l'opérateur, ne mettez pas l'opérateur sous tension avant d'avoir connecté la console.



When using a wired connection for the wall console, ensure that the wall console wiring cable is affixed properly and away from the moving parts of the door and operator.



Lorsque vous utilisez une connexion filaire pour la console murale, assurez-vous que le câble de la console murale est correctement fixé et éloigné des pièces mobiles de la porte et de l'opérateur.

# Install Accessories

COMPLETE THIS STEP AT OPERATOR MOUNTING LEVEL

## 15. Install any required or optional accessories

Accessories include :

- PE Beam (photoelectric safety beam) - see *Safety Device Setup on page 72*
- Light Curtain - see *LIGHT CURTAINS on page 76*
- Fire Alarm / Smoke Baffle - see *Fire System Input on page 77*
- Optional Relay Module
- Other compatible safety or control devices- see *Wiring Other Devices on page 85*

# Power Connection

COMPLETE THIS STEP AT OPERATOR MOUNTING LEVEL

## 16. Install the appropriate power cartridge

- See *OmniVolt® Power Cartridge Details on page 42*
- Use the correct cartridge for the installation type.
- Ensure the power source is within reach or arrange for hardwiring by a qualified electrician.

## 17. Connect power to the operator

- Plug in the power cartridge or complete hardwiring.
- Turn on power once all connections are secure.

# Ground-Level Setup

## 18. Move to ground level

- Relocate to ground level to complete wall console installation and system setup.

## 19. Mount the wall console to the wall

- Choose a suitable location that is easily accessible and visible to users.
- Mount the console securely using appropriate fasteners for the wall material - see *Mount Console to Wall with Appropriate Fasteners and Insert Batteries on page 35*
- Ensure the console is level and positioned at a comfortable operating height.

## 20. Program Operator via Wall Console

- Use the wall console to complete setup - see *Setting Limits on page 56*
- Select door type
- Set close and open limits
- Adjust door speed
- Add remote controls
- Set pedestrian position
- Set smoke baffle position
- Configure safety beam behaviour
- Personalise additional functions



Typical setup with wireless console connection

# Drive Unit

## DAVE's Handle

DAVE's handle is made for installers. Use it on every job, again and again. It's designed so you can lift and carry DAVE one-handed. It makes installing quick and clean, no stuffing about.

### 1. Fitting the Handle

Align the bottom locking tabs on the handle's base with the upper locking tabs on the DAVE'S mounting tracks (Fig:12) and slide the handle down as far as it will go.

### 2. Before lifting Dave, make sure the handle is securely attached.

Listen for a strong click as the locking latch snaps into place and pull back on the handle firmly to confirm it is locked and ready (Fig:15).

### 3. Removing the Handle

Once you've mounted DAVE securely into place, you can go ahead and remove the handle.

Push the locking latch away from the handle to release (Fig 6). Then slide the handle upwards until the locking tabs are free from the mounting rail and lift it off.

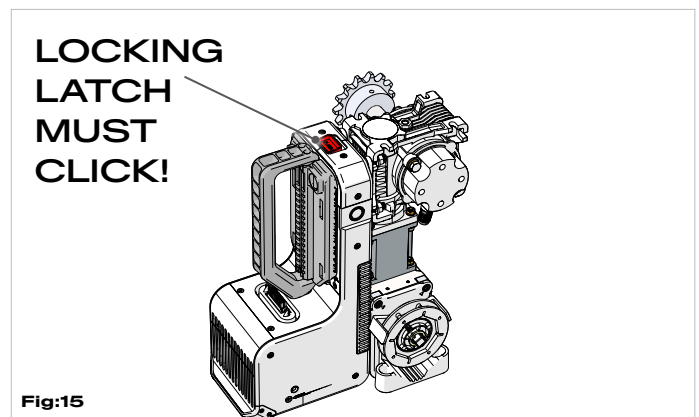
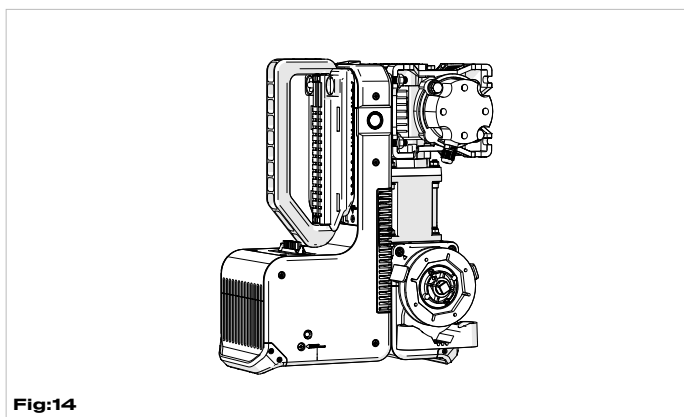
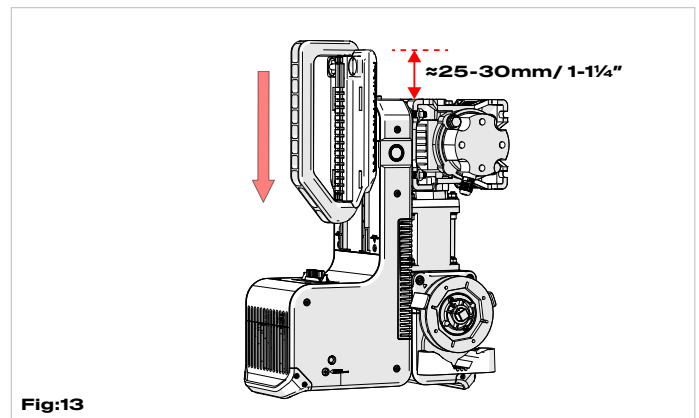
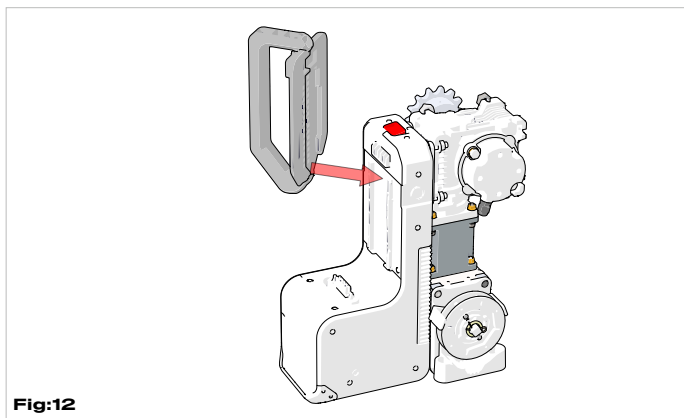



**! WARNING**

If the latch doesn't click, the handle may detach during lifting.

**! AVERTISSEMENT**

Si le loquet ne s'enclenche pas, la poignée peut se détacher pendant la levée.

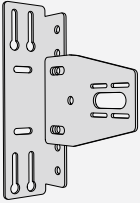
# Available Brackets

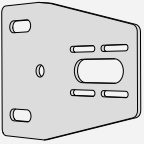
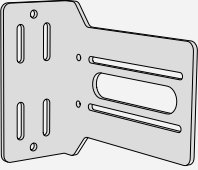
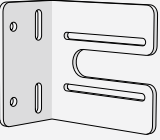
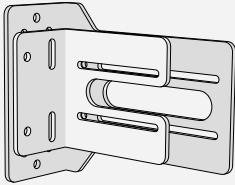
Bracket Name	Door Type	Install Type	Cable Drum Diameter	Image
Hood Mount Bracket Kit + Multifit Wall Mount Bracket Kit Assembly Part No. 101919 & 101900	Rolling Steel, Roller Shutter, Overhead Door	<ul style="list-style-type: none"> <li>• Sprocket to Sprocket,</li> <li>• Heavy Duty mounting option,</li> <li>• Load spreading for poor substrate,</li> <li>• Retrofit to existing operator mounting footprint</li> </ul>	N/A	
Multifit Wall Mount Bracket Kit Part No. 101919	Rolling Steel, Roller Shutter	<ul style="list-style-type: none"> <li>• Sprocket to Sprocket,</li> <li>• Heavy Duty mounting option,</li> <li>• Load spreading for poor substrate,</li> <li>• Retrofit to existing operator mounting footprint</li> </ul>	N/A	
Hood Mount Bracket Kit Part No. 101900	Rolling Steel, Roller Shutter,	<ul style="list-style-type: none"> <li>• Sprocket to Sprocket</li> </ul>	N/A	
Wall Mount Bracket Kit (long bracket only) Part No. 101910	Sectional, Overhead Door, Vertical Lift, High Lift	<ul style="list-style-type: none"> <li>• Direct Shaft Coupling</li> <li>• Sprocket to Sprocket</li> </ul>	6"-14"	
Wall Mount Bracket Kit (short bracket only) Part No. 101910	Sectional Overhead Door, Vertical Lift, High Lift	<ul style="list-style-type: none"> <li>• Direct Shaft Coupling</li> <li>• Sprocket to Sprocket</li> </ul>	4"-7"	
Wall Mount Bracket Kit (stacked short & long brackets) Part No. 101910	Sectional Overhead Door, Vertical Lift, High Lift	<ul style="list-style-type: none"> <li>• Direct Coupling</li> <li>• Sprocket to Sprocket</li> <li>• Heavy Duty mounting option</li> </ul>	6"-14"	

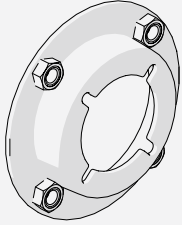
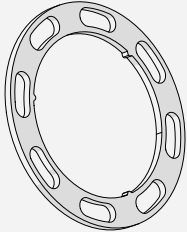
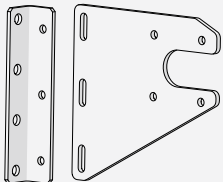
Bracket Name	Door Type	Install Type	Cable Drum Diameter	Image
Flanged Mounting Adaptor  Included in Part No. 101510 only	Rolling Steel (Steel Roller Shutter)	<ul style="list-style-type: none"> <li>Sprocket to Sprocket</li> <li>Retrofit to existing roller shutter mount (common in Australia &amp; New Zealand)</li> </ul>	N/A	
Mounting Bracket Spacer	Sectional Doors and North American type live axle Rolling Steel Doors.	<ul style="list-style-type: none"> <li>Sprocket to Sprocket, Direct Coupling</li> <li>Use with sectional and hood mount brackets</li> <li>Any install where DAVE'S gearbox is mounted against a flat surface.</li> <li>DO NOT USE WITH ANZ FLANGED MOUNTING ADAPTOR</li> </ul>	N/A	
Shutter Mounting Bracket Kit  Part No. 62622  Available in Australia only.	Rolling Steel (Steel Roller Shutter)	<ul style="list-style-type: none"> <li>Sprocket to Sprocket</li> </ul>	N/A	

## Drive Setup

### 10B (#50) SPROCKET AND CHAIN

Connects DAVE's drive shaft with door sprocket in sprocket to sprocket (jack shaft) installations.

Standard Drive Kit Replacement for DAVE Part No.101948

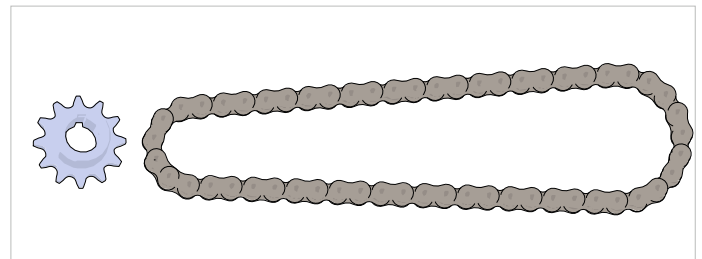

Fig:16

### SHAFT COUPLER (SOLD SEPARATELY)

Couples DAVE's drive shaft with sectional, high-lift and vertical lift door shafts in direct drive installations.

Available in Australia and New Zealand only

1" to 1" Coupler (CF100) - Part No. 102220

1" to 1.25" Coupler (CF105) - Part No. 102221



Fig:17



# Mounting Options

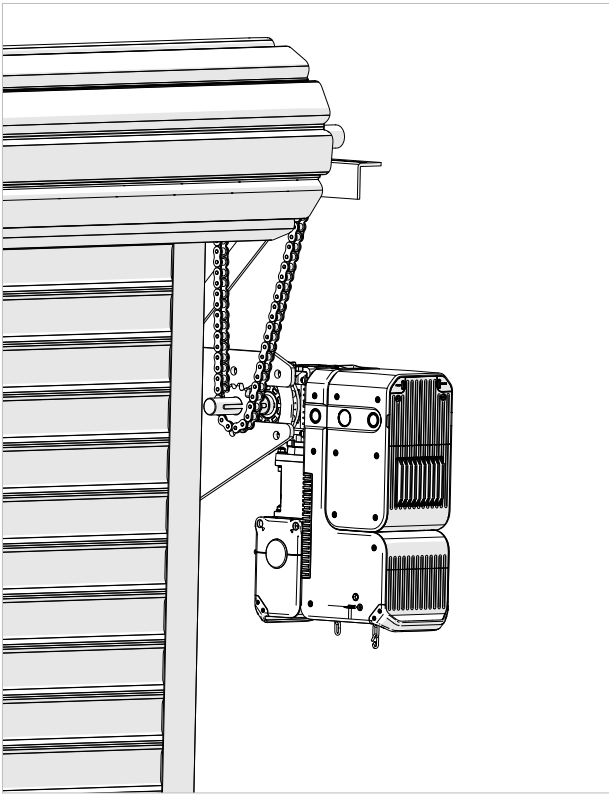

Fixed Axle Roller Shutter with Flanged Mounting Adaptor - common in AU / NZ

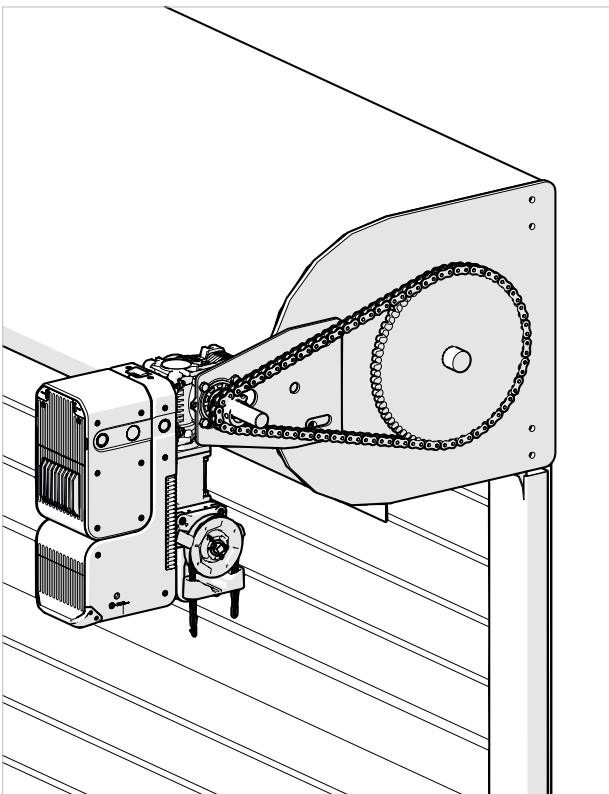
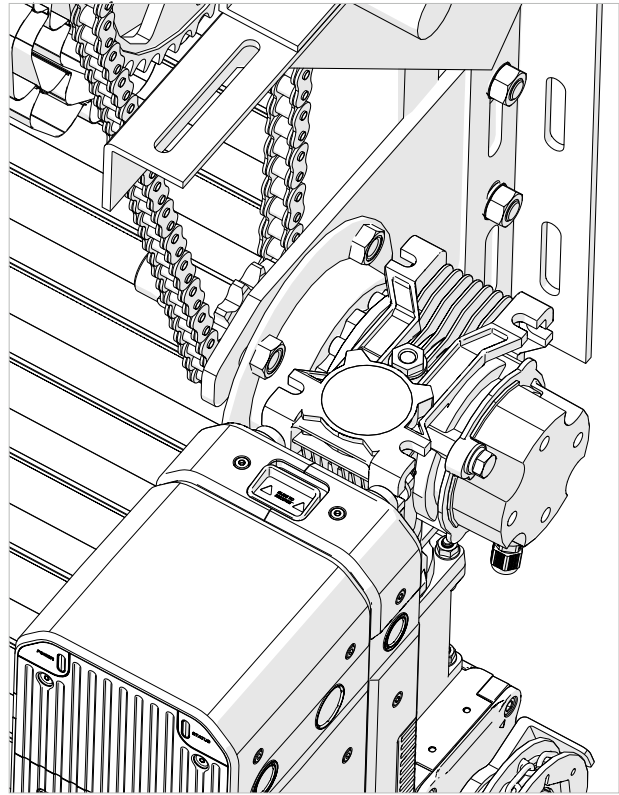

Hood Mount Variations Using Hood Mount Bracket Common in North America

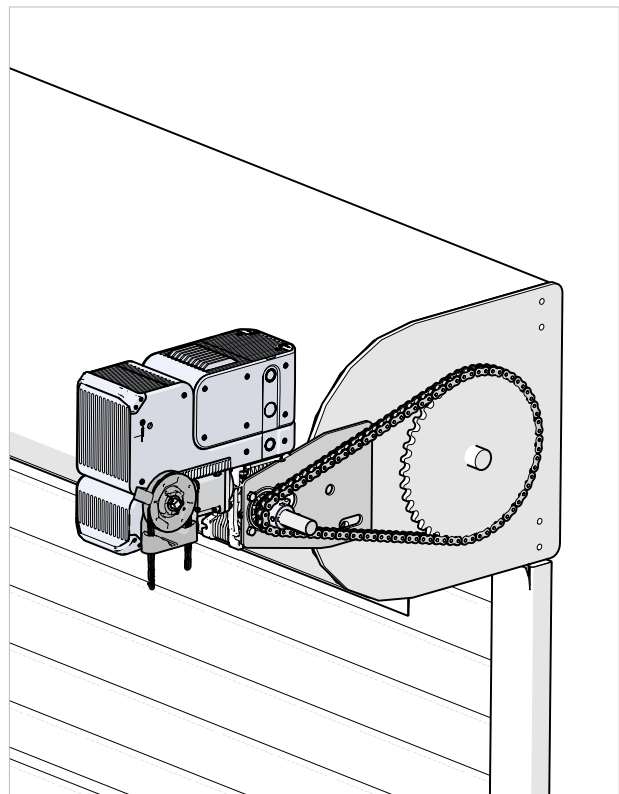

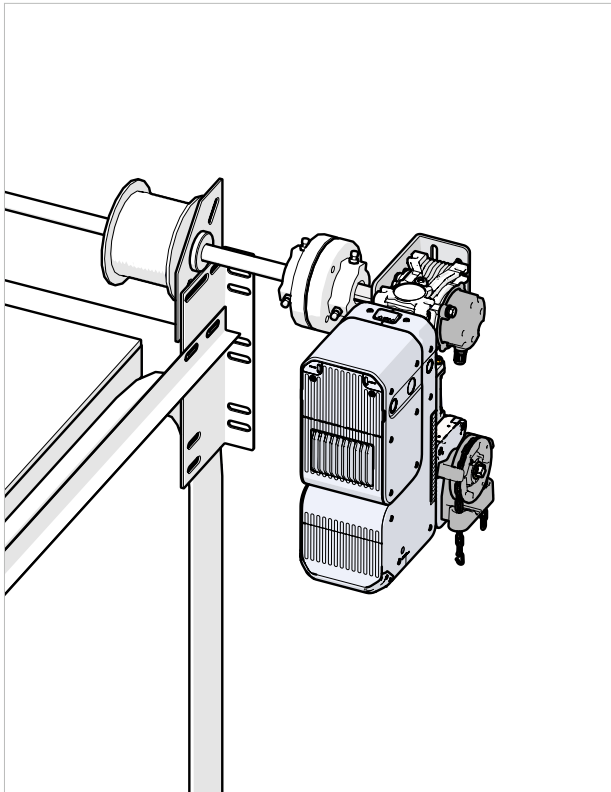

Standard Sectional Door Installation with Direct Coupling Adaptor and Short Sectional Bracket

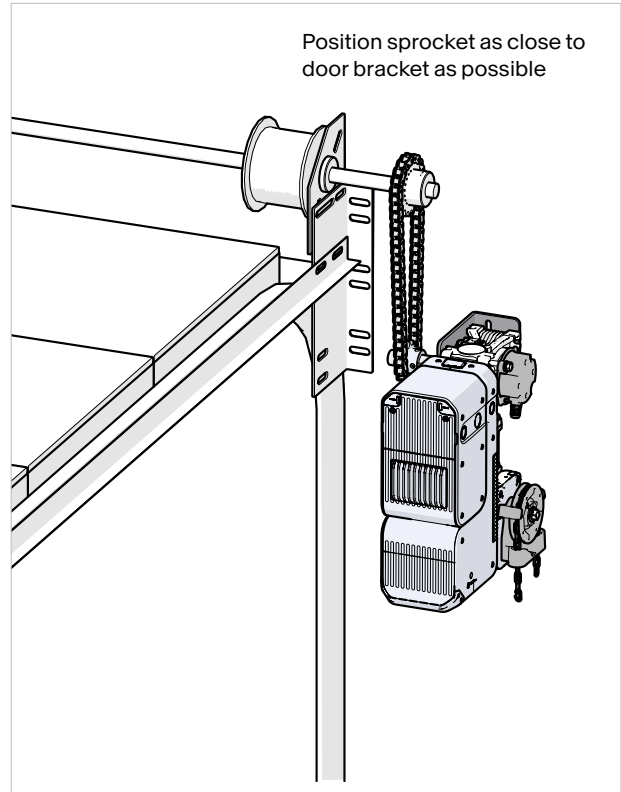

Standard Sectional Door Installation with Sprocket to Sprocket Drive and Short Sectional Bracket

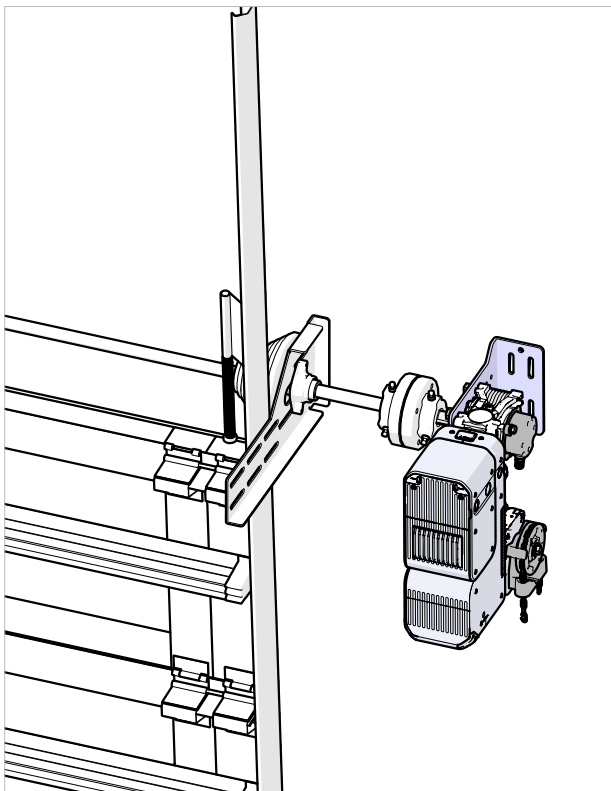

High Lift and Vertical Lift Sectional Door Installation with Direct Coupling Adaptor and Long Sectional Bracket

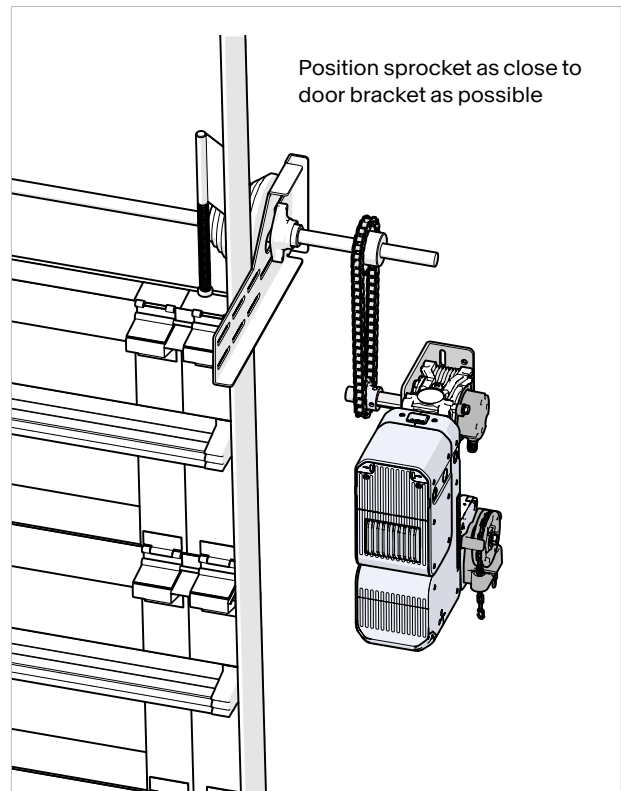

High Lift and Vertical Lift Sectional Door Installation with Sprocket to Sprocket Drive and Short Sectional Bracket

Short and long wall mount brackets can be stacked if required to provide additional support for heavy door installations.

# Wall Console

## Connectivity options

DAVE is a wireless-first solution. So, unless you've got a thing for wires, a wireless install configuration is the way to go..

See Pairing Wall Console on page 49 and Connecting Console to Operator By Cable on page 37 for full details.

## Power options

The wall console can be powered in one of three ways:

1. **Batteries:** 2x1.5V Type D Alkaline batteries.
2. **5V DC Power:** Via the 5V DC jack (power supply not included).
3. **Operator Powered:** Through the 4 core wall console cable (Part No. 102189. Sold separately).

## Mount Console to Wall with Appropriate Fasteners and Insert Batteries

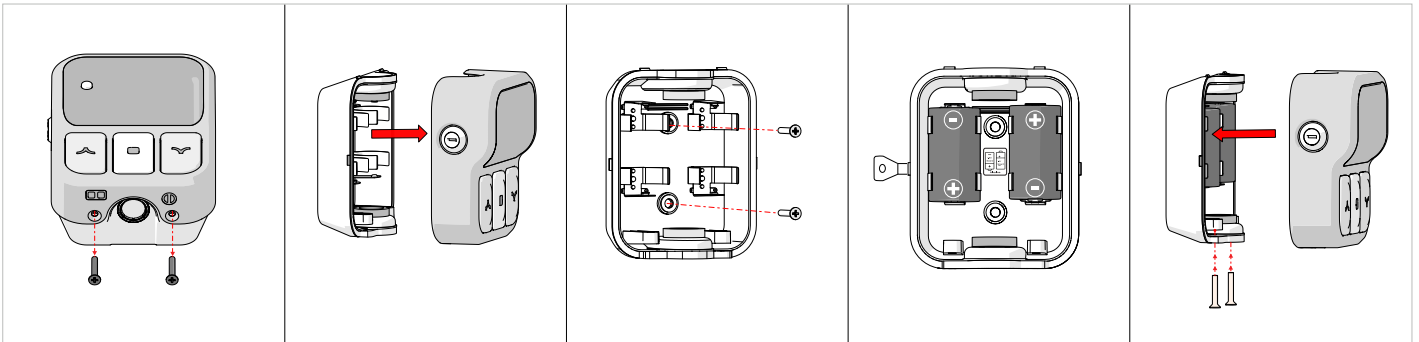

## Connecting 5v DC power supply

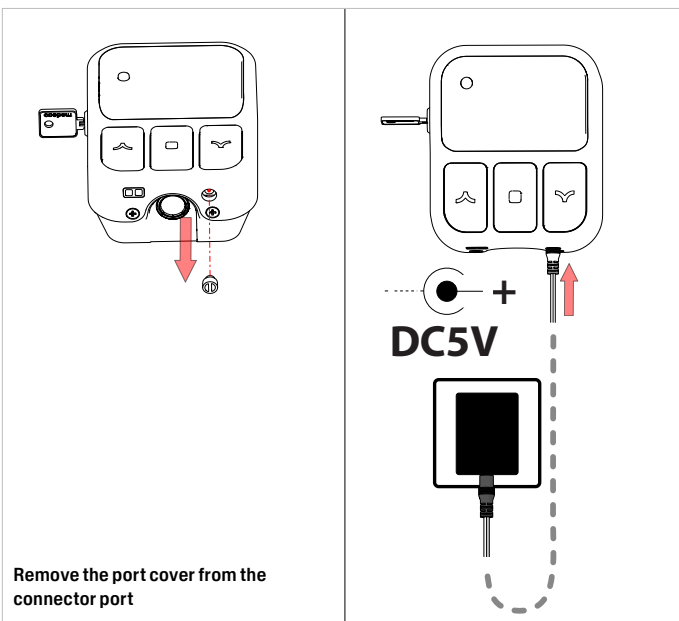

### ⚠ Warning

Batteries must be removed from console before connecting either 5v DC power supply or cable from powerhead. Do not use batteries if using alternate power sources.

### ⚠ Avertissement

Les piles doivent être retirées de la console avant de connecter soit l'alimentation 5 V CC, soit le câble provenant de l'opérateur. N'utilisez pas de piles si vous utilisez d'autres sources d'alimentation.

# Console Operating Controls

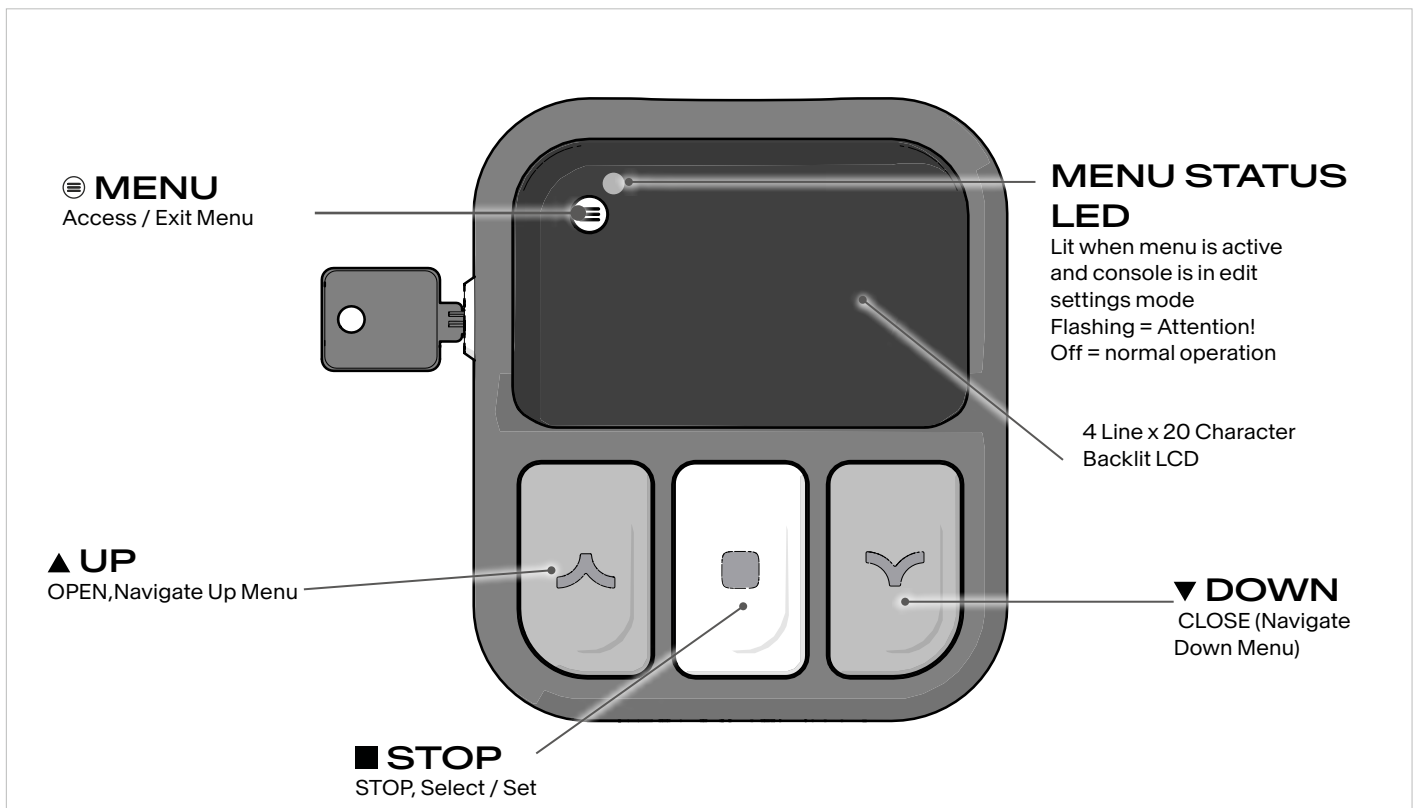

Wireless Wall Console

**🔒 LOCKED**  
Disable menu access to change settings



**🔓 UNLOCKED**  
Enable menu access to change settings

**PROGRAMMER PORT**  
For PG3 programmer

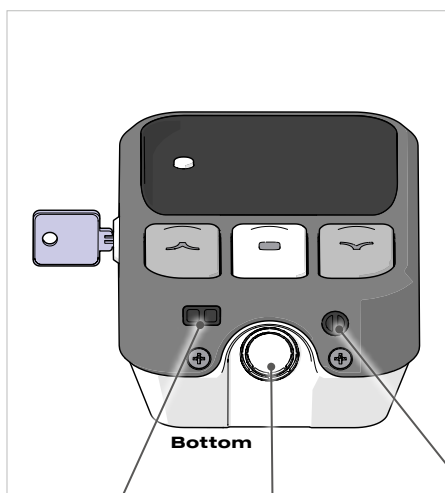

**PUNCHOUT**  
16mm & 20mm.  
For optional cabled connection to operator and accessory wire pass through.

**PUNCHOUT**  
For optional cabled connection to operator

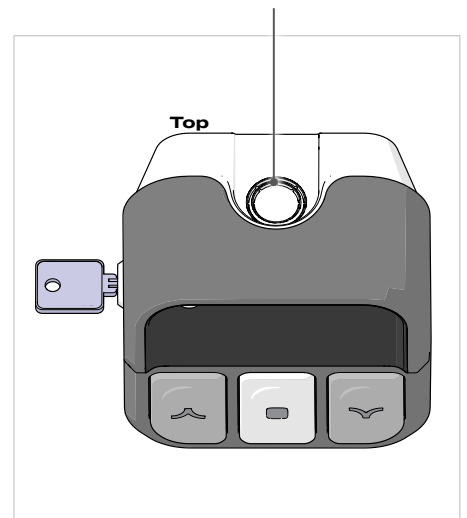

**5V DC JACK**  
Power jack for optional DC power supply

# Connecting Console to Operator By Cable

## Removing Internal Cable Conduit Cover

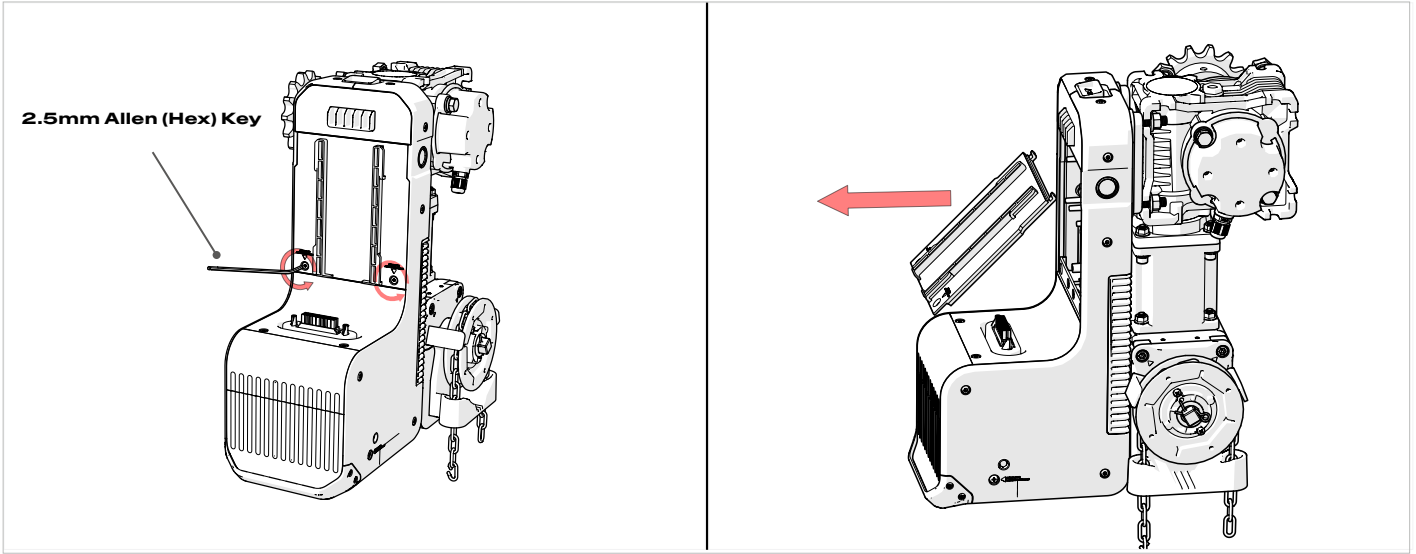

## Removing Main Control Board Access Cover

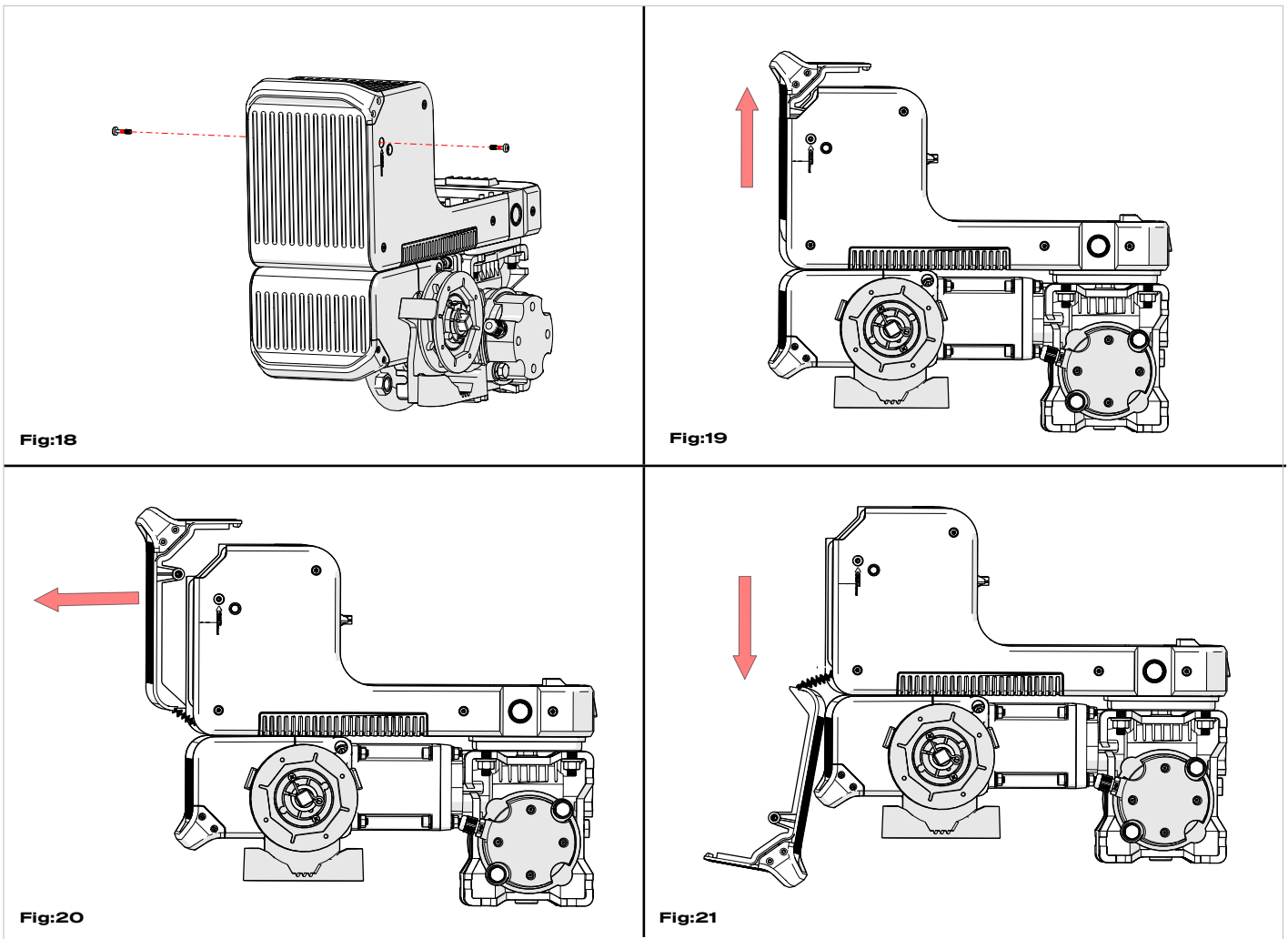

## Wiring Path for Console and Accessories

- Choose the best approach and side of entry into the operator for wiring. To minimise risk of entangling cables with the DAVE's drive mechanism, this will be the opposite side to the drive shaft and door in most circumstances. Wiring punch-outs are located on both sides, as shown in Fig:22. Remove punch-out on your chosen side.
- Unfasten cover using 2.5mm Allen (hex) key and remove.
- Unfasten captive screws to open rear door.
- Feed cable through punch-out, wiring channel and into main control board access compartment - see Fig:23.

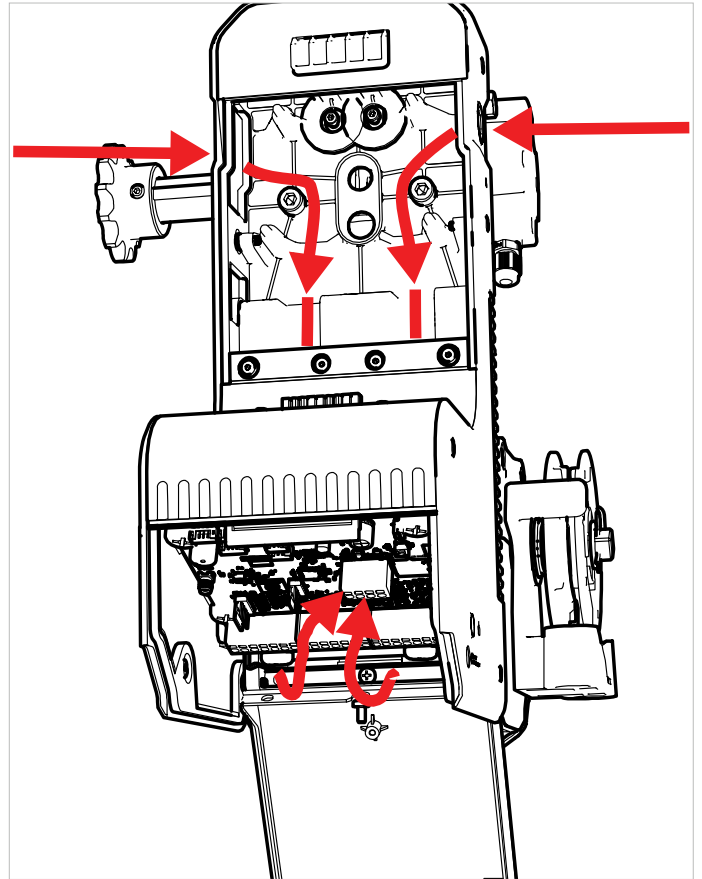

Fig:22

## Connecting Console and Control Board Terminals

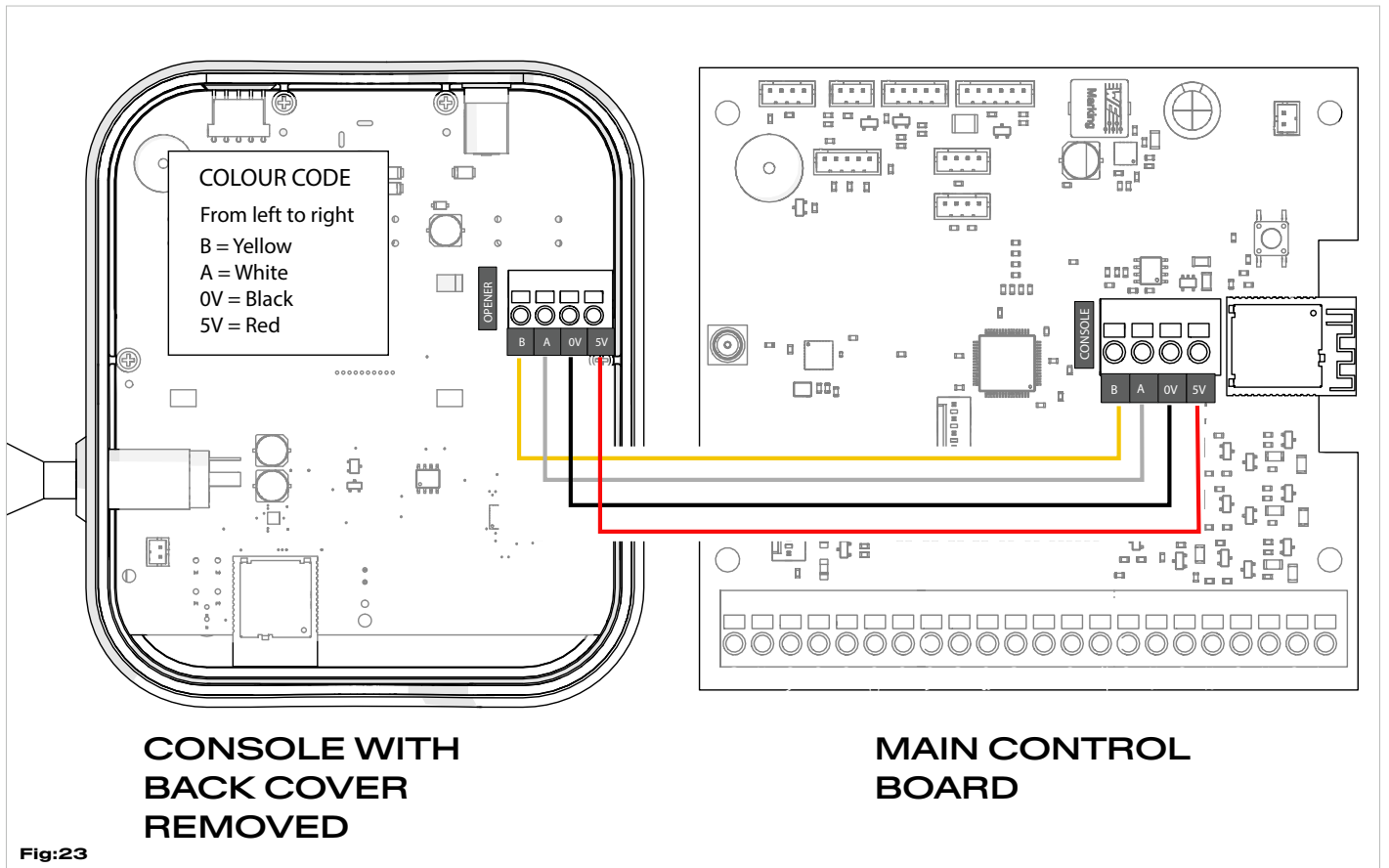

Fig:23

# Warning Placards

Included in part No. 101511 (North America) only

Entrapment warning placards must be installed on all installations in the United States and Canada.

A French language version of the placard is supplied for use in Canada, where bilingual safety warnings are mandatory.

Attach the entrapment warning placard on the wall near the door control with tacks or staples at a minimum height of 5 feet (1.53 metres) above floors, landings, steps or other adjacent walking surface so shall children are not able to reach it.

**Do not remove or paint over these Placards**

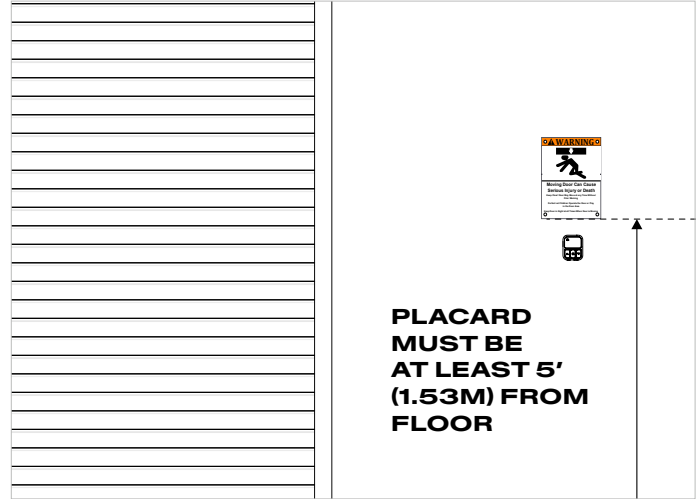

## **5. CONNECTING TO POWER**





## EMERGENCY STOP REQUIREMENT

- An emergency stop button **must be permanently wired** into the mains (electrical) power supply for the opener or operator.
- When pressed, the emergency stop **must immediately override all other functions** and bring the system to a safe stop without creating any new hazards.
- The emergency stop **must not cause the system to restart automatically** under any circumstances.



## EXIGENCE D'ARRÊT D'URGENCE

- Un bouton d'arrêt d'urgence **doit être câblé de façon permanente** à l'alimentation principale de l'opérateur.
- Lorsqu'il est actionné, l'arrêt d'urgence **doit immédiatement neutraliser toutes les autres fonctions** et amener le système à un arrêt sécurisé sans créer de nouveaux dangers.
- L'arrêt d'urgence **ne doit en aucun cas provoquer un redémarrage automatique du système.**



## WARNING

**If using a wired connection between console and operator, do not turn the power on to the operator before connecting the console.**



## AVERTISSEMENT

**Si vous utilisez une connexion filaire entre la console et l'opérateur, ne mettez pas l'opérateur sous tension avant d'avoir connecté la console.**

# OmniVolt® Power Cartridge Details

Power must be supplied to DAVE by an OmniVolt® power cartridge (sold separately). Please follow your OmniVolt® instruction guide for configuration information and specifications.

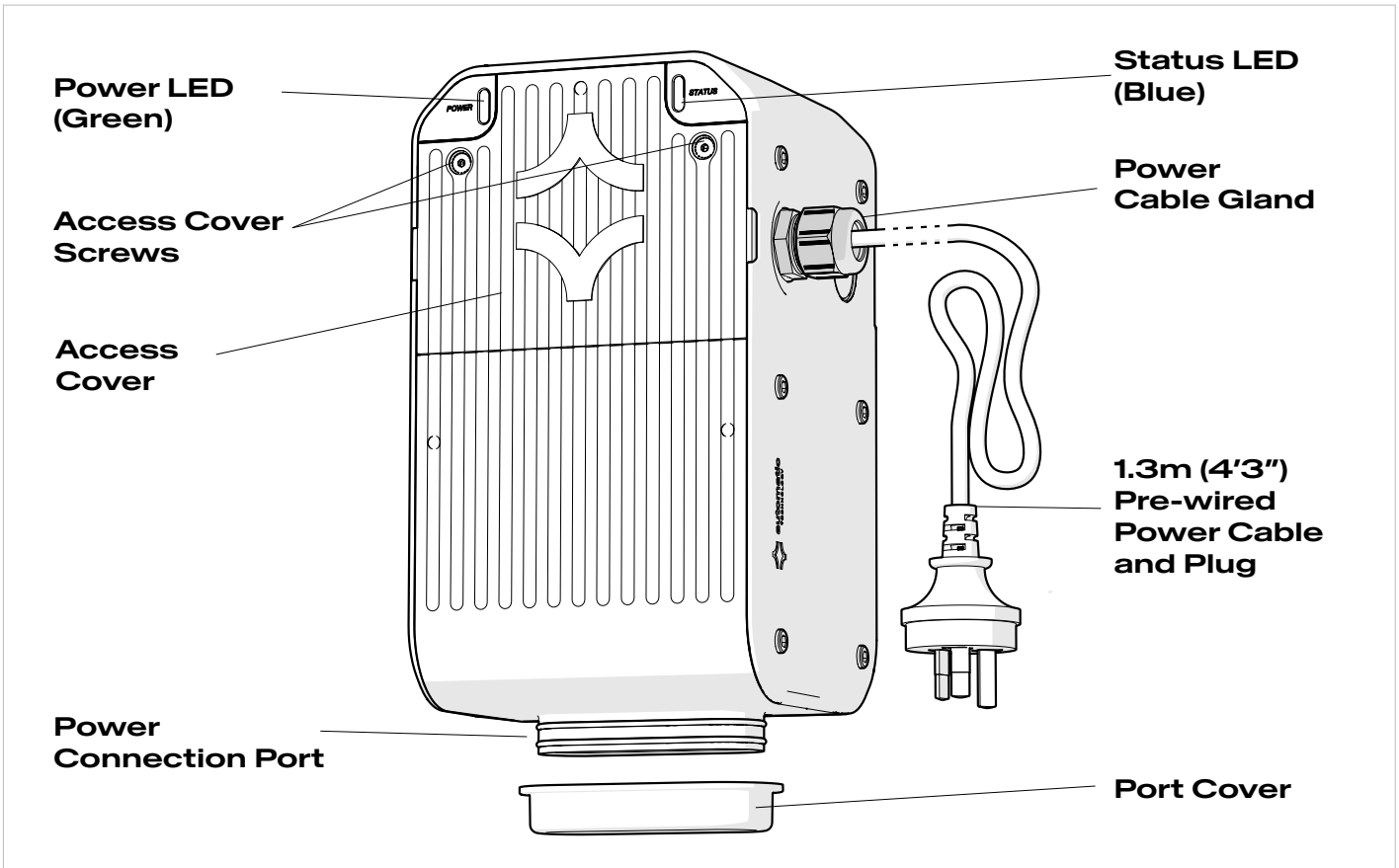

Fig:24

## OmniVolt® Cartridge Options

Low Voltage	120-240vac 50/60Hz	Part No. 101641
Low Voltage	230-240vac 50/60Hz	Part No. 101640
High Voltage	400-480vac 50/60Hz	Part No. 101642

# Connecting OmniVolt® Power Cartridge

**IMPORTANT:** If swapping a currently installed OmniVolt® power cartridge, electrical power must be switched off at the wall (or power switchboard if wired in) and both LEDs fully off before removing the power cartridge. After switching off electrical power, it can take several minutes for the blue status LED to go out. Failure to follow this instruction may permanently damage the operator's circuitry.

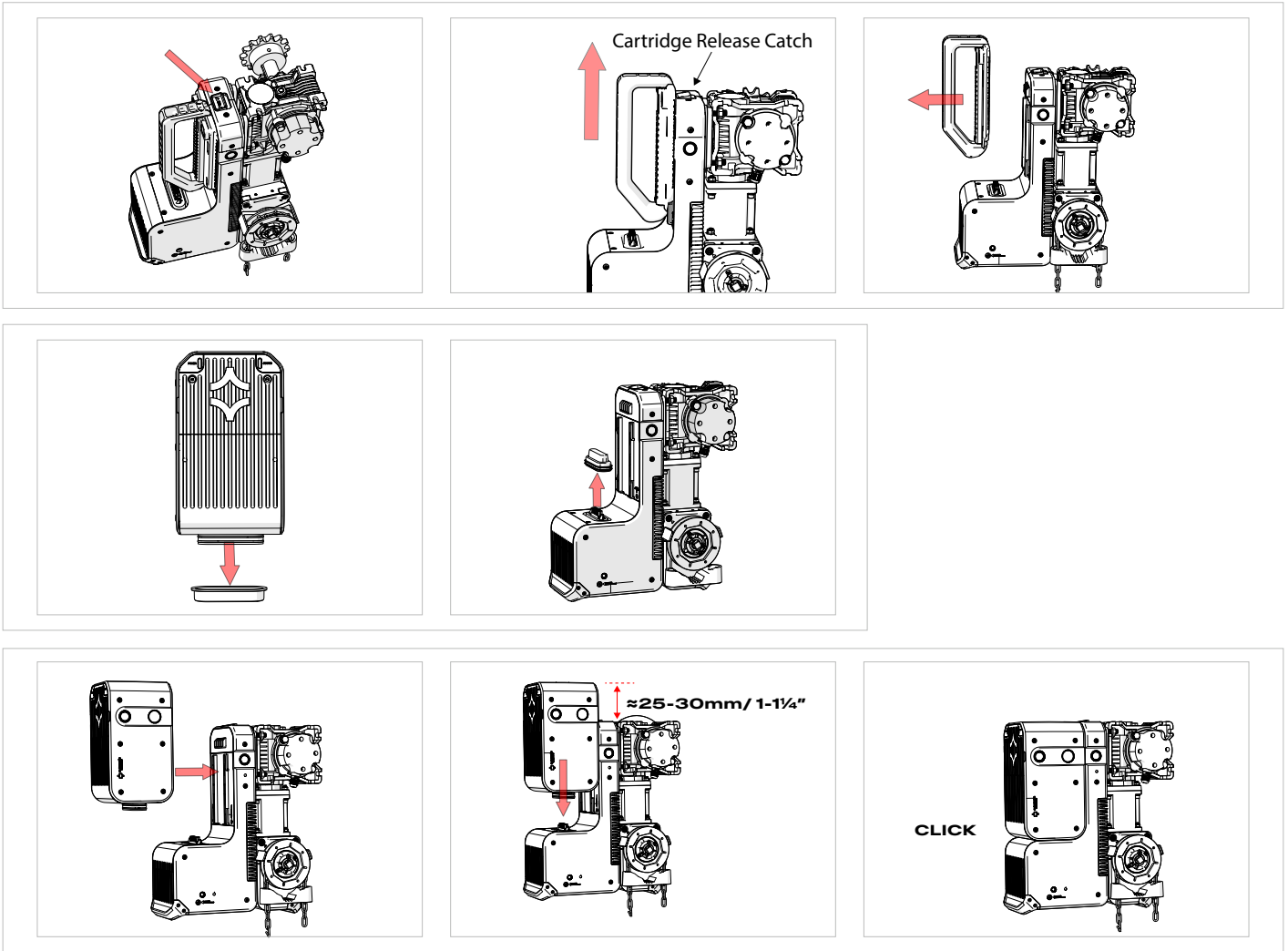

## Configure cartridge power cable connection

The OmniVolt® low-voltage power cartridge is pre-wired with a 1.3m (5') power cable and AC plug, with the cable on its right hand side.

- **Low Voltage Cartridge:** If no power outlet is within reach, the Low Voltage Cartridge may be wired directly into mains power (also known as line power in North America)
- **High Voltage Cartridge:** This must be wired directly into mains power (line power). It supports both three phase and single-phase connections, as long as a neutral wire is present.

Follow the Omnivolt instruction guide for guidance.

Depending on local electrical regulations, any modification to the power cartridge—such as relocating the cable or wiring directly into mains power—must be carried out by a licensed electrician or electrical contractor.

## 6. WIRING DETAIL

# Main Control Board Overview

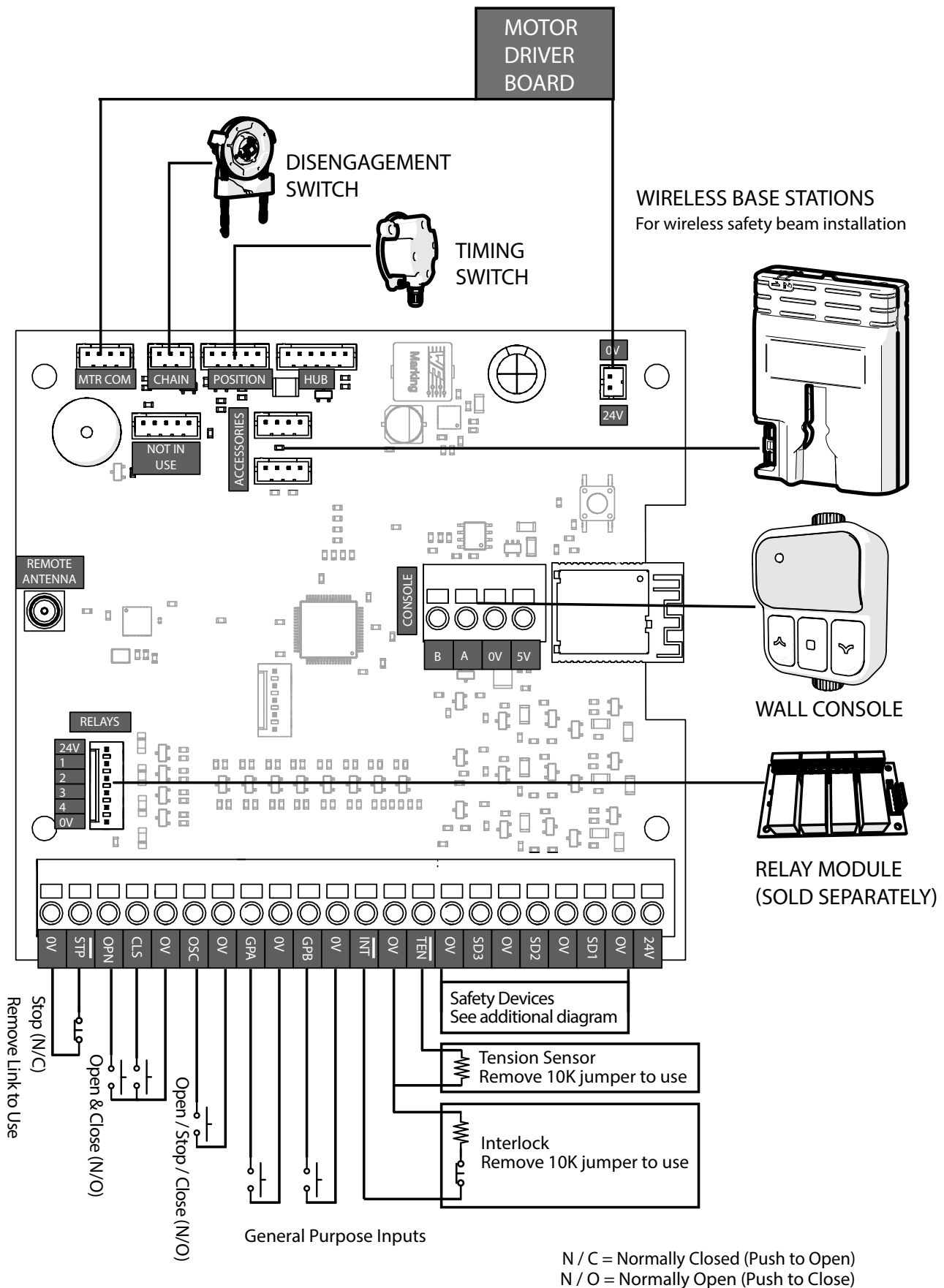

# Main Control Board Terminals

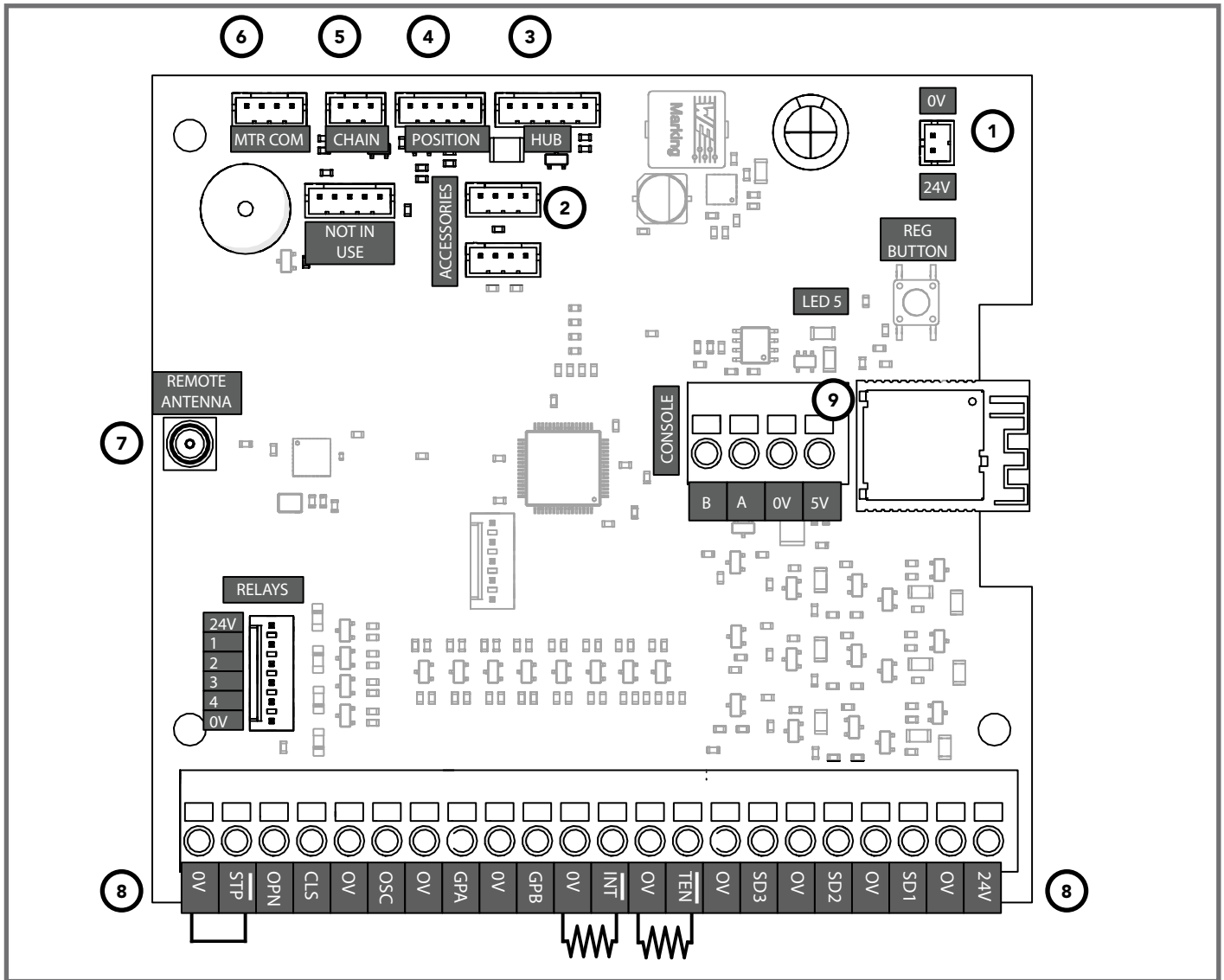

Fig:25

## MAIN CONTROL BOARD KEY

KEY	CONNECTORS	DESCRIPTION
1	24V 0V	24V power input to control board
2	ACCESSORIES (2)	BLE base station safety beam connector
3	HUB	WiFi device interface
4	POSITION	Door position encoder
5	CHAIN	10K monitored hand operated chain for manual opening and closing
6	MTR COM	Motor controller
7	REMOTE ANTENNA	Remote control receiver antenna
8	EXTERNAL CONNECTOR BLOCK	See table 6.2: top external connector block key
9	CONSOLE	Wall console power and communications

## TERMINAL BLOCK KEY

TERMINAL	TYPE	PURPOSE
STP 0V	NORMALLY CLOSED	Stop control input
OPN 0V	NORMALLY OPEN	Open control input
CLS 0V	NORMALLY OPEN	Close control input
OSC 0V	NORMALLY OPEN	Single button OPEN / STOP / CLOSE control input
GPA 0V	NORMALLY OPEN	General purpose control input A
GPB 0V	NORMALLY OPEN	General purpose control input B
INT 0V		Interlock input - monitored 10K input
TEN 0V	10K	Cable tension input - monitored 10K input
SD1, SD2, SD3 0V	SB/PUL/10K	Safety device inputs - SD type selected in settings menu. Options are: SB - AT 2 wire 5V safety beam PUL - monitored 325Hz pulse input 10K - monitored 10K input
24V 0V	24 VOLT DC OUTPUT	24VDC output for powering safety devices and accessories

## **7. SETUP & PROGRAMMING OPTIONS**



# Pairing Wall Console

THE WALL CONSOLE AND DRIVE UNIT SHIP PRE-PAIRED FROM THE FACTORY. THEY CAN BE UN-PAIRED AND RE-PAIRED IF NECESSARY, OR EITHER DEVICE MAY BE PAIRED TO AN ALTERNATIVE.

The drive unit and console rely on two separate channels for wireless communication with each other:

1. Bluetooth: for messaging, status updates, settings changes etc.
2. RF Link: for operator drive control only – OPEN, STOP, CLOSE commands.

Pairing a wall console with the drive unit requires separate pairing steps for Bluetooth and RF-Link. These steps follow sequentially in the setup procedure (Fig:26 - Fig:37) and must both be completed for the operator to function normally.

NOTE: A wall console can only be paired with one drive unit at a time and a drive unit can only be paired with one wall console at a time. Therefore, if replacing a console, the old one must be unpaired.

## BLUETOOTH PAIRING

1. Open the access door on the drive unit by unscrewing two Phillips head screws.
2. Fig:26 shows the start screen of the pairing wizard. Press  $\equiv$  to begin and follow the instructions on screen up to Fig:29.
3. If the green LED5 to the left of the red REG button on the main control board is lit (see Fig:32), the drive unit is ready for pairing. If it is not lit it is already paired to a wall console and must be unpaired.

To complete the Bluetooth pairing process, press and hold the red REG button for 3 seconds until the green LED5 starts flashing. After flashing for a few seconds the green LED5 will go out and Fig:30 will display. Press  $\blacksquare$  to continue and follow the instructions to complete the RF Link Learning process that follows.

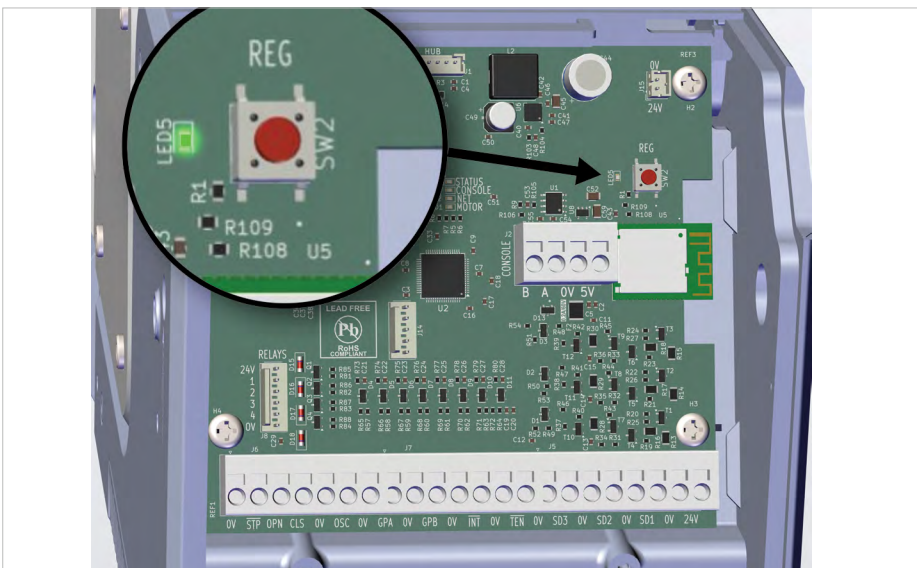

Fig:32

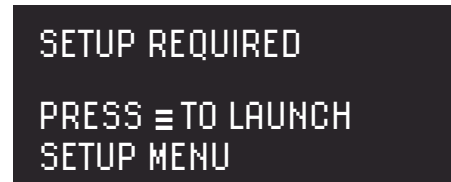

Fig:26

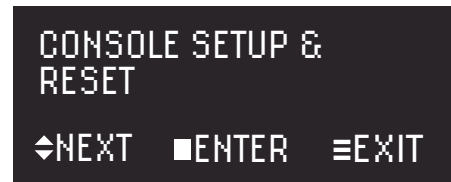

Fig:27

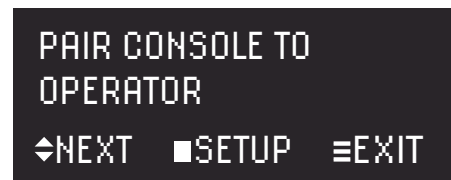

Fig:28



Fig:29

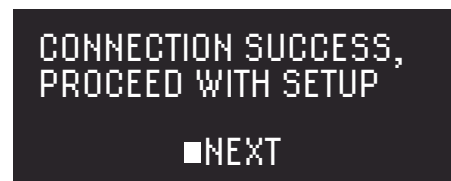

Fig:30

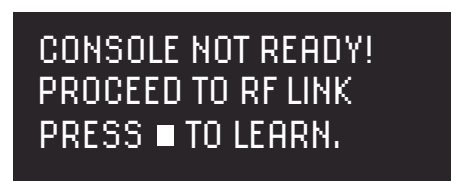
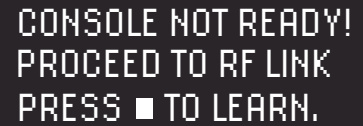

Fig:31

## RF LINK LEARNING

The RF Link connection steps follow on sequentially after completing the Bluetooth pairing steps shown in **Fig:26-Fig:31**.

Once Bluetooth pairing has completed, the screen shown in **Fig:33** will appear. Press **■**. From here the console will step through the screens shown in **Fig:34 - Fig:37** without any need for interaction.



```
CONSOLE NOT READY!  
PROCEED TO RF LINK  
PRESS ■ TO LEARN.
```

Fig:33

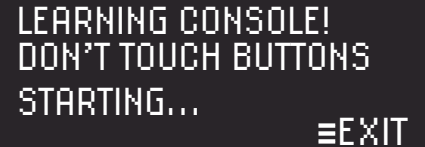

```
LEARNING CONSOLE!  
DON'T TOUCH BUTTONS  
STARTING...  
≡EXIT
```

Fig:34

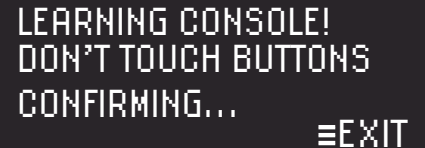

```
LEARNING CONSOLE!  
DON'T TOUCH BUTTONS  
CONFIRMING...  
≡EXIT
```

Fig:35



```
CONSOLE REMOTE  
BUTTONS STORED
```

Fig:36

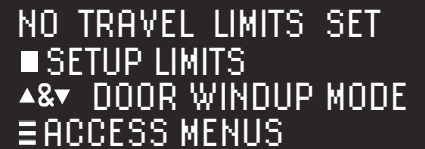

```
NO TRAVEL LIMITS SET  
■ SETUP LIMITS  
▲&▼ DOOR WINDUP MODE  
≡ ACCESS MENUS
```

Fig:37

## DOOR WINDUP MODE

Door windup mode is a convenient utility for winding rolling steel door curtains onto the drum at installation time.

When selected, the console enters dead-man (constant-contact) mode allowing the drum to be turned slowly in either direction as required.

To activate door windup mode, press **▲** and **▼** simultaneously when prompted from the screen (**Fig:37**).

After attaching the door curtain to the drum follow the manufacturer's instructions to complete installation.

# Wall Console Power Modes

DAVE's wall console supports three power modes to suit different installation types and power sources. Each mode affects how and when the console wakes up, helping balance responsiveness with power efficiency.

## NOTIFY [HIGH POWER]

- Wakes up on any change, including actions from remotes or other control sources.
- Highest power usage mode.
- Recommended only when using:
  - 5VDC mains power supply, or
  - Direct wired connection to DAVE.

## INTERACT [BALANCED]

- Wakes up only when the console is used.
- Offers a balanced power consumption.
- Suitable for most setups, including battery powered (with moderate usage).

## SLEEP [POWER SAVER]

- Wakes up only when the **MENU** (≡) button is pressed.
- Does not wake for Up, Down, or Stop actions.
- Best mode for maximising battery life.

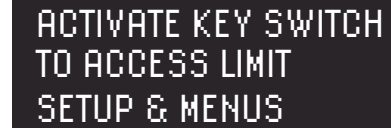

ACTIVATE KEY SWITCH  
TO ACCESS LIMIT  
SETUP & MENUS

Fig:38



1: REMOTE CONTROL  
LEARN MENU

◀NEXT ■START ≡EXIT

Fig:39



4: CONSOLE MENU

◀NEXT ■ENTER ≡EXIT

Fig:40



### IMPORTANT TECH NOTE

**Continuous flashing from the wall console LED indicates that an important system alert has been triggered. If the console power mode is set to INTERACT or SLEEP, please press MENU (≡) to review the alert, as the LCD screen does not wake up automatically.**

## CHANGING WAKE MODE SETTINGS

### 1. Activate the Console

If the console screen is off, press **MENU** (≡). If it remains off, check the power source.

### 2. Unlock the Key Switch

The key switch must be unlocked to proceed. If locked, the console will prompt you (Fig:38).

### 3. Access Console Settings Menu

Press **MENU**(≡) repeatedly until Fig:39 appears. From here toggle through the menu using ▲ or ▼ to reach Fig:40. Use ■ to access the Console Settings.

### 4. Edit Console Settings

At Fig:41 press ■. The next screen (Fig:42) shows the current Wake Mode setting, which in this example, is NOTIFY. Press ■ to change the setting. Fig:43 shows the edit screen and displays the editable setting Use ▲ or ▼ to toggle through the 3 options and ■ to save a new option.

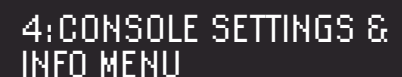

4: CONSOLE SETTINGS &  
INFO MENU

◀NEXT ■ENTER ≡EXIT

Fig:41



WAKE MODE  
NOTIFY

◀NEXT ■EDIT ≡EXIT

Fig:42

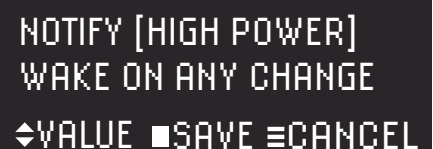

NOTIFY [HIGH POWER]  
WAKE ON ANY CHANGE  
◀VALUE ■SAVE ≡CANCEL

Fig:43

# Using Remote Controls (Transmitters)

DAVE can store up to 63 remote controls in its memory.

**Important: Only the Automatic Technology 4 Button Remote (Part No. 102335) is compatible with this system (see Fig:44).**

Each button on a remote can be programmed to perform a different function.

The default setup sequence, as described in **LEARNING A REMOTE CONTROL (TRANSMITTER) on page 54**, assigns the **Normal Operation** function to a single button of the user's choosing during the setup sequence.

You can also assign a button to perform a dedicated function only, such as just opening, just closing, or turning on a light. See **Available Functions** below for a complete list of functions that can be assigned to any button

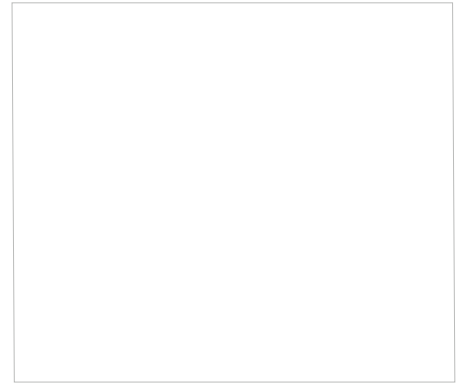

Fig:44

## AVAILABLE FUNCTIONS

### Normal Operation

- **OPEN / STOP / CLOSE:** One button cycles through the commands in this order Open → Stop → Close

### Dedicated Functions

- **OPEN:** Opens the door only.
- **STOP:** Stops the door movement only.
- **CLOSE:** Closes the door only.
- **PARTIAL OPEN:** Opens the door to a secondary limit position.
- **REMOTE LOCKOUT:** Disables all stored remote controls.
- **AUXILIARY OUTPUT:** (requires relay module) Activates an external device. Time settings control how long the output stays on.

## TRANSMITTERS COMPLIANCE STATEMENT

Transmitters comply with all United States and Canadian legal requirements as of the date of manufacture. To comply with **FCC Part 15** and/or **RSS 210 Innovation, Science and Economic Development Canada** rules, adjustment or modifications of this receiver and/or transmitter are prohibited, except for changing the code setting or replacing the battery. There are no other user serviceable parts. Tested to comply with FCC standard for home or office use. This device contains licence-exempt transmitter(s)/receiver(s) that comply with Innovation, Science and Economic Development Canada's licence-exempt RSS(s). Operation is subject to the following two conditions:

1. This device may not cause interference.
2. This device must accept any interference, including interference that may cause undesired operation of the device.

**Note:** This equipment has been tested and found to comply with the limits for a Class B digital device,

pursuant to Part 15 of the FCC rules. These limits are designed to provide reasonable protection against harmful interference in a residential installation. This equipment generates, uses and can radiate radio frequency energy and, if not installed and used in accordance with the instructions, may cause harmful interference to radio communications. However, there is no guarantee that interference will not occur in a particular installation. If this equipment does cause harmful interference to radio or television reception, which can be determined by turning the equipment off and on, the user is encouraged to try to correct the interference by one or more of the following measures:

- Reorient or relocate the receiving antenna;
- increase the separation between the equipment and receiver;
- Connect the equipment into an outlet on a circuit different from that to which the receiver is connected; consult your local dealer or an experienced radio/TV technician for help.

## DÉCLARATION DE CONFORMITÉ DE L'ÉMETTEUR

Les émetteurs sont conformes à toutes les exigences légales des États-Unis et du Canada à la date de fabrication. Pour se conformer aux règles de **la FCC partie 15** et/ou **RSS 210 d'Innovation, Sciences et Développement économique Canada**, tout réglage ou modification de ce récepteur et/ou émetteur est interdit, sauf pour le changement du code ou le remplacement de la pile. Il n'y a aucune autre pièce réparable par l'utilisateur. Testé conforme à la norme FCC pour une utilisation à domicile ou au bureau. Cet appareil contient un ou des émetteurs/récepteurs exempts de licence qui sont conformes aux CNR exempts de licence d'Innovation, Sciences et Développement économique Canada. L'utilisation est soumise aux deux conditions suivantes : cet appareil ne doit pas causer d'interférences. Cet appareil doit accepter toute interférence, y compris celle pouvant provoquer un fonctionnement indésirable.

**Remarque :** Cet équipement a été testé et déclaré conforme aux limites applicables à un appareil numérique de classe B, conformément à la partie

15 des règles de la FCC. Ces limites visent à assurer une protection raisonnable contre les interférences nuisibles dans une installation résidentielle. Cet équipement génère, utilise et peut émettre de l'énergie radiofréquence et, s'il n'est pas installé et utilisé conformément aux instructions, peut causer des interférences nuisibles aux communications radio. Cependant, il n'est pas garanti qu'aucune interférence ne se produira dans une installation particulière. Si cet équipement cause des interférences nuisibles à la réception radio ou télévision, ce qui peut être déterminé en éteignant puis en rallumant l'équipement, l'utilisateur est encouragé à essayer de corriger l'interférence par une ou plusieurs des mesures suivantes :

- Réorienter ou déplacer l'antenne de réception;
- Augmenter la distance entre l'équipement et le récepteur;
- Brancher l'équipement sur une prise d'un circuit différent de celui auquel le récepteur est connecté ; consulter votre revendeur local ou un technicien radio/TV expérimenté pour obtenir de l'aide.

# LEARNING A REMOTE CONTROL (TRANSMITTER)

The following procedure explains how to program a compatible remote for a single button. Steps 5 -8 need to be repeated for each button that needs to be programmed. It is not possible to program multiple buttons on a remote in a single pass.

## 1. Before You Begin

Ensure DAVE is powered on and connected to a wall console with a working power source. The console must be either wirelessly paired or physically wired to DAVE's control board.

## 2. Activate the Console

If the console screen is off, press MENU (≡). If it remains off, check the power source.

## 3. Unlock the Key Switch

Unlock the key switch to proceed. If locked, the console will prompt you (Fig:45).

## 4. Access Remote Control Learn Menu

If you do not see the screen shown in Fig:46 press Press ≡ repeatedly until you see it

## 5. Select Function To Assign to Remote Button

To assign **Normal Operation** (OPEN/STOP/CLOSE) to the button you want to program, press ■ at Fig:47.

Alternatively, to assign a dedicated function to the button (e.g. CLOSE, PARTIAL OPEN, or REMOTE LOCKOUT), toggle through the list of available functions using ▲ or ▼. Use ■ to confirm your selection.

## 6. Enter Secure Learning Mode

The screen at Fig:48 covers 2 separate user actions. Here we cover Fig:48, Action-1: Hold Button 1 and Button 2 on the remote together to enter secure learning mode (Fig:51 below shows button numbers). Continue holding Buttons 1 & 2 until the red LED on the remote starts flashing, then release immediately. When the LED stops flashing DAVE is now ready for you to select the button you want to program with your chosen function.

## 7. Choose a Remote Button

Continuing to Fig:48, Action 2: Press whichever remote button you wish to program. When this button registers with DAVE, the screen as shown in Fig:49 will show. Press the same button again to confirm your choice.

## 8. Confirmation

Once you have confirmed your choice of button, the confirmation screen shown in Fig:50 displays.

## 9. Return To Main Screen

Press ≡ to return to the main screen and test the remote. Note the remote will not work until this last step has been completed.

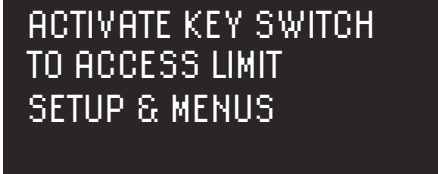

ACTIVATE KEY SWITCH  
TO ACCESS LIMIT  
SETUP & MENUS

Fig:45, Step 3



1: REMOTE CONTROL  
LEARN MENU

◀NEXT ■START ≡EXIT

Fig:46, Step 4



LEARN REMOTE FOR  
OPEN/STOP/CLOSE

◀NEXT ■START ≡EXIT

Fig:47, Step 5

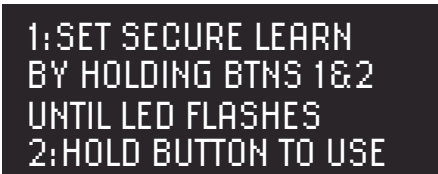

1: SET SECURE LEARN  
BY HOLDING BTNS 1&2  
UNTIL LED FLASHES  
2: HOLD BUTTON TO USE

Fig:48, Steps 6&7



PRESS AGAIN  
TO CONFIRM

Fig:49, Step 7



REMOTE CONTROL  
BUTTON STORED

Fig:50, Step 8

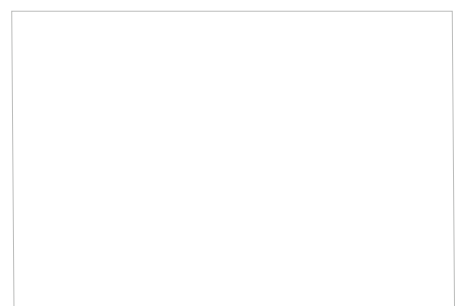

Fig:51

# UNLEARNING REMOTE CONTROLS

The following procedure removes all remote controls from DAVE's memory.

## 1. Before You Begin

Ensure DAVE is powered on and connected to a wall console with a working power source. The console must be either wirelessly paired or physically wired to DAVE's control board.

## 2. Activate the Console

If the console screen is off, press  $\equiv$ . If it remains off, check the power source.

## 3. Unlock the Key Switch

The key switch must be unlocked to proceed. If locked, the console will prompt you (Fig:52).

## 4. Access Memory Reset and Configure Menu

Fig:53 shows the menu home screen for a normally configured operator and wall console pair. If something else is showing press  $\equiv$  repeatedly until it appears.

From Fig:53 toggle through the menu using  $\blacktriangle$  or  $\blacktriangledown$  to reach Fig:54. Use  $\blacksquare$  to access the Memory Reset options

## 5. Unlearn All Remotes From Memory

Toggle through the menu using  $\blacktriangle$  or  $\blacktriangledown$  to reach Fig:55.

Press  $\blacksquare$  to unlearn (clear) all remotes in DAVE's memory. At Fig:56 press  $\blacksquare$  once again to confirm. The console will display Fig:57 during the unlearn process.

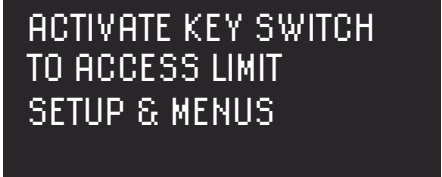

ACTIVATE KEY SWITCH  
TO ACCESS LIMIT  
SETUP & MENUS

Fig:52



1: REMOTE CONTROL  
LEARN MENU

$\blacktriangle$ NEXT  $\blacksquare$ START  $\equiv$ EXIT

Fig:53



5: MEMORY RESET &  
CONFIGURE MENU

$\blacktriangle$ NEXT  $\blacksquare$ START  $\equiv$ EXIT

Fig:54

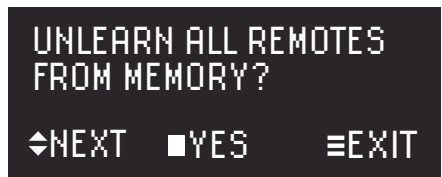

UNLEARN ALL REMOTES  
FROM MEMORY?

$\blacktriangle$ NEXT  $\blacksquare$ YES  $\equiv$ EXIT

Fig:55

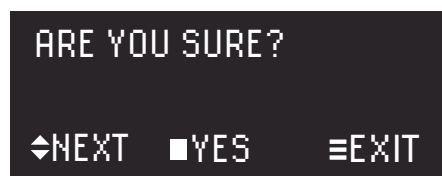

ARE YOU SURE?

$\blacktriangle$ NEXT  $\blacksquare$ YES  $\equiv$ EXIT

Fig:56

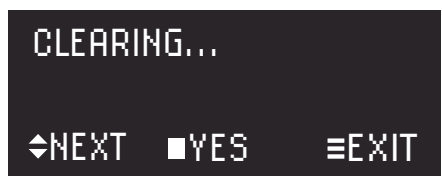

CLEARING...

$\blacktriangle$ NEXT  $\blacksquare$ YES  $\equiv$ EXIT

Fig:57

# Setting Limits

## 1. Before You Begin

Ensure DAVE is powered on and connected to a wall console with a working power source. The console must be either wirelessly paired or physically wired to DAVE.

Preferably, start with the door halfway open.

**Note:** Consoles ship pre-paired with DAVE.

## 2. Activate the Console

If the console screen is off, press . If it remains off, check the power source.

## 3. Unlock the Key Switch

Unlock the key switch to proceed. If locked, the console will prompt you (Fig:58).

## 4. Access Limit Setup

If limits are unset, the console defaults to the limit setup screen (Fig:59). If not visible, press repeatedly until it appears.

## 5. Select Door Type

At the door type screen (Fig:14), the default is **STANDARD SECTIONAL**. Press to accept or to edit.

To change the door type, select within 3 minutes. Otherwise, the setup wizard retains the default and proceeds (Fig:61).

To return and modify, abort setup by pressing , then .

## 6. Set Close Limit

At Fig:61, press and hold until the door fully closes.

If it overshoots, adjust with .

Press to save. The wizard will then advance to (Fig:62)

## 7. Set Open Limit

At Fig:62, press and hold to raise the door.

If it overshoots, adjust with .

Press to save.

## 8. Profiling

After saving the open limit, DAVE prompts to start the door profiling process (Fig:63), during which it gathers data on the door's travel time and load. Press **CLOSE/DOWN**() to begin profiling. The door will close, open, then close again (Fig:64- Fig:65)

This step must be completed for limits to be stored permanently.

Once profiling completes, the door is ready but remains in dead-man/ constant-contact mode until a safety device is installed (Fig:66).

ACTIVATE KEY SWITCH  
TO ACCESS LIMIT  
SETUP & MENUS

Fig:58

NO TRAVEL LIMITS SET  
 SETUP LIMITS  
 & DOOR WINDUP MODE  
 ACCESS MENUS

Fig:59

SELECT DOOR TYPE  
= STANDARD SECTIONAL  
  
 EDIT DONE

Fig:60

SET CLOSE LIMIT!  
HOLD OR TO DRIVE  
PRESS TO SAVE  
PRESS FOR OPTIONS

Fig:61

SET OPEN LIMIT!  
HOLD OR TO DRIVE  
PRESS TO SAVE  
PRESS FOR OPTIONS

Fig:62

PRESS TO START  
DOOR PROFILING.  
KEEP CLEAR UNTIL  
PROFILING COMPLETE.

Fig:63

DOOR CLOSING  
KEEP CLEAR  
  
DOOR PROFILING...

Fig:64

DOOR OPENING  
KEEP CLEAR  
  
DOOR PROFILING...

Fig:65

NO SAFETY DEVICE!  
TO CLOSE DOOR MUST  
BE CONTINUOUSLY HELD.  
 TO CONTINUE.

Fig:66



# Set pedestrian / part open position

## 1. Move Door to Desired Position

Before programming the new position into memory open it to the desired partially open position.

## 2. Activate the Console

If the console screen is off, press MENU (≡). If it remains off, check the power source.

## 3. Unlock the Key Switch

The key switch must be unlocked to proceed. If locked, the console will prompt you (Fig:67).

## 4. Navigate to Memory Reset & Configure Menu

Press **MENU**(≡) repeatedly until Fig:68 appears. From here toggle through the menu using **OPEN/UP**(↗) or **CLOSE/DOWN**(↘) to reach Fig:69.

## 5. Navigate to Part Open Position Setting

At Fig:69 use **STOP/ENTER**(■) to enter the Memory Reset and Configure Menu. Toggle through the menu using **OPEN/UP**(↗) or **CLOSE/DOWN**(↘) to reach Fig:70.

## 6. Save Part Open Position

At Fig:70 press **STOP/ENTER**(■) to save the current door position as the new Part Open position. At Fig:71 press **STOP/ENTER**(■) to confirm. Fig:72 displays to confirm that the new Part Open Position has been saved to memory.

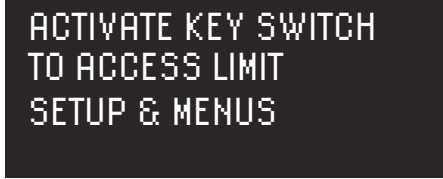

ACTIVATE KEY SWITCH  
TO ACCESS LIMIT  
SETUP & MENUS

Fig:67



1: REMOTE CONTROL  
LEARN MENU  
◀NEXT ■START ≡EXIT

Fig:68



5: MEMORY RESET &  
CONFIGURE MENU  
◀NEXT ■START ≡EXIT

Fig:69

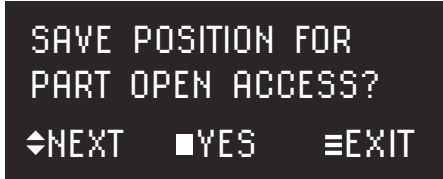

SAVE POSITION FOR  
PART OPEN ACCESS?  
◀NEXT ■YES ≡EXIT

Fig:70

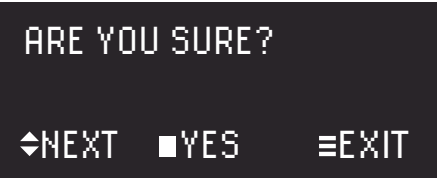

ARE YOU SURE?  
◀NEXT ■YES ≡EXIT

Fig:71



DOOR POSITION SAVED  
FOR PART OPEN ACCESS

Fig:72

# Operator Settings

A full listing of DAVE's extensive control setting options can be found in the "Programming Options Table" on page 62, under 2: SETTINGS AND MODE ADJUSTMENT MENU.

## HOW TO CHANGE DAVE'S CONTROL SETTINGS

### 1. Before You Begin

Ensure DAVE is powered on and connected to a wall console with a working power source. The console must be either wirelessly paired or physically wired to DAVE's control board.



### 2. Activate the Console

If the console screen is off, press . If it remains off, check the power source.



### 3. Unlock the Key Switch

Unlock the key switch to proceed. If locked, the console will prompt you (Fig:73).

### 4. Navigate to Settings and Mode Adjustment Menu

Press  repeatedly until Fig:74 appears. From here toggle through the menu using  or  to reach Fig:75.

### 5. Choose a Setting to Edit

At Fig:75 press . Fig:76 shows the first of the many editable settings that can be accessed via this menu. From here toggle through the menu using  or  to find the setting you wish to edit.

A full listing and overview of each function can be found in under 2:SETTINGS AND MODE ADJUSTMENT MENU in the "Programming Options Table" on page 62.

Some commonly used settings include

- Door Open Speed
- Door Close Speed
- Auto-Close Time
- Safety Device Auto-Close Time
- Safety Device Settings
- Relay Settings

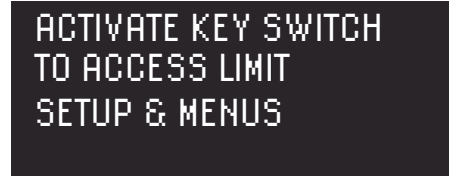

Fig:73

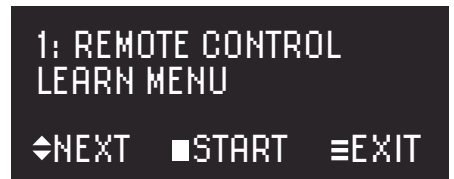

Fig:74

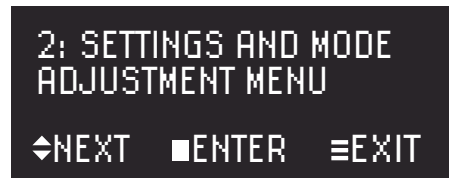

Fig:75



Fig:76

# Resetting to Factory Defaults

## RESET OPTIONS OVERVIEW

Reset functions for the operator and wall console are accessed through the two separate menus shown below.

For descriptions of each function, refer to the full list of DAVE's programming options on page 62.

## MEMORY RESET & CONFIGURE MENU OPTIONS

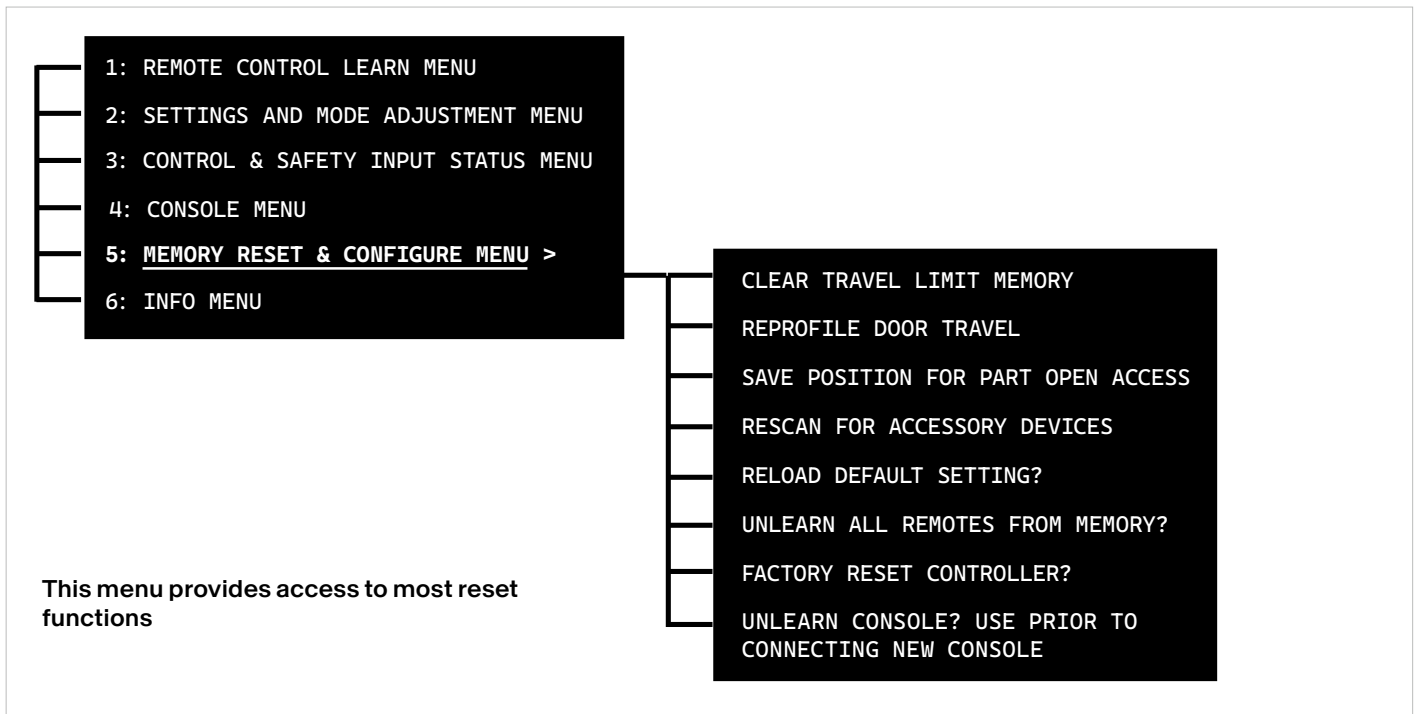

## CONSOLE SETUP & RESET

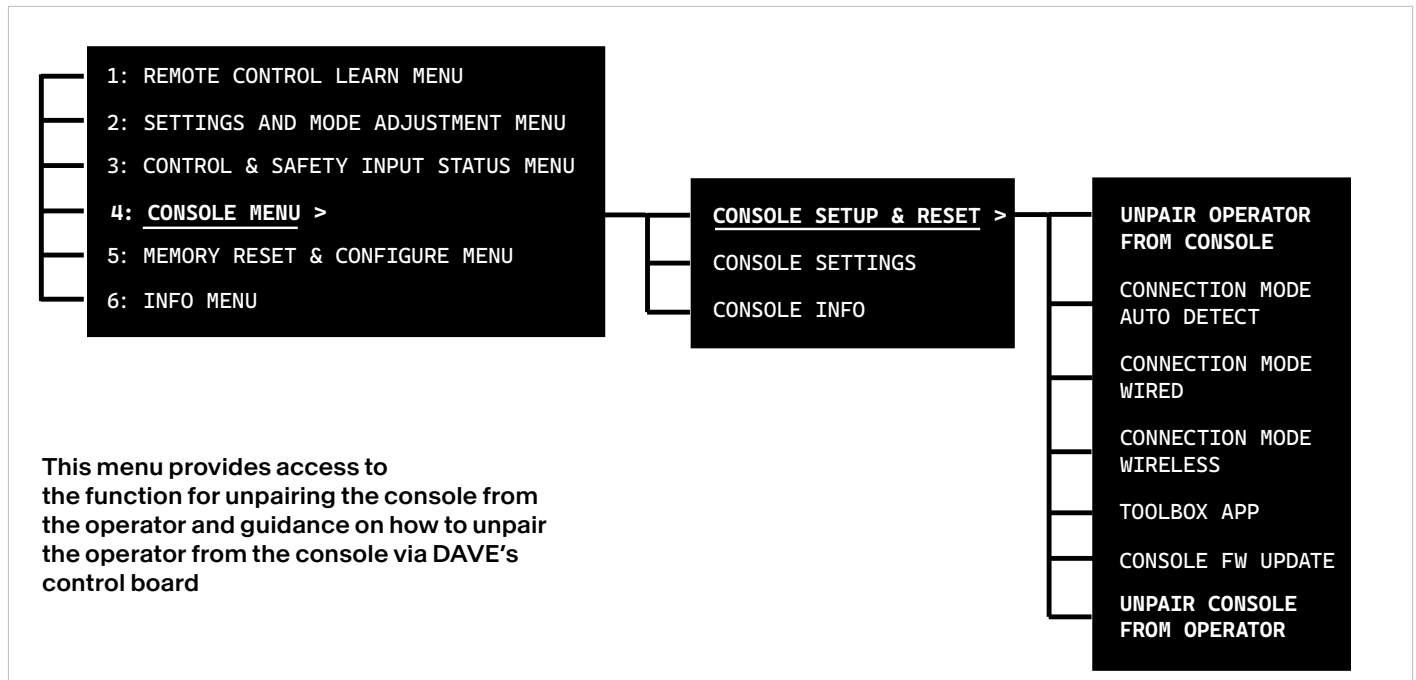

# ACCESSING MEMORY RESET FUNCTIONS

## 1. Activate the Console

If the console screen is off, press MENU (≡). If it remains off, check the power source.

## 2. Unlock the Key Switch

The key switch must be unlocked to proceed. If locked, the console will prompt you (Fig:77).

## 3. Navigate to Memory Reset & Configure Menu

Press ≡ repeatedly until Fig:78 appears. From here toggle through the menu using ▲ or ▼ to reach Fig:79.

## 4. Enter Memory Reset Menu and Choose Setting to Reset

At Fig:79 press ■. Fig:80 shows the first of the various reset functions that can be accessed via this menu. From here toggle through the menu using ▲ or ▼ to find the required reset function.

Descriptions of each function can be found under 5:MEMORY RESET AND CONFIGURE MENU in the "Programming Options Table" on page 62.

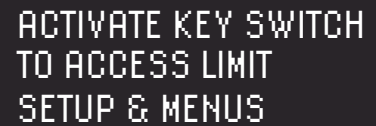

```
ACTIVATE KEY SWITCH
TO ACCESS LIMIT
SETUP & MENUS
```

Fig:77



```
1: REMOTE CONTROL
LEARN MENU

◀NEXT ■START ≡EXIT
```

Fig:78

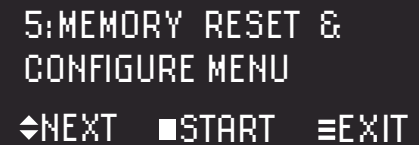

```
5:MEMORY RESET &
CONFIGURE MENU

◀NEXT ■START ≡EXIT
```

Fig:79

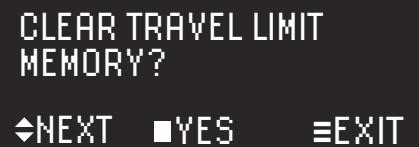

```
CLEAR TRAVEL LIMIT
MEMORY?

◀NEXT ■YES ≡EXIT
```

Fig:80

# Unpair Console From Operator



## 1. Activate the Console

If the console screen is off, press . If it remains off, check the power source.



## 2. Unlock the Key Switch

The key switch must be unlocked to proceed. If locked, the console will prompt you (Fig:81).



## 3. Navigate to Memory Reset & Configure Menu

Press  repeatedly until Fig:82 appears. From here toggle through the menu using  or  to reach Fig:83.



## 4. Navigate to Console Settings & Info

At Fig:83  to enter the Console Settings and Info Menu. Toggle through the menu using  or  to reach Fig:84.

## 5. Navigate to Unpair Console Option

At Fig:84 press  enter the Console Setup & Reset menu. Toggle through the menu using  or  to reach Fig:85.

## 6. Unpair Console from Operator

At Fig:85 press  to initiate the unpairing process. At the confirmation screen Fig:86 press  once again.

Once the console has disconnected, it will restart.

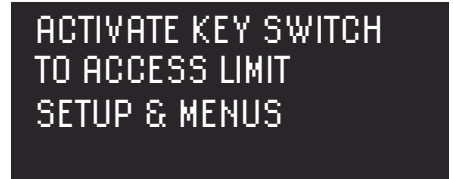

Fig:81

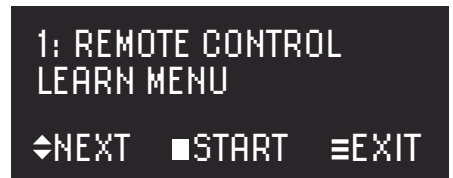

Fig:82

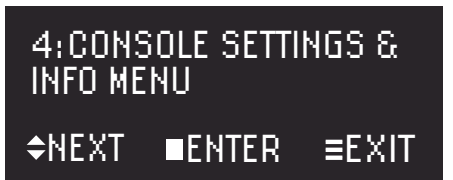

Fig:83

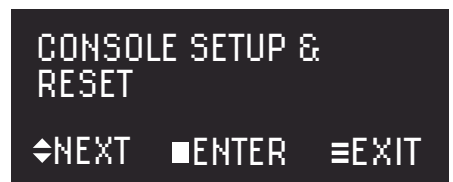

Fig:84



Fig:85

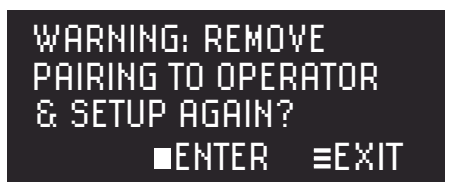

Fig:86

# Programming Options Table

## O. NO TRAVEL LIMITS SET

For configuration of operator on first use, or after factory reset. Use this menu to select door type and select limits.

### O.1. Setup Limits

Set door type and limits.

#### O.1.1. Select door type

Choose between  
STANDARD SECTIONAL  
VERTICAL / HIGH LIFT  
ROLLING STEEL  
CUSTOM

#### O.1.2. Set close limit

Hold  or  to drive, or  to save.

#### O.1.3. Set open limit

### O.2. Door windup mode

For shutters only. Use this mode for winding shutter curtain onto drum during shutter installation.

## 1. REMOTE CONTROL LEARN MENU

Remote Control Learn Menu

### 1.1. Learn remote for open/stop/close

Learn Remote Control for Normal Operation. Command sequence is OPEN / CLOSE / STOP when pressed.

### 1.2. Learn remote for open

Learn Remote Control for Specialised Operation. Command sequence is OPEN only when pressed.

### 1.3. Learn remote for stop

Learn Remote Control for Specialised Operation. Command sequence is STOP only when pressed.

### 1.4. Learn remote for close

Learn Remote Control for Specialised Operation. Command sequence is CLOSE only when pressed.

### 1.5. Learn remote for partial open

Learn Remote Control for Specialised Operation. Command sequence is control of Partial Open (Secondary Limit position) when pressed.

### 1.6. Learn remote for courtesy light

Learn Remote Control for Specialised Operation. Command sequence is to control a light wired through DAVE's Relay Expansion Board.

### 1.7. Learn remote for remote lockout

Learn Remote Control for Specialised Operation. Command sequence is control of Lock out of all stored remote controls when pressed.

### 1.8. Learn remote for auxiliary output

Learn Remote Control for Specialised Operation. Command sequence is control of Auxiliary Output function when wired through DAVE's Relay Expansion Board to control another device.

## 2. SETTINGS AND MODE ADJUSTMENT MENU

## Settings & Mode Adjustment Menu

2.1. Auto-close time (sec) [O=off]	Note Auto-Closing function can only be initiated when Safety Devices are commissioned & functioning. Standard Auto-Close (Timer to Close) Auto Close Functions from fully open position always after timer countdown expires Adjustable in 1 Second increments Default is off Min 0 Seconds Max 255 Seconds
2.2. SD auto-close time (sec) [O=off]	Note Auto-Closing function can only be initiated when PE Beams are commissioned & functioning PE Triggered Auto-Close (Timer to Close) Auto Close Functions only after an interruption of Photo Cells. Without this interruption, countdown timer does not commence. Adjustable in 1 Second increments Default is off Min 0 Seconds Max 255 Seconds
2.3. Courtesy Light timer (sec) 180	Adjustable Light Timer to any Light wired to product (Relay module is required) Adjustable in 1 second increments Default is 180 Seconds Min 0 Seconds Max 255 seconds
2.4. Auxiliary Output time (sec) 1	Adjustable AUX OUTPUT (When wired through DAVE's Relay Expansion Board to control another device) Adjustable in 1 second increments Default is 1 Second Min 0 Seconds Max 255 Seconds
2.5. Close Speed RPM 1500	Adjustable CLOSING SPEED scaled in RPM. Adjustable in 100 RPM increments. Settings depend on the selected door type, e.g. for Rolling Steel doors, Default Opening Speed=1500, Min=700, Max=3000
2.6. Open Speed RPM 1700	Adjustable OPENING SPEED scaled in RPM. Adjustable in 100 RPM increments. Settings depend on the selected door type, e.g. for Rolling Steel doors, Default Opening Speed=1700, Min=700, Max=3000
2.7. Slow Down Rate 250	SOFT STOP CONTROL. Adjusts rate at which door slows to a stop. Decrease the value for a softer stop / more gradual deceleration. Set to maximum value for an immediate stop with no deceleration.
2.8. Speed Up Rate 80	SOFT START CONTROL. Adjusts rate at which door accelerates from stationary to programmed travel speed. Decrease the value for softer start / more gradual acceleration. Set to maximum value to start opening at programmed travel speed.
2.9. Safety Device 1 type off	Safety Device Input number 1 Menu Input Off as default. Option needs to be selected if using input
2.9.1. Safety Device SD1 type SB	Wired Safety Device Selection Option 1 Safety Beam ( AT Brand PE Beams)
2.9.2. Safety Device SD1 type PUL	Wired Safety Device Selection Option 2 Pulse Type ( Miller Edge Safety devices )
2.9.3. Safety Device SD1 type 10K	Wired Safety Device Selection Option 3 : (10K) Ohm Resistor type (Miller Edge Safety Devices )

2.10. Safety Device 2 type off	Safety Device Input number 2 Menu Input Off as default. Option needs to be selected if using input
2.10.1. Safety Device SD2 type SB	Wired Safety Device Selection Option 1 Safety Beam ( AT Brand PE Beams)
2.10.2. Safety Device SD2 type PUL	Wired Safety Device Selection Option 2 Pulse Type ( Miller Edge Safety devices )
2.10.3. Safety Device SD2 type 10K	Wired Safety Device Selection Option 3 10K Ohm Resistor type ( Miller Edge Safety Devices )
2.11. Safety Device 3 type off	Safety Device Input number 3 Menu Input Off as default. Option needs to be selected if using input
2.11.1. Safety Device SD3 type SB	Wired Safety Device Selection Option 1 Safety Beam ( AT Brand PE Beam )
2.11.2. Safety Device SD3 PUL	Wired Safety Device Selection Option 2 Pulse Type ( Miller Edge Safety devices )
2.11.3. Safety Device SD3 type 10K	Wired Safety Device Selection Option 3 10K Ohm Resistor type ( Miller Edge Safety Devices )
2.12. Ignore SD1 for Fire & Part Close = No	For fire & part close cycles customer can choose to ignore signals from safety device SD1
2.13. Ignore SD2 for Fire & Part Close = No	For fire & part close cycles customer can choose to ignore signals from safety device SD2
2.14. Ignore SD3 for Fire & Part Close = No	For fire & part close cycles customer can choose to ignore signals from safety device SD3
2.15. Ignore WPE1 for Fire & Part Close = No	For fire & part close cycles customer can choose to ignore signals from safety device WPE1
2.16. Ignore WPE2 for Fire & Part Close = No	For fire & part close cycles customer can choose to ignore signals from safety device WPE2
2.17. Relay 1 mode light	Relay number 1 Control Menu Modes Default is LIGHT Mode (Wired Courtesy Light)
2.17.1. Relay 1 mode open	Relay active when door is fully open
2.17.2. Relay 1 mode closed	Relay active when door is fully closed
2.17.3. Relay 1 mode part open	Relay active when door is part open
2.17.4. Relay 1 mode part close	Relay active when door is part closed
2.17.5. Relay 1 mode smoke baffle	Relay active when door is at smoke baffle position
2.17.6. Relay 1 mode movement warn	1 HZ Flash when door is moving
2.17.7. Relay 1 mode movement	Relay 1 active while door is moving
2.17.8. Relay 1 mode unattended warn	Pre-drive warning when Smart Phone is enabled
2.17.9. Relay 1 mode AUX output	AUX OUTPUT Specialized custom output for Lights See Installation Guide for more details
2.17.10. Relay 1 mode alert status	Relay activates only in the event of an alert
2.17.11. Relay 1 mode fault status	Relay activates in the event of fault
2.17.12. Relay 1 mode off	Relay is inactive (Disabled)
2.18. Relay 2 mode open	Relay number 2 Control Menu Modes



	Default is OPEN Mode Relay active when door is fully open
2.18.1. Relay 2 mode closed	Relay active when door is fully closed
2.18.2. Relay 2 mode part open	Relay active when door is part open
2.18.3. Relay 2 mode part close	Relay active when door is at part close
2.18.4. Relay 2 mode smoke baffle	Relay active when door is at smoke baffle position.
2.18.5. Relay 2 mode movement warn	1 HZ Flash when door is moving
2.18.6. Relay 2 mode movement	Relay 2 active while door is moving
2.18.7. Relay 2 mode unattended warn	Pre-drive warning when Smart Phone is enabled
2.18.8. Relay 2 mode AUX output	AUX OUTPUT Specialised custom output for Lights.
2.18.9. Relay 2 mode alert status	Relay activates only in the event of alerts
2.18.10. Relay 2 mode fault status	Relay activates in the event of a fault
2.18.11. Relay 2 mode off	Relay is inactive (Disabled)
2.18.12. Relay 2 mode light	Relay is active like a light switch
2.19. Relay 3 mode aux output	Relay number 3 Control Menu Modes Default is AUX Mode.
2.19.1. Relay 3 mode alert status	Relay activates only in the event of alerts
2.19.2. Relay 3 mode fault status	Relay activates in the event of a fault
2.19.3. Relay 3 mode off	Relay is inactive (Disabled)
2.19.4. Relay 3 mode light	Relay is active like a light switch
2.19.5. Relay 3 mode open	Relay active when door is fully open
2.19.6. Relay 3 mode closed	Relay active when door is fully closed
2.19.7. Relay 3 mode part open	Relay active when door is part open
2.19.8. Relay 3 mode part closed	Relay active when door is part closed
2.19.9. Relay 3 mode smoke baffle	Relay active when door is at smoke baffle position
2.19.10. Relay 3 mode movement warn	1 HZ Flash when door is moving
2.19.11. Relay 3 mode movement	Relay 3 active while door is moving
2.19.12. Relay 3 mode unattended warn	Pre-drive warning when Smart Phone is enabled
2.20. Relay 4 mode movement	Relay number 4 Control Menu Modes Default is MOVEMENT WARNING Relay only activates with a 1HZ Flash when door is moving
2.20.1. Relay 4 mode unattended warn	Pre-drive warning when Smart Phone is enabled
2.20.2. Relay 4 mode AUX output	Specialised custom output for Lights See Installation Guide for more details
2.20.3. Relay 4 mode alert status	Relay activates only in the event of alerts

2.20.4. Relay 3 mode fault status	Relay activates in the event of a fault
2.20.5. Relay 4 mode off	Relay is inactive (Disabled)
2.20.6. Relay 4 mode light	Relay is active like a light switch
2.20.7. Relay 4 mode open	Relay active when door is fully open
2.20.8. Relay 4 mode closed	Relay active when door is fully closed
2.20.9. Relay 4 mode part open	Relay active when door is part open
2.20.10. Relay 4 mode part close	Relay active when door is part closed
2.20.11. Relay 4 mode smoke baffle	Relay active when door is at smoke baffle position
2.20.12. Relay 4 mode movement warn	1Hz flash when door is moving
2.21. GPA input function part open	General Purpose Accessory Input Menu Default is PARTIAL OPENING (PEDESTRIAN) When wired to this input Command reflects PARTIAL OPENING setting
2.21.1. GPA input function part close	When this wired input activates, door will move to part closed position
2.21.2. GPA input function swipe	When swipe input activates, the door will open and remain partly open until swipe input is deactivated
2.21.3. GPA function off	GPA function off (Inactive)
2.22. GPB input function swipe	When swipe input activates, the door will open and stay open until swipe input is deactivated
2.23. GPB input function fire: open or close	Activation of GPB will cause the door to open or close to the smoke baffle position
2.24. GPB input function fire: close only	Activation of GPB will cause the door to only close to smoke baffle position.
2.25. GPB input function fire alarm open or close	Normally closed contact with 10k resistor across contact is used for this function. When activated door will open or close to smoke baffle position.
2.26. GPB input function fire alarm not closed	Normally closed contact with 10k resistor across contact is used for this function. When activated door will only close to smoke baffle position.
2.27. GPB input function off	GPB is deactivated
2.28. Pre close warning off	Pre Drive CLOSE WARNING when DAVE'S relay expansion board is used. Menu Default is OFF
2.28.1. Pre close warning on	Pre-drive CLOSE WARNING when DAVE'S relay expansion board is used: This feature can be used for a "keep clear door is about to close" warning.
2.29. Maintenance cycle preset	Service Alert in Cycles (Preset) Preloaded Service Alert in quantity of cycles Adjustable in 1 Cycle increments Default is 0 (disabled) Minimum is 0 Cycles Maximum is 65535 Cycles

---

### 3. CONTROL AND SAFETY INPUT STATUS MENU

Diagnostics Menu for Control & Safety Inputs

---

#### 3.1. Control input status

Diagnostic feed relating to wired inputs  
LEGEND-Text is Lower Case = input OK  
LEGEND-Text is UPPER CASE= Input fault recognized  
Guide to Input abbreviations  
stp=Stop  
opn=Open  
cls=Close  
osc=Open Stop Close  
gpa=General Purpose input A  
gpb=General Purpose input B  
int= interlock input  
ten= cable tension input  
man= manual operation

---

#### 3.2. Safety devices status

Status of Safety Device menu  
Reports on Active or Inactive ON /OFF prompt  
Reports on Safety Device inputs  
Legend for Input Abbreviations  
SD1=Safety Device input 1  
SD2=Safety Device input 2  
SD3=Safety Device input 3

---

### 4. CONSOLE MENU

---

#### 4.1. Console settings

Console Settings menu

---

##### 4.1.1. Wake mode sleep

Console Battery Power Saving Mode Settings  
Default setting is WAKE MODE SLEEP (See manual for expanded view)

---

##### 4.1.1.1. Sleep [power saver]

WAKE ON MENU PRESS SLEEP MODE. The highest Power saving mode. Console wakes up only when menu button is pressed

---

##### 4.1.1.2. Notify [high power] wake on any change

NOTIFY. The highest power consumption mode. Console wakes up on any change or action to console

---

##### 4.1.1.3. Interact [balanced] wake on console use

INTERACT The balanced power consumption mode Console wakes up only when console is used

---

##### 4.1.2. Screen time out (secs) 20

Time Out Period until LCD turns off  
Adjustable in 1 Second increments  
Default is 20 Seconds  
Minimum 5 Seconds Maximum 120 Seconds

---

##### 4.1.3. Screen contrast 40

Contrast (Brightness) of LCD  
Adjustable in 1 contrast ratio unit increments  
Default is 40 units  
Minimum 1 unit - Maximum 100 units

4.2. Console info	Console Information Menu
4.2.1. Power mode battery OK	Status Check Battery Power Mode Check & Test
4.2.2. Connection state wireless	Status Check of connection of console to Drive Unit Wired or Wireless
4.2.3. Console Version x.x.x	Version of Console firmware
4.2.4. Comms Version x.x.x	Communications protocol version
4.3. Console setup and reset	Console Set Up & Reset Menu
4.3.1. Unpair operator from console	<p>Clear and reset Console with factory reset back to out of box condition. All the including limits, door type and speed are retained by the operator.</p> <p>Note this operation does not fully break the bonding between the operator and Console. The operator will still retain the Console's unique ID in memory and can only be re-paired with this Console.</p> <p>To remove the Console's unique ID from the operator's memory, see item 4.3.6 Unpair Console from Operator.</p>
4.3.2. Connection mode wireless	Prompt that in wired Console option Mode is Auto Detected & Set (See manual for expanded view)
4.3.3. Toolbox App	Toolbox app will be used to update DAVE's firmware via toolbox phone app
4.3.4. Console FW Update	Phone app can be used to update Console firmware
4.3.5. Comms FW Update	Phone app will be used to update DAVE's communications firmware
4.3.6. Unpair console from operator	<p>Clear and reset Bluetooth Bond (Sync) between Console and Drive Unit.</p> <p>Provides instructions for removing the Console's unique ID from the operator's memory via the control board. This step is necessary if replacing the console for any reason.</p>

## 5. MEMORY RESET & CONFIGURE MENU

## MEMORY RESETS MENU

5.1. Clear travel limit memory	Clear all Travel Limits memory. Awaits new limit set up procedure to be completed
5.2. Reprofile door travel	Reprofile Function. Clears all force characteristics in memory and recalibrates new door requirements Operates 3 automatic operations to complete this reprofiling
5.3. Save position for part open access	Set up of limit position for PART OPEN (Pedestrian Access)
5.4. Save position for part close access	Setup / save limit position for part close access
5.5. Save position for smoke baffle access	Setup / save limit position for smoke baffle access
5.6. Rescan for accessory devices?	Rescan function Electronic clear and re -sync of wireless devices Used when connecting and reconnection of wireless base stations
5.7. Reload default settings?	Reload Default Settings in power drive memory
5.8. Unlearn all remotes from memory	Clear Receiver Memory Erase all stored remote controls from receiver memory locations
5.9. Factory reset controller?	This will cause all control memory to be reset to factory defaults, Excluding remotes, history log and lifetime cycle counter
5.10. Unlearn Console?	Use prior to connecting new console. Disables RF communications from console, i.e. Up (▲) Down (▼) & Stop (■). All settings retained on console and operator.

## 6. INFORMATION MENU

Information Menu Details of Drive Unit build characteristics diagnostics and operational history

6.1. Model novus 1V1	Version of Main PCB
6.2. Firmware fw Version#	Version of Main PCB firmware
6.3. Build (MMM DD YYYY)	Build date of Firmware
6.4. Open cycles	Operational history Open Cycles in units
6.5. Close cycles	Operational history Close Cycles in units
6.6. Maintenance due in (cycles)	Cycle Countdown to Next Service Displays how many cycles remain until the next service. 0 = Service Now Due Linked to Maintenance Cycle preset. Disabled by default To enable: 1) Load the maintenance cycle preset 2) Enter the number of cycles before service is due.
6.7. Lifetime cycles	Operational Life cycles in units This figure cannot be edited
6.8. Open stalls	Diagnostics Open Stall. A stall can be detected if the door is jammed

6.9. Close stalls	Diagnostics Close Stall A stall can be detected if the Door is Jammed
6.10. Direction faults	Diagnostics Direction Fault Creation of Limit positioning issues Issue detected at SureTrack™ positioning encoder or Harness to SureTrack™ positioning encoder
6.11. Position faults	Diagnostics position fault Creation of Limit positioning issues Issue detected at SureTrack™ positioning encoder or Harness to SureTrack™ positioning encoder
6.12. Balance alert trips	This counter indicates how many times balance alert trip was triggered. Balance alert trips when VBUS exceeds 440volts for 1 second
6.13. Balance alert cycles	Number of cycles completed after balance alert was triggered without resetting
6.14. Balance warning trips	This counter indicates how many times balance warning trips was triggered. Balance warning trips when VBUS exceeds 460volts for 1 second
6.15. Balance warning cycles	Number of cycles completed after balance warning was triggered
6.16. Open position count	Limit assembly counter which control travel distance of the door
6.17. Close travel time	Shows the time in seconds for the door to travel between its open and close limits
6.18. Open travel time	Shows the time in seconds for the door to travel between its close and open limits
6.19. Event history	Full event log of last 90 events.

## **8. SAFETY DEVICES AND OTHER CONTROL INPUTS**

# Safety Device Setup

To meet international safety standards, DAVE must have a working safety device during normal operation. If no safety device is connected, DAVE switches to Dead-Man (Constant-Contact) mode.

As a Wireless-First device, DAVE supports both wireless and wired safety devices.

## Connecting Wireless Safety Beams

Follow these steps to install the base station unit used with all Automatic Technology wireless safety beams. Refer to the safety beam instruction manual for complete instructions on how to install and configure the safety beam kit.

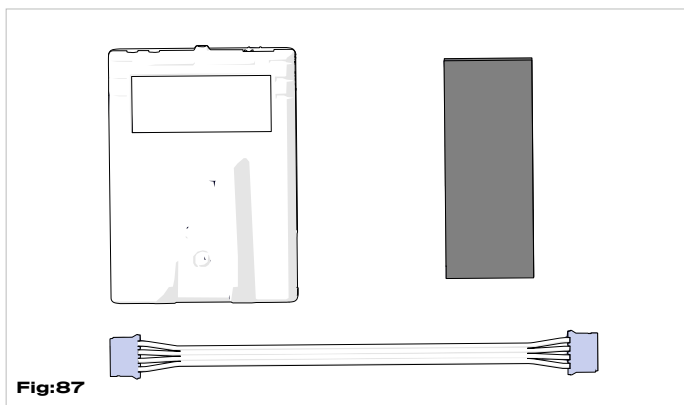

### 1. Pre-requisites (Fig:87)

Use the supplied self-adhesive hook-and loop strip and 4 pin harness. Both items are included in the accessories envelope for Part No.101510 and the safety beam kit for Part No.101511.

### 2. Open Control Board Access Cover

Refer to **Removing Main Control Board Access Cover on page 37**.

### 3. Affix Self-Adhesive Hook-and-Loop Strips (Fig:88)

Separate the hook-and-loop strips.

Stick one piece to the base station and the other to the inside of the control board access door.

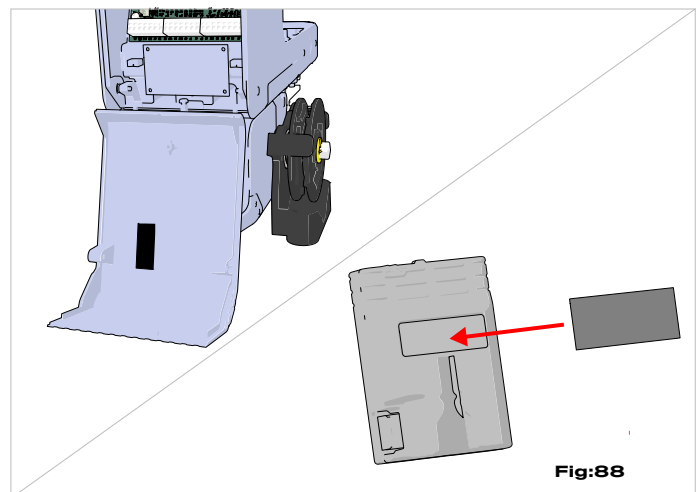

### 4. Attach Base Station to Inside of Main Control Board Access Door(Fig:89)

Align the hook and loop strips to ensure a good grip and attach the base station to the access door.

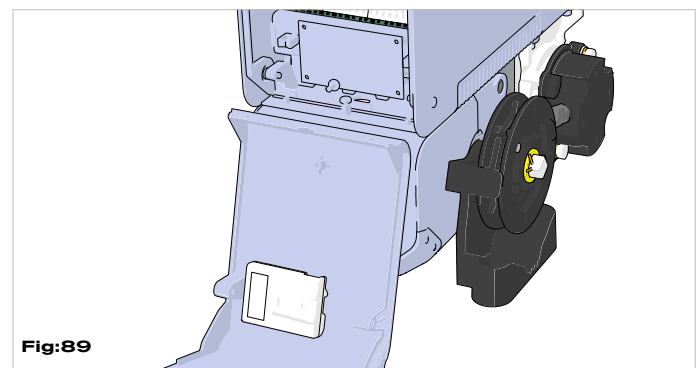



## 5. Connect Harness

Connect one end of the harness to the base station (Fig:90) and the other end to either of the 2 ports marked ACCESSORIES on the main control board (Fig:91)

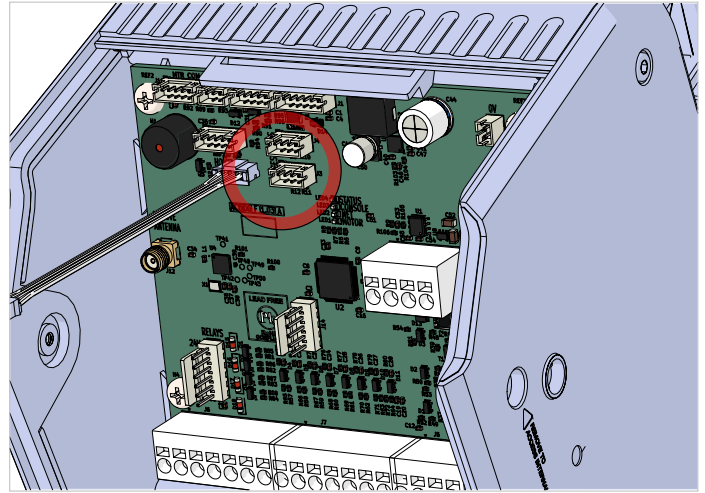

Fig:91

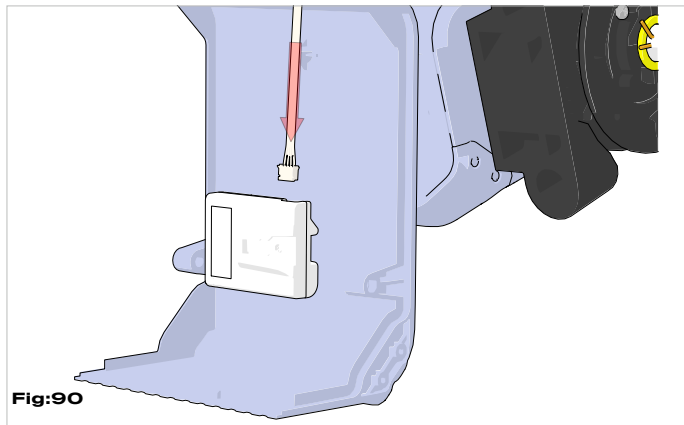

Fig:90

## 6. Replace the Control Board Access Door (Fig:86)

Replace the door by following the steps shown in **Removing Main Control Board Access Cover on page 37** in reverse order.

Reinsert the screws to secure it.

## 7. Automatic Detection

DAVE will automatically detect the wireless base station.

No extra setup is needed unless you're replacing a wired or faulty safety beam see Rescan For Accessory Devices (point 5.6 on page 69 in the Programming Options Table).

# Wired Safety Device Wiring Diagrams

## AUTOMATIC TECHNOLOGY SAFETY DEVICES

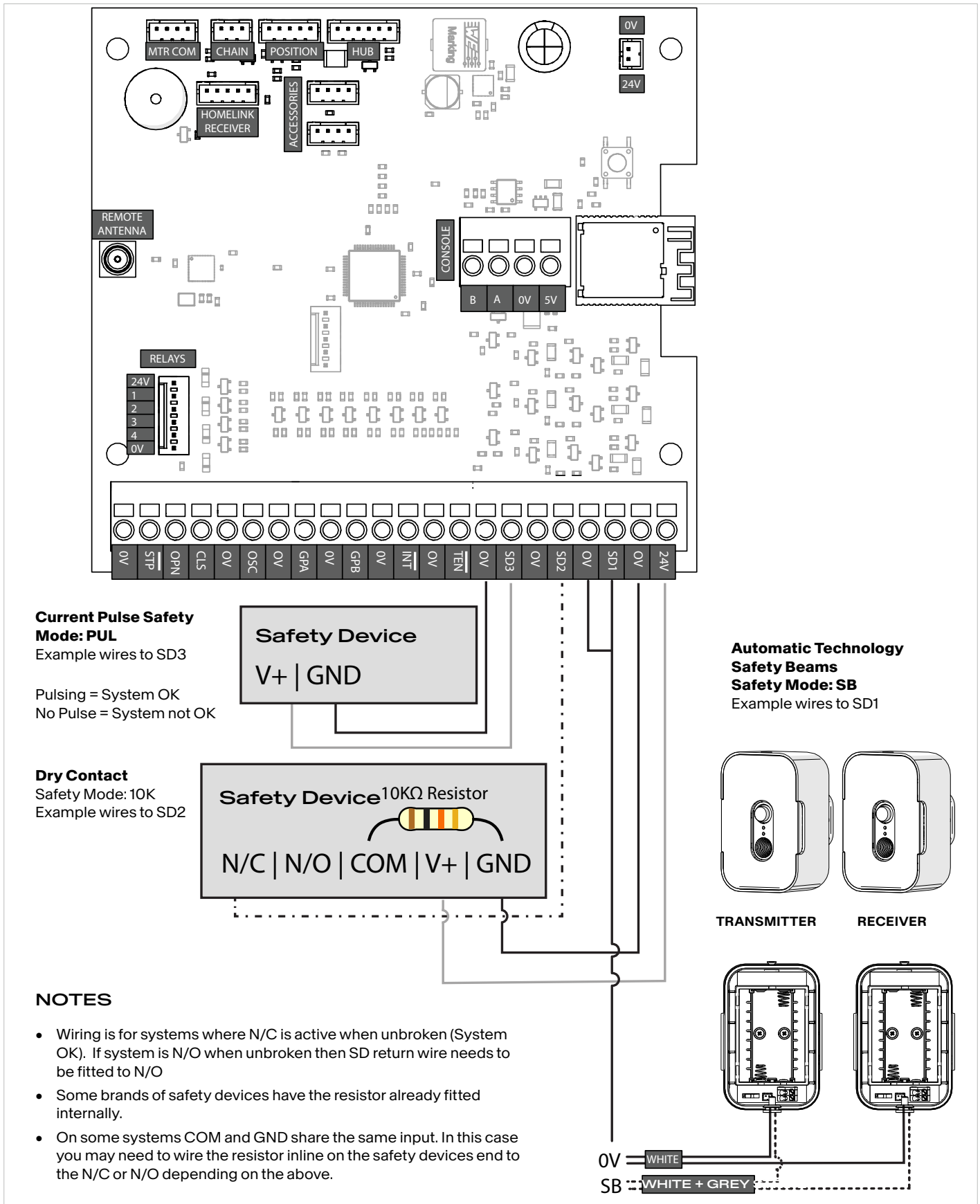

# MILLER EDGE SAFETY DEVICES

## RECEIVER & TRANSMITTER BEAMS

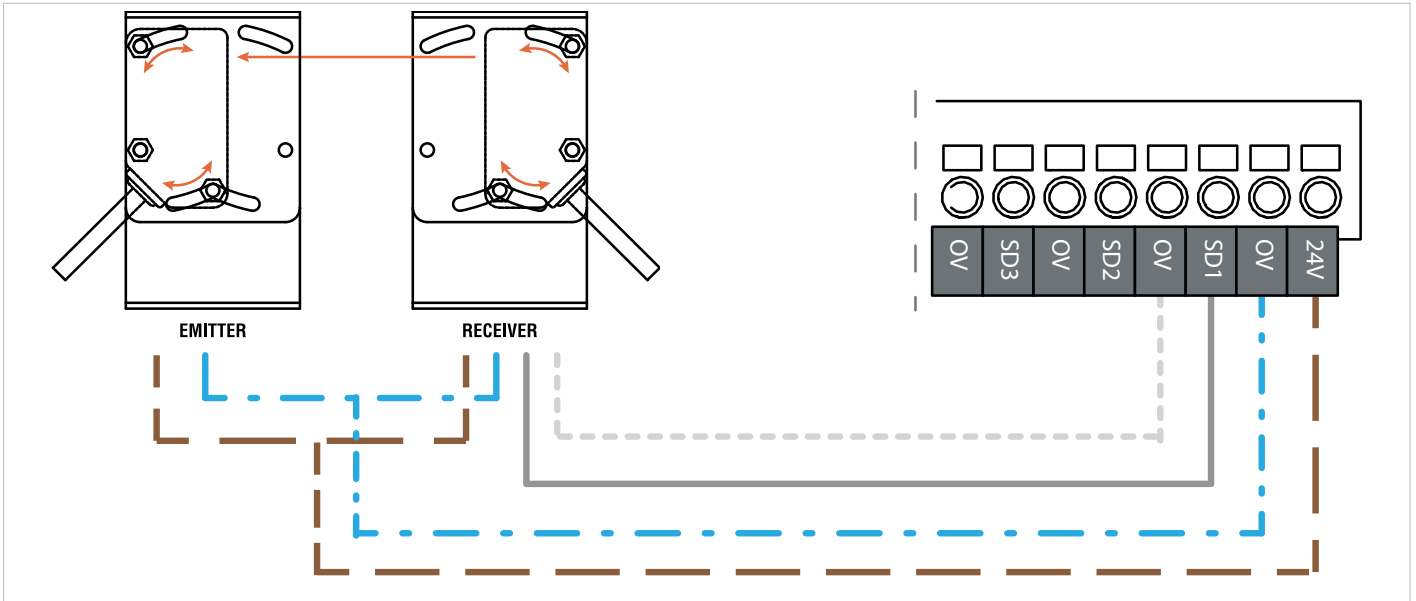

OG-R-K10 **OptiGuard®** Monitored 10K  
Set SD Mode to 10K

## REFLECTOR BEAM

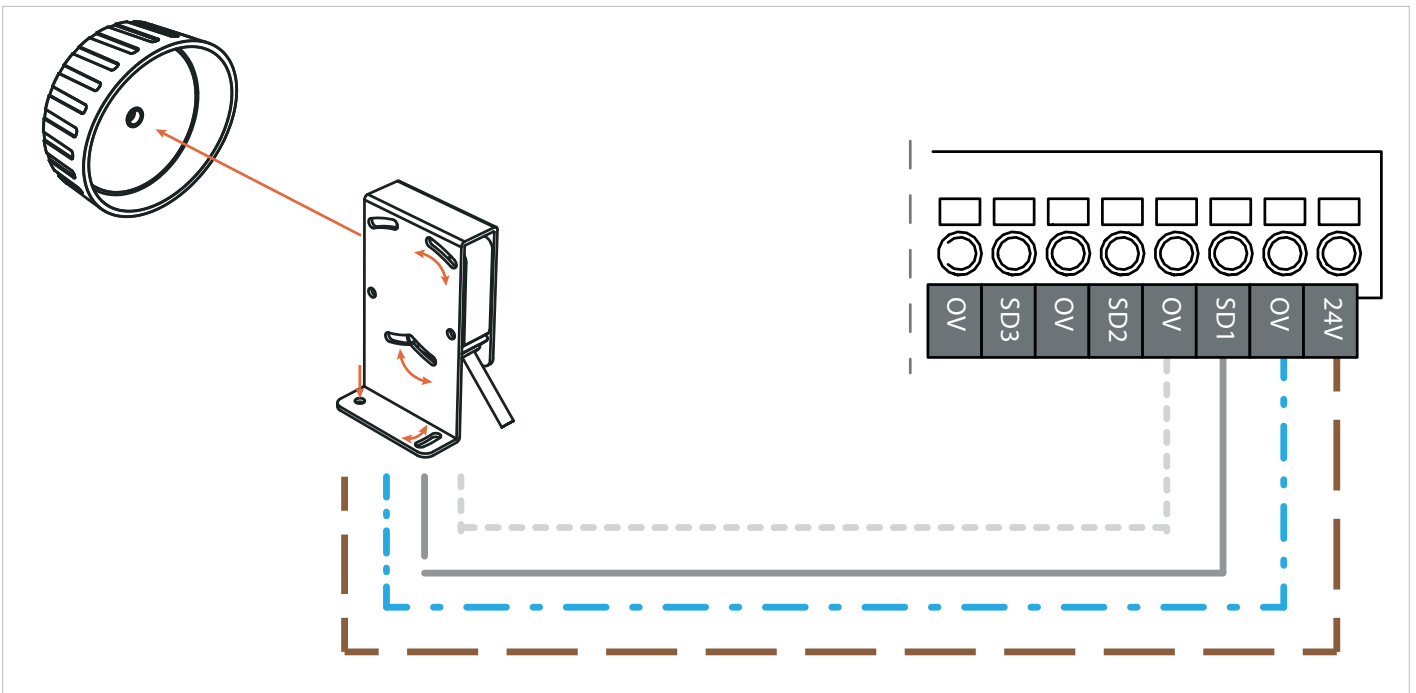

TG-R-K10 **TruGuard® Reflective**  
Set SD Mode to 10K

# LIGHT CURTAINS

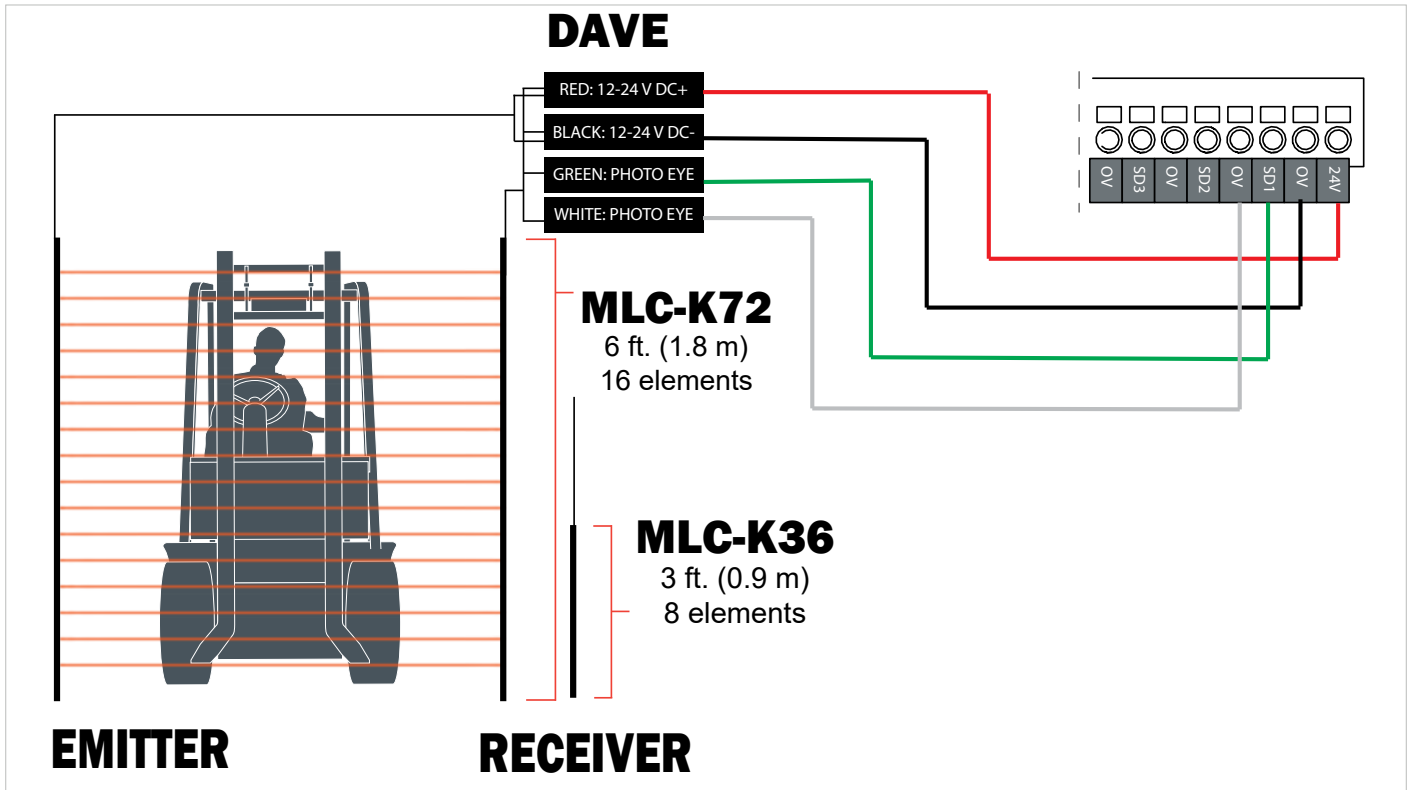

SET SD MODE TO PUL

# Fire System Input

## Standard Fire Alarm Configuration

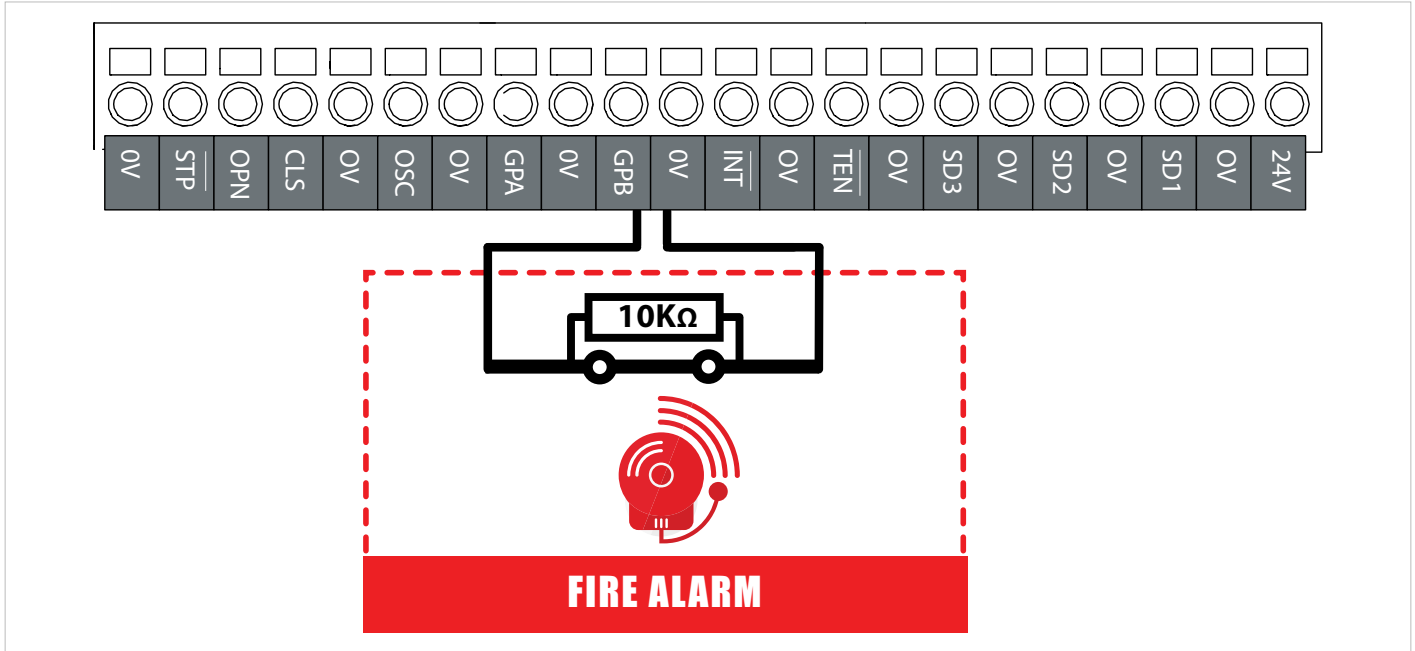

**NORMALLY CLOSED SWITCH AND 10KΩ BLEEDER RESISTOR**  
Door moves to smoke baffle position when alarm is activated

## Standard Fire Alarm Switch Configuration

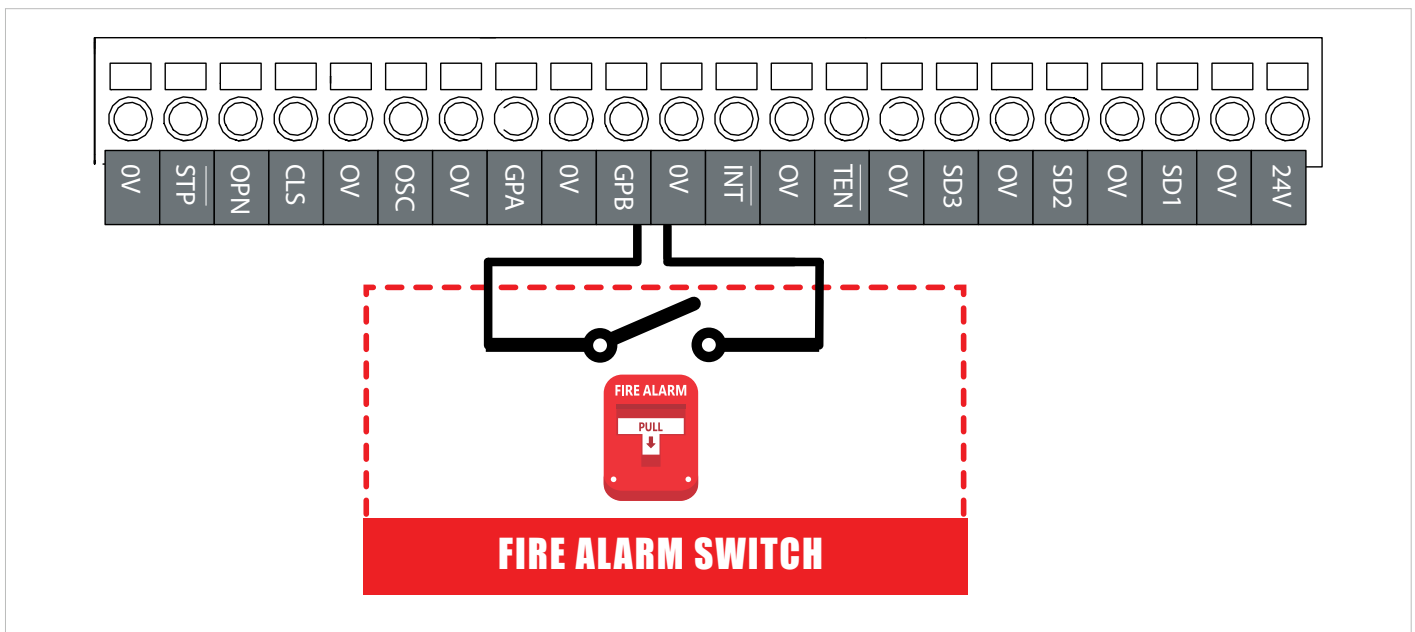

**ACTUATOR SWITCH NORMALLY OPEN**  
Door moves to smoke baffle position when switch is activated

# Fire Input & Function Overview

---

The following outlines the key fire-related input functions supported by DAVE. Each function is triggered via GPA or GPB input, and links to specific door behaviours. For setup details, refer to Programming Options Table on page 62

## FIRE ALARM – NOT CLOSE

Moves the door to the **Smoke Baffle Position** only if it is not already closed.

When released, the door will **open** if above the smoke baffle.

Triggered via **GPB input** with 10K resistor.

Set the position using:

→ **5.5\* Save position for smoke baffle access**

Safety device behaviour is configured in:

→ **2.10–2.14\* Ignore SDx/WPE for Fire & Part Close**

## FIRE ALARM

Drives the door to the Smoke Baffle Position, regardless of current position.

When released, the door will open.

Triggered via **GPB input** with 10K resistor.

Refer to:

→ **2.23\* GPB input function fire alarm open or close**

→ **5.5\* Save position for smoke baffle access**

## FIRE CLOSE

Closes the door to the **Smoke Baffle Position** only.

If already at that position, input is ignored.

Triggered via **GPB input**.

Refer to:

→ **2.22\* GPB input function fire: close only**

→ **5.5\* Save position for smoke baffle access**

## FIRE

Opens or closes the door to the **Smoke Baffle Position**.

If already at that position, input is ignored.

Triggered via **GPB input**.

Refer to:

→ **2.21\* GPB input function fire: open or close**

→ **5.5\* Save position for smoke baffle access**

\* See Programming Options Table on page 62

# Access Devices

## Keypads

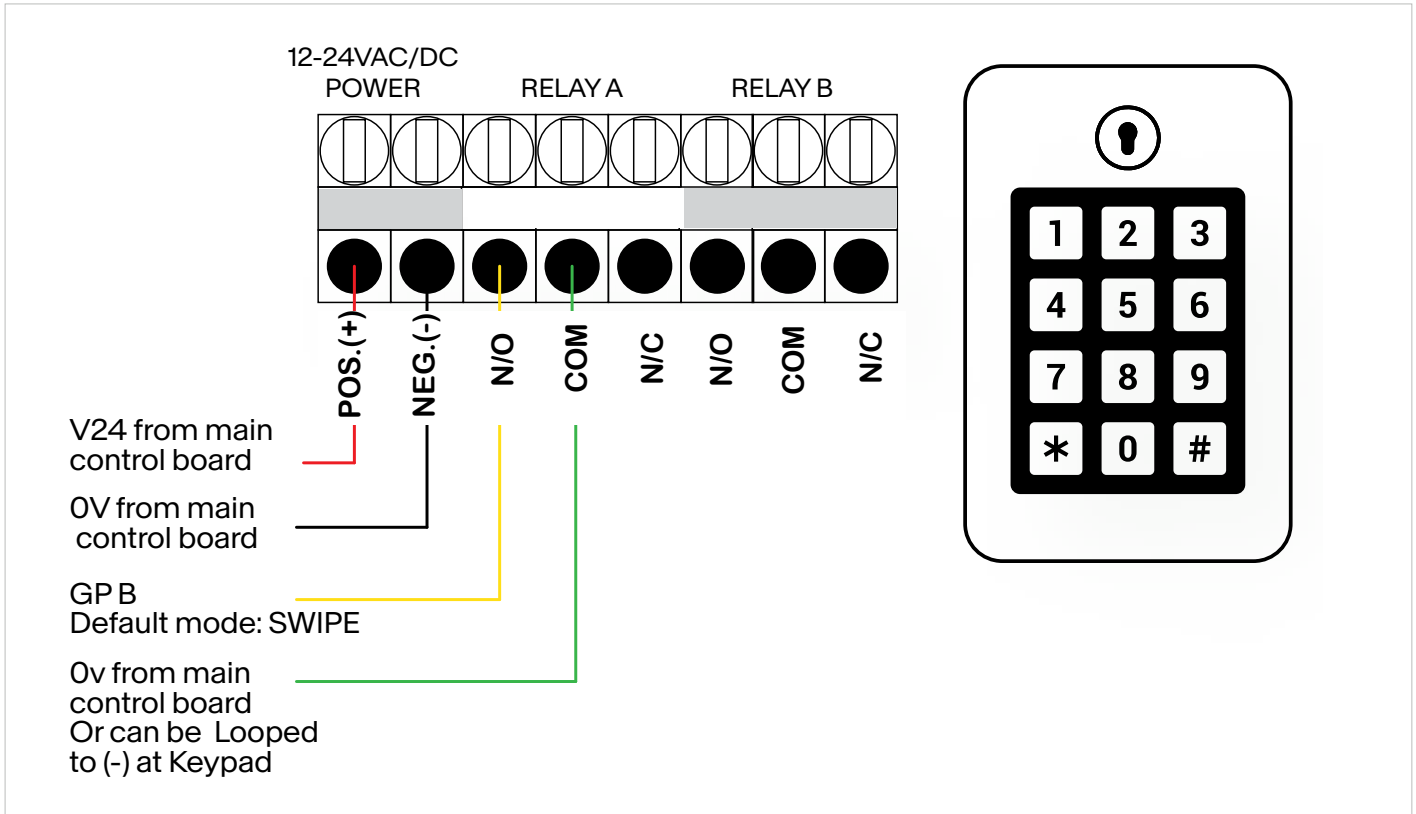

### TYPICAL KEYPAD WIRING CONFIGURATION.

Keypad relay outputs vary from one model to another. Please consult your keypad manual for guidance on wiring and how to set up access codes.

# Loop Detectors

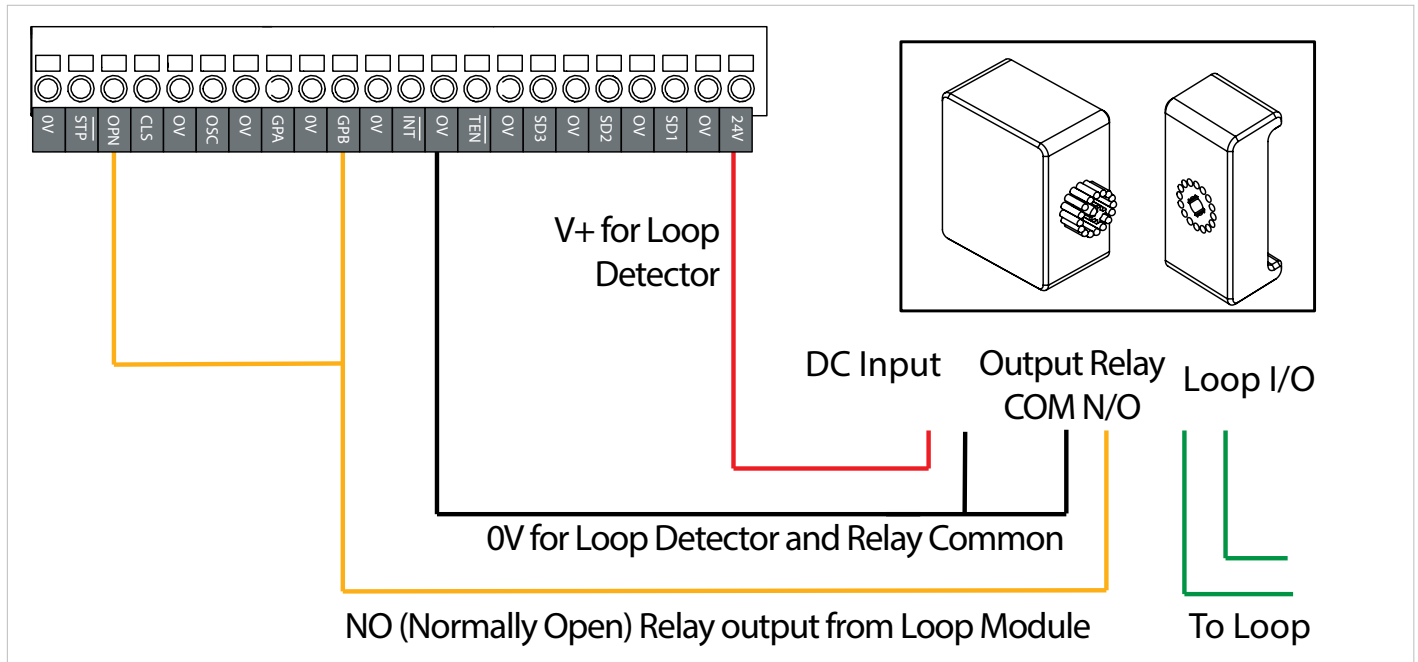

Loop detectors often employ a relay output. This wiring diagram shows a typical configuration for a loop detector with a relay output.

Make sure to consult the instruction manual for your loop device for specific configuration details.

## Wiring Options

- Connect to either the GPB or GPA input and set whichever input you choose to “Swipe” mode.
- The default setting for GPB is “Swipe” mode.
- If neither GPB nor GPA is available, the OPN input can also be used.



# External Receivers

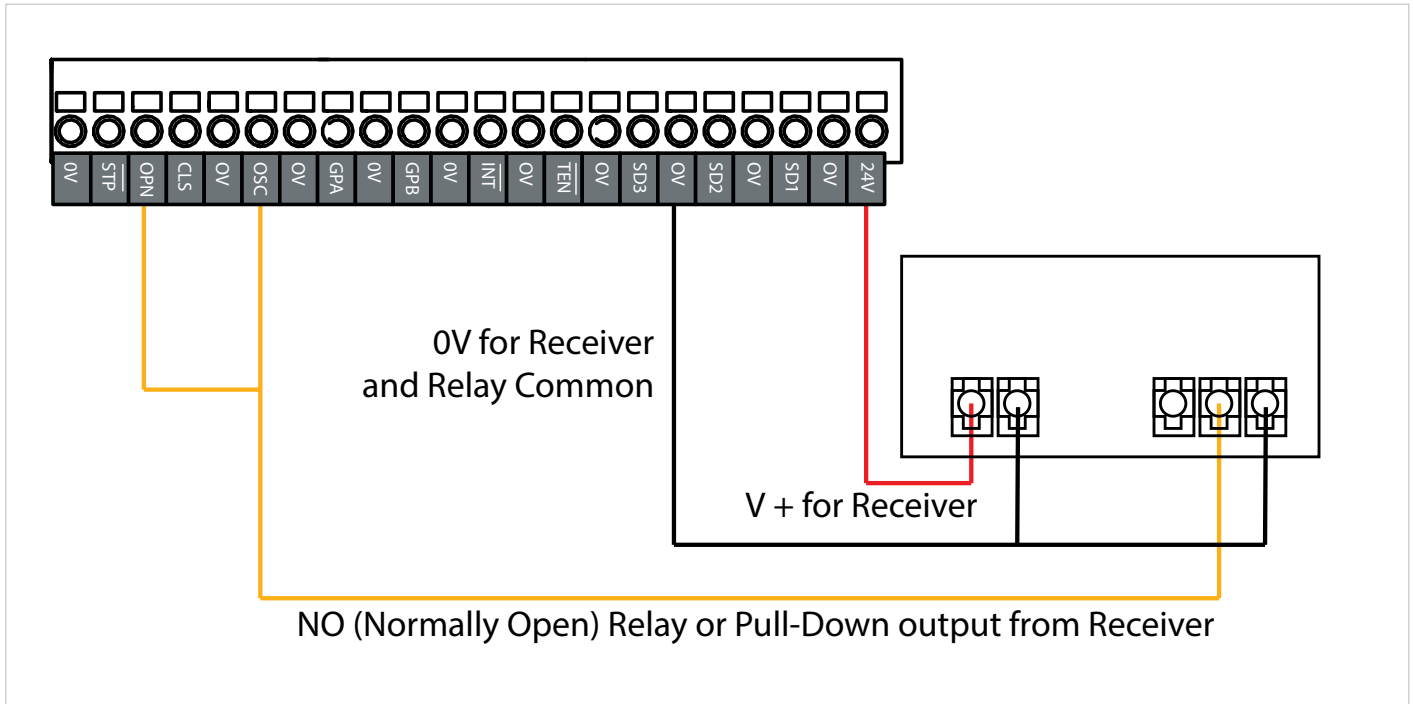

Use an external receiver if you need to interface with 3rd party remote controls, or need more remotes than DAVE's onboard 63 remote memory capacity.

Wiring diagram for AT FHCRX Single Channel External Receiver

Relays that employ a pull-down output rather than relay do not require a Relay Common/COM connection.

DAVE only supports devices that run off a 24VDC power supply. Devices requiring a voltage other than 24V must be connected to an external power supply.

Before connecting an external receiver please ensure its relay/pull-down outputs are suited to 5V signals.

## **9. DAVE'S RELAY EXPANSION BOARD**

# Relay Expansion Board Overview

**DAVE's Relay Expansion Board (part no 101960, sold separately) provides 4 relay modules for controlling external devices. Each relay module can be programmed separately via the Wall Console. Any device requiring a status output from DAVE can be operated via a dry contact**

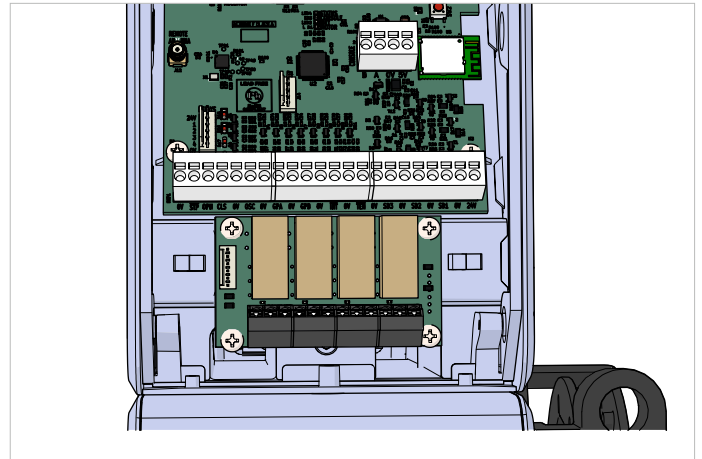
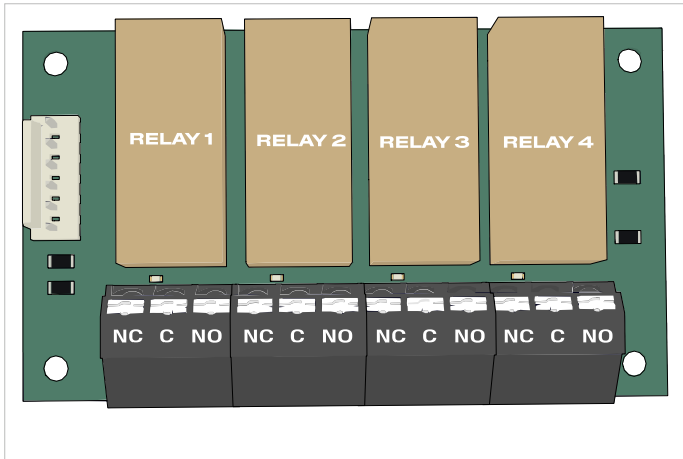

## FEATURES

DAVE's Relay Expansion Board comprises 4 programmable relays, each with 3 dry contacts as shown.

- Normally Open - NO
- Common - C
- Normally Closed - NC

The board supports control of devices operating on 12V-24VDC or up to 240VAC.

## PROGRAMMING

Please refer to Programming Option Table, points 2.17 - 2.20 on page 65.

## APPLICATIONS

- Traffic lights
- Flashing warning lights
- Sirens
- Fire alarm system outputs
- Access control systems (outputs)
- Emergency stop buttons
- Door interlocks

## INSTALLATION

Please refer to the instruction manual supplied with the Relay Expansion Board kit.

# Relay Board Wiring Examples

## Traffic lights

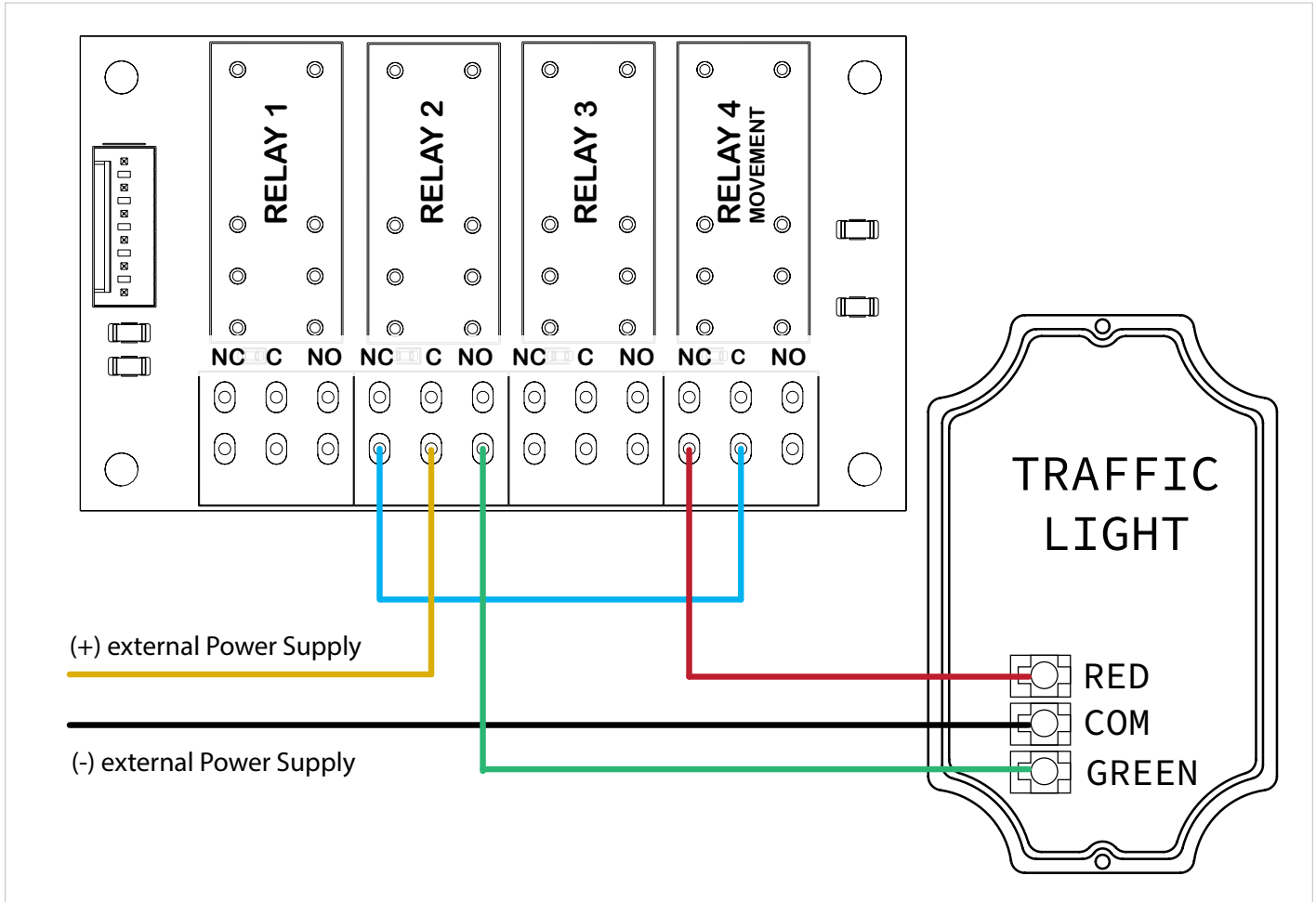

### Light Operation Based on Shown Circuit

- Red Light is active if operator IS NOT fully open
- Red Light is flashing when operator is driving
- Green Light is on when door is fully open.

# Static / Strobing Lights and Sounders

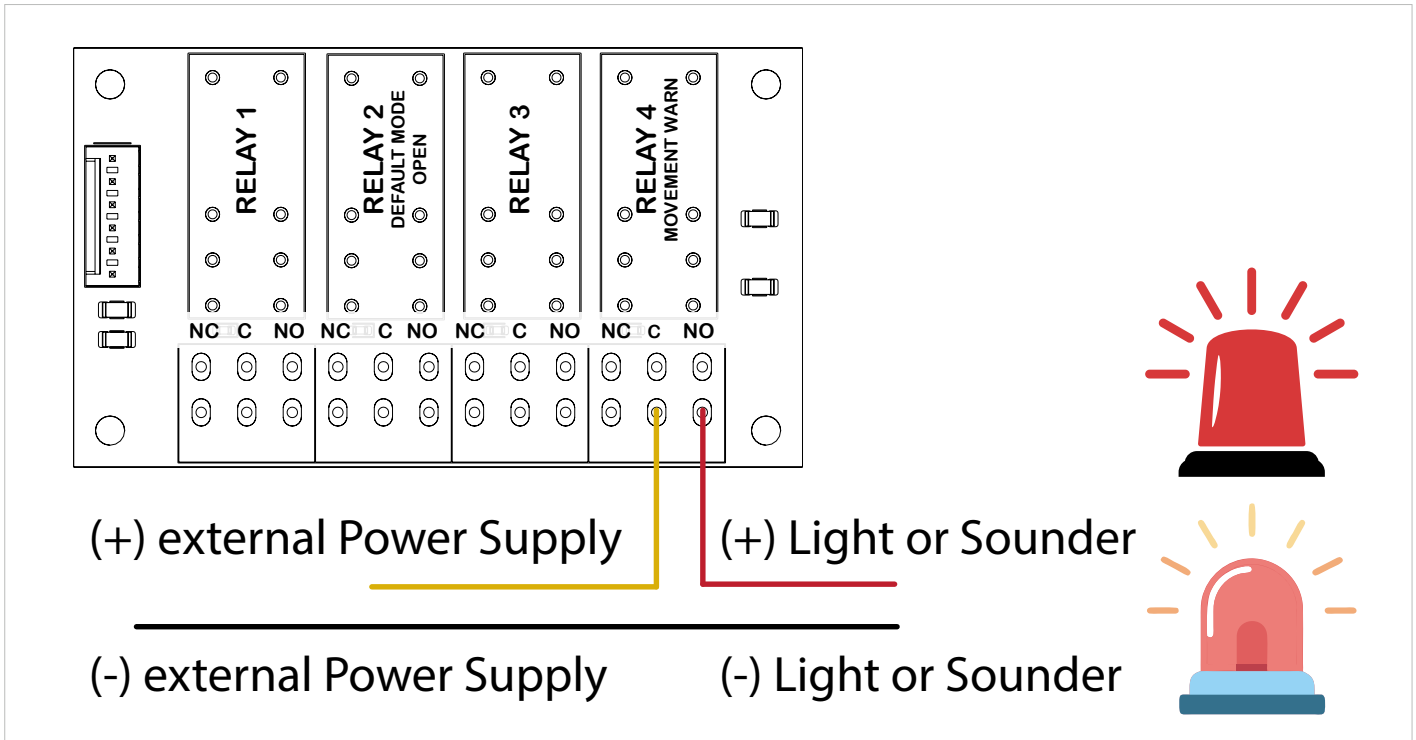

The relay settings offer 3 movement options for warning light or sounder configuration:

1. "MOVEMENT" holds the relay active for the entire cycle (default mode for Relay 4)
2. "MOVEMENT WARN", pulses the relay at 1Hz throughout the entire cycle
3. "UNATTENDED WARN" activates for 3 seconds before the start of a cycle

For:

- Static Lights use "MOVEMENT"
- Lights or sounders with built in strobing action use "MOVEMENT"
- Static lights/sounders that rely on the power supply for strobing action use "MOVEMENT WARN"

# 10. MAINTENANCE & SUPPORT

# Door Service Alerts

DAVE's got brains. His onboard system—powered by ProfileIQ™—keeps an eye on how your door's running.

It tracks changes over time, spots when things start to go a bit off, e.g. early signs of wear, and gives you a heads-up before it turns into a bigger issue.

You'll get three clear alerts when it's time to give the door a once-over. No guesswork. No dramas.

## DOOR BALANCE ALERT

Triggered when the system detects a moderate imbalance during the door's normal operation. The door remains fully operable, and the alert stays visible until the user dismisses it by holding the ■ on the console, or the travel limits are reset.

- **Door Status:** Operates normally.
- **LED Behaviour:** Console LED flashes.
- **Relay Output:** Alert Status relay is activated.
- **Controller Logs:**
  - Counts number of ALERT activations.
  - Tracks cycles with ALERT mode active.
- **User Action:** Press STOP while the door is idle to clear the alert. If warnings persist contact your door maintenance technician and ask for the door to be serviced.

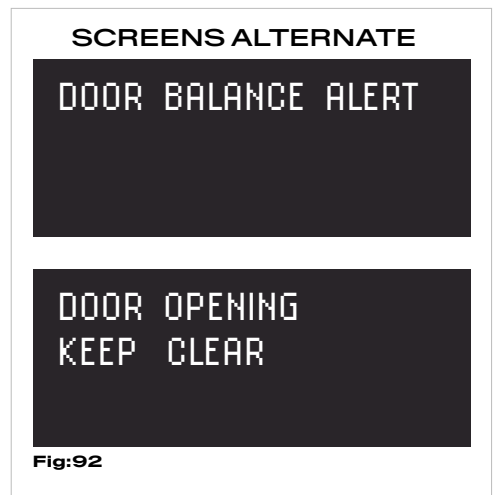

## DOOR BALANCE WARNING

Triggered by a significant imbalance that causes the door to stop mid-cycle. The system enters dead-man / constant-contact mode. The door requires servicing. To exit this mode and restore normal operation, a door maintenance technician must service the door and reset the travel limits.

- **Door Status:** Door stops. Closing requires constant pressure on a close input or remote.
- **LED Behaviour:** Console LED flashes.
- **Relay Output:** Alert Status relay is activated.
- **Controller Logs:**
  - Counts number of WARNING activations.
  - Tracks cycles with WARNING mode active.
- **User Action:** Request the door be serviced by a door maintenance technician. Door must be rebalanced and travel limits reset via the MEMORY RESET function. While waiting for the door to be serviced, use dead-man / constant-contact mode to open and close the door.

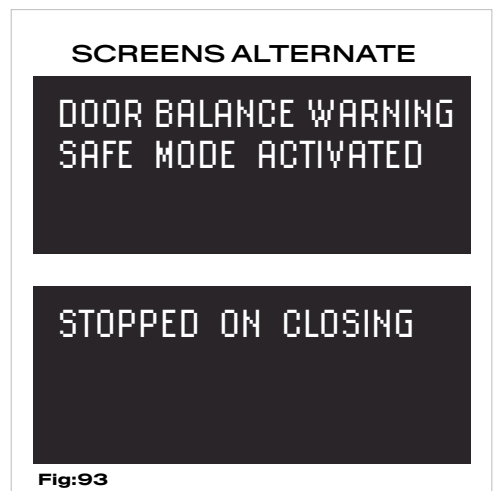

## DOOR BALANCE FAULT

Triggered when DAVE detects a serious abnormality. Door travel stops immediately. The user must press ■ to reboot the console, after which it restarts in dead-man / constant-contact mode. To resume normal operation, a door maintenance technician must service the door and reset the door travel limits.

- **Door Status:** Door Stops. Door enters WARNING mode.
- **LED Behaviour:** Console LED flashes.
- **Relay Output:** Alert Status relay is activated.
- **User Action:**
  - » Press ■ to reboot the console.
  - » Request a door maintenance technician to inspect and service the door and reset travel limits via the MEMORY RESET menu.
  - » Open and close the door in deadman / hold-to-operate mode until the door has been serviced

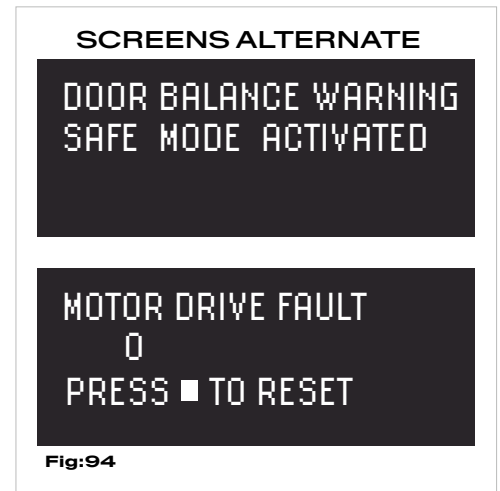



# Maintenance Requirements



## SAFETY WARNING

### Read Before Performing Maintenance

To ensure safe servicing of this operator, please follow these guidelines:

1. Disconnect power to the operator before starting any maintenance or inspection.
2. Perform a safety check of the entire system to identify any faults or hazards.
3. Ensure the door area is clear of people, vehicles, and any obstructions.
4. This product is not user-serviceable. Maintenance must only be carried out by trained and authorised technicians.

**Failure to follow these instructions may result in injury, equipment damage, or voiding of warranty.**



## AVERTISSEMENT DE SÉCURITÉ

### À lire avant d'effectuer la maintenance

Pour assurer un entretien sécuritaire de cet opérateur, veuillez suivre ces consignes :

1. Débranchez l'alimentation de l'opérateur avant de commencer toute opération de maintenance ou d'inspection.
2. Effectuez une vérification de sécurité de l'ensemble du système afin d'identifier tout défaut ou danger.
3. Assurez-vous que la zone de la porte est dégagée de toute personne, véhicule ou obstruction.
4. Ce produit n'est pas réparable par l'utilisateur. La maintenance doit uniquement être effectuée par des techniciens formés et autorisés.

**Le non-respect de ces instructions peut entraîner des blessures, des dommages à l'équipement ou l'annulation de la garantie.**

Item	Action Required	Monthly Check	Quarterly Check	Annual Check
Safety Devices	Check alignment Check operation	x		
Sprockets	Check tightness of set screws		x	
Drive Chain	Check sprocket alignment and chain tension Lubricate		x	
Coupler	Check alignment Check tightness of fasteners		x	
Fasteners	Locate all fasteners and check tightness.		x	
Manual Hauling	Check operation		x	
Power cord	Check for wear or damage		x	
Shafts	Check for wear or damage			x
Firmware	Update control software			x

## NOTES

**x:** Inspect item. Service or replace if/when deemed faulty

- Do not lubricate the motor or reducer.
- Motor bearings rated to specification.

# Troubleshooting Guide

ISSUE	POSSIBLE CAUSES	REMEDY
Nothing on LCD screen	Batteries not installed	Install fresh batteries with correct polarities
	Batteries inserted wrong way	Re-install batteries with correct polarities
	Low batteries	Install fresh batteries with correct polarities
	If console is wired, cable to drive unit & or console is loose, wired incorrectly or not connected	If wired to unit check wiring cable connection at console & drive unit main control board
	If console is powered by optional 5VDC power adaptor, power adaptor is not connected or not turned on at power source	Check & reconnect 5V power adaptor and reapply power
No yellow and green LED lit on operator cartridge	Missing power	Restore power to drive unit
	Wrong type cartridge used	Use correct cartridge
	Power inlet wiring issue	Restore power to drive unit
	Blown fuse	Change fuse
	Faulty power cord	Replace power cord
Awaiting connection but door works from buttons	No power to drive unit	Switch power on
	Console not paired to drive unit	Pair console to drive unit
	Interference	Use wired connection between console & drive unit
	Console is too far away from drive unit	Console need to be within 15 metres of drive unit
Bluetooth pairing successful but console buttons not functioning	RF buttons not paired	Go to Menu 5.6 and follow RF button pairing instructions
Hauling chain not working	Chain wheel not returning to its natural position	Check and free hand chain
	Disengagement harness faulty or not connected properly	Replace disengagement harness
Individual wired triggering devices (key switches push buttons etc) not functioning.	Wired device(s) fault creating fault at wired input.	Check OSC, OPN, CLS, GPA, GPB & OV connection & wiring. Check screen prompt for advice on which product is causing issue. Go to Menu 3 control & safety input status to identify issue.

ISSUE	POSSIBLE CAUSES	REMEDY
Stop (stop) active preventing unit operation	Link missing or loose from STP OV terminal on main control board	Insert link into STP & OV terminal
Tension active message on console	Wired cable tensioning (derailing) device into TEN & OV creating fault	Check screen prompt for advice on which device is causing issue. Go to Menu 3 control & safety input status to identify issue.
	Missing 10K resistor from OV TEN terminal on main control board	Insert 10K _0.25 watt resistor into OV and TEN terminal
	Missing wire link from OV STP terminal on main control board	Insert wire link between OV and STP terminal
Interlock active message on console	Dock level device wired to INT & OV creating fault	Check screen prompt for advice on which device is causing issue. Go to Menu 3 control & safety input status to identify issue.
	Missing 10K resistor from OV INT terminal on ACB06 PCBA	Insert 10K _0.25 watt resistor into OV and INT terminal
"ACTIVATE KEY TO ENTER MENU" message on console	Key switch on console is in lock position	Turn keyswitch anticlockwise
	Lost key	Contact supplier for new key
	Faulty key switch harness or not plugged properly	Replace harness
Limits not setting	Positioning encoder or harness faulty	Replace limit assembly
Operator makes noise but door not moving	Door is too heavy to lift	Check door weight is within operator capability specification and in good working order
	Key from drive shaft missing	Insert key in the key way and tighten two grub screws
Slow stop is too quick	Slow rate not adjusted correctly	Edit / adjust slow rate - higher the value quicker the door will stop
Unit will open but not close	Safety device held active SD1 SD2 SD3	Check screen prompt for advice on which device is causing issue. Go to Menu 3 control & safety input status to identify issue. Check alignment, batteries wiring of safety devices

ISSUE	POSSIBLE CAUSES	REMEDY
POSITION SENSOR FAULT XXXX*	Issue with the positioning encoder sensor.	Reset fault and try to operate again. If problem persists replace the positioning encoder.
POSITION SENSOR FAULT 7A00	Loss of communication with the position encoder.	Reset fault and try to operate again. If problem persists, check wiring to positioning encoder. If wiring is in good order, then replace positioning encoder. If problem persists, replace main control board.
DIRECTION FAULT XXXX	Operator has detected that the door has traveled in the wrong direction.	Reset fault and try to operate again.
MOTOR DRIVE FAULT 1	Over current fault - Likely caused by excessive motor load.	Reset fault and try to operate again. If problem persists then check door condition including balance.
MOTOR DRIVE FAULT 21	Over-current or over-temperature fault	
MOTOR DRIVE FAULT 61	Over-current or over-temperature fault	
MOTOR DRIVE FAULT XXXX	Result of a combination of more than one of the above codes	Reset fault and try to operate again.
POSITION WRAP ERROR XXXX	Caused by door moving outside of expected range of movement.	Attempt to move door back in into normal operating range using manual chain and then reset fault.
CLOSE SET ERROR	Profiling cycle after limit setting has been interrupted by a safety or control input.	Acknowledge error by pressing SET and then repeat limits setup.
OPEN SET ERROR		
MOTOR COMMS ERROR FFFF	Loss of communications between main control board and motor controller.	Reset Fault and try to operate again. If the fault only occurs when the door is closing only, then rebalance the door. If fault is reported continuously then replace main control board.

\* X can represent any numeral

**If any listed action doesn't resolve or any other fault code presents, contact Tech Support**

## SUPPORT

---

For assistance with this product, please contact Automatic Technology using the regional phone numbers and websites listed below, or by emailing [support@automatictechnology.com](mailto:support@automatictechnology.com).

You can also visit DAVE's product page for the latest version of the manual and other technical documentation: [www.automatictechnology.com/dave](http://www.automatictechnology.com/dave)

---

## PRODUCT WARRANTY

---

For full warranty terms and conditions relating to DAVE products, please visit: [www.automatictechnology.com/warranty](http://www.automatictechnology.com/warranty)



## CONTACT

---

### AUSTRALIA

**W:** <https://www.automatictechnology.com/au>

**P:** **1300 133 944**

---

### NEW ZEALAND

**W:** <https://www.automatictechnology.com/nz>

**P:** **0800 673 637**

---

### NORTH AMERICA

**W:** <https://www.automatictechnology.com>

**P:** **1-800-934-9892**

---