



Controll-A-Door® P

Controll-A-Door® P

Sectional Door Opener

Instruction Manual

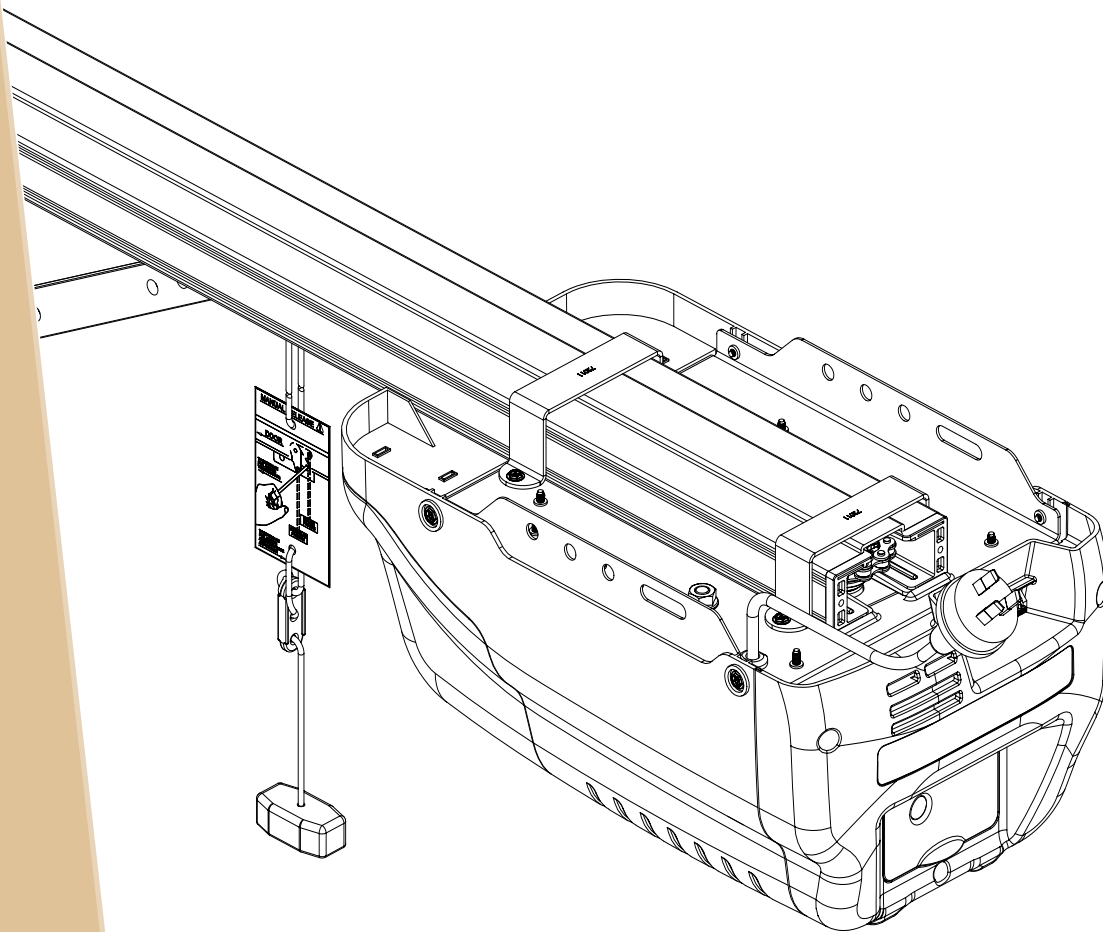

N1854

B&D Doors is a division of B&D Australia Pty Ltd
ABN 25 010 473 971



®

Controll-A-Door® P

Sectional Door Opener

Safety Rules	03	How To Use Your Opener	24
Default Settings and Specifications	04	Transmitter	24
About Your B&D Opener	05	Locking	24
Operating Controls	06	Manual Door Operation	25
Kit Contents	08	Power Failure	25
Installation	09	Transmitter battery	25
Knockdown C-Rail Assembly	09	Safety Infra-red Beam	25
Attaching the C-Rail	10	Auto-Close	25
Determine Door Type	11	Courtesy Light	25
Mounting - Track Type Door	12	Auxiliary Output	25
Mounting - Non-Track Type Door	13	Vacation Mode	25
Mounting Door Bracket & Arms	14	Pet (Pedestrian) Mode	25
Programming the Opener	15	Troubleshooting Guide	26
Setting Travel Limits	15	Parameters	27
Safety Obstruction Force Test	17	Maintenance	28
Adjusting Safety Obstruction Force	18	Spare Parts	29
Coding Transmitters	19	Warranty	31
Door	19		
Courtesy Light	19		
Vacation Mode	20		
Auxiliary Output	20		
Pet Mode	21		
Erasing Transmitter Codes	21		
Mounting Wall Transmitter	21		
Accessories	22		
Terminal Block	22		
Remote Aerial	22		
Safety Infra-red Beam	23		
Electric Key Switch	23		



Safety Rules

Please read these important safety rules



These safety alert symbols indicate a personal safety or property damage instruction exists. **READ THESE INSTRUCTIONS CAREFULLY.**



This automatic garage door opener is designed and tested to offer safe service provided it is installed and operated in strict accordance with the following safety rules. Failure to comply with the following instructions may result in death, serious personal injury or property damage.

-  **CAUTION:** If your garage has no pedestrian entrance door, an emergency access device should be installed. This accessory allows manual operation of the garage door from outside in case of power failure.
-  Position the Garage Door Opener so that the power plug is accessible when inserted into the power outlet (EN 60335-1).
-  This opener should be installed in accordance with relevant Australian Standards.
-  Do not allow children to play with door controls.
-  Keep transmitters away from children.
-  Watch the moving door and keep people away until the door is completely opened or closed.
-  Activate the opener only when the garage door is in full view, free of obstructions and with the opener properly adjusted.
-  Keep the garage door balanced. Sticking or binding doors must be repaired. Garage doors, door springs, brackets and their hardware are under extreme tension and can cause serious personal injury. Do not attempt any garage door adjustment. Do not use if repair or adjustment is needed. Call for professional garage door service.
-  Install the optional wall transmitter in a location where the garage door is visible, but out of the reach of children at a height of at least 1.5m from the floor.
-  Disconnect electric power to the garage door opener before removing covers.
-  Doors requiring over 400N of force to move must have Safety Infra-red Beams fitted.
-  Do not wear rings, watches or loose clothing while installing or servicing a garage door opener.
-  This opener is not suitable for commercial, industrial or common entry applications.
-  To avoid serious personal injury from entanglement, remove all unnecessary ropes or chains and disable any equipment such as **locks** which are not needed for powered operation.
-  Installation and wiring must be in compliance with your local building and electrical codes. Connect the power cord only to properly earthed mains. If an extension lead must be used, make sure it is a 3-core lead and approved to 7 amp capacity.
-  If the power cord is damaged, it must be replaced by the manufacturer, its service agent or a similarly qualified person in order to avoid a hazard.
-  When using optional Auto-Close mode, a Safety Infra-red Beam (Part No 062734) must be fitted correctly and tested at regular intervals. Extreme caution is recommended when using Auto-Close mode. All safety rules must be followed.
-  This opener is a plug in domestic appliance and is designed for indoor use only. It must be installed in a dry position that is protected from the weather.
-  The opener is not intended for use by young children or infirm persons without supervision.



WARNING! It is vital for the safety of persons to follow all instructions. Save these instructions.

B&D Doors to the extent that such may be lawfully excluded hereby expressly disclaims all conditions or warranties, statutory or otherwise which may be implied by laws as conditions or warranties of purchase of a B&D Garage Door Opener. B&D Doors hereby further expressly excludes all or any liability for any injury, damage, cost, expense or claim whatsoever suffered by any person as a result whether directly or indirectly from failure to install the B&D Garage Door Opener in accordance with these installation instructions.

Default Settings & Specifications

Factory default settings

	Default	Step	Minimum	Maximum
Maximum motor run time	40 seconds	-	-	-
Courtesy light time	4 minutes (approx.)	-	-	-
Obstruction force margin	2	1	0	24
Auto-Close time	30 seconds	-	-	-

Technical specifications

Power supply	230V - 240Va.c. 50Hz	
Transformer rating	24Va.c.	
Standby power	2.0 Watts	
Motor power	250 Watts (1/3 HP)	
Motor type	Alternating Current	
Maximum door opening:	Width: Height: Area Weight:	5500mm 3000mm 16.5m ² 100kg
Minimum headroom	50mm	
Short term peak force	800N (80kg)	
Lift force	600N (60kg)	
Nominal force	150N (15kg)	
Receiver type	UHF Multi-frequency FM Receiver	
Receiver code storage capacity	14 X 4 button Transmitter Modes	
Transmitter frequency	UHF Multi-frequency FM Transmitter	
Coding type	Code hopping	
Number of code combinations	Over 4.29 billion random codes	
Code generation	Non-linear encryption algorithm	
Transmitter battery	CR2032 (3 Volts)	
Courtesy light	LED (Light Emitting Diodes)	
Controller fuse	5A slow blow	
Rated temperature	+5° to 40°	

Note: Intermittent operations may occur in areas which experience very strong winds. The strong wind puts extra pressure on the door and tracks which may in turn intermittently trigger the safety obstruction detection system.



About Your B&D Opener

Thank you for choosing a **Controll-A-Door® P** automatic garage door opener, designed and developed in Australia by B&D Doors & Openers.

The technically advanced construction of this B&D opener ensures you enjoy the following benefits:

Warranty

Five (5) year/10,000 cycles full parts and labour warranty on motor, electronics and mechanical components of the opener when installed by an Approved B&D Dealer (conditions such as annual garage door servicing apply).

Tri-Tran Frequency Hopping Technology

Every time a transmitter is used, it simultaneously sends a signal over three different frequencies, reducing the chance of interference from other radio frequency sources.

Code Hopping Technology

Every time a transmitter is used a new security code is generated from over 4.29 billion possible combinations. This greatly enhances the security of the system and makes "code grabbing" a thing of the past!

Multi-Channel Transmitter

Multi-channel transmitters allow you to operate other devices such as an adjoining garage door or automated gate from the same handy unit.

Warranty Expired Indicator

The opener will indicate that the number of cycles covered by the warranty has been reached by flashing the courtesy light 10 times after each operation. This flashing will continue for 20 cycles unless it is reset by pressing the LIMIT SET button while the courtesy light is flashing.

Safety Reversing System

The automatic safety reverse system significantly reduces the risk of death or serious injury if trapped by a closing door. The safety reverse force can be adjusted for environmental conditions such as windy areas.

LED Courtesy Light

Using the latest Light Emitting Diode (LED) technology, the opener features two light modules consisting of three LEDs each. These modules produce a brilliant white light that illuminates the garage upon activation.

The courtesy light automatically switches on for approximately four (4) minutes (time programmable) when operating the door. This can also be programmed to turn on and off from a transmitter.

Memory Retention

In case of a power failure the opener does not lose the transmitter codes or limit settings.

Manual Release

The manual release handle allows the door to be operated by hand in the event of a power failure. Handle needs to be a minimum of 1.8m from floor.

Self Locking

There is no need to manually lock your garage door, as the opener 'positively' locks the door when closed.

Periodic Maintenance Indicator

The SERVICE LED will illuminate to indicate that periodic maintenance is required. Contact your dealer/installer for service.

Service Fault Indicator

Flashing LEDs on the control panel easily identify operational problems or service requirements.

Dynamic Door Profiling

Changing door characteristics are automatically compensated for and "learnt" with every operation of the door.

Auto-Close

The Auto-Close option can be programmed to shut the door approximately 30 seconds after it opens. PLEASE NOTE - Safety Infra-red Beams must be installed for this option to function.

External Aerial

An external aerial can be connected for sites where radio reception is poor.

Vacation Mode

A transmitter can be programmed to disable the garage door opener's radio receiver. This is ideal if the door is to be left idle for prolonged periods.

Pet (Pedestrian) Mode

A transmitter can be programmed to open the door partially to allow pets access to the garage. The door opening height is adjustable via a handheld programmer.

Auxiliary Output

You can program a spare button on your transmitter to operate this output, which can control items that use a momentary close switching mechanism.

Anti-Travel Electronic Brakes

The opener features an electronic anti-travel brake mechanism to ensure the opener stops the door exactly at the set limit positions.

Operating Controls

- 01. PROG INPUT** is used to connect the Universal Handheld Programmer to edit control and receiver functions.
- 02. Safety Infra-red Beam Auto-Close Shunt** has to be placed on to enable the Auto-Close feature.
- 03. Terminal Block:**
 - PWR** is used to power devices such as Safety Infra-red Beams and external receiver (100 milliamp max).
 - IR** input is used to connect to Safety Infra-red Beam.
 - IR(OV)** is a 0 volt connection for Safety Infra-red Beam.
 - COM** is a common -ve ground for accessories.
 - OSC** is used for the connection of a wired switch (momentary contact). This switch can then be used to open, stop or close the door. Install the wall switch in a location where the switch is out of reach of children and the garage door is visible.
 - AUX** allows the opener to operate other devices such as external lights, or an alarm system.
- 04. OPEN LIMIT LED (Green)** is used during installation to help set the open limit position. It also illuminates and flashes as the door opens, and remains on when the open limit position has been reached.
- 05. CLOSE LIMIT LED (Red)** is used during installation to help set the close limit position. It also illuminates and flashes as the door closes, and remains on when the close limit position has been reached.
- 06. DATUM ADJUST SCREW** is used during installation to set mid point of the door's travel.
- 07. MINUS (-) button (Red)** is used during installation to set the close limit position. Pressing and holding this button will move the door in the close direction. Movement stops when the button is released. This button is also used for storing or erasing the transmitter button you wish to use to command the door to open, stop or close.
NOTE: The safety obstruction system is inoperable whenever the MINUS (-) button is used to move the door.
- 08. CODE SET LED (Red)** flashes when a transmitter button is stored.
- 09. LIMIT SET button (White)** is used during installation, together with the PLUS (+) and MINUS (-) buttons, to set the door limit positions. The LIMIT SET button is also used to re-initialise the opener.
- 10. SERVICE LED (Yellow)** indicates when the opener requires service or repairs, and is used in conjunction with the datum screw during installation.
- 11. OPERATE button (Blue)** is used during installation to test the open, stop and close cycles for the opener. The opener has to be initialised by the LIMIT SET button to make the OPERATE button operable.
- 12. FORCE MARGIN SET button.** The obstruction force margin is set automatically during installation. The margin can be adjusted manually using the FORCE MARGIN SET button (White). Holding the FORCE MARGIN SET button and pressing PLUS (+) or MINUS (-) buttons will increase or decrease the amount of force. The FORCE MARGIN SET button should only be used if environmental factors, such as high winds, affect the door's operation.
- 13. PLUS (+) button (Green)** is used during installation to help set the open limit position. Pressing and holding this button will move the door in the open direction. Movement stops when the button is released.
NOTE: The safety obstruction system is inoperable whenever the PLUS (+) button is used to move the door.



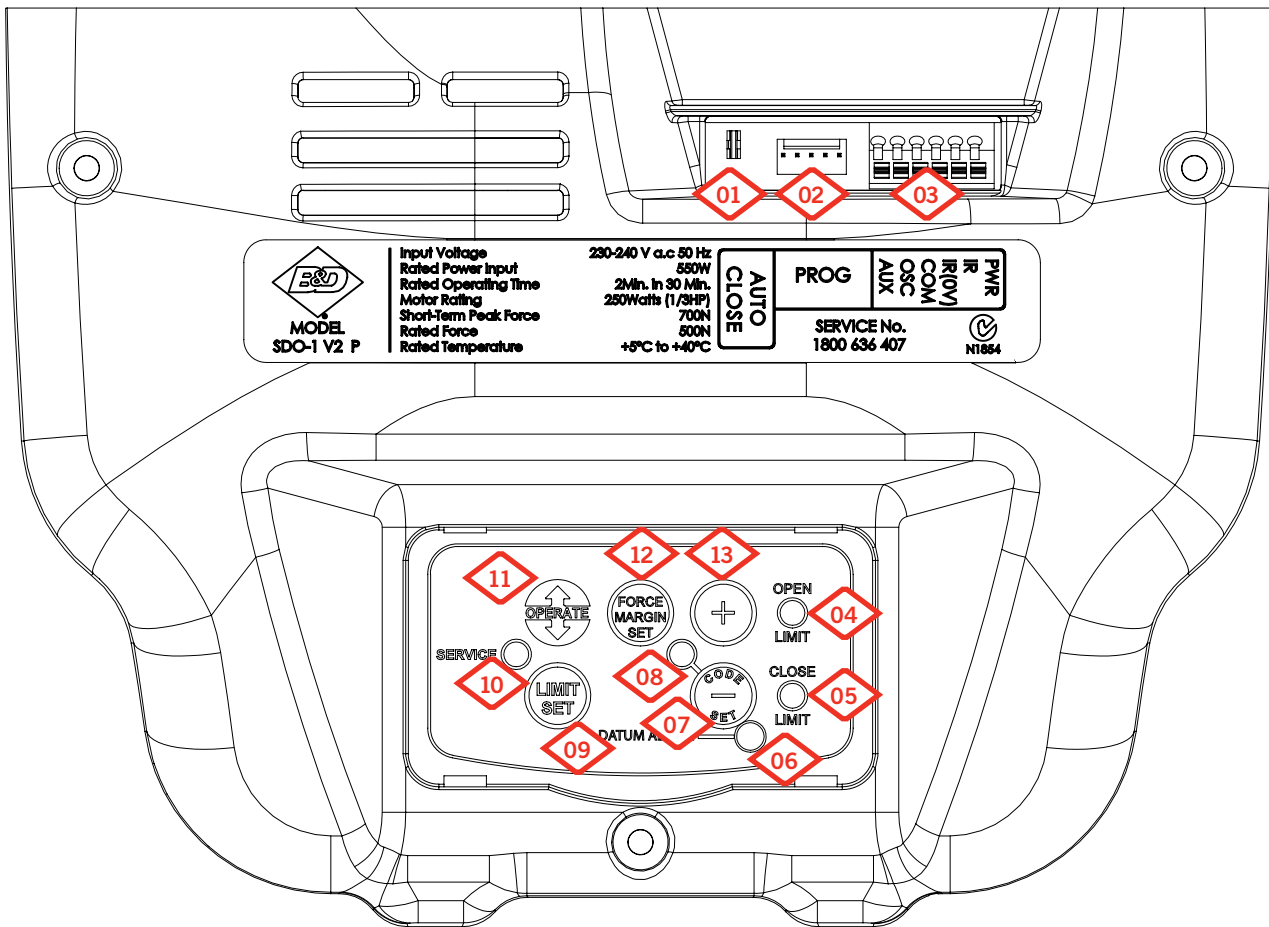

Fig. 01

Kit Contents

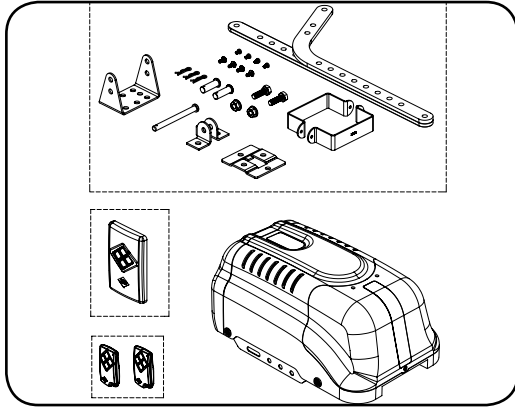

Fig. 02

Powerhead Unit

- 1 x Controll-A-Door® P powerhead (Fig. 02)
- 1 x Transmitter pack (Fig. 02)
(Pack includes two keyring transmitters and batteries)
- 1 x Wall mount transmitter with battery
- 2 x Door attachment arms (Fig. 02)
- 1 x Accessory and hardware pack (Fig. 02)
- 1 x Installation Manual
- 1 x Chain Clips

PLUS

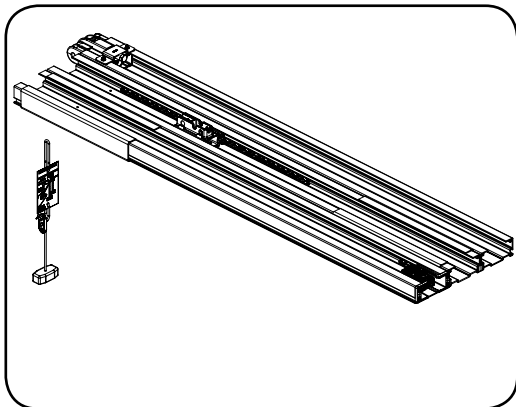

Fig. 03

Multi Piece Knockdown Track With Pre-Assembled Chain

IMPORTANT NOTE: If a modification to the length of the track is required, the adjustment must be made from the powerhead end only.

OR

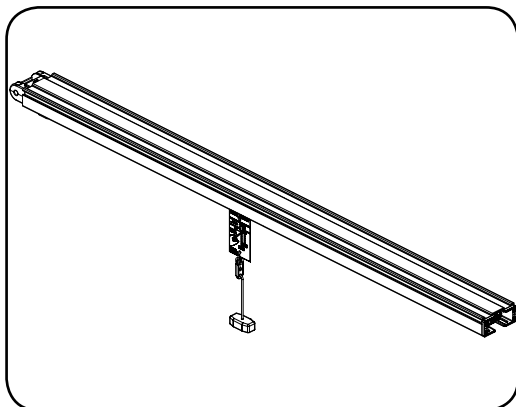

Fig. 04

Single Piece Track With Pre-Assembled Chain

NOTE: Chain in one piece rail has been tensioned by the factory. Adjust the tension of the chain to suit.

IMPORTANT NOTE: If a modification to the length of the track is required, the adjustment must be made from the powerhead end only.

Attaching the C-Rail

Fig. 06

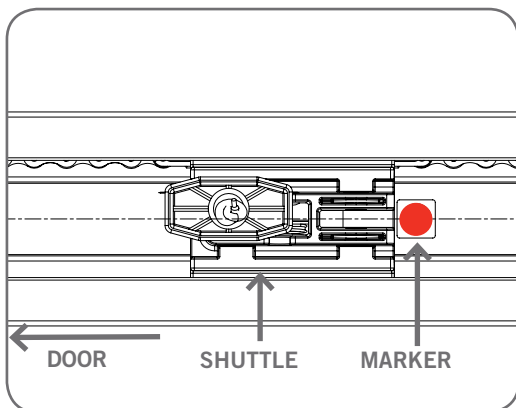

IMPORTANT NOTE: Do not power up the powerhead before assembling to the C-Rail.

Step 1 - Centre the Shuttle

Make sure the shuttle is near the MARKER, which is located in the centre of C-Rail (**Fig. 06**).

Fig. 07

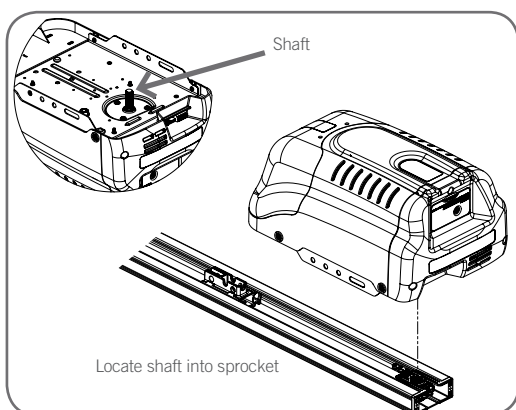

Step 2 - Connect the Powerhead to the C-Rail

Locate and insert the powerhead's shaft into the C-Rail's sprocket as shown in (**Fig. 07**).

Fig. 08

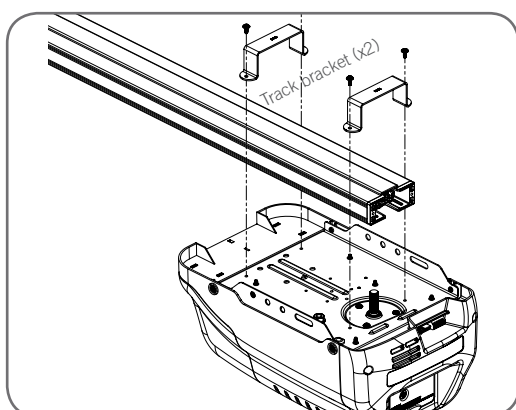

Step 3 - Secure the C-Rail

Fix the two track brackets as shown in (**Fig. 08**). Fix with the four screws supplied in accessory pack.

Determine the Door Type

IMPORTANT NOTE: Ensure that no parts of the door extend over public footpaths or roads before installing the opener.

Step 4 - Determine Door Type

Determine which type of garage door you have as illustrated in (Fig. 09) to (Fig. 11).

For a sectional (panel) door on tracks **(Fig.09)** proceed with the installation from Step 5.

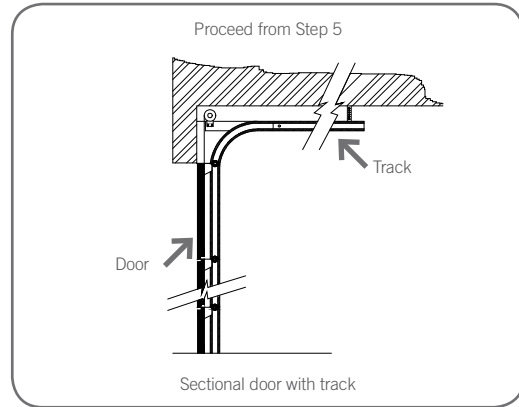

Fig. 09

For a one piece door on tracks **(Fig.10)** proceed with the installation from Step 5.

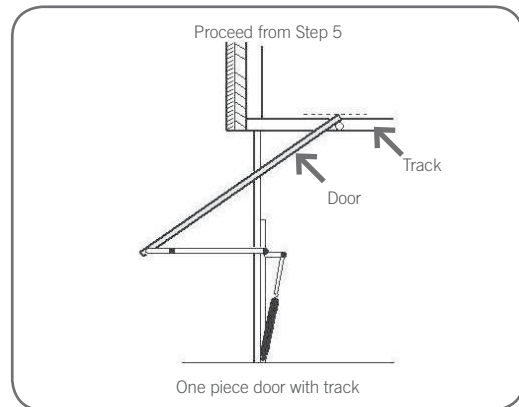

Fig. 10

For a one piece door without tracks (on springs) **(Fig.11)** proceed with the installation from Step 9.

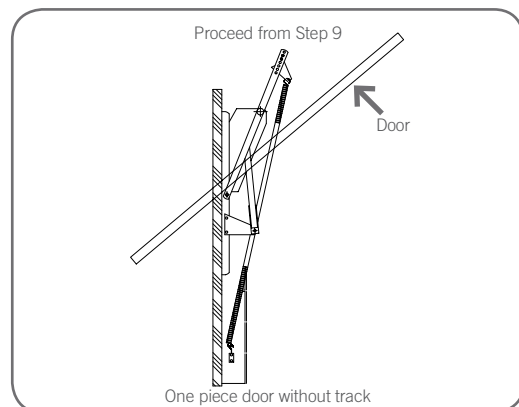

Fig. 11

Mounting on a Track Type Door

Fig. 12

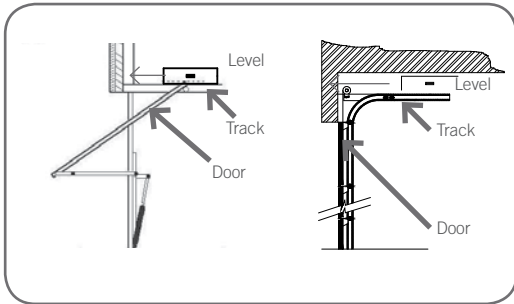

Fig. 13

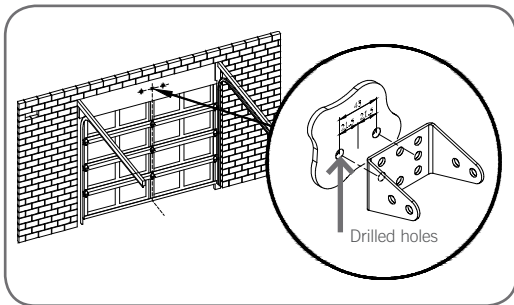

Fig. 14

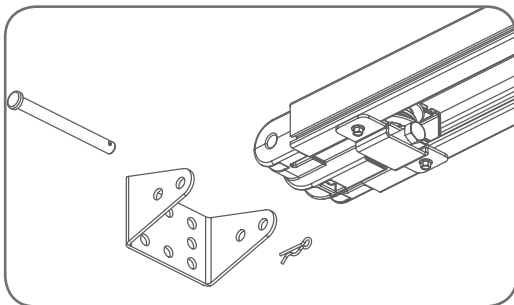
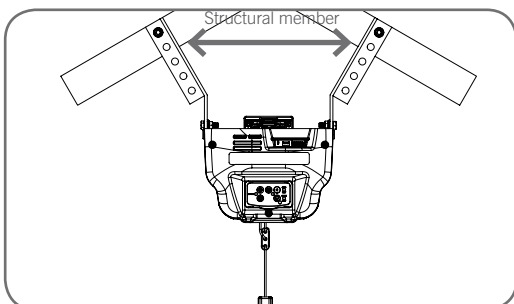

Fig. 15



Step 5 - Determine Bracket Position

- Open the door and find the highest point of travel of the top door panel.
- Using a level, transfer this height to the wall above the door (Fig. 12) and mark a line 60mm above it.
- Determine the centre point on the wall above the door. Then draw two (2) lines extending 21.5mm from each side of the centre point. (Fig. 13)

Step 6 - Mounting the Wall Bracket

- Centre the bracket over the intersection of these two lines. Mark centres for at least two holes (Fig. 13).
 - Ensure a solid mounting point is behind these holes.
- Drill holes into the wall with an appropriate sized bit.
- Secure bracket to the wall using:
 - IF CONCRETE OR BRICK - 10mm dynabolts.
 - IF TIMBER - wood screw #20 or equivalent (minimum 50mm long).



WARNING: Make sure concrete, brick wall or timber lintels are solid and sound so as to form a secure mounting platform.

Step 7 - Attach the C-Rail to the Wall Bracket

- Attach the C-Rail assembly to the wall bracket with the 90mm long clevis pin and secure with the supplied snap pin (Fig. 14).
- Leave the powerhead in its packing box for protection during installation.

Step 8 - Securing the Powerhead to the Ceiling

- Raise the powerhead from the packing box and support it in the horizontal position with a step ladder or support system above the door.
- Open the garage door. Rest the opener on the open door and use a scrap piece of wood to bring it to horizontal level.
- Line up the track perpendicular to the wall.
- Secure the perforated angle (not supplied) to the ceiling above where powerhead's mounting holes will be once fully installed. A representative mounting is shown (Fig. 15).
- Connect the powerhead to the ceiling mounted perforated angle with M8x20mm screws and nuts. Strips should not extend more than 18mm below centre of powerhead mounting holes (Fig. 15).

For an alternative mounting option, go to Step 12.1



WARNING: The opener must be securely fastened to structural supports, otherwise opener failure may ensue causing serious personal injury and/or property damage.

Mounting on a Non-Track Type Door

WARNING: Make sure concrete, brick wall or timber lintels are solid and sound so as to form a secure mounting platform.

Step 9 - Determine the Door's Centre

- Find the centre of the door and mark this location both above the door and on top of the door.
- Draw two lines 21.5mm either side of this (Fig. 16).

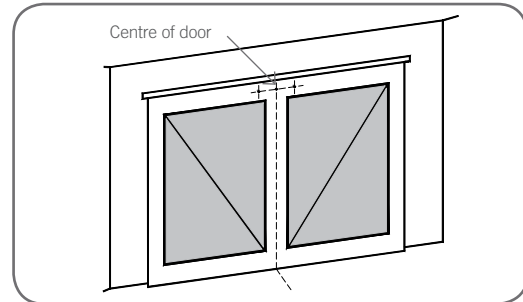

Fig. 16

Step 10 - Prepositioning the Opener

- Raise the door to open position.
- Rest the opener on the top edge of the door with end of the C-Rail against the wall (Fig. 17).
- Support the powerhead level with the lowest point of the open door (Fig. 17).

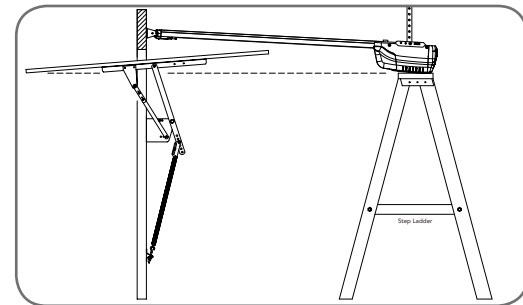

Fig. 17

NOTE: Do not slide C-Rail along the face of the door.

Step 11 - Mounting the C-Rail

- Close the door slowly. The C-Rail will be elevated by the top edge of the door as it moves.
- Stop the door when it is at its highest point of travel. Allow 25mm additional height for clearance between the door and the track (Fig. 18).
- Support the C-Rail in this position and close the door.
- The height determined in Step 11(b) will be the height at which to mount the wall bracket.
- Centre the bracket along the line determined in Step 9.
- Using the bracket as a template, mark a minimum of two holes and drill with appropriate size bit. For a more secure fitting, the wall bracket can be anchored using more than two holes.
- Secure the bracket to the wall using:
IF CONCRETE OR BRICK - 10mm dynabolts.
IF TIMBER - wood screw #20 or equivalent (minimum 50mm long).
- Attach the wall bracket to the C-Rail with the 90mm long clevis pin (Fig. 19) and secure by a snap pin.

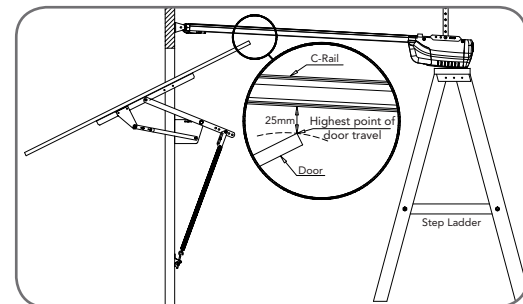

Fig. 18

Step 12 - Securing the Powerhead to the Ceiling

- Secure the perforated angle (not supplied) to the ceiling above where powerhead's mounting holes will be. See (Fig.15) for a representative mounting.
- Connect the powerhead to the ceiling mounted perforated angle with M8x20mm screws and nuts. Strips should not extend more than 18mm below centre of powerhead mounting holes (Fig. 15).

WARNING: The opener must be securely fastened to structural supports, otherwise opener failure may ensue causing serious personal injury and/or property damage.

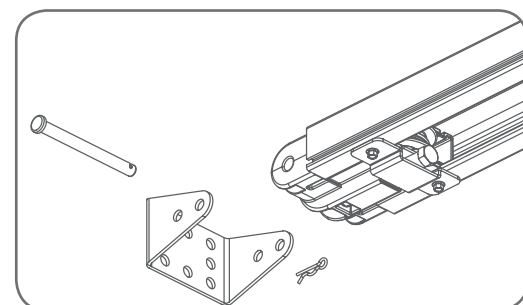
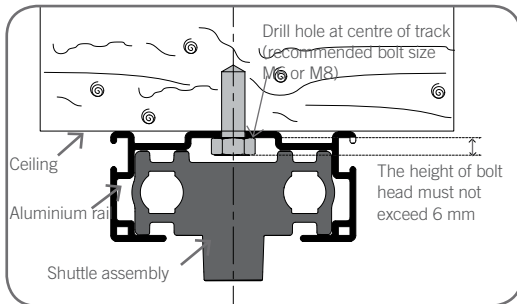

Fig. 19

Mounting Door Bracket and Arms

Fig. 20



Step 12.1 - Alternative Mounting Option

The opener can be fastened to the roof by driving a bolt through the C-Rail into a structural timber support. The bolt head's height must not exceed 6mm (Fig. 20).

Fig. 21

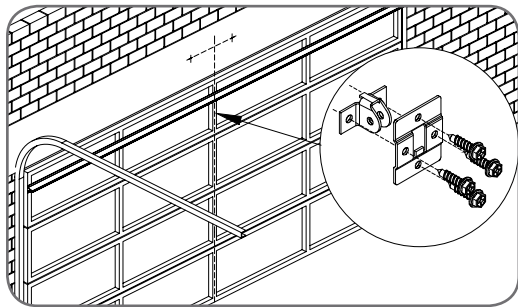

Step 13 - Mounting Door Bracket

The door bracket comes in two parts. The bottom plate with two mounting holes is used on its own for one piece doors. For sectional doors, the top plate is placed over the bottom plate and is fixed with four (4) screws (Fig. 21).

- Mount the door bracket, or bracket assembly, on the door's centre line one-third down the top panel (Fig. 21) using M6 or equivalent screws (not supplied),



NOTE: If in doubt about the door's strength, reinforcement may be added to the door's frame where necessary. Door damage may occur if the bracket is installed on a panel with insufficient strength. The opener's warranty does not cover damage caused to the door and/or door panels.

Fig. 22

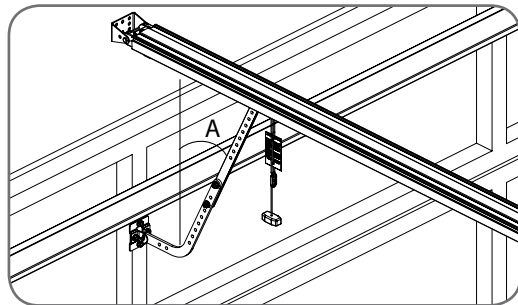

Step 14 - Attaching the Arms

FOR SECTIONAL AND ONE PIECE DOORS WITH TRACK:

- Assemble the bent and straight arms with bolts and nuts supplied in the accessory pack (Fig. 22). Always use both bent and straight arms.
- Connect the assembled arm to the bracket and the disengaged trolley with clevis and snap pins. The angle "A" must be more than 10° (Fig. 22).



WARNING: Connecting the bent arm other way around may damage the door.

Fig. 23

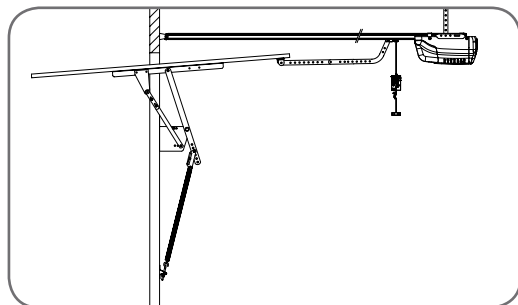

FOR ONE PIECE DOORS WITHOUT TRACK

- Assemble the bent and straight arms as shown in (Fig. 23) with bolts and nuts supplied in the accessory pack. Always use both the bent and straight arms.
- Connect the assembled arm to the bracket and the disengaged trolley with clevis and snap pins.
- If installing on a door with a bad wave action, lengthening the arm will assist in reducing this effect.

Setting Travel Limits

NOTE: The OPERATE button will not function until the open and close limit positions are set.

NOTE: If a Safety Infra-red Beam is to be used it must be installed before setting the travel limits.

Step 15.1 - Set the Datum Position

- Remove the controls cover to access the control panel.
- Move the door manually to engage the shuttle assembly onto the chain index.

IMPORTANT NOTE - If the manual release handle is more than 1.8 metres from floor level when the opener is installed, extend the handle to a height less than 1.8 metres.

- Plug the power cord into a mains power point and switch the power on. The CLOSE LIMIT LED should be flashing.
- Press and hold the MINUS (-) or PLUS (+) button to move the door to the halfway open position. (Fig. 25).

WARNING: The safety obstruction detection system is inoperable while MINUS (-) and PLUS (+) drive buttons are being used and travel limits are not set.

- Using a small blade screwdriver, turn the DATUM ADJUST screw until the yellow SERVICE light comes on (Fig. 26).
 - » If the SERVICE light is already illuminated when the door is halfway up, turn the DATUM ADJUST screw until the light goes off, then turn back one notch to illuminate again.

Step 15.2 - Set the Close Limit Position

- Press and hold the MINUS (-) button until the door reaches the desired close limit position. Single presses of the button will inch the door closed (Fig. 27).
- Press the LIMIT SET button to store the close position into memory (Fig. 27).

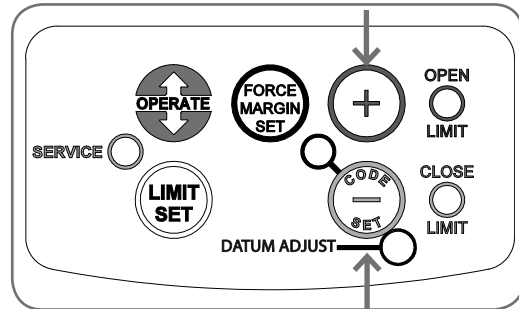

Fig. 24

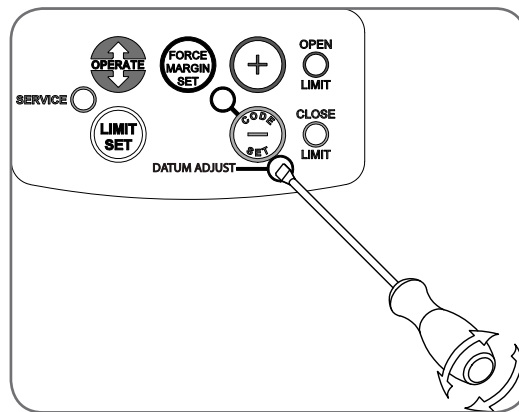

Fig. 25

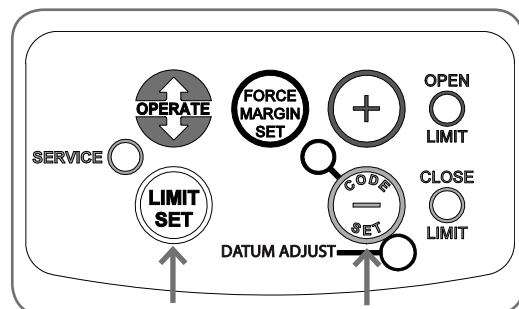

Fig. 26

Set Screw

Set the door to the closed position first



Setting Travel Limits

Fig. 27

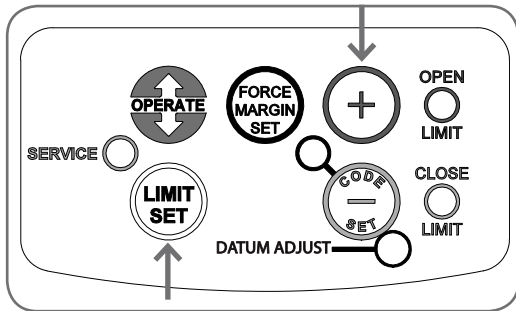

Step 15.3 - Set the Open Limit Position

- Press and hold the PLUS (+) button until the door reaches the desired open limit position. Single presses of the button will inch the door closed (Fig. 27).



IMPORTANT WARNING: The door will automatically close, open and close again once Step 15.3(b) is performed. Ensure that no persons or objects are in the door's path.

- Press the LIMIT SET button to store the close position into memory (Fig. 27).
- The door will now automatically close and open to the safety obstruction settings profile. Please be aware of the above warning.

The opener can now be operated with the OPERATE button.

Step 15.4 - Resetting the Door Limit Positions

The door limit positions can be deleted for new positions using the steps below.

- Press and hold the CLOSE button for six (6) seconds until you hear three beeps and the CLOSE LIMIT LED starts to flash.
- Release the CLOSE button.
- Follow Steps 15.1 to 15.3 to set new travel limit positions.

Safety Obstruction Force Test

! Please take care when testing the Safety Obstruction Force. Excessive force may cause **SERIOUS PERSONAL INJURY** and/or **PROPERTY DAMAGE** can result from failure to follow this warning.

Step 16.1 - Testing Close Cycle

- Press the OPERATE button to open the door (Fig. 28).
- Place a piece of timber approximately 40mm high on the floor directly under the door (Fig. 29).
- Press the OPERATE button to close door. The door should strike the object and start to re-open.

Step 16.2 - Testing Open Cycle

- Press the OPERATE button to close the door (Fig. 28).
- Press again to open the door. When the door reaches the half open point, grab the bottom rail of the door firmly and the door should stop.
- If the door does not reverse readily when closing, or stop when opening, the force may be excessive and need adjusting, refer to STEP 16.4 on page 18.

! **IMPORTANT WARNING:** If the door is closing and is unable to re-open when obstructed, discontinue use. Do not use a door with faulty obstruction sensing. Repair fault and re-test before using.

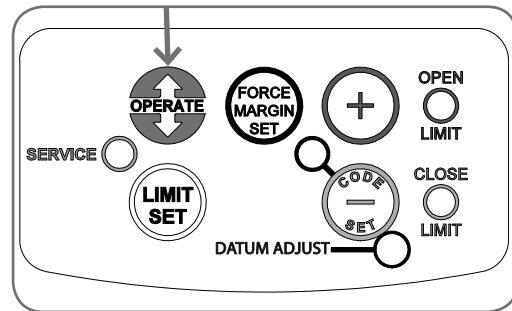

Fig. 28

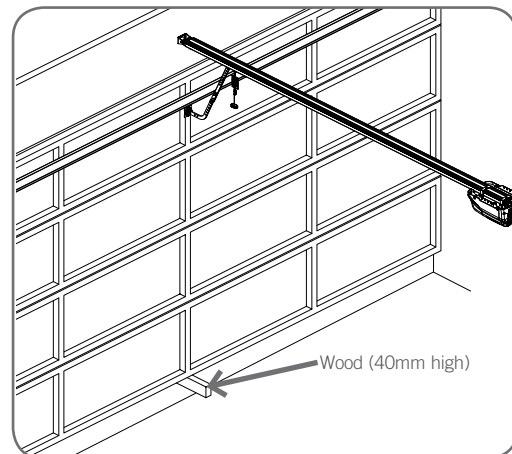

Fig. 29

Adjusting Safety Obstruction Force

Fig. 30

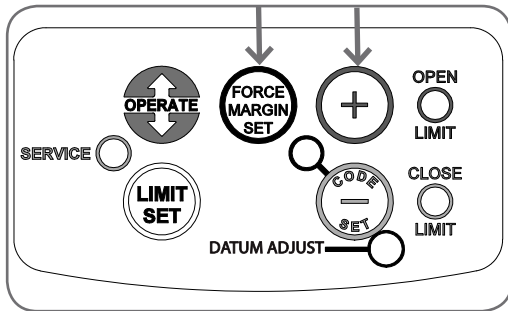

Fig. 31

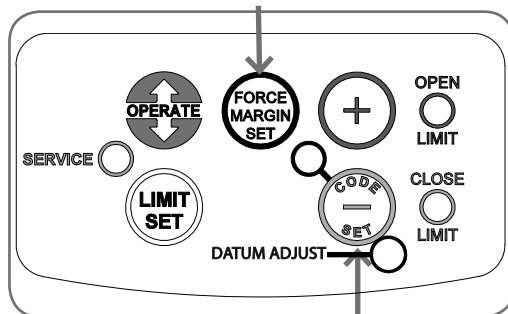
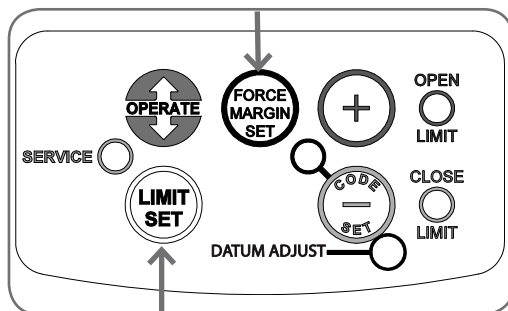

Fig. 32



Adjusting Safety Obstruction Force

The Safety Obstruction Force is calculated automatically and set in the memory on the opener during setup. It is usually not necessary to adjust the Safety Obstruction Force. The only time the force may need to be increased is due to environmental conditions, for example, windy or dusty areas, and areas with extreme temperature changes.



WARNING: Doors requiring over 400N of force to move must have Safety Infra-red Beams fitted for safety.

Step 16.3 - To Increase Force Pressure

- Press and hold the FORCE MARGIN SET button (Fig. 30).
- While holding down the FORCE MARGIN SET button, press the PLUS (+) button. Each press increases the force margin.
- The OPEN LIMIT LED will flash each time the PLUS (+) button is pressed to indicate an increase in force.
 - If the OPEN LIMIT LED flashes continuously when the PLUS (+) button is being pressed, this indicates that the maximum force pressure setting has been reached.
- Test the force again as per Steps 16.1 and 16.2 on page 17.

Step 16.4 - To Decrease Force Pressure

- Press and hold the FORCE MARGIN SET button (Fig. 31).
- While holding down the FORCE MARGIN SET button, press the MINUS (-) button. Each press decreases the force margin (Fig. 31).
- The CLOSE LIMIT LED will flash each time the MINUS (-) button is pressed to indicate a decrease in force.
 - If the CLOSE LIMIT LED flashes continuously when the MINUS (-) button is being pressed, this indicates that the minimum force pressure setting has been reached.
- Test the force again as per Steps 16.1 and 16.2 on page 17.

Step 16.5 - To Recall Factory Set Force

- While holding down the FORCE MARGIN SET button, press the LIMIT SET button (Fig. 32) for two (2) seconds.
- Release both buttons. The default setting should now be recalled.

Coding Transmitters

Step 17.1 - Storing the Transmitter Code

The opener can only operate from transmitters that have been programmed into its receiver. The receiver needs to learn the codes of any transmitter that will be used with the operator. Up to fourteen (14) codes can be stored in the receiver's memory.

- Ensure that the battery is inserted into the transmitter.
- Press the CODE SET button and release. The CODE SET LED will illuminate to indicate the opener is in Code Learn mode. If a valid code is not stored within 15 seconds the opener will exit Code Learn (**Fig. 33**).
- Press the transmitter button (one of four) that you want to control the door. The CODE SET LED will begin to flash.
- Press the same transmitter button again. The CODE SET LED will illuminate for one second and then go out.
- The transmitter is now coded to operate the door - press the button to test.

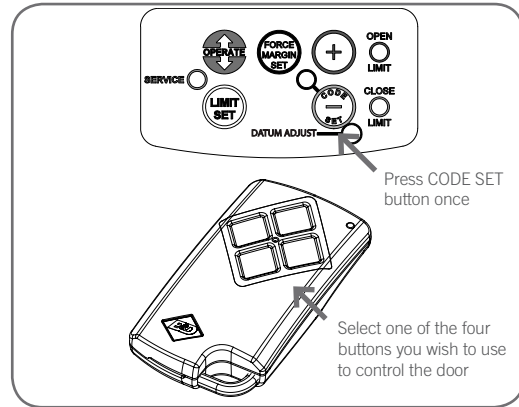

Fig. 33

Step 17.2 - Setting the Transmitter to Operate the Courtesy Light

Although the courtesy light comes on with each operation of the opener, it may also be controlled by a transmitter without operating the door.

- Press the CODE SET button twice. The CODE SET LED will illuminate and the courtesy light will turn on to indicate that the light code learning is active (**Fig. 34**).
- Choose a transmitter button not already coded into the receiver. Press this button and the CODE SET LED will begin to flash.
- Press the same transmitter button again. The CODE SET LED will illuminate for one second and then go out.
- The transmitter is now coded to operate the light - press the button to test.

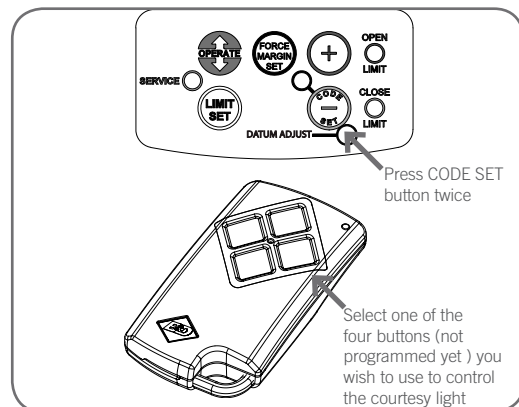

Fig. 34

Coding Transmitters

Fig. 35

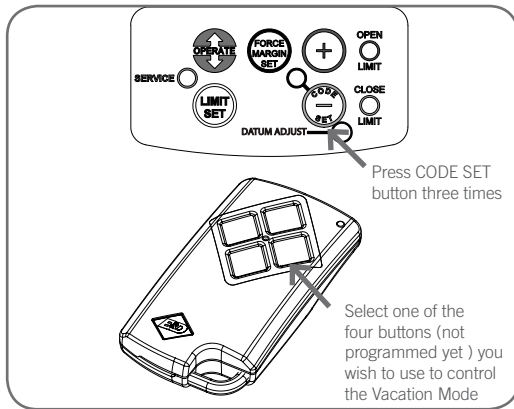
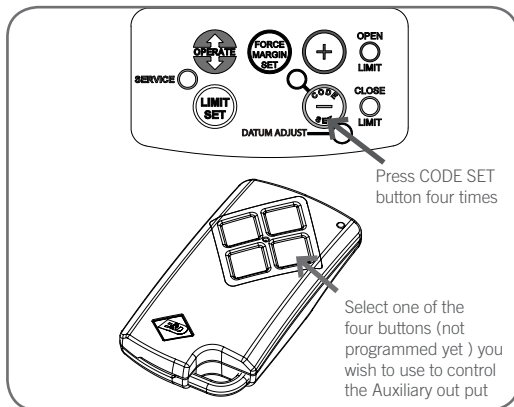

Fig. 36



Step 17.3 - Setting the Transmitter to Operate Vacation Mode

The opener can be programmed into a “Vacation Mode” where the opener will not respond to any transmitter except one preprogrammed unit.

- Press CODE SET button three times. The CODE SET LED will illuminate and the courtesy light will flash slowly (once every two seconds) to indicate Vacation learning mode is active. (Fig. 35)
- Choose a transmitter button not already coded into the receiver. Press this button and the CODE SET LED will begin to flash.
- Press the same transmitter button again. The CODE SET LED will illuminate for one second and then go out, and the courtesy light will also switch off. This indicates the code has been stored (Fig. 35).
- To activate Vacation Mode, close the garage door and press the coded button transmitter for 5 seconds. The CODE SET LED will illuminate and beep x 2 to indicate that the opener is in Vacation Mode.
- To exit Vacation Mode press the transmitter button momentarily until the CODE SET LED turns off and beeps x 1.

Step 17.4 - Setting the Transmitter to Operate the Auxiliary Output

It is possible to operate other devices (e.g. alarm systems) using one of the spare buttons of a multi-channel transmitter coded into the Auxiliary Output feature.

- Press CODE SET button four times. The CODE SET LED will illuminate and the courtesy light will flash quickly (twice per second) to indicate that learning mode for the Auxiliary Output is active.
- Choose a transmitter button not already coded into the receiver. Press this button and the CODE SET LED will begin to flash.
- Press the same transmitter button again. The CODE SET LED will illuminate for one second and then go out, and the courtesy light will also switch off. This indicates the code has been stored (Fig. 36).

Coding Transmitters

Step 17.5 - Setting the Transmitter to Operate Pet (Pedestrian) Mode

The opener can be programmed into a "Pet Mode" where the door opens partially to allow pets to enter/exit the garage:

- Press the CODE SET button five times, the CODE SET LED will illuminate and the courtesy light will flash quickly (twice per second) to indicate learning mode for Pet Mode is active.
- Choose a transmitter button not already coded into the receiver. Press this button and the CODE SET LED will begin to flash.
- Press the same transmitter button again. The CODE SET LED will illuminate for one second and then go out, and the courtesy light will also switch off. This indicates the code has been stored. This indicates the code has been stored (Fig. 37).

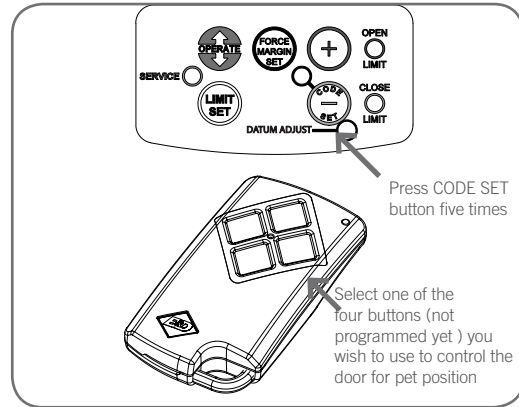

Fig. 37

Step 17.6 - To Erase Programmed Codes

If the CODE SET button is pressed and held for 6 seconds the CODE SET LED will blink rapidly for one second to indicate that all programmed codes have been erased. (Fig. 38)

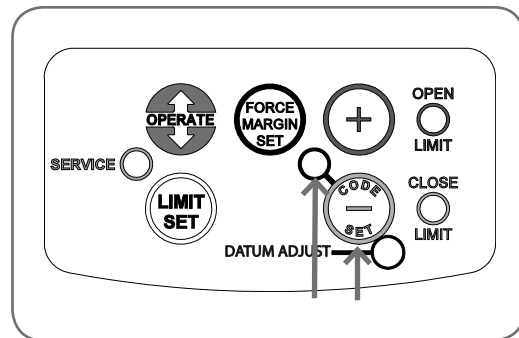

Fig. 38

Step 17.7 - Installation of the Wall Mounted Transmitter

- Mount the transmitter in a convenient location, yet out of reach of children and at least 1.5m off the ground (Fig. 39).
- Make sure the door is visible from this location.
- To set the transmitter codes refer to Step 17.1 on page 19.

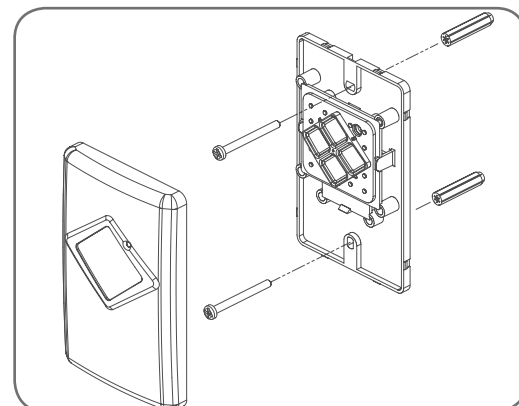
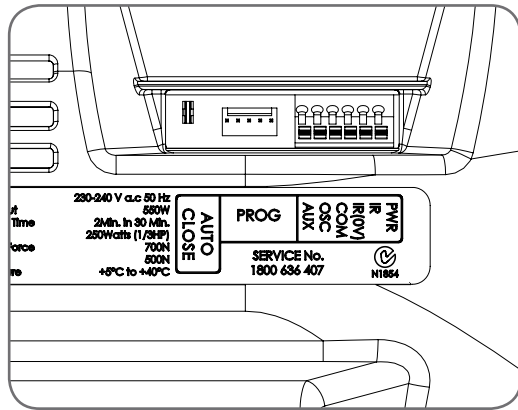

Fig. 39

Accessories

Fig. 40



Terminal Block

A variety of wired accessory items can be connected to the terminal block such as Safety Infra-red Beams, wall switch, door status indicator and more.

The terminal block also features an auxiliary output for controlling other devices from your transmitter. These can include: an alarm system, external lighting, or an automatic gate.

Terminal connections are as follows (**Fig. 40**):

1. PWR (+ve)
2. IR (Safety Infra-red Beam input)
3. IR(OV) (Common for Safety Infra-red Beam)
4. COM (Common -ve ground for accessories)
5. OSC (Open/Stop/Close trigger)
6. AUX (Auxiliary output trigger)

Remote Aerial (Part No 062177)

Some sites cause poor radio reception. Particularly problematic areas are those where there is a large amount of metal, like an all steel garage, or an underground car park with large masses of steel reinforced concrete. These issues, and others, can create radio reception issues.

Poor radio reception will be noticed by a reduction in the operating range of the transmitters.

You can evaluate whether fitting an external aerial will benefit as follows:

- test the maximum operating range of the transmitter with the garage door closed; then
- test the maximum operating range of the transmitter with the garage door open.

If the range improves when the door is open you can install a remote aerial kit to improve reception.

Mount the aerial to a suitable location on the outside of the garage. Similar to a television aerial, the better the mounting position the better the reception will be. Where possible, mount the aerial as high as possible, away from masses of metal and in a line of sight position to where you normally use your transmitter.

Accessories

Safety Infra-red Beam (Part No 062734)

For **ADDITIONAL PROTECTION** B&D Doors **STRONGLY** recommend the fitting of a Safety Infra-red Beam. In most countries Safety Infra-red Beams are mandatory on all garage doors fitted with automatic openers. For a small additional outlay, B&D recommends that Safety Infra-red Beams be installed with the automatic opener ensuring additional safety and peace of mind.

IMPORTANT NOTE - The Safety Infra-red Beam must be installed and connected before the travel limits are set - See Step 7.

WARNING: Doors requiring over 400N of force to move must have Safety Infra-red Beams fitted for safety.

Locate the Safety Infra-red Beam in a strategic location within the doorway. It is recommended that it be positioned

- 150mm above the floor level
- as close as possible to the door opening
- inside the garage

Make sure to align the beams correctly. Follow the manual supplied with the Safety Infra-red Beams. Connect the wires to the terminal block as per (Fig. 41).

WARNING: When using Auto-Close mode and Safety Infra-red Beams, the doorway must be clear of all obstructions and persons at all times.

WARNING: Automatic door - The door may operate unexpectedly, therefore do not allow anything to stay in the path of the door.

CAUTION! The location of the beam and manner in which it is installed might not give safety protection at all times. Check to make sure that the height of the beam and type used give maximum protection possible.

Electric Key Switch (Part No 062738)

An electric key switch provides an alternative to using a transmitter. Each key turn cycles through an open/stop/close function. The electric key switch is also an external release mechanism - ideal for garages only one entrance. To connect the switch to the opener's terminal block refer to (Fig. 42) and the Electric Key Switch's instruction sheet.

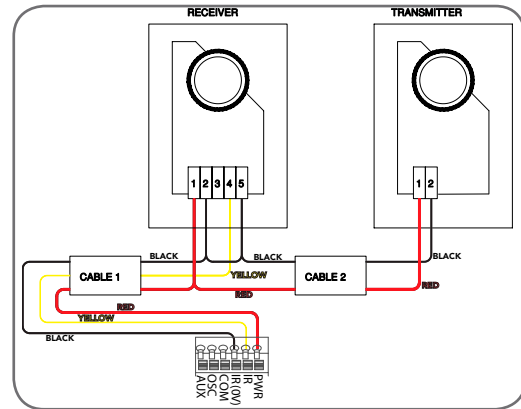

Fig. 41

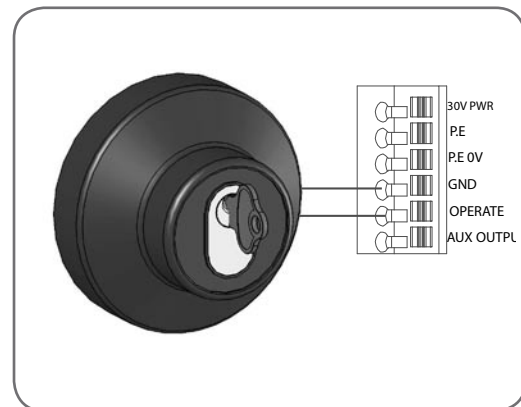

Fig. 42



How To Use Your Opener

Fig. 43

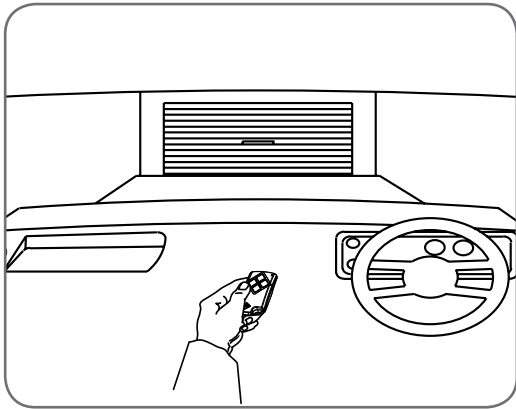
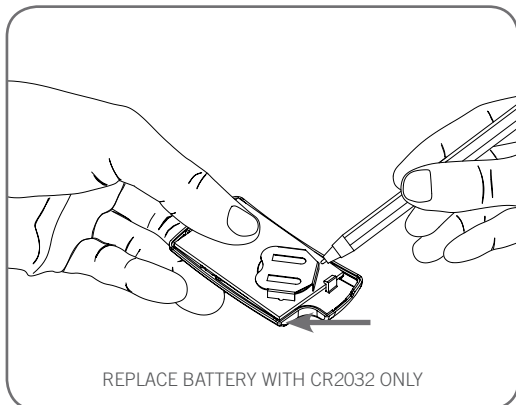

Fig. 44



For maximum efficiency of your opener, your garage door must be in good operating condition. An annual service of your garage door by an Approved Dealer is recommended.



CAUTION - Activate the opener only when the door is in full view, free of obstructions and with the opener properly adjusted. No one should enter or leave the garage while the door is in motion. Do not allow children to play with or near the door.



WARNING! This opener is a mains voltage plug-in domestic appliance and there are no user serviceable parts inside this opener.

Transmitter

- To operate the opener, press the programmed transmitter button until your door begins to move (usually 2 seconds). Make sure you can see the door when you use the transmitter.
- If you are in a vehicle you should aim the transmitter through your windscreen (**Fig. 43**).
- Check that the door is fully closed before you drive away.
- If you press the transmitter whilst the door is moving the door will stop. The next press of the transmitter will move the door in the opposite direction.

The transmitter may also be programmed to operate the following features (see Pages 19 to 21 for more details):

- turn the courtesy light on and off
- to activate the Auxiliary Output,
- to put the door into "Pet Mode" where it opens partially to allow pet access to the garage, and/or
- to put the garage door opener into "Vacation Mode" where it will not respond to any transmitters.

NOTE: Extra transmitters may be purchased at any time.

Removing the Battery From the Transmitter

(Battery Type: 3V Lithium Battery CR2032).

Use a non-metallic object to remove the battery. (**Fig. 44**)

Inbuilt Locking Facility

DO NOT lock your door when your opener is engaged as it has inbuilt locking facility. With the opener engaged your door will be locked whether the power is on or off.

How To Use Your Opener

Manual Door Operation



CAUTION: Do not open manual release in the open position, only use in the closed position. Operating the manual release while the door is open, the door may fall rapidly due to weak or broken springs, or due to being improperly balanced.



CAUTION! Do not disengage the opener to manual operation with children/persons or any objects including motor vehicles within the doorway.

To disengage the opener from the door (preferably with the door in the closed position), pull down on the string handle on an angle towards the door. This will allow you to manually open or close the door. To re-engage the opener pull the string handle away from the door.



WARNING! When the opener is manually disengaged, the door is no longer locked. To lock the door manually, re-engage the opener after the door is closed.

Power Failure

When there is a power failure, the opener will be unable to automatically open or close your garage door. To use your door whilst there is no power you will need to disengage the opener and use the door manually – see Manual Operation above.

Safety Infra-red Beam

A Safety Infra-red Beam Kit (Part No 062734) may be fitted to this opener.

- When this option is fitted, the operation of this device is such that if an object (i.e. car, child, etc.) blocks the Safety Infra-red Beam, then the garage door opener will not close the door automatically.
- If the Safety Infra-red Beam is fitted but not operating correctly, then the door once opened automatically, will not close automatically. The door may be closed by reverting to manual operation – see Manual Operation.

Auto-Close Option

To have the Auto-Close option functional you must also have a Safety Infra-red Beam (Part No 062734) fitted and functioning. To enable the Auto-Close function, place the AUTO-CLS jumper near the terminal block.

When this option is selected the garage door opener will attempt to close the door automatically 30 seconds after opening.

If the Safety Infra-red Beam is interrupted whilst the door is closing (e.g. by a person walking through the doorway), the door will reverse to the fully open position.

If the door does not close automatically, you may close the door using the Manual Operation.

Courtesy Light

The Courtesy Light will illuminate for approximately four (4) minutes each time the door is operated automatically.

Spare buttons of a multi-channel transmitters can be programmed to turn the light on and off by remote control.

See Step 17.2 for more information.

Auxiliary Output

This function allows the opener to operate other devices such as external lights or an alarm system.

To use this function, a spare button of a multi-channel transmitter must be programmed to operate the Auxiliary Output feature.

See Step 17.4 for more information.

Vacation Mode

The radio receiver of the garage door opener can be turned off to all but one transmitter via Vacation Mode. Whilst in vacation mode the opener will not respond to any transmitter.

To activate the Vacation Mode facility, see Step 17.3.

NOTE - program only one button to control "Vacation Mode". This will reduce the possibility of accidental activation of this feature.

Pet (Pedestrian) Mode

A transmitter can be programmed to open the door partially to allow pet access to the garage.

To activate Pet Mode press the transmitter button that has been programmed for Pet Mode - the door will open partially.

See Step 17.5 for more information.

Troubleshooting Guide

Symptom	Possible cause	Remedy
The opener does not work from the transmitter	Garage door in poor condition e.g. springs may be broken	Check the door's operation - see monthly maintenance (Page 27)
	The opener does not have power	Plug a device e.g. a lamp, into the power point and check that it is OK. Possible cause blown fuse
	The battery in the transmitter is flat	Replace the battery (Page 25)
	The opener has been put into "Vacation Mode"	Turn off "Vacation Mode" (Page 20)
	The transmitter code has not been set	See transmitter & code setting procedure (Page 19)
The motor runs but the door does not move	The opener is disengaged	Re-engage the opener (Page 25)
The transmitter range varies or is restricted	Variations are normal depending on conditions e.g. temperature or external interference	See Instructions for correct use of transmitter (Page 24)
	The battery is flat or faulty	Replace the battery (Page 25)
	Position of the transmitter in the motor vehicle	Change the position (Page 24)
	Position of the aerial will not pick up the radio signal	Install an external aerial kit – see Accessories (Page 22)
The light does not work	Light module is not inserted/connected properly	Check for correct connection otherwise contact your dealer for support
The door reverses for no apparent reason	This may occur occasionally from weather changes or poor door balance	The opener automatically adjusts to compensate for changes, to adjust the force see (Page 18)
The door opens but will not close	Auto-Close or Safety Infra-red Beam not operating correctly	Check the installation (Page 26) otherwise contact your dealer for support

If You Need a Service Call

If the opener needs service please call the dealer who installed the garage door opener (for product assistance contact 13 62 63 within Australia).

BEFORE CALLING you should have the following information to assist in providing the appropriate service:

1. Has anything happened since the opener last operated OK, e.g. a storm, a jolt to the door etc.?
2. How easy is it to manually open and close the door?
3. What model is the opener?
4. Who installed the opener?
5. When was it installed?

Fault Indicator

When a fault is detected the SERVICE LED will start to flash and a number of beeps will sound to indicate that there is a fault. The fault will be active each time an attempt is made to operate the door.

Pressing the LIMIT SET button will reset the opener. If the fault continues to be tripped contact an Approved Dealer for assistance.



Parameters

Door status indicators

Door opener state	OPEN LED (green)	CLOSE LED (red)	Beeper
Open	On		
Close		On	
Opening	Flashing		
Closing		Flashing	
Door travel stopped	Flashing	Flashing	
Door obstructed when opening	Flashing		
Door obstructed when closing		Flashing	Beeps while door is moving
Opener overloaded	Alternating flashes	Alternating flashes	
Door in open position with Auto-Close mode selected	One second flashes		
Mains power interrupted	Rapid flashes		

Button	Function
OPERATE	Opens/stops/closes the door
CODE SET	Codes a transmitter button for operate function
FORCE MARGIN SET & PLUS (+)	Increases the obstruction force margin setting
FORCE MARGIN SET & MINUS (-)	Decreases the obstruction force margin setting
FORCE MARGIN SET (then) LIMIT SET	Reloads the factory set default obstruction force margin setting
LIMIT SET (for 6 seconds)	Clears the door limits set positions. Limits then need to be reset
LIMIT SET (the power on) and hold until all LEDs are off	Deletes control parameters excluding transmitter storage memory
CODE SET press and hold until DOOR CODE LED starts flashing	Deletes all transmitter storage memory
LIMIT SET & CODE SET (the power on) and hold until all LEDs are off	Deletes all control parameters and transmitter storage memory



Maintenance

Maintenance

The SERVICE LED will indicate the requirement for a service and/or adjustment. To reset the SERVICE LED when the door is serviced, reprogram the Door Travel Limits and the Door Travel Force – on completion of this programming the SERVICE LED will go out.

Whilst your opener does not require any periodic maintenance, the door that it is fitted to does. Your garage door is a large, heavy, moving object and should be tested regularly to ensure it is in good condition. A poorly maintained door could cause fatal or serious injuries or serious damage to property.

To ensure a long and trouble free life for your opener the following is recommended:

Monthly

- Disengage the opener and manually operate the door: The door must be smooth to operate by hand. An operating force on the bottom rail should not exceed 150N (15kg) force.
- Each month check that the opener reverses when the door contacts a 40mm high object placed on the floor. Refer to Testing the Safety System (Step 16).

NOTE: If the door does not operate smoothly, call your nearest Approved Dealer.

Yearly

B&D suggests that you contact your nearest Approved Dealer to perform an annual door service.

Service Record

Record any maintenance in the following table to assist in any warranty service.

Date	Service by	Signature	Invoice No.	Amount



CAUTION: Frequently examine door, particularly cables, springs and mountings for signs of wear, damage or imbalance. Do not use if repair or adjustment is needed since a fault in the installation or an incorrectly balanced door may cause injury.

Adjustments should only be carried out by experienced persons, as this function can be dangerous if not performed under strict safety procedures.



WARNING! Failure to maintain your garage door may void the warranty on your garage door opener.

Warranty Expired Indicator

When the opener reaches the number of cycles covered by warranty the courtesy light will flash 10 times after each operation to indicate that the warranty has expired. This flashing will continue for twenty (20) operations unless the user acknowledges the warranty expiry indicator and stops the light from flashing. To stop the courtesy light flashing press the LIMIT SET button while the light is flashing after an operation.



Spare Parts

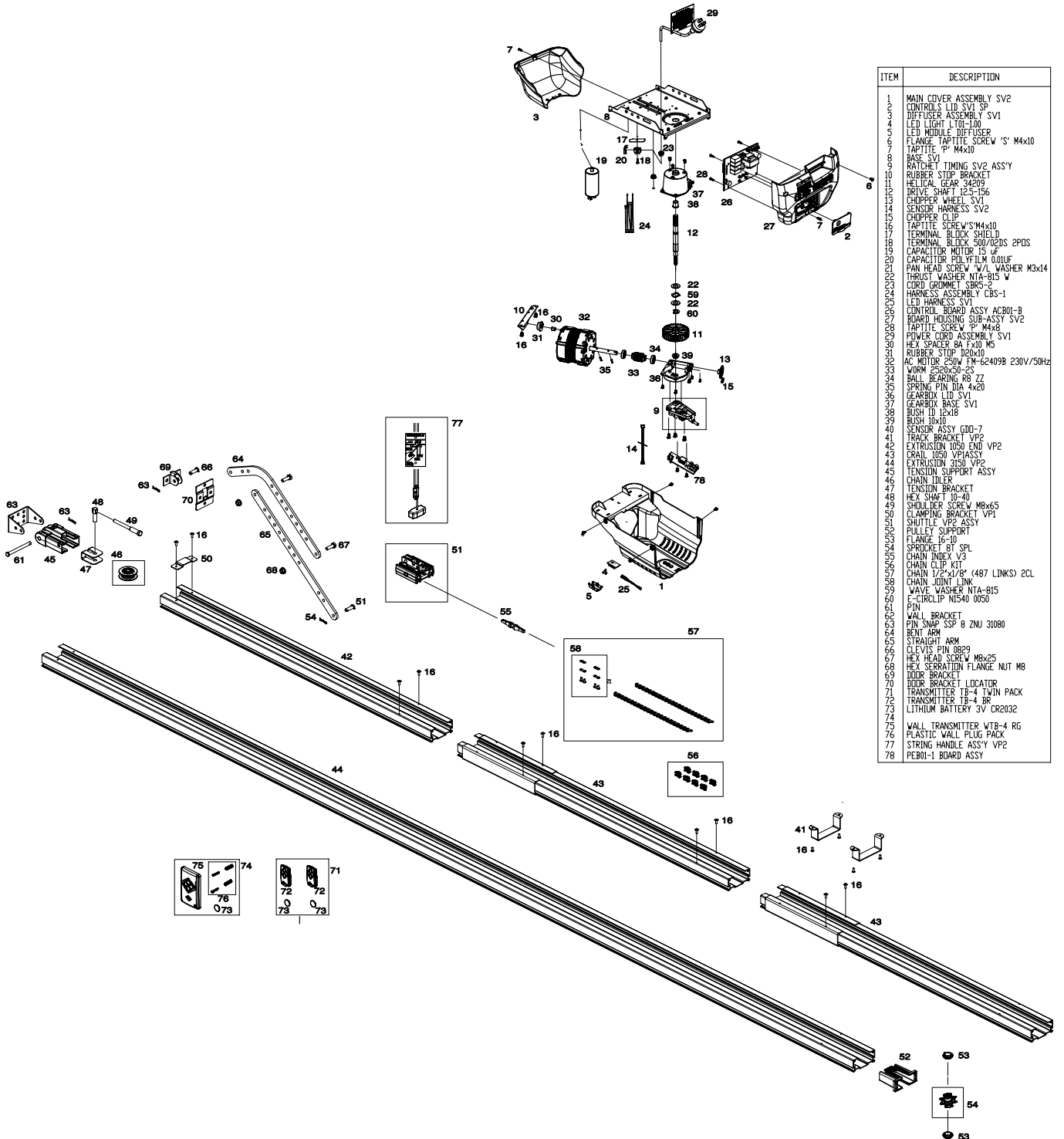

ITEM	DESCRIPTION
1	MAIN COVER ASSEMBLY SV2
2	CONTROLS LID SV1 SP
3	DIFFUSER ASSEMBLY SV1
4	LED LIGHT L10-100
5	LED MODULE DIFFUSER
6	FLANGE TAPTITE SCREW 'S' M4x10
7	TAPTITE 'P' M4x10
8	BASE SV1
9	RATCHET TIMING SV2 ASSY
10	RUBBER STOP BRACKET
11	HELICAL GEAR 34209
12	DRIVE SHAFT 12.5-156
13	CHOPPER WHEEL SV2
14	SENSOR HARNESS SV2
15	CHOPPER CLIP
16	TAPTITE SCREWS M4x10
17	TERMINAL BLOCK SHIELD
18	TERMINAL BLOCK 500/02DS 2POS
19	CAPACITOR MOTOR 15 UF
20	CAPACITOR POLYFILM 100UF
21	PAN HEAD SCREW W/L WASHER M3x14
22	THRUST WASHER NTA-B15 W
23	CORD GROMMET CSRS-2
24	HARNESS ASSEMBLY CBS-1
25	LED HARNESS SV1
26	CONTROL BOARD ASSY AC801-B
27	BOARD HOUSING SUB-ASSY SV2
28	TAPTITE SCREW 'P' M4x8
29	POWER CORD ASSEMBLY SV1
30	HEX SPACER 14x10 M3
31	RUBBER STOP D20x10
32	AC MOTOR 250W TM-62409B 230V/50Hz
33	WORM 2520x30-2S
34	BALL BEARING R8 Z2
35	SPRING PIN DIA 4x20
36	GEARBOX LID SV1
37	GEARBOX BASE SV1
38	BUSH ID 12x18
39	BUSH ID4x8
40	SENSOR ASSY GDO-7
41	TRACK BRACKET VP2
42	EXTRUSION 1050 END VP2
43	CRAIL 1050 VP2ASSY
44	EXTRUSION 3150 VP2
45	TENSION SUPPORT ASSY
46	CHAIN IDLER
47	TENSION BRACKET
48	HEX SHAFT 10-10
49	SHOULDER SCREW M8x65
50	CLAMPING BRACKET VP1
51	SHUTTLE VP2 ASSY
52	PULLEY SUPPORT
53	FLANGE 16-10
54	SPURCKET BT SPL
55	CHAIN INDEX V3
56	CHAIN CLIP KIT
57	CHAIN 1/2"x1/8" (487 LINKS) 2CL
58	CHAIN JOINT SV1
59	WAVE WASHER NTA-B15
60	E-CIRCLIP N1540 0050
61	PIN
62	WALL BRACKET
63	PIN SNAP SSP 8 ZNU 31080
64	BENT ARM
65	STRAIGHT ARM
66	CLEVIS PIN 0829
67	HEX HEAD SCREW M8x25
68	HEX SEPARATION FLANGE NUT M8
69	DOOR BRACKET
70	DOOR BRACKET LOCATOR
71	TRANSMITTER TB-4 TWIN PACK
72	TRANSMITTER TB-4 BR
73	LITHIUM BATTERY 3V CR2032
74	WALL TRANSMITTER WTB-4 RG
75	PLASTIC WALL PLUG PACK
76	STRING HANDLE ASSY VP2
77	PE801-1 BOARD ASSY
78	



Warranty

1. Definitions

'B&D' means

(a) in Australia - B&D Doors of 17 Oasis Court, Clontarf, Queensland, 4019, a division of B&D Australia Pty Ltd (ABN 25 010 473 971), or

(b) in New Zealand - B&D Doors NZ Ltd of 70 Allens Road East Tamaki Auckland, which is a subsidiary of B&D Australia Pty Ltd.

'Purchaser' means the purchaser of the Opener.

'Opener' means the 'Controll-A-Door® Sectional Door Opener'

'Approved Distributor' means a reputable reseller of B&D products purchasing on an open account from B&D, for the purpose of supplying and installing those products to end users.

'Major Components' means all components of the Opener that make up the powerhead, including any track assembly, if any, that is attached to a garage door.

'Ancillary Components' means all components of the Opener which are not Major Components.

'Manufacturer's Written Instruction Manual' means the instruction manual provided with the Opener.

2. This warranty applies to every sale of an Opener to a Purchaser by B&D or its Approved Distributor, and is the only warranty given on behalf of B&D.
3. B&D warrants that it will, at its option, either repair or replace any defects:
 - (i) in materials or workmanship in the Opener, subject to the following:
 - (a) for Major Components of the Opener that are installed by B&D or an Approved Distributor the warranty shall be valid for a period of sixty (60) months or 10,000 cycles (whichever occurs first);
 - (b) for Major Components of the Opener that are not installed by B&D or an Approved Distributor the warranty shall be valid for a period of twelve (12) months, provided that all costs of disconnection, reinstallation and freight shall be borne by the Purchaser.
 - (c) For Ancillary Components of the Opener the warranty shall be valid for a period of twelve (12) months.
 - (ii) in installation for a period of twelve (12) months from the date of installation where the Opener has been installed by B&D or its Approved Distributor.
4. The warranties provided in clause 3(i) shall only apply to an Opener which is being used under normal use and service in accordance with the Manufacturer's Written Instruction Manual and are limited to the repair or replacement, at B&D's option, of any defective Opener or parts thereof.
5. The warranty provided in clause 3(i) shall apply from:
 - (i) the date of delivery of the Opener by B&D; or
 - (ii) the date of installation of the Opener by B&D or one of its Approved Installers; or
 - (iii) the date of purchase of the Opener by the Purchaser;whichever is the later.
6.
 - (i) Where the Opener has been sold to the Purchaser by B&D, the Purchaser shall make all warranty claims hereunder directly with B&D;
 - (ii) Where the Opener has been sold to the Purchaser by an Approved Distributor, the Purchaser shall make all warranty claims hereunder directly with the Approved Distributor.
7. The Purchaser will pay for any service call made by B&D or an Authorised Distributor where such a call is made for the purpose of adjustment (as described in the Manufacturers Written Instruction Manual) and not for rectification of a defect pursuant to the warranty hereunder.
8.
 - (i) The Purchaser shall be responsible for any expense incurred by B&D or an Approved Distributor in ensuring that the Opener is readily accessible for any repair work carried out under this warranty. Where an Opener is installed outside a capital city metropolitan area and a warranty claim is made pursuant to this warranty, any travelling expenses and costs of transporting the Opener, incurred by B&D or its Approved Distributor, shall be borne by the Purchaser.



Warranty

9. Subject to paragraph 12 hereof;
 - (i) the obligations of B&D under this warranty are limited to those contained herein and such warranties are expressly in lieu of all other warranties, express or implied, including any implied warranty of merchantability or fitness for a particular purpose and notwithstanding any course of dealing between the parties or custom and usage in the trade to the contrary.
 - (ii) B&D shall not be subject to nor incur and the Purchaser releases B&D from any claim or liability (including consequential loss or damage and loss or use or profit) by reason of delay, defective or faulty materials or workmanship, negligence or any act, matter or thing done, admitted or omitted by B&D.

10. Subject to Clause 12 hereof, this warranty does not extend to and B&D will be relieved of all obligations, responsibilities and liabilities (direct or consequential) in the event that defects in manufacture of the Opener are directly or indirectly in the opinion of B&D due to or result from:
 - (i) being fitted to any door or other closing device which is not of the type or condition defined in the Manufacturers Written Instruction Manual as suitable for installation of the Opener.
 - (ii) Lack of proper maintenance or care – failure to have the door serviced annually may void this warranty.
 - (iii) Incorrect and unreasonable use.
 - (iv) Faulty installation or adjustment of the Opener or door to which the Opener is connected where such installation or adjustment is not carried out by B&D or one of its Approved Distributors.
 - (v) Failure to observe any instructions or directions provided with the Opener or given to the Purchaser by B&D or an Approved Distributor.
 - (vi) Modifications or repairs made or attempted to be made by any unauthorised person.
 - (vii) Faulty electrical wiring of structures to which the Opener is affixed.
 - (viii) Radio (including citizen band transmissions) or other electronic interference.
 - (ix) Water damage, including effects from rust and corrosion.
 - (x) Use with doors locked.

11. The warranty contained in Clause 3 does not cover batteries, globes, LED lights and B&D shall not be liable for any defect, malfunction or failure of such items.

12. It is expressly provided that the warranties or any terms and conditions of them or other statement contained in this document or other literature given to the Purchaser shall not be read or applied so as to purport to exclude, restrict or modify or have the effect of excluding, restricting or modifying the application in relation to the supply of the Opener of all or any of the provisions of Divisions 2 and 2A of Part V of the Trade Practices Act, 1974, or the Consumer Guarantees Act 1993 if the purchase is a 'consumer' and purchased the opener in New Zealand, ("The Act") as amended or the exercise of a right conferred by such a provision or any other condition or warranty implied by any relevant State Act or Territorial Ordinance or by the general law and which by law cannot be excluded, restricted or modified provided that to the extent that the Act permits B&D to limit its liability for a breach of condition or warranty implied by the Act, B&D's liability for such breach shall be limited to the payment of the cost of replacing the Opener or acquiring an equivalent Opener or repairing the Opener.

13. This warranty shall be governed by and construed in accordance with Australian law if the opener was purchased in Australia, or New Zealand law if the opener was purchased in New Zealand.

14. Upon making a claim under this warranty the purchaser must produce proof of the date of purchase, together with the details set out below:

Purchased From: _____
Installed By: _____
Installed Date: _____

The Purchaser shall complete this certificate and keep it together with a copy of the receipt of purchase in a safe place – production of such information will assist the handling of a claim made under this warranty.



QLD Office: 17 Oasis Court, Clontarf 4019. Ph: (07) 3883 0200
NSW Office: 34-36 Marigold St, Revesby 2212. Ph: (02) 9722 5555
VIC/TAS Office: 147-153 Canterbury Road, Kilsyth 3137. Ph: (03) 9237 7766
SA Office: 23 Frederick Road, Royal Park 5014. Ph: (08) 8440 4747
WA Office: 96 Mulgul Drive, Malaga 6062. Ph: (08) 9247 8777
www.bnd.com.au
NZ Office: 70 Allens Road, East Tamaki, Auckland. Ph: (09) 273 8600
www.bnd.co.nz

B&D Doors is a division of B&D Australia Pty Limited - ABN 25 010 473 971

©Copyright January 2008 B&D Doors. All Rights Reserved. ® and TM are registered trademarks of B&D Australia Pty Ltd. In an ongoing commitment to product quality B&D Doors reserve the right to change specifications without notice. E&OE.

