

Installation Instructions

G900 Linear swing gate operator (discontinued)

The Merlin G900 linear actuators are a compact, streamlined design that provides good performance and quiet operation on small to medium sized gates. The anodised aluminium finish protects the drive system from the weather, ensuring low maintenance. Suitable for single or double swing gates and provide years of reliable service.

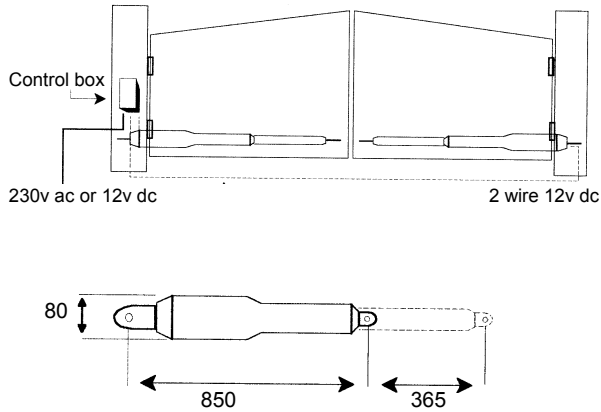

Specs

Power options	230v. ac, 12v. dc, solar
Current	3 amp per motor
Maximum duty cycle	100%
Travel time	18-20 seconds
Maximum gate weight / length	180Kg / 3 meters
Maximum opening angle	110 deg
Gate stops required	Yes
Gate lock required	optional

Standard features

- Auto close, adjustable 6-210 seconds
- Adjustable force sensitivity
- Leaf delay for electric locks or clash bars.
- Multi-use function.

Optional Accessories

- Battery back up
- Solar power option
- Safety beam sensors
- Electric lock
- Intercom
- Keypad entry.

Step 1

Fasten the motor securely to the gatepost, and the gate bracket to the gate as shown in fig A & B.

Correct geometry must be used.

Fig A
In swinging gates geometry

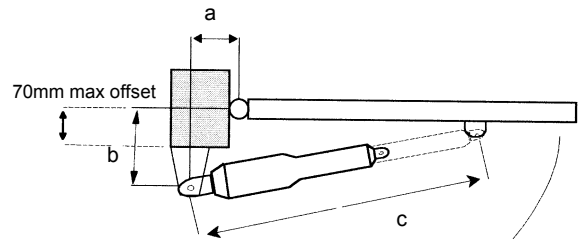

Opening angles	a	b	c
90 degrees	160mm	130mm	1215mm
110 degrees	160mm	100mm	1215mm

Fig B
Out swinging gates geometry

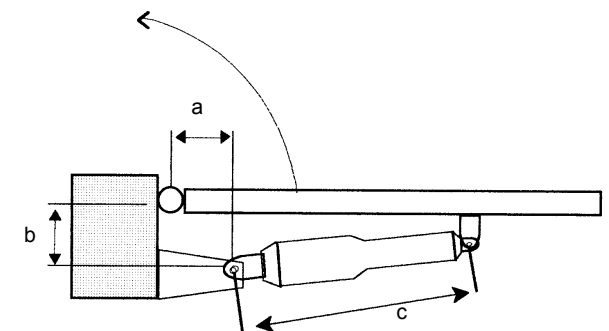

Opening angles	a	b	c
90 degrees	160mm	130mm	850mm
110 degrees	160mm	100mm	850mm

To enable the opener to extend out to the gate bracket, turn the manual release key.

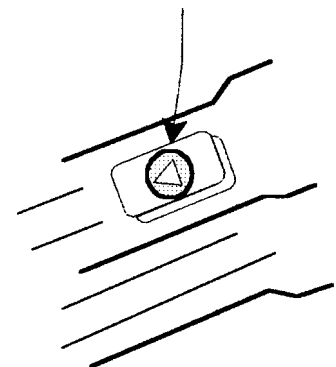

Step 2

Connect the wires to the control board

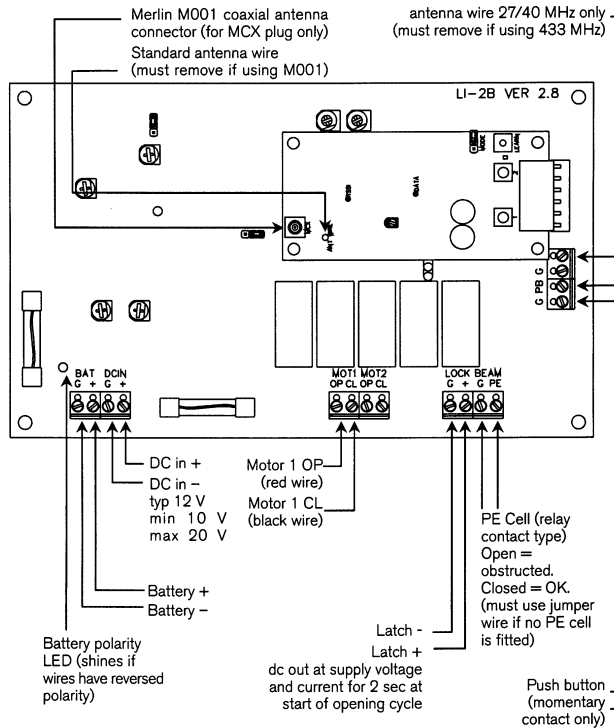

Note

When powering any accessories from the board, (for example: gate latches, additional receivers, keypads, and PE beams) ensure the power supply has adequate capacity. Measure the voltage at the DC IN under full motor load. If it falls below 9V then the board, receiver, and some accessories, may not function correctly. In this instance, remove accessories, upgrade the power supply, or provide additional power supplies directly to each accessory

Step 3

Connect the wires to the motors

Motor 1 is the left hand motor when facing out of the driveway. If motor 1 is on the right hand side, reverse the polarity of the motor wires.

If a single motor is fitted use the Motor 1 terminals. If a single opener is fitted on the right hand side, reverse the polarity of the motor wires.

If a motor pushes a gate outwards, reverse the polarity of the motor wires.

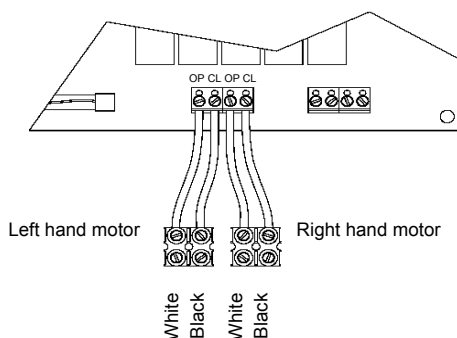

Step 4

Control board set up.

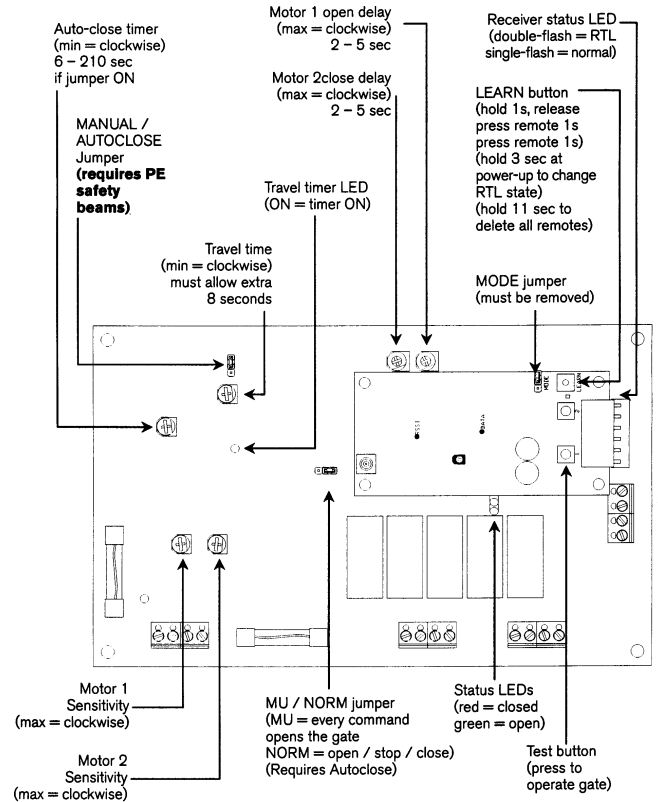

Operate the gates by either a remote control or a push button. The travel timer pot controls the operators. Adjust the timer so that the motor/s complete their full open and close cycle plus an extra 3 seconds of travel time. the motor clutches will slip and make a clicking sound during this period.

Note

Reverse motor wires if open and close LED's do not match gate travel.

Step 5

Set clutch torque level

There are two hex nuts on the under side of the motor housing. These are factory set at approx 20kg and may not require adjustment.

When the gates reach its stops the clutch should slip until the control board deactivates.

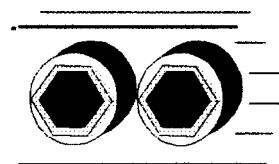

Note

The same adjustment should be made to both screws i.e.: if one nut is adjusted 1 turn clockwise, the other must have the same adjustment.