

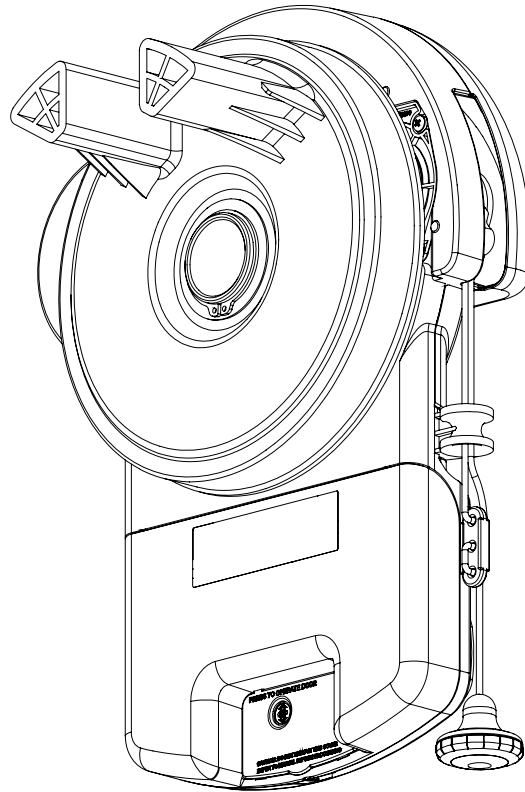

# GDO-6v4 EasyRoller®

## Roll Up Garage Door Opener

**Notes on how to set up to trigger another motor on this manual.**



Featuring **TrioCode™** Technology

aut<sup>o</sup>matic  
TECHNOLOGY

smart | simple | secure

Technical Document

Installation Manual

v **1.00**

19 July 2012

English

Part # 13238 (Manual)



**WARNING:** It is vital for the safety of people to follow all instructions. Failure to comply with the installation instructions and the safety warnings may result in serious personal injury and/or property and opener damage. Please save these instructions for future reference.

Automatic Technology (Australia) Pty Ltd to the extent that such may be lawfully excluded hereby expressly disclaims all conditions or warranties, statutory or otherwise which may be implied by laws as conditions or warranties of purchase of an Automatic Technology (Australia) Pty Ltd Roll Up Door Opener. Automatic Technology (Australia) Pty Ltd hereby further expressly excludes all or any liability for any injury, damage, cost, expense or claim whatsoever suffered by any person as a result whether directly or indirectly from failure to install the Automatic Technology (Australia) Pty Ltd Roll Up Door Opener in accordance with these installation instructions.



# GDO-6v4 EasyRoller®

## Roll Up Garage Door Opener

Important Safety Instructions	4
Features	6
Operating Controls	8
Package Contents	10
Installation	11
Programming the Opener	15
Safety Obstruction Force	17
Coding Transmitters	19
Deleting Transmitter Codes	21
Accessories	22
Wired Safety Beams Installation	22
Auto-Close	23
Final Setup	24
Setting of Courtesy Light Time	24
Setting the Pet Mode Position	24
Wall Transmitter Installation	24
Keyswitch Connection	24
Auxiliary Output	25
Reset all Factory Defaults	25
SmartSolar™ Installation	26
Battery Backup Kit Installation	27
Parameters	28
Door Status Indicators	28
Button Functions	29
Default Settings & Specifications	30
Troubleshooting	31
Maintenance	32
Spare Parts	33
Important Safety Checks	34
Warranty	35





# Important Safety Instructions

**WARNING: It is vital for the safety of persons to follow all instructions. Failure to comply with the following Safety Instructions may result in serious personal injury and/or property damage.**

**CAUTION:** If your garage has no pedestrian entrance door, an emergency access device should be installed. This accessory allows manual operation of the garage door from outside in case of power failure.

For **ADDITIONAL SAFETY** protection we **STRONGLY** recommend the fitting of a Safety Beam. In most countries, Safety Beams are mandatory on all garage doors fitted with automatic openers. For a small additional outlay, Automatic Technology recommends that Safety Beams be installed with the automatic opener ensuring additional safety and peace of mind.

**DO NOT** operate the opener unless the garage door is in full view and free from objects such as cars and children/people. Make sure that the door has finished moving before entering or leaving the garage.

**DO NOT** operate the opener when children/people are near the door. Children must be supervised at all times when the EasyRoller® is in use. **Serious personal injury** and/or property damage can result from failure to follow this warning.

**DO NOT** allow children to operate the EasyRoller®. **Serious personal injury** and/or property damage can result from failure to follow this warning.

**Photo Electric Beams** must be installed where the closing force as measured on the bottom of the door is more than 400N (40kgf).

Regularly check to make sure that the **Safety Obstruction Force** is working correctly, and is **tested** and set as per **page 17 of this manual**. Failure to follow these instructions could result in **serious personal injury** and/or property damage. This test must be repeated at regular intervals and the necessary adjustments made as required.

**DO NOT** disengage the door opener to manual operation with children/people or any other objects including motor vehicles within the doorway.

The door opener is not intended for use by young children or infirm persons without adequate supervision. Children should be supervised to ensure that they do not play with the remote transmitters or the opener.

Keep hands and loose clothing **clear** of the door and door opener at all times.



# Important Safety Instructions

The unit should be installed so that it is protected from the elements. It should not be exposed to water or rain. It is not to be immersed in water or sprayed directly by a hose or other device.

The garage door must be **well balanced**. Sticking or binding doors must be repaired by a qualified garage door installer prior to installation of the opener.

Frequently examine the installation, in particular cables, springs and mountings for signs of wear, damage or imbalance. **DO NOT** use if repair or adjustment is needed since a fault in the installation or an incorrectly balanced door may cause injury. **DO NOT** attempt to repair the door yourself as hardware is under extreme tension.

**Remove or disengage** all garage door locks and mechanisms prior to installation of the opener.

Connect the opener to a properly **earthed** general purpose 220V mains power outlet installed by a qualified electrical contractor.

**Disconnect the power cord** from mains power before making any repairs or removing covers. Only **experienced** service personnel should remove covers from the opener.

When using Auto-Close mode, a **safety beam** must be fitted correctly and tested for operation at regular intervals. **Extreme caution** is recommended when using Auto-Close mode. **All safety rules** must be followed.

In order for the EasyRoller® to **sense** an object obstructing the door way, some **force** must be exerted on the object. As a result the object, door and/or person may suffer **damage** or **injury**.

If the power supply cord is damaged, it **must** be replaced by an Automatic Technology service agent or suitably qualified person.

Make sure that the door is fully open before driving in or out of the garage and fully closed before leaving the driveway.

Make sure that remote transmitters are kept out of reach of children.

Install the (optional) wall switch or (optional) wall mounted transmitter in a location where the garage door is visible, but out of the reach of children at a height of at least 1.5 metres from the floor.





# Features

Thank you for purchasing the Automatic Technology EasyRoller® Automatic Garage Door Opener. Designed by our renowned engineers to suit Vertical Operating Continuous Curtain Roll up doors, the EasyRoller® will provide years of smart, simple & secure convenience to your home.

## Operation

To open or close the door simply press a button on a TrioCode™ handheld transmitter, a wall mounted transmitter, or optional wall switch for two seconds. During open and close cycles the door can be stopped by pressing the button again. The next actuation will move the door in the opposite direction.

## TrioCode™ Code Hopping Technology

Every time a TrioCode™ transmitter is used, a new security code is randomly generated from over 4.29 billion possibilities. This greatly enhances the security of the system and makes "code grabbing" a thing of the past.

These transmitters also overcome interference issues by simultaneously sending a signal over three slightly different frequencies. Even if two of the three signals are jammed, the system will still work.

## ALPS (Automatic Limits Positioning System)

ALPS does away with manual adjustment of the door's limits position using mechanical parts, such as cams and microswitches. During installation the handheld transmitter can be programmed to set the door limits positions.

## ISS (intelligent safety obstruction system)

While the door is performing a close cycle, should it hit an obstacle or be restricted in some manner, it will automatically reverse. The amount of force the door should encounter before reversing is automatically adjusted by the doors control system during the initial installation of the automatic door opener. The door will also stop if restricted whilst opening. The Safety Obstruction Force should be checked monthly.

## SmartSolar™ and Battery Backup Compatibility (optional)

The opener can be fitted with a SmartSolar™ or Battery Backup kit for operation in the event of a power outage, or where mains power access is not available.

**NOTE:** If the door is the only entrance to the garage, and a battery backup kit is not fitted, a keyed cable release should be fitted externally to the garage.





### **Vacation mode**

A handheld transmitter can be programmed to lock and unlock all other transmitters that have been programmed into the opener's memory. The vacation mode can be used when the door is left idle for long periods of time.

### **Auto courtesy light**

The courtesy light comes on automatically for three minutes whenever the door is activated. The light can also be operated independently of the door by coding a dedicated button on a transmitter.

### **Pet/Pedestrian mode**

The transmitter can be programmed to open the door to an adjustable partial height so that the family pet can enter and exit the garage at any time. You may also wish to open the door to a height suitable for pedestrian access.

### **Auto-Close mode**

The opener can be programmed to automatically close after an open cycle. The Auto-Close time is adjustable. It is compulsory to install a Safety Beam if this mode is selected, otherwise the door may cause personal injury or damage to property.

### **Safety Beam (optional)**

The opener has an input to connect a Safety Beam for extra safety and use of the Auto-Close mode. Easy Beam PE 3 kit or Wireless Safety Beam kit can be used with this opener.

### **Safety Beam Failure Emergency Close**

When a safety beam prevents movement due to any reason other than a 'real' obstruction, the user can secure their property by pressing and holding a button on the remote control or OSC on the console.

### **Manual operation**

The opener is equipped with a unique manual disengaging device. If the power to the opener is disrupted, the door can be put into manual mode by pulling down on the string handle on an angle towards the door. This allows for manual operation of the door. To re-engage the opener, pull the string handle away from the door.

### **Easy Access Transmitter**

Inside the manual release handle is a transmitter designed to be in easy reach so that the garage door can be operated without having to stretch to reach the operate button on the control panel.

### **Service Indicator**

The opener has a built in counter with a default setting of 3000 cycles. When the counter expires the opener will beep and flash to indicate a service is required.





# Operating Controls

- 01 TERMINAL BLOCK.**  
**V+** is used to power devices such as Wireless PE Beam, external receiver etc.  
**EB1** first Safety Beam input.  
**0V** (Input) is a 0 volt connection for PE Beam, external receiver, osc, aux etc.  
**EB2** second Safety Beam input.  
**0V** (Input) is a 0 volt connection for PE Beam, external receiver, osc, aux etc.  
**O/S/C** INPUT is used for the connection of a wired switch (momentary contact). This switch can then be used to open, stop or close the door. Install the wall switch in a location where the switch is out of reach of children and the garage door is visible.  
**AUX** output can be used to control another device (such as alarm system etc) via the opener's remote control.
- 02 LIGHT CODE** button (White) is used for storing or erasing the transmitter button (code) you wish to use to switch the courtesy light on the opener on or off.
- 03 CODING LED** (Red) light flashes when a code is being stored or when a transmitter button is pressed.
- 04 DOOR CODE** BUTTON (Blue) is used for storing or erasing transmitter buttons for door operation.
- 05 DOOR STATUS LED** (Yellow)
- 06 CLOSE** button (Red) is used during installation to help set the close limit position. Pressing and holding this button will move the door in the close direction. Movement stops when the button is released.  
**NOTE:** The safety obstruction detection is inoperable when the CLOSE button is used to move door.
- 07 CLOSE LIMIT LED** (Red) the LED is very helpful during installation. It illuminates and flashes when the door is closing and remains steady on when the close limit position has been reached.
- 08 AUTO CLOSE TIME** button (White) is used to adjust the Auto-Close time. Pressing the open button whilst pressing the Auto Close button increases length of operation. Each press will increase the time by 5 seconds. Pressing the close button will decrease the time.
- 09 FORCE MARGIN SET** button. The obstruction force margin is set automatically during installation. The margin can be adjusted manually using the Force Margin Set button (White). Holding the Force Margin Set button and pressing OPEN or CLOSE buttons will increase or decrease the amount of force. The Force Margin Set should only be used if environmental factors (wind, etc.) affect the door's operation.
- 10 OPEN LIMIT LED** (Green) the LED is very helpful during installation. It illuminates and flashes when the door is opening and remains steady on when the open limit position has been reached.
- 11 OPEN** button (Green) is used during installation to help set the open limit position. Pressing and holding this button will move the door in the open direction, releasing stops the door.  
**NOTE:** The safety obstruction detection is inoperable when the OPEN button is used to move door.
- 12 OPERATE** button (Yellow) is used during installation to test the open, stop and close cycles for the opener. The opener has to be initialised by the Reset button to make the O/S/C button operable.
- 13 SET** button (Yellow) is used during the installation phase together with the Open and Close buttons to set the door limit positions. The Set button is also used to re-initialize the Opener.
- 14 ENGAGE/DISENGAGEMENT CORD** enables manual door operation, especially useful during power failures. At the cord's end is the **EASY ACCESS TRANSMITTER**; a wireless door controller.
- 15 JP1 SOLAR CONNECTOR** the shunt must be fitted for solar operation.



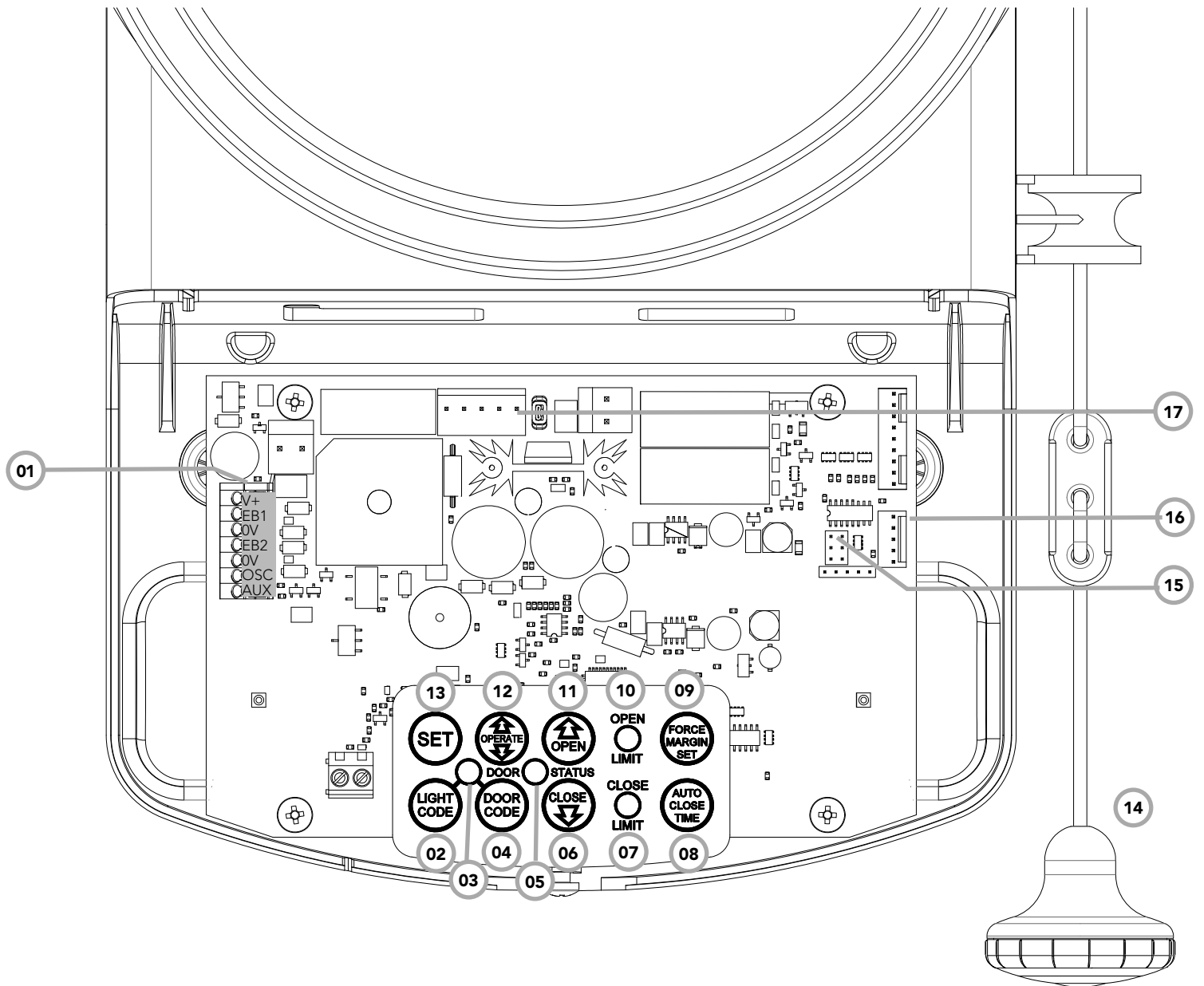

- 16 **PROG INPUT** is used to connect the Automatic Technology Handheld Programmer for editing control and receiver functions, accessing diagnostic tools, and activating special features and operating modes.
- 17 **SBCO-2 CONNECTOR** is used to connect both Battery Backup Kits and SmartSolar™ kits.





# Package Contents

GDO-6v4 Easyroller® drive unit w/ Easy Access Transmitter	1
TrioCode™ keyring transmitters with batteries	2
Pan head screw M4x50mm ( <i>not included in some models</i> )	2
Nilock Hex nut M4 ( <i>not included in some models</i> )	2
Flat washer I.D. 3/16 x 1/2 ( <i>not included in some models</i> )	2
Spring washer I.D. 5 ( <i>not included in some models</i> )	2
Locking bar covers	2
Weight bar ( <i>not included in some models</i> )	1
Installation Instructions	1

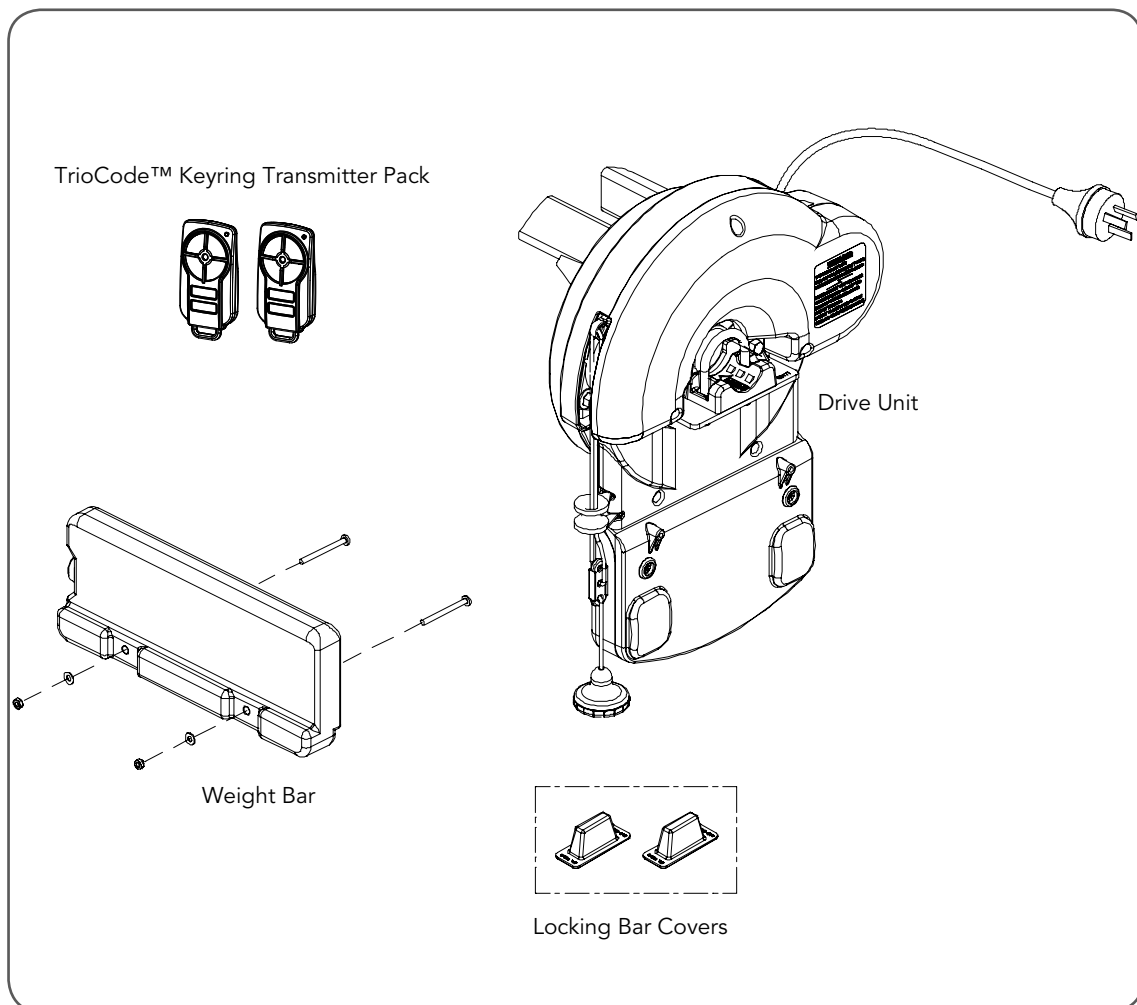



# Installation

## Pre-Installation Requirements

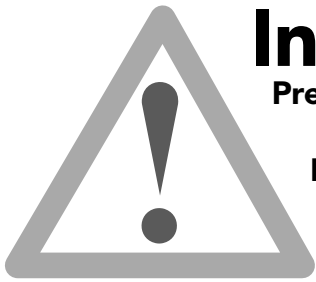

### IMPORTANT SAFETY INSTRUCTIONS FOR INSTALLATION

**Warning: Incorrect installation can lead to severe injury.  
Follow ALL installation instructions.**

#### Door Operation

The door must be in good operating condition. The maximum effort to move the door up or down, from stationary, should not exceed 150 Newtons (15kg force) at the bottom rail. The recommended force is 70N (7kg) for manual operation.

Lift the door to about halfway. When released, the door should stay in place supported entirely by its springs. Raise and lower the door to check for binding or sticking.

The door may need to be serviced to meet these requirements – refer to the door manufacturer’s servicing instructions or contact an authorised dealer.

#### Unsuitable Door Types

The fitting of an opener to doors with removable mullions is not recommended.



**IMPORTANT NOTE** - The opener should not be installed on any door incorporating a wicket door.

#### Position

The opener can be installed on either the right- or left hand side of the door (when viewed from inside the garage). The opener is factory set for right hand side installation.

This opener must be installed in a dry position that is protected from the weather. Moisture or corrosion damage is not covered by the Warranty.

#### Power Supply

Properly earthed 3 pin single-phase power is required.



**WARNING!** A portable power generator is not recommended. The opener may appear to malfunction due to spikes, surges and fluctuations in the generated voltage.

#### Sideroom

The minimum sideroom required from the edge of the door curtain is 40mm to the inside of the door bracket, and 85mm to the wall (**Fig. 01**). If a Battery Backup Kit is to be fitted, at least 135mm to the bracket is required (**Fig. 01a**).

The recommended sideroom from the edge of the door curtain is 95mm to the inside of the door bracket, and 135mm to the wall (**Fig. 02**).

**NOTE:** Door Axle Diameter must not exceed 35mm.

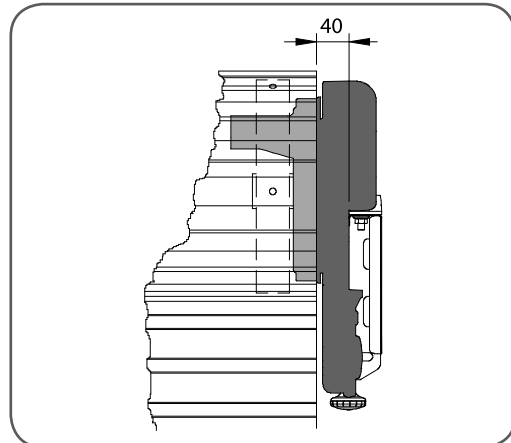

fig 01

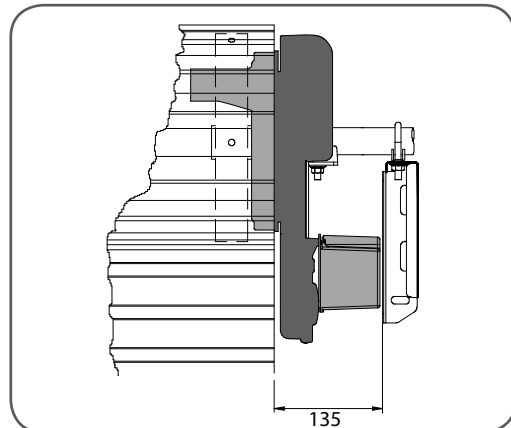

fig 01a

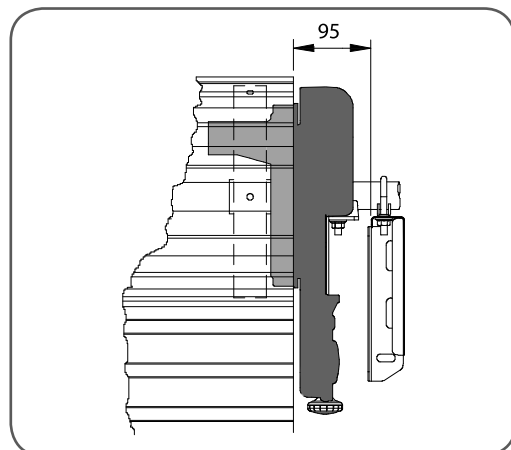

fig 02





# Installation

fig 03

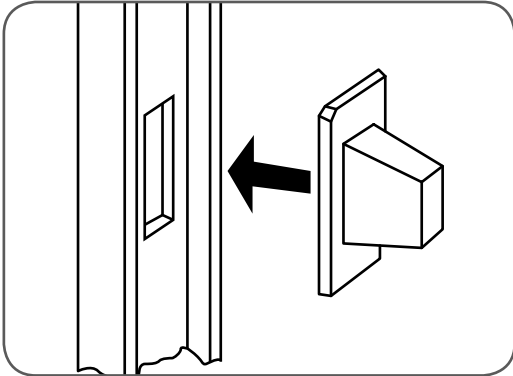

## Step 1 - Preparation

- a. Check the door's operation:
  - i. The door must travel smoothly and be easy to operate by hand.
  - ii. Operating force on the bottom rail should be approximately 70N (7kgs) force.
  - iii. Adjust any tight or twisted guides/tracks
  - iv. Clean the guides if there is any oil or wax present using a suitable white spirit. The only lubricant suitable for use on door guides is silicon spray. DO NOT use WD-40, RP-7, petroleum grease, or similar.
- b. Install the locking bar covers if there are locking bar holes in the guides. **(Fig.03)**



**IMPORTANT NOTE** - Do not lock your door with the locking bars after installing the opener. Remove or disable the lock using wire or cable ties. Security is not affected as the opener has an inbuilt locking facility.

fig 04

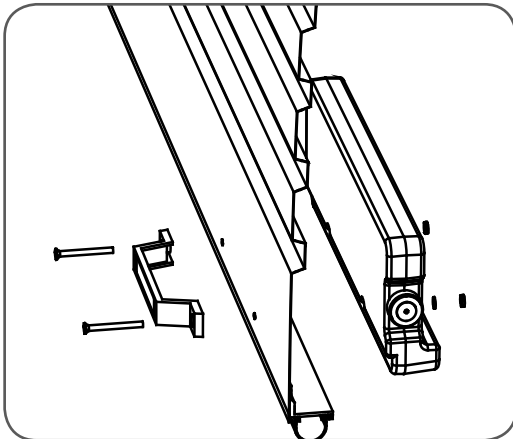

- c. Affix the warning labels supplied with this opener in a prominent place where they are clearly visible.
- d. Choose the side where the opener will be installed, ensuring there is sufficient sideroom.

## Step 2 - Fit the Weight Bar

The weight bar must be fitted to the bottom-centre for proper operation of the opener.

### If the door has a handle:

- a. Remove the door handle
- b. Fit the weight bar and refit the handle using the new fasteners provided **(Fig.04)**.

### If the door does not have a handle:

- a. Locate the centre of the door at the bottom rail **(Fig.05)**.
- b. Place the weight bar at this point (there is a centreline marked on the weight bar) and mark the two positions where the fasteners will go.
- c. Drill the two 4.5mm holes in the door and fit the weight bar using the new fasteners provided. **(Fig.06)**.

fig 05

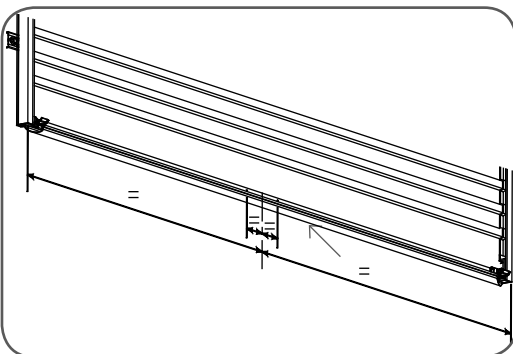
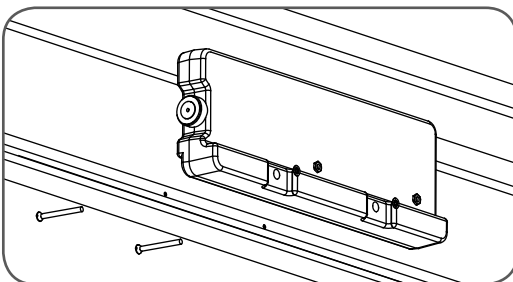

fig 06



Check that the door is still balanced and smooth to operate. If it is not, then the door may require servicing (refer to door manufacturer's instructions).



**WARNING!** The door and its springs are under significant tension. Adjustments should only be carried out by experienced persons, as this function can be dangerous if not performed under strict safety procedures.





# Installation

## Step 3 - Pin the Door Curtain

Pinning the door curtain to the door drum maintains security when the opener closes and locks.

- Fully close the door.
- Mark drill holes at both ends of the drum (**Fig. 07**).
- Drill holes using 3.2mm (1/8") drill bit. Open the door slightly for easier access, if necessary.
- Fit a 10 x 32mm screw and washer to each end. This screw should be positioned as low as possible, but make sure that it does not alter the curtain's normal approach to the guide (lead-in angle).

**NOTE:** Make sure that the screws do not project into the area where the internal gear will fit.

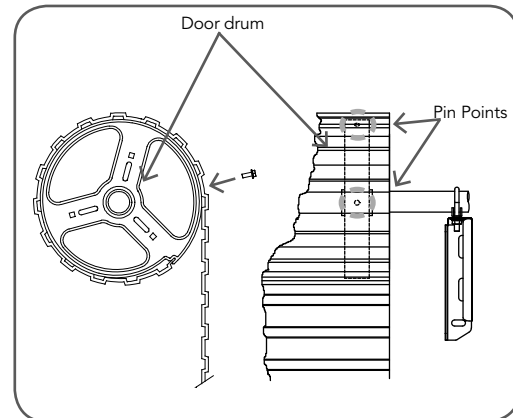

fig 07

## Step 4 - Fitting the opener

- At the end opposite to where the opener will be fitted, check that the U-bolt is tightened securely. Open the door completely and tie safety ropes around the door roll approximately 300mm from each end. Do not tie the ropes too tight as damage to the curtain may ensue.
- At the end where the opener is to be fitted, support the door with a ladder or suitable prop:



**WARNING!** Make sure the support is snug under the door, stable and will not move.

- At the end where the opener will be fitted, use masking tape or pen to mark the position of the U-bolt in the door bracket and the position of the door bracket on the wall to assist in reassembling.
- Remove the U-bolt (or bolts) and saddle from the door bracket.
- Remove the door bracket allowing the door to rest on the support (**Fig. 08**).

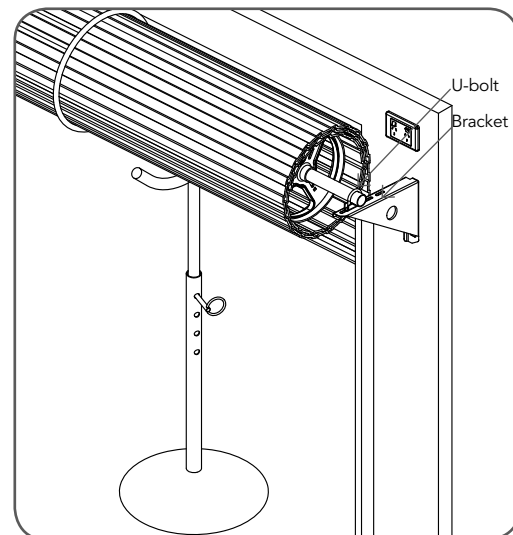

fig 08



**NOTE** - For minimum sideroom installations the door may have to be taken down.



**WARNING!** The opener must not be used with a door incorporating a wicket door.





# Installation

fig 09

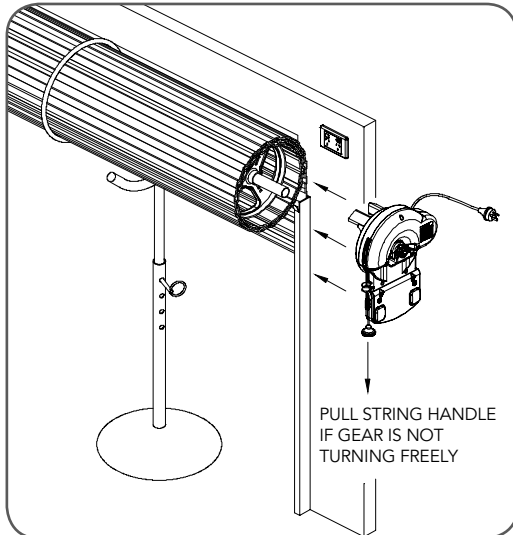
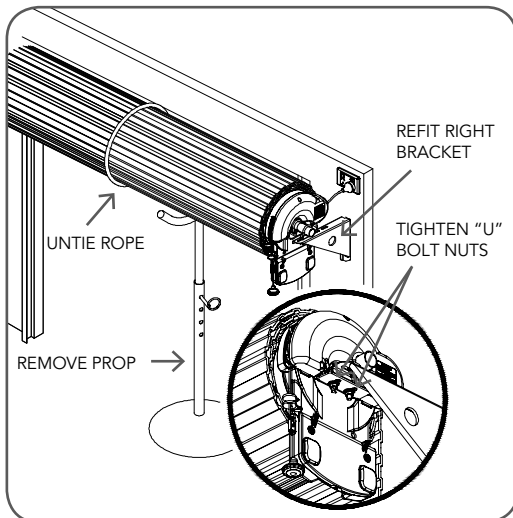

fig 10



## Step 5 - Mounting the Opener

- If the internal gear does not rotate freely, switch the opener to manual by pulling the disengagement handle down (there will be a click), so that the ring gear can be rotated by hand.
- Slide the opener over the door axle and into the drum of the door (**Fig. 09**).
- Ensure the internal gear is pushed in as far as possible (without interfering with the door curtain) and that one of the door drum's wheel spokes is completely between the opener's drive forks.
- Re-attach the door bracket using your reference marks as a guide and tighten the bolts. Ensure that the slots in the mounting bracket of the opener align with the slots in the door bracket, otherwise the door bracket may have to be relocated (**Fig. 10**).

**NOTE:** If the bracket cannot be relocated, the opener may be fitted onto the axle using the opener's saddle and U-bolt as follows:

- Using your reference marks as a guide, sit the opener on the door mounting bracket and secure with the opener's U-bolt and saddle and tighten firmly.
  - Adjust the door position (if necessary) on the brackets so that the door feeds smoothly into the guides. Make sure that the centre of the door doesn't hit the lintel and that the curtain is not pushed forward hard into the guide.
- Remove the support and safety ropes (**Fig. 10**).



**IMPORTANT NOTE** - If the manual release handle is more than 1.8 metres from floor level when the opener is installed, extend the handle to a height less than 1.8 metres.

- Connect the power cord to a suitable power point, but **DO NOT SWITCH ON**. Secure the power cord away from any moving object (e.g. the door) with the cable clip supplied.
- With the opener still disengaged, pull the door up and down to make sure it runs freely.





# Programming the Opener

## Step 6.1 - Setting Travel Limits

**NOTE:** If Safety Beams are to be used they must be installed before setting the travel limits.



**WARNING!** Use caution when operating the manual release with the door open since it may fall rapidly due to weak or broken springs, or an improperly balanced door.



**CAUTION!** Do not disengage the opener to manual operation with children, persons or any objects including motor vehicles within the doorway.

**NOTE:** To access the console, remove the controls lid cover and reattach when setup is completed.

- Move the door to halfway open. If necessary, disengage the opener by pulling the cord down (**Fig. 11**).
- Re-engage the opener by pulling the cord down.
- Turn on the power to the opener. The CLOSE LIMIT LED will be flashing.
- Press and hold the CLOSE button - the door should start closing (**Fig. 12**).
- If the door opens, release the CLOSE button and press the OPERATE button once to change the motor's direction. Press the CLOSE button again to close the door.
- Release the CLOSE button when the door is near the desired closed position. Single presses of the CLOSE button will "inch" the door closed.
- If the door overshoots, press the OPEN button to move the door in the open direction.
- When the door is at the desired close position, press the SET button to record the close limit position. The OPEN LIMIT LED will now flash.
- Press and hold the OPEN button to open the door.
- Release the OPEN button when the door is near the desired open position. Single presses of the OPEN button will "inch" the door open.
- If the door overshoots, press the CLOSE button to move the door in the close direction.



**WARNING!** Once the next step is performed, the door will automatically close and open to calculate force settings. Keep persons and objects clear of the door until it stops and the opener sounds a beep.

- Press the SET button to store the open limit. **Please read the above warning.**

## Step 6.2 - Resetting Travel Limits

To reset the limits, press and hold the CLOSE button for 6 seconds until the CLOSE LIMIT LED flashes quickly. If no action is taken within 30 seconds, the opener will return to normal operating mode and restore the original limit settings.

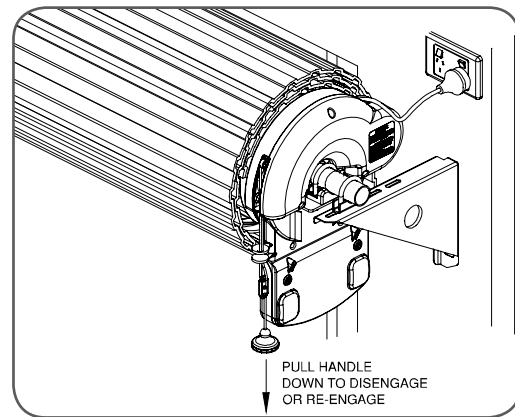

fig 11

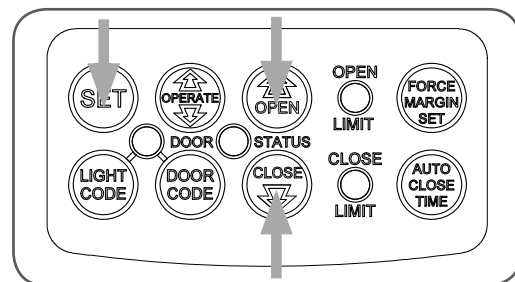

fig 12





# Programming the Opener

fig 13

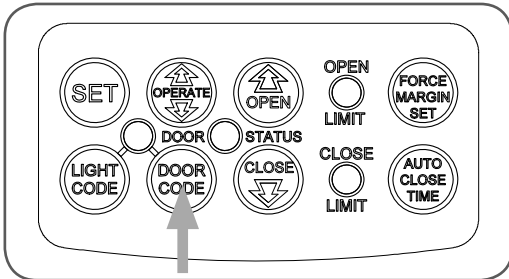
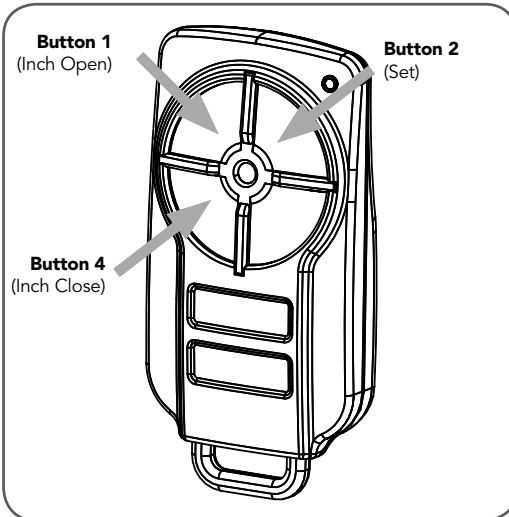

fig 14



## Setting Limits: via Transmitter

The GDO-6v4 has the alternate ability to set travel limits using the transmitter, allowing free movement around the garage to better assess the desired limit positions.

### Step 7.1 - Code a Transmitter for Limit Setting

- Ensure the opener is powered up.
- Press and hold the DOOR CODE button (Fig. 13).
- Press Button 1 on the transmitter for two seconds (Fig. 14). Release and pause for two seconds. Press the Button 1 again for two seconds.
- Release the DOOR CODE button.

### Step 7.2 - Setting Limits via Transmitter

- Press and hold Button 4 on the transmitter to close the door. When the door is approximately 2cm from the ground, press and hold Button 3 for two seconds and release (Fig. 14).
- If the door opens, release the CLOSE button and press the OPERATE button once to change the motor's direction, then repeat Step 7.2(a).
- Each press of Button 4 will allow you to "inch" the door closed. Keep doing this until the door reaches the desired close limit position.
- If the door is closed too far, press Button 1 to "inch" the door towards open.
- When happy with the close limit position, press Button 2 to store this in memory.
- Press Button 1 to open the door. When approximately 2cm from the desired open position, press and hold Button 3 for two seconds then release.
- Each press of Button 1 will allow you to "inch" the door open. Keep doing this until the door reaches the desired open limit position.
- If the door is opened too far, press Button 4 to "inch" the door towards closed.



**IMPORTANT WARNING:** The door will automatically close, open and close again **once Step 7.2(i) is performed**. Ensure that no persons or objects are in the door's path.

- When happy with the open limit position, press Button 2 on the transmitter to store into memory.
- The door will now automatically close and open to calculate the safety obstruction settings. After this, the opener can be operated with the OPERATE button.

### Step 7.3 - Resetting the Door Limit Positions

Limit positions can be deleted by the following steps:

- Press and hold the CLOSE button for six (6) seconds until you hear three beeps and the CLOSE LIMIT LED starts to flash.
- Release the CLOSE button.
- Repeat Steps 7.2 to set new travel limit positions.

**NOTE:** There is no need to re-code the transmitter (Step 7.1) upon resetting travel limits. The transmitter will still be stored in memory.





# Safety Obstruction Force



**WARNING!** Take care when testing or adjusting the Safety Obstruction Force. Excessive force may cause **SERIOUS PERSONAL INJURY** and/or **PROPERTY DAMAGE**.



**WARNING!** Safety Beams must be installed where the closing force as measured on the bottom of the door is more than 400N (40kgf)

## Safety Obstruction Force Test

### Step 8.1 - Testing Close Cycle

- Press the OPERATE button to open the door (**Fig. 15**).
- Place a piece of timber approximately 40mm high on the floor directly under the door (**Fig. 16**).
- Press the OPERATE button to close door. The door should strike the object and start to re-open.

### Step 8.2 - Testing Open Cycle

- Press the OPERATE button to close the door (**Fig. 15**).
- Press again to open the door. When the door reaches the half open point, grab the bottom rail of the door firmly and the door should stop.
- If the door does not reverse readily when closing, or stop when opening, the force may be excessive and need adjusting, refer below.



**DANGER!** If the door fails these tests, put the opener into manual mode, only operate the door by hand and call for service.

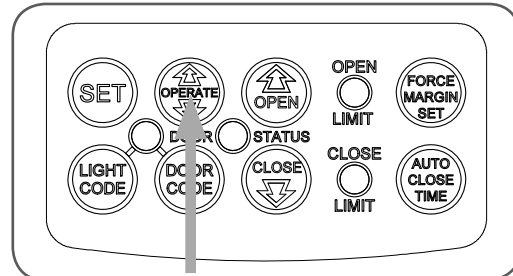

fig 15

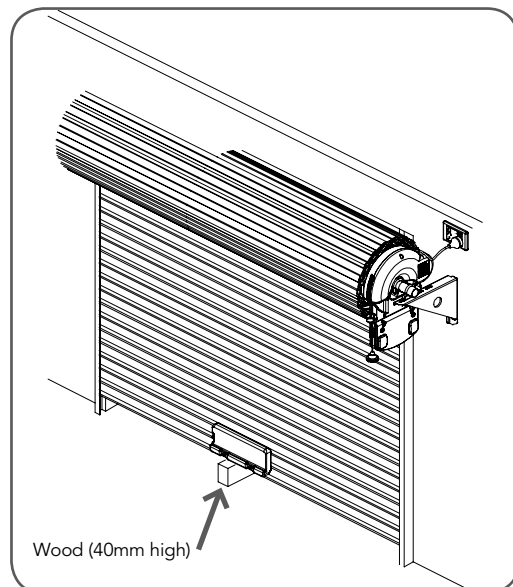

fig 16





# Safety Obstruction Force

fig 17

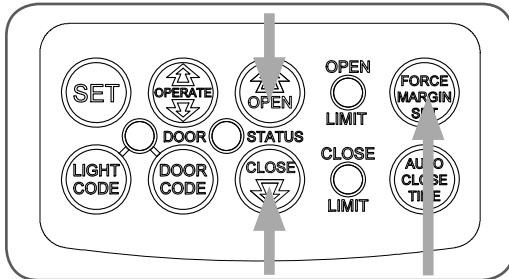

fig 18

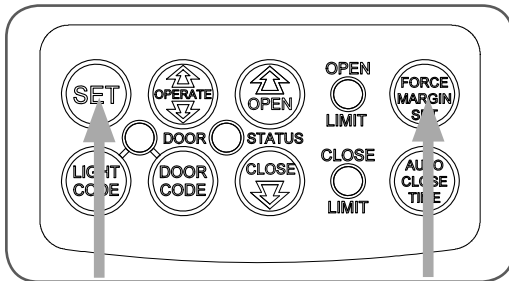
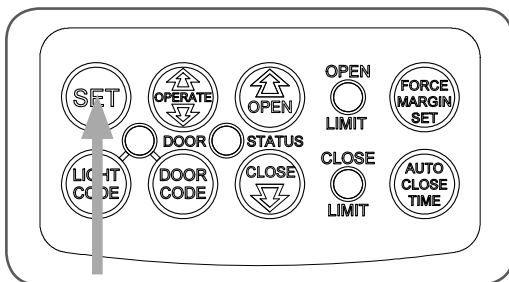

fig 19



## Adjusting Safety Obstruction Force

The Safety Obstruction Force is calculated automatically during setup. Adjusting this is normally only necessitated by environmental conditions such as windy or dusty areas, and areas with extreme temperature changes.

### Step 9.1 - To Increase Force Pressure

- Hold down the FORCE MARGIN SET button (**Fig. 17**).
- While holding the FORCE MARGIN SET button, press the OPEN button. Each press increases the force margin.
- The OPEN LIMIT LED will flash each time the OPEN button is pressed to indicate a force margin increase.

**NOTE:** If the OPEN LIMIT LED is lit continuously when pressing the OPEN button, this indicates that the maximum setting has been reached.

- Test the force again as per Steps 8.1 and 8.2

### Step 9.2 - To Decrease Force Pressure

- Hold down the FORCE MARGIN SET button (**Fig. 17**).
- While holding the FORCE MARGIN SET button, press the CLOSE button. Each press decreases the force margin.
- The CLOSE LIMIT LED will flash each time the CLOSE button is pressed to indicate a force margin decrease.

**NOTE:** If the CLOSE LIMIT LED is lit continuously when pressing the CLOSE button, this indicates that the minimum setting has been reached.

- Test the force again as per Steps 8.1 and 8.2

### Step 9.3 - To Recall Factory Set Force

- While holding down the FORCE MARGIN SET button, press the SET button for two (2) seconds. (**Fig. 18**)
- Release both buttons. The default setting should now be recalled.

### Step 9.4 - To Recalculate Force Margins

- Press and hold the SET Button for two (2) seconds, the beeper will sound once (**Fig. 19**).
- The door will start to move and re-calculate force margins. The door can move between the open and close limit positions up to four (4) times (depending on the position of the door and the power up condition).
- A single beep will be heard once the process is complete.
- Test the force again as per Steps 8.1 and 8.2.



# Coding Transmitters

## Step 10.1 - Code a Transmitter Button for Door Operation

- Press and hold the DOOR CODE button (**Fig. 20**).
- Press one of the four buttons on the transmitter for two (2) seconds, pause for two (2) seconds, then press the same button again for two (2) seconds.
- Release the DOOR CODE BUTTON.
- Press the transmitter button to test.

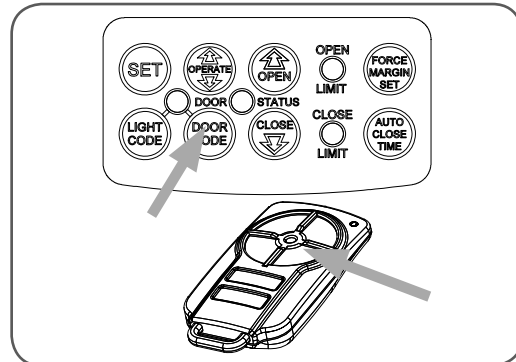

fig 20

## Step 10.2 - Coding a Transmitter Button to the Courtesy Light

The transmitter can be programmed to operate the courtesy light on the opener independently of the door moving.

- Press and hold the LIGHT CODE button (**Fig. 21**).
- Press one of the four buttons on the transmitter for two (2) seconds, pause for two (2) seconds, then press the same button again for two (2) seconds.
- Release the LIGHT CODE button.
- Press the transmitter button to test.

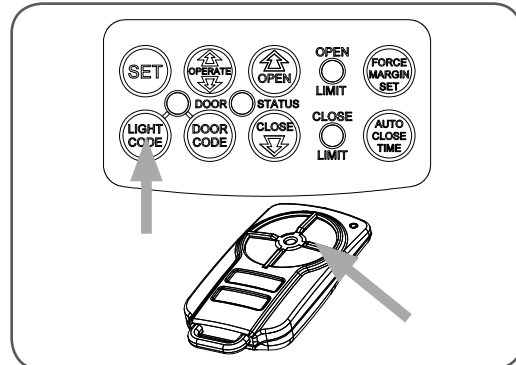

fig 21

## Step 10.3 - Code a Transmitter Button for Pet (Pedestrian) Mode

- Briefly press the DOOR CODE button three times, then press it again and hold (will beep four times on fourth press (**Fig. 22**)).
- Press one of the four buttons on the transmitter for two (2) seconds, pause for two (2) seconds, then press the same button again for two (2) seconds.
- Release the DOOR CODE button.
- Press the transmitter button to test.
- To change the default pet (pedestrian) door opening position, refer to step 17.

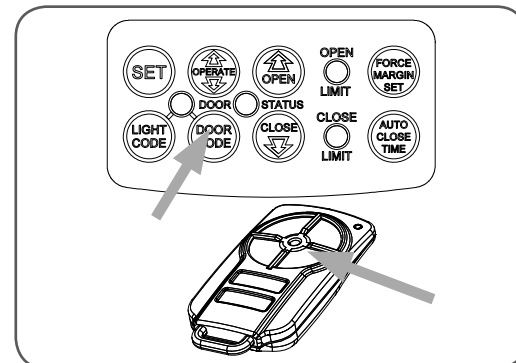

fig 22

## Step 10.4 - Code a Transmitter Button to Enable Vacation Mode

The opener can be programmed into a "Vacation Mode" where the opener will not respond to any transmitter except the button of the transmitter that was programmed for vacation mode.

- Briefly press the DOOR CODE button once, then press it again and hold (will beep two times on second press (**Fig. 23**)).
- Press one of the four (4) buttons on the transmitter for two (2) seconds, pause for two (2) seconds, then press the same button again for two (2) seconds.
- Release DOOR CODE button.
- Press and hold the transmitter button for six (6) seconds to set Vacation Mode. The door code LED will stay lit while Vacation Mode is active.
- To reset Vacation Mode, press the same button for two seconds.

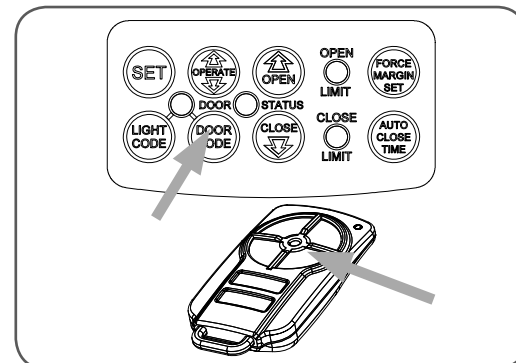

fig 23





## To use AUX to trigger another motor

# Coding Transmitters



fig 24

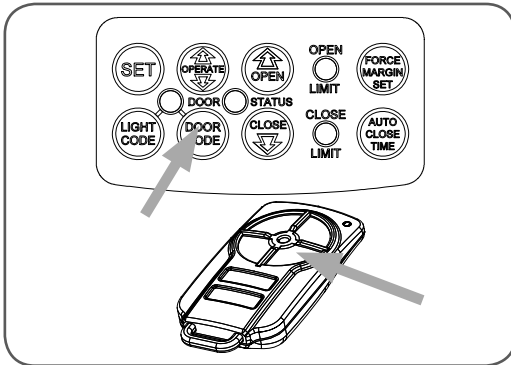

### Step 10.5 - Code a Transmitter Button to Enable AUX OUTPUT

- Briefly press the DOOR CODE button two (2) times, then press it again and hold (will beep three times on third press (**Fig. 24**)).
- Press one of the four buttons on the transmitter for two (2) seconds, pause for two (2) seconds, then press the same button again for two (2) seconds.
- Release the DOOR CODE button.
- Press the transmitter button to test.

### Step 11 - Easy Access Transmitter (EAT) Coding

- Press and hold the DOOR CODE button (**Fig. 24**).
- Press the EAT's button for two (2) seconds, pause for two (2) seconds, then press the button again for two (2) seconds (**Fig. 25**).
- Release the DOOR CODE button.
- Press the transmitter button to test.

fig 25

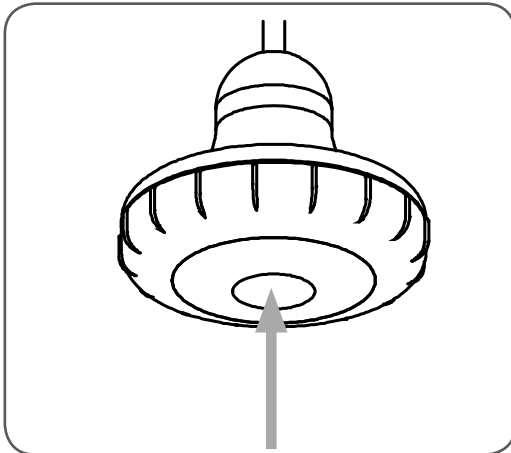

### Step 12 - Remotely Coding Transmitters

Using this method, transmitters can be coded without access to the opener's control panel as long as a pre-coded transmitter is available.



**IMPORTANT NOTE:** The door or courtesy light must activate when the steps below are performed. This indicates that the pre-coded transmitter is in range of the opener, and the correct button has been pressed.

fig 26

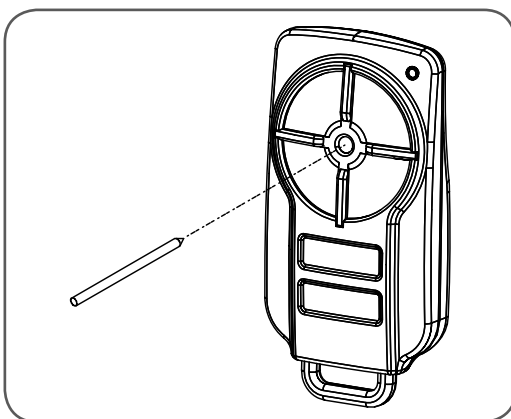

- Take any pre-coded transmitter. Press the button for the function to be duplicated and release. If the door is running, stop it by pressing the same button again.
- Using a small needle, press and hold firmly for (2) two seconds through the Coding Hole (**Fig. 26**).
- WITHIN 10 SECONDS**, take the additional transmitter you wish to code. Decide which button that you want to activate the function to be duplicated (e.g. activate the door, or turn on the courtesy light).
- Hold the new transmitter's button for two (2) seconds, pause for two (2) seconds, hold again for two (2) seconds and then release.
- Wait for 10 seconds and then press the new transmitter's button to test.





# Deleting Transmitter Codes

## Step 13.1 - Deleting a Stored Transmitter Code

- Select the transmitter you want to delete.
- Press and hold the DOOR CODE BUTTON (**Fig. 27**).
- Press the transmitter button you would like to delete for two (2) seconds, pause for two (2) seconds, press again for two (2) seconds and then release.
- Release the DOOR CODE BUTTON. The code should now be deleted. Confirm this by pressing the transmitter button - the function (e.g. door opening) should not respond.

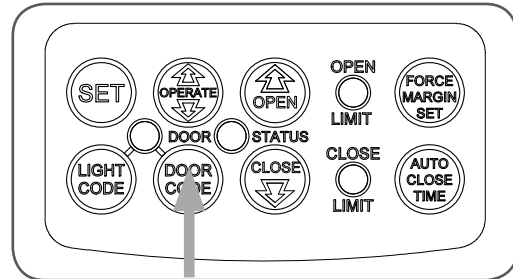

fig 27

## Step 13.2 - Deleting All Transmitter Codes

- Turn off power to the opener.
- While switched off, press and hold the DOOR CODE BUTTON (**Fig. 27**). Turn on the power to the opener while holding this button.
- The OPEN LIMIT, CLOSE LIMIT and DOOR STATUS LED's will illuminate for about five (5) seconds. These LED's will turn off and the CODING LED will illuminate.
- Release the DOOR CODE BUTTON. All stored codes will now be deleted. Confirm this by pressing buttons on any previously coded transmitters - the opener should not respond.





# Wired Safety Beams Installation

fig 28

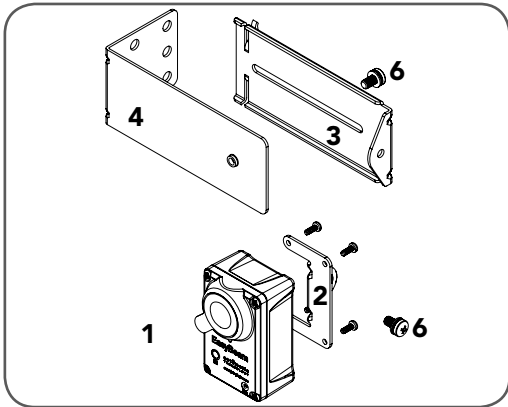

## Step 14 - Safety Beams (optional)

Safety Beams extend across the garage door opening. The Safety Beam is designed to detect an obstruction while the door is closing and to send a signal to the garage door opener to reverse or stop the door movement. One or two sets of Safety Beams can be connected to GDO-6v4 EasyRoller® opener.

### Step 14.1 - Fitting the Safety Beam

- Attach the mounting bracket (4) to the adjustment bracket (3) with the pan head screw (6) (supplied). (Fig. 39)
- Attach the bracket (2) to the Safety Beam transmitter with four taptite screws (m3x5) and attach the other side to the adjustment bracket (3) with the pan head screw (6) . (Fig. 28)
- Repeat steps a and b to assemble the Safety Beam receiver.

fig 29

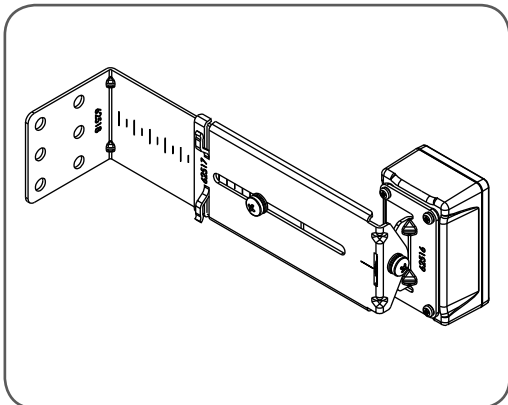

- Mount the receiver to one side of the door and transmitter on the other side in line with receiver. The mounting surface should be rigid. ATA recommends the transmitter and receiver are placed in line of sight, with the beam 100mm above ground level (as per AS60335). They should also be placed as close as possible to the door opening. Connect as per the wiring diagram (Fig. 30).

### Step 14.2 - Alignment

- Power up the opener with the Safety Beam connected. The green LED on the transmitter should turn ON to indicate power is present.
- If the receiver is connected to power and the red LED is flashing while the green LED on the transmitter is on, the transmitter and receiver are not aligned.
- Make horizontal and/or vertical adjustment on the transmitter and/or receiver until the red LED on the receiver turns on, indicating alignment.

fig 30

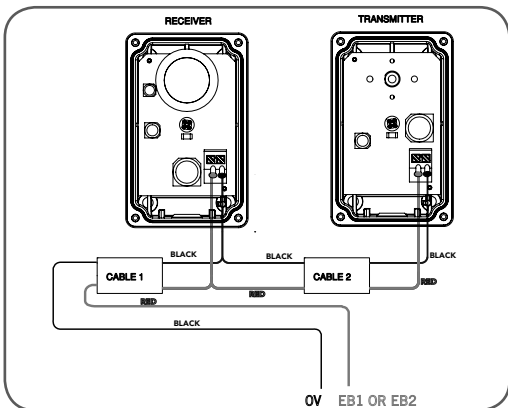

**NOTE:** The sensors need to be 100mm above the floor level, however, the exact position must be chosen in such a manner that it suits the application, the environmental conditions and provides maximum safety protection.



**WARNING:** Safety Beam must be installed if the closing force as measured at the bottom edge of the door exceeds 400N (40kg).

**NOTE:** Three wire Safety Beam is not compatible with GDO-6v4 EasyRoller® opener.

**GDO-6v4 EasyRoller® is compatible with wireless safety beams. Please refer to instructions provided with wireless safety beams for installation details.**





# Wired Safety Beams Installation

## Step 19.2 - Safety Beam Failure Emergency Close

When the user finds that they are unable to move the door and suspect that it is due to a faulty SAFETY BEAM they can attempt to enter Safety Beam Failure Emergency Close mode by press and holding a pre-coded button on the remote control or OSC button on the console for five seconds.

## Auto-Close

### Step 15 - Setting Up Auto-Close Mode



**IMPORTANT NOTICE:** It is compulsory to have Safety Beams installed when using Auto-Close mode.

Auto-Close mode is a function that automatically closes the door a preset time after the Safety Beams recognise that a vehicle has left the garage.

The Auto-Close timer only starts after the Safety Beam's path is broken. If the safety beam path is not broken, the door will remain open until the path is broken. If the opener incurs a physical obstruction (i.e. not from the Safety Beams) while closing the door, it will re-open and not Auto-Close until the Safety Beam's path is broken again.

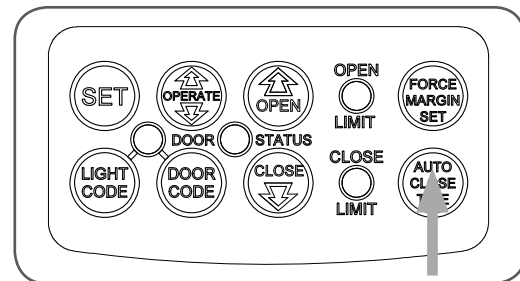

### Step 15.1 - Setting Auto-Close Time

- Hold down the AUTO CLOSE TIME button (**Fig. 31**).
- While holding in the AUTO CLOSE TIME button, press the OPEN button - each press will add one second to the Auto-Close delay.
- To decrease the delay time follow Step 15.1(a) and press the CLOSE button - each press will deduct one second from the Auto-Close delay.
- Press the OPERATE button or transmitter to open the door. When the door is fully opened the OPEN LIMIT LED will flash to indicate that Auto-Close mode is operational.
- Break the Safety Beam's path momentarily to initialise Auto-Close. When the door reaches the fully opened position, the door will pause for the set Auto-Close time and then close.





# Final Setup

fig 32

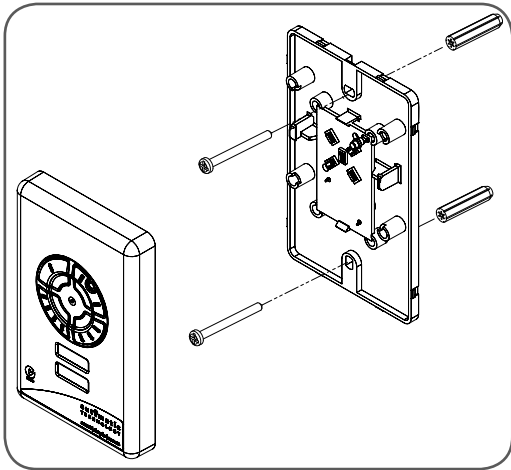
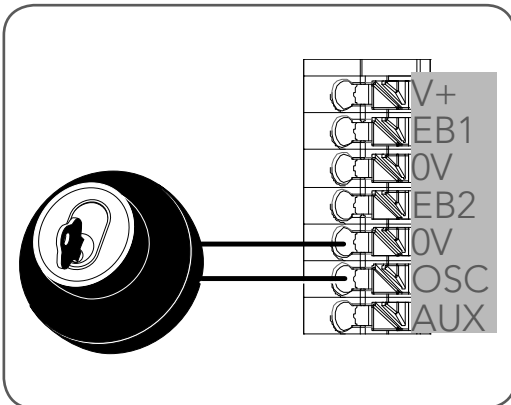

fig 33



## Step 16 - Setting of Courtesy Light Time

The preset courtesy light time is three minutes. This time can only be changed by a "PG3" programmer.

## Step 17 - Setting the Pet Mode position

The default Pet Mode height can be changed as follows:

- Drive and stop the door at the desired Pet Mode open position by pressing O/S/C button on the console or the transmitter button coded for O/S/C operation.
- Press and hold the OPEN button for six (6) seconds until the OPEN and CLOSE LED's are lit to record the new pet position.

When activated, Pet Mode drives the door to the preset position from the close position. Pet Mode's active status is indicated by both the OPEN and CLOSE LIMIT LED's being illuminated. If a Pet Mode button is pressed while the door is moving, the door will stop. If a Pet Mode button is pressed when the door is in the Pet position, then the door will close.

## Step 18 - Installing the Wall Mounted Transmitter (Optional)

- Remove the faceplate from the transmitter.
- Affix the baseplate in a convenient wall location (**Fig 32**) where the door is visible but out of the reach of children at a height of at least 1.8 metres from the floor.
- Replace the faceplate.
- To code the transmitter, see Steps 10.1 through 10.4 on page 19.

## Step 19 - Keyswitch Connection

The GDO-6v4 has the input to connect bell switch or keyswitch to open or close the door. Connect the key/bell switch as per diagram (**Fig. 33**).





# Final Setup

The motor must be able to be triggered by Milliamp to conect this way otherwise you have to use a relay

## Step 20 - Auxiliary Output

The auxiliary output can be used to control alarm or another garage door opener. A valid transmission from the pre-coded transmitter will cause the auxiliary output to pulse for approximately 1 (one) second. The maximum DC voltage must not exceed 35 volts DC. Maximum current must not exceed 80 ma. (Fig. 34).

## Step 21 - Reset all Factory Defaults

- Turn power to the opener off.
- Press and hold the SET Button (Fig 35).
- Turn power on while holding the SET button. Continue to hold until all LED's are off.
- This will not erase transmitter codes stored in memory.

If you are using a relay then the wires go AUX OUT and PWR to operate the Relay Then on the Relay the common and Normally open pins get connected to the other motor

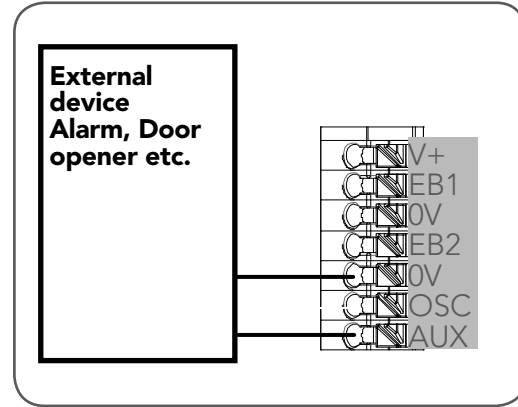

fig 34

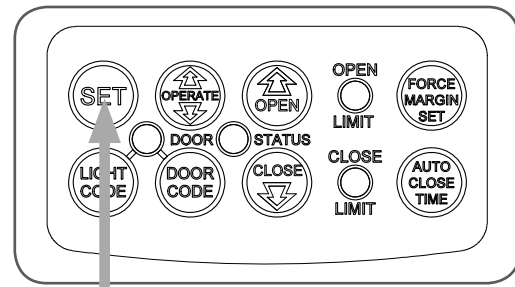

fig 35





# SmartSolar™ Installation

Fig 36

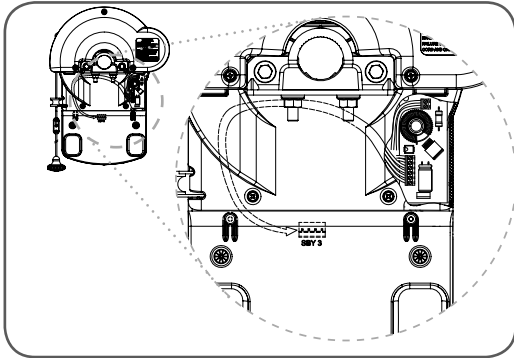

**WARNING:** Do not connect the batteries until after Step 22.2.

## Step 22.1 - Mount the Charger Board

1. Unplug the drive unit from mains power.
2. Disengage motor using manual release cord.
3. Remove the main cover, timing cover and light diffuser. Then remove the transformer and mains power cable.
4. Fix the Charger Board under the timing cover using four (4) M4x8 screws (Fig. 36).
5. Feed the three wire cable through the opening, then connect the three wire harness (red/yellow/black) into the control board's "SBCO-2" connector (Fig. 37).
6. Plug the solar shunt (supplied) onto the control board's "JP1" connector marked "solar" (Fig. 37).

Fig 37

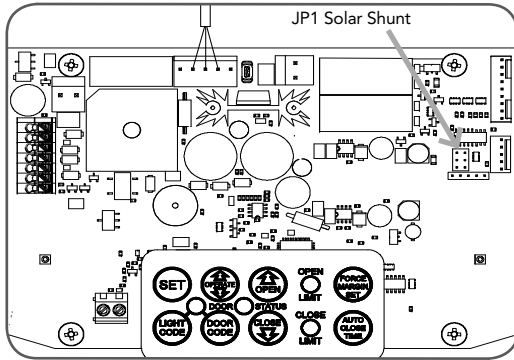

**IMPORTANT WARNING:** Do not connect battery or solar panel polarity incorrectly - this will result in serious damage to components.

## Step 22.2 - Connect the Solar Panel

1. Mount the solar panel as described in the SmartSolar™ Instruction Manual.
2. Feed the Solar Panel's cable through the black grommet on the chassis.
3. Connect the **red wire** to the Charger Board's "SOLAR+" connector, and the **black wire** to the "-SOLAR" connector (Fig. 38).

Fig 38

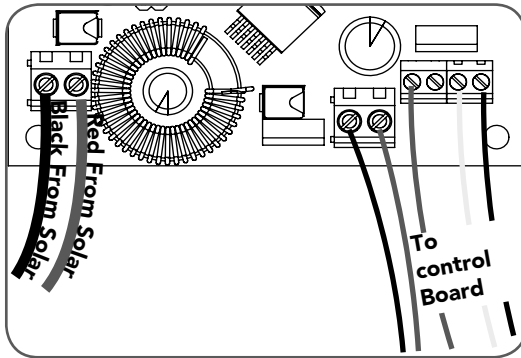

**WARNING:** During Step 22.3 the opener will become active.

## Step 22.3 - Mount & Connect the Battery

1. Mount the Battery Box close to the opener.
2. Feed the 2-core 18awg gauge cable (supplied) through the Battery Box's grommet.
3. Connect the **red wire** to the Battery Box's "+" terminal, and the **black wire** to the "-" terminal (Fig. 39).
4. Feed the other end of the battery cable through the drive unit's black grommet.
5. Connect the **red wire** to the Charger Board's "BAT+" connector, and the **black wire** to the "-BAT" connector (Fig. 39).
6. Refit the timing cover, main cover and light diffuser.

Fig 39

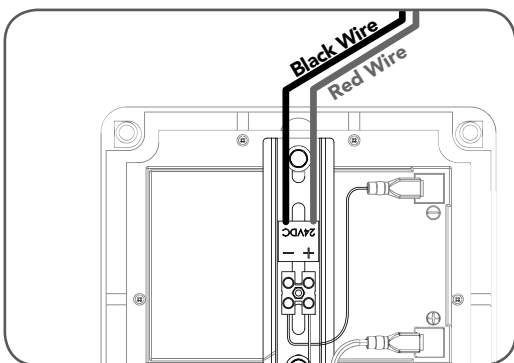

## Step 22.4 - Re-setup and Test the Opener

1. Setup travel limits and code transmitters as per the GDO-6v4 instruction manual.
2. Press either the OPERATE button, or use a transmitter to operate the opener.





# Battery Backup Kit Installation

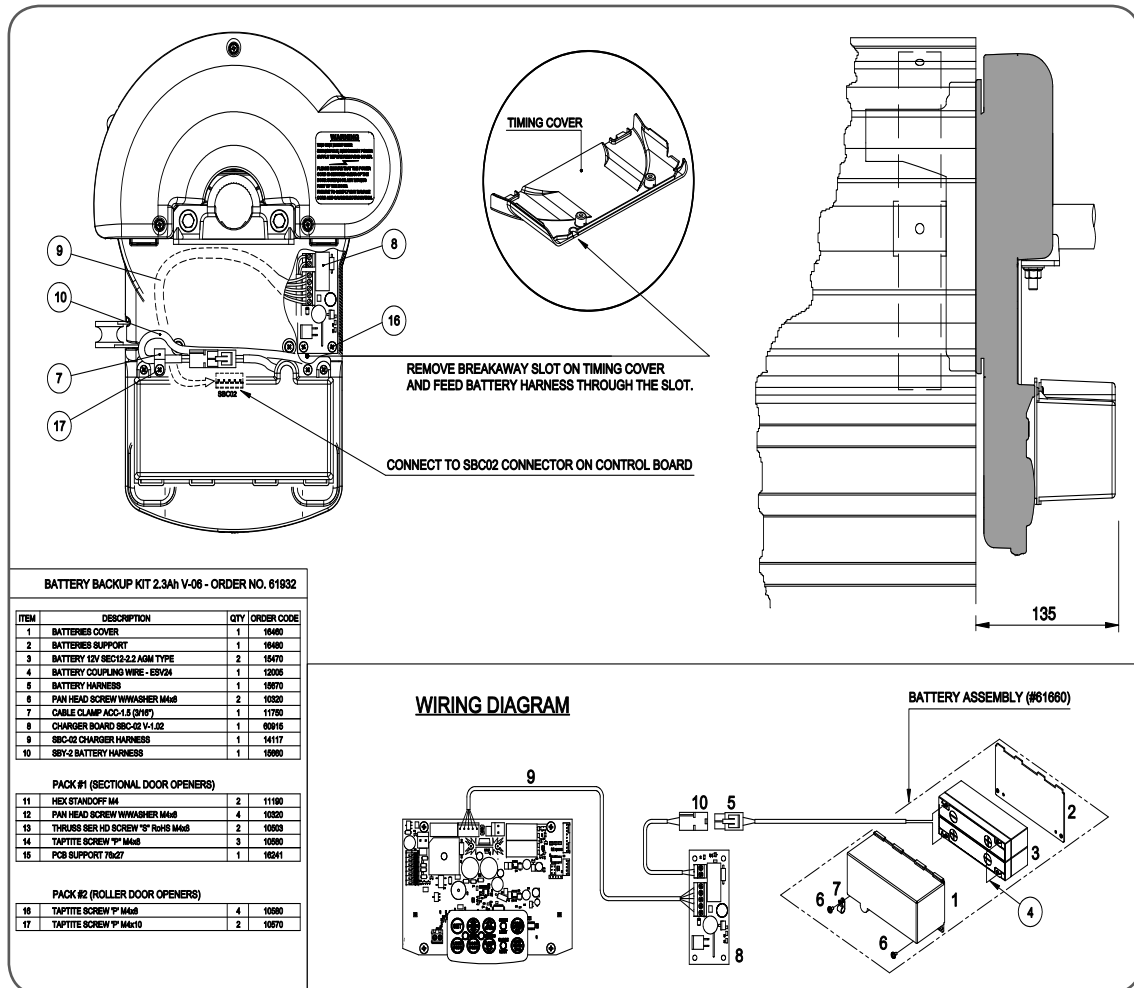

Fig 40

## Step 23.1 - Connect the Battery Backup Kit

- Turn off power to the opener and disengage motor.
- Remove timing cover and light diffuser.
- Remove cable clamp and screw (Fig. 40). Retain cable clamp for later use.
- Mount the SBCO-2 Charger Board on base and secure with four (4) Taptite 'P' M4 x 8 screws.
- Secure lower left corner with cable clamp holding brown transformer wires.
- Feed five-wire harness around timing assembly, through opening and plug into control board's SBCO-2 connector (Fig. 40).
- Remove break away slot on timing cover.
- Feed 2-wire battery harness item 5 through slot and replace timing cover and secure in place with screws.
- Mount Battery Backup Kit onto support chassis and secure right side screw first (charger board side).
- Position 2-wire battery harness neatly and secure left side of battery kit with cable clamp.



**WARNING:** After Step 23.1(k) the opener may become active (even when power is off). This is a result of a residual charge in the batteries.

- Connect battery harness together (Fig. 40).
- Reconnect power and re-engage the motor.

## Step 23.2 - Testing the Battery Backup Kit.

- Press either the OPERATE button or transmitter button to activate the door.
- Whilst the door is in motion disconnect mains power. When mains power is cut, the Battery Backup Kit should respond to the shut down. The door should continue operating as normal.



**NOTE:** Wait for the door to complete its travel.

- Press OPERATE or a transmitter button to activate the door.
- Whilst door is in motion, re-connect power. The door should complete the cycle as normal. Unplug the drive unit from mains power.





# Parameters

## Door Status Indicators

Door Opener State	OPEN LED (Green)	CLOSE LED (Red)	STATUS LED (Yellow)	Beeper
Open	On			
Close		On		
Opening	Flashing			
Closing		Flashing		
Door travel stopped	Flashing	Flashing		
Door obstructed when opening	Flashing			
Door obstructed when closing		Flashing		Beeps as door moves
Opener overloaded	Alternating flashes	Alternating flashes		
Door in open position with Auto-Close mode selected	One second flashes			
Pet Mode engaged	On	On		
Mains power interrupted	Rapid flashes			
Service due			On	3 Beeps At The Start Of Each Cycle





# Parameters

## Button Functions

Buttons	Function
OPERATE	Opens/Stops/Closes the door pressing & holding will close the door in the event of safety beam is not functioning
DOOR CODE	Codes a transmitter button for operate, vacation, auxiliary and pet functions
LIGHT CODE	Codes a transmitter button for light function
FORCE MARGIN SET & OPEN	Increases the obstruction force margin setting
FORCE MARGIN SET & CLOSE	Decreases the obstruction force margin setting
FORCE MARGIN SET (then) SET	Resets the factory default force margin settings
AUTO CLOSE TIME (then) OPEN	Increases the Auto-Close delay time
AUTO CLOSE TIME (then) CLOSE	Decreases the Auto-Close delay time
AUTO CLOSE TIME (then) SET	Resets the factory default Auto-Close delay time
CLOSE (for 6 secs.)	Clears the door limits set positions. Limits then need to be reset
SET (then power on) & hold until all LED's are off	Deletes control parameters excluding transmitter storage memory
DOOR CODE (then power on) & hold until all LED's are off	Deletes all transmitter storage memory
SET & DOOR CODE (the power on) and hold until all LED's are off	Deletes all control parameters and transmitter storage memory.
SET	Re-initialises the Opener to re-calculate force margin





# Default Settings & Specifications

## Factory Default Settings

	Default	Step	Maximum
Maximum motor run time	25 secs	-	-
Courtesy light time	3 mins	10 secs	4 mins
Obstruction force margin	7	1	20
Auto close time	0 secs	1 secs	4 mins
Maintenance counter	3000		

## Technical Specifications

Power supply	230V - 240V A.C. 50Hz
Standby power	2.2 Watts
Input power	230 Watts
Motor power	100 Watts
Motor type	24VD.C. Permanent Magnet
Rated operating time	4 mins
Rated temperature	+5°C to 40°C
Rated force	500N
Controller Voltage	24VD.C.
Maximum door opening: Width: Height: Weight:	5500mm 3000mm 100kg
Opener Limits Travel	3.0 turns of Door Drum Wheel
Receiver type	TrioCode™ type
Receiver code storage capacity	64 X 4 button Transmitter Codes
Transmitter frequency	TrioCode™ type
Coding type	Code hopping
Number of code combinations	Over 4.29 billion random codes
Code generation	Non-linear encryption algorithm
Courtesy light	Bright LED
Controller fuse	10A slow blow

### NOTE:

1. The door must be well balanced. A person should be able to lift the door up manually with very little effort in case of an emergency.
2. Intermittent operations may occur in areas which experience very strong winds. Strong wind puts extra pressure on the door and tracks which may in turn trigger the safety obstruction detection system intermittently.





# Troubleshooting

Symptom	Possible cause	Remedy
Door will not operate	Mains power not switched on.	Switch on mains power.
	Door is obstructed.	Remove obstruction.
	Door is locked or motor jammed.	Unlock door or remove jam.
	Door tracks/hardware damaged.	Door requires service/repair by qualified technician.
	The opener is in "vacation mode".	Turn off "vacation mode".
Door starts to close but automatically reverses to open position	Adverse weather conditions (wind or cold) causing door to stiffen and become tight in the tracks.	Increase force margin setting. See page 18 to re-calculate force margin.
	Possible obstruction in the doorway.	Remove obstruction.
Door operates from drive unit (OPERATE) button but not from transmitter*  See note	Transmitter code not stored in memory.	Code transmitter in to openers memory. Refer step 10.1 on page 19
	Flat battery.	Replace battery
	Broken battery lead inside transmitter.	Send transmitter to installer or Automatic Technology for repair.
Door will not close fully.	Door limits positions need to be reset.	Reset limits positions. Step 7.3, page 16.
Door will not open fully.	Door limits positions need to be reset.	Reset limits positions. Step 7.3, page 16.
Auto-Close not working	Safety Beam or wiring faulty.	Repair Safety Beam or replace wiring.
	Safety Beam not aligned correctly.	Re-align optics.
	Safety Beam is obstructed.	Remove obstruction from path of Safety Beam.
	Door obstructed when closing.	Remove obstruction.
	Auto-Close time not set.	See Step 15 on page 23.
Opener beeps and flashes at the end of each operation	Service is due on the door and opener	Please refer to page 30 or sticker on the back of the door for more information

**PLEASE NOTE:**

\*Some areas may be prone to excessive radio interference brought on by devices such as cordless telephones, wireless stereo headphones and baby monitors. It is possible that these devices could cause a degree of interference such as to greatly reduce the range of the transmitter. In such an instance, please contact your Automatic Technology dealer for an alternative frequency replacement kit. As this is not a warrantable situation but an environmental issue, charges may apply for the change over.

**Safety Beams** must be installed if the closing force at the bottom edge of the door exceeds 400N (40 kg) force





# Maintenance

## Maintenance

Whilst your opener does not require any periodic maintenance, the door that it is fitted to, does. Your garage door is a large, heavy, moving object and should be tested regularly to ensure it is in good condition. A poorly maintained door could cause fatal or serious injuries or serious damage to property.

To ensure a long and trouble free life for your opener the following is recommended:

## Monthly

- Disengage the opener and manually operate the door: The door must be smooth to operate by hand. An operating force on the bottom rail should not exceed 150N (15kg) force.
- Each month check that the opener reverses when the door contacts a 40mm high object placed on the floor (AS3350).

**NOTE:** If the door does not operate smoothly, call your door professional.

## Maintenance counter

GDO-6v4 EasyRoller® has a built in maintenance counter. From factory this is loaded with 3000 cycles. When this counter expires, the service yellow LED will light up. At the start of each door movement the beeper will sound three times. After opening or closing the door the courtesy light will flash and beeper sound five times.

At this time Automatic Technology recommends you contact your door professional to perform an annual door service.

When maintenance counter is active it can be reloaded with 3000 cycles by press and holding the SET button on the console.



**CAUTION:** Frequently examine door, particularly cables, springs and mountings for signs of wear, damage or imbalance. Do not use if repair or adjustment is needed since a fault in the installation or an incorrectly balanced door may cause injury. (AS3350)



Adjustments should only be carried out by experienced persons, as this function can be dangerous if not performed under strict safety procedures.



**WARNING!** Failure to maintain your garage door may void the warranty on your garage door opener.

## Service Record

Record any maintenance in the following table to assist in any warranty service.

Date	Service by	Signature	Invoice No.	Amount



# Spare Parts

ITEM NO.	DESCRIPTION	ORDER CODE
1	DRIVE CHASSIS	63011
2	CLUTCH GEARED MOTOR ASSY 12-02	60373
3	HEX SERRATION HEAD SCREW M6x16	10170
4	TRANSFORMER TDB-100-143 V2 KIT	62022
5	CORD GRIP GROMMET SB5P-2	65606
6	POWER CORD 1.5M W2P+1R	14150
7	TERMINAL BLOCK 1500/13DS	61443
8	CAP POLYFILM 0.1UF KX2 275VAC	67575
9	PAN HEAD SCREW W/WASHER M4x25	10344
10	WIRE EARTH ASSY 230L	12150
11	PAN HEAD SCREW W/WASHER M4x8	10320
12	MOUNTING BRACKET VR1	62504
13	HEX SERRATION HEAD SCREW M8x16	10122
14	SUPPORT CHASSIS	16205
15	GROMMET 101422	65603
16	TIMING ASSY	61732
17	TIMING HARNESS ASSY	61791
18	STRING GUIDE	16420
19	GDO-6V4 C.B. DCB08-1.02-620J	20303
20	DUST COVER BOTTOM	63222
21	DUST COVER TOP	63223
22	TAPTITE SCREW 'P' M4x10	10570
23	TAPTITE SCREW 'P' M4x6	10582
24	INTERNAL GEAR	16020
25	CLAMP WASHER	11180
26	RETAINING RING STW 45	10650
27	EASY ACCESS TRANSMITTER PACK (EAT-2)	61242
28	LITHIUM BATTERY 3V	13020
29	MAIN COVER ORANGE AY	16249
30	TIMING COVER	63225
31	LIGHT DIFFUSER ASSY GDO-6V4	65121
32	CONTROLS LID COVER	65103
33	INDUSTRIAL SADDLE	63175
34	U-BOLT M8	10141
35	HEX SERRATION FLANGE NUT M8 (BLACK)	10148
36	FLAT WASHER 8.4x18x1.6	11021
37	TAPTITE SCREW 'P' M4x8	10580
38	PAN SERRATION HEAD SCREW M4x12	10340

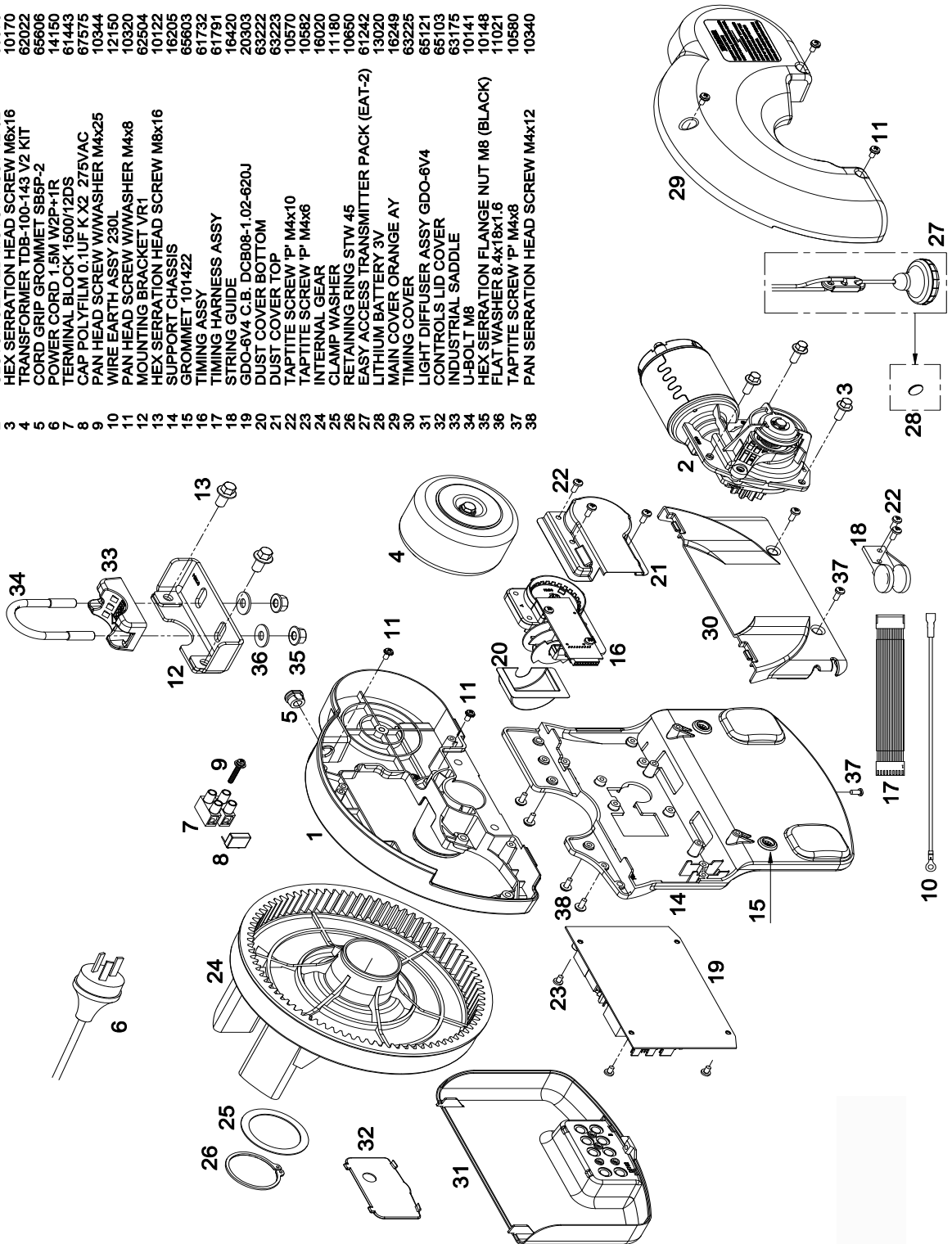



# Important Safety Checks

Please refer to the risk assessment table below and ensure all the necessary controls are in place.

## Installation Risk Assessment

Hazard	Control
Muscular strain from incorrect lifting of opener	<ul style="list-style-type: none"><li>Practice correct lifting techniques (carton weighs 9 kg)</li></ul>
Muscular strain from incorrect lifting of door	<ul style="list-style-type: none"><li>Practice correct lifting techniques when required to lift the door as per installation instructions</li></ul>
Entanglement in operating Opener	<ul style="list-style-type: none"><li>Never plug in and operate prior to installation</li></ul>
Uncontrolled spring tension release	<ul style="list-style-type: none"><li>Follow the installation instructions</li><li>Ensure the U-bolt on the opposite end to the motor is tight</li><li>Do not conduct any door repairs or maintenance (contact professional for all door servicing)</li></ul>
Fall from ladder	<ul style="list-style-type: none"><li>Ensure ladder is the correct type for job</li><li>Ensure ladder is on flat ground</li><li>Ensure user has 3 points of contact while on ladder</li></ul>
Crush injury from unsecured door	<ul style="list-style-type: none"><li>Place a 2 metre exclusion zone around area under the door while it is unsecured</li><li>Do not move under door while on door support (or ladder)</li><li>Follow the installation instructions</li><li>Fit door support (or ladder) snugly under door before removing U-bolt and bracket</li><li>Ensure door support (or ladder) is on flat ground</li></ul>

## Testing and Operation Risk Assessment

Hazard	Control
Entrapment under operating door	<ul style="list-style-type: none"><li>Keep children clear of operating door</li><li>Ensure the garage door is in good working order</li><li>Correctly set the Safety Obstruction Force</li><li>Install Photo Electric Beams (recommended)</li><li>Do not operate door when persons are near the door</li></ul>
Entanglement in moving door	<ul style="list-style-type: none"><li>Fit locking bar covers</li><li>Keep hands and loose clothing clear of door and guides at all times</li></ul>
Entanglement in operating Opener	<ul style="list-style-type: none"><li>Never plug in and operate prior to installation</li></ul>
Electrocution	<ul style="list-style-type: none"><li>Place opener in protected area so that it does not get wet</li><li>Do not spray with water</li><li>Do not open the protective covers</li><li>Do not operate opener if cable is damaged</li></ul>



# Warranty and Exclusion of Liability

1. This Warranty is given by Automatic Technology (Australia) Pty Ltd (ABN 11 007 125 368) (ATA), 6-8 Fiveways Boulevard, Keysborough 3173, 1300 133 944, sales@ata-aust.com.au
2. The Competition and Consumer Act 2010 (including the Australian Consumer Law) and other relevant statutes provide a set of statutory consumer guarantees and other legal rights that cannot be excluded, restricted or modified by contract. This Warranty is in addition to and does not affect any of your rights under the Australian Consumer Law and other relevant statutes.
3. Our goods come with guarantees that cannot be excluded under the Australian Consumer Law. You are entitled to a replacement or refund for a major failure and for compensation of any other reasonably foreseeable loss or damage. You are also entitled to have the goods repaired or replaced if the goods fail to be of acceptable quality and the failure does not amount to a major failure.
4. Subject to your non-excludable rights under the Australian Consumer Law, ATA expressly excludes any liability for consequential loss, incidental or indirect damages (including but not limited to damages for loss of business profits, business interruption and loss of business information) due to a defect of the GDO-6v4 EasyRoller® (Product). In particular any loss or damage caused to other equipment or accessories used with the product or any loss resulting from a delay in repair is excluded to extent permitted by law.
5. Subject to all of the matters set out below, ATA warrants in relation to the Product that:
  - (a) the Product's drive units will be free of any defects in material and workmanship for at least 24 months after the date of purchase (as evidenced by the sales docket receipt), or 5000 cycles, whichever ever occurs first; and
  - (b) the Product's other components and accessories will be free of any defects in material and workmanship for at least 12 months after the date of purchase (as evidenced by the sales docket receipt).
6. No additional warranty will apply for Products repaired during the relevant warranty period.
7. For all Products repaired outside the warranty period, a six (6) month warranty that the Product will be free of any defects in material and workmanship will apply from the date of dispatch of the Product to you. ATA may charge you for any repairs undertaken outside the warranty period, and will provide you with a quotation in relation to any such costs for your approval before proceeding with any repairs.
8. This Warranty applies only where you:
  - (a) immediately notify ATA at the contact details provided in paragraph 1 above or notify the or the retailer that you purchased the Product from of the alleged defect;
  - (b) return the product to the retailer that you purchased the Product from; and
  - (c) present the relevant sales docket and this Warranty document to the retailer to confirm the date of purchase.
9. Except for this Warranty, ATA gives no warranties of any kind whatsoever (whether express or implied), in relation to the product, and, subject to paragraph 1 above, all warranties of whatsoever kind relating to the product are hereby excluded.
10. This Warranty excludes damage resulting from:
  - (a) normal wear and tear;
  - (b) accidental damage;
  - (c) incorrect installation of the Product;
  - (d) blown fuses, electrical surges, power surges or power spikes;
  - (e) theft, fire, flood, rain, water, lightning, storms or any other acts of God;
  - (f) any installation, configuration or use of the Product contrary to the instructions supplied with the Product;
  - (g) maximum continuous operating time exceeding 1 minute in 10;
  - (h) the operating force exceeding 15kg\* (150 Newton) when moving the door manually to the open or closed position;
  - (i) the door surface area exceeding 16.5m<sup>2</sup>;
  - (j) the door used with the Product not being in safe working order and condition;
  - (k) repairs which are not authorised by ATA;
  - (l) any failure to install or maintain the Product in accordance with the instructions supplied with the Product;
  - (m) any use which is not in accordance with the instructions provided with the Product;
  - (n) deliberate or negligent damage to the Product;
  - (o) any unauthorised modification to the Product;
  - (p) faulty or unsuitable wiring in the building in which the Product is installed;
  - (q) damage caused by insects;
  - (r) any cost or expense relating to the recall of the Product;
  - (s) installation of a residential garage door opener in a commercial or industrial premises or in a dwelling other than a single-family dwelling;
  - (t) radio or electrical interference; or
  - (u) acts or omissions of any person (including service providers approved by ATA) other than ATA.
11. ATA's liability under this Warranty is limited, at ATA's absolute option, to replacing or repairing the product which ATA, in its unfettered opinion, considers to be defective either in material and/or workmanship or to credit the dealer with the price at which the product was purchased by the dealer.
12. This Warranty does not extend to cover labour for installation of the Product following repairs, the cost of which must be borne by you.
13. This Warranty is limited to Return-to-Base (RTB) repair and does not cover labour for on-site attendance, the cost of which must be borne by you.
14. Except as specified in this Warranty, ATA will not charge you for any repairs or replacements conducted under the Warranty. However, ATA will charge you for any repairs which are not within the scope of this Warranty (or which are not required to be undertaken free of charge pursuant to the Australian Consumer Law).
15. This Warranty is void if the Product is not returned to the manufacturer in original or suitably secure packaging.
16. This Warranty is only applicable for repairs to the product carried out within Australia.
17. This Warranty does not cover consumable items including, without limitation, globes, batteries and fuses.
18. This Warranty is not transferable.
19. Where the Product is retailed by any person other than ATA, except for the warranty set out above, such person has no authority from ATA to give any warranty or guarantee on ATA's behalf in addition to the warranty set out above.
20. Any provision of this Warranty that is prohibited or unenforceable in any jurisdiction is ineffective as to that jurisdiction to the extent of the prohibition or unenforceability. That does not invalidate the remaining provisions of this Warranty nor affect the validity or enforceability of that provision in any other jurisdiction.
21. Products presented for repair may be replaced by refurbished goods of the same type rather than being repaired. Refurbished parts may be used to repair the Product.

## NOTES:

1. One (1) cycle = one (1) open and one (1) close action of the door.
2. This Warranty is to be read in conjunction with the owner's copy of the installation instruction manual.
3. \* The door that the Product is used with should be balanced in such a way that the user is able to open or close the door manually using a force not greater than 150 Newton (15 kg), other than to initially cause the door to start moving, which may require force in excess of that specified in this paragraph.





© July 2012 Automatic Technology (Australia) Pty Ltd. All rights reserved. TrioCode™, SmartSolar™ are trademarks and EasyRoller® is a registered trademark of Automatic Technology (Australia) Pty Ltd. No part of this document may be reproduced without prior permission. In an ongoing commitment to product quality we reserve the right to change specification without notice. E&OE.

automatic  
TECHNOLOGY

smart | simple | secure

an alesco company

**Automatic Technology (Australia) Pty Ltd**

ABN 11 007 125 368

6-8 Fiveways Boulevard  
Keysborough, Victoria, 3173, Australia

P 1300 133 944

+61 2 9722 5666 (International Enquiries Only)

E sales@ata-aust.com.au

www.automatictechnology.com.au